

the Dosing Funnel™ 54

BEA201



Breville



54mm

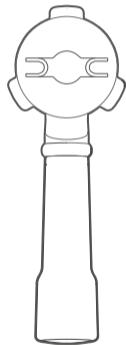

58mm

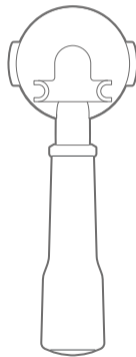

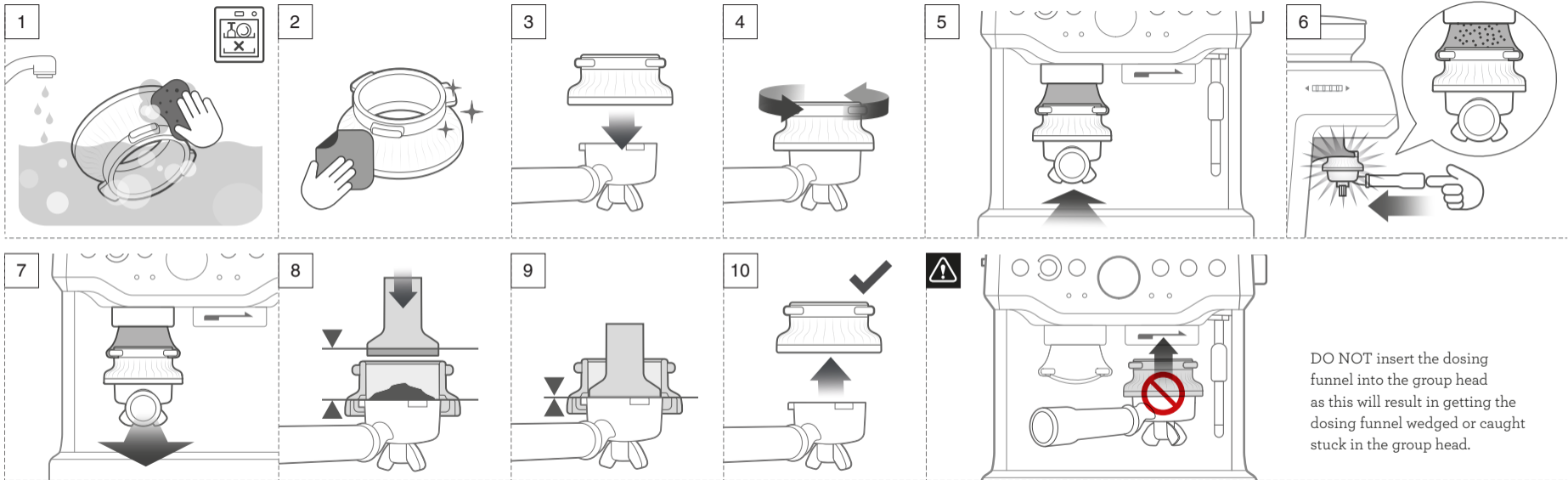



Troubleshooting

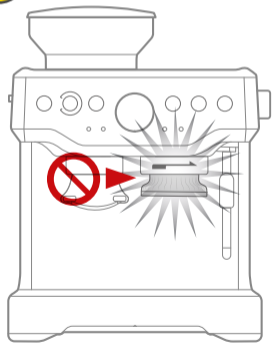

1

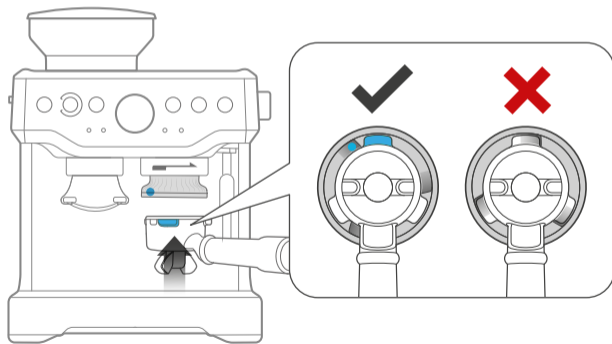

2

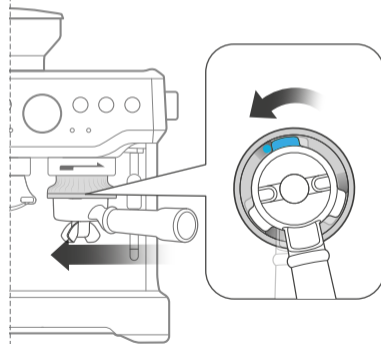

3

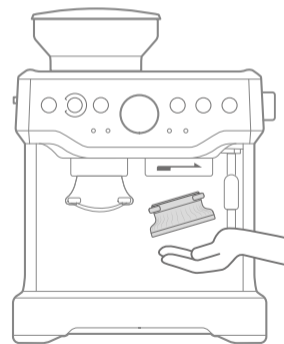

1 YEAR LIMITED PRODUCT WARRANTY

During the design and engineering of this product, quality was at the forefront of each material and component choice we made, which is why we proudly stand by it with a 1 Year Limited Product Warranty.

In Australia our goods come with guarantees that cannot be excluded under the Australian Consumer Law. You are entitled to a replacement or refund for a major failure and for compensation for any other reasonably foreseeable loss or damage. You are also entitled to have the goods repaired or replaced if the goods fail to be of acceptable quality and the failure does not amount to a major failure.

In New Zealand our goods come with guarantees that cannot be excluded under the Consumer Guarantees Act 1993.

So, as well as your statutory rights referred to above and any other rights and remedies you may have under any other laws relating to your Breville product, we also provide you with a Breville warranty. It's important to note that this warranty is valid only in the country of purchase. However, in other countries it is possible that other statutory warranties may still apply.

Breville's warranty for this product covers the repair or replacement (at Breville's discretion) if it's found to be defective due to faulty materials, workmanship, or function within the warranty period and will not extend the term of the original product warranty period.

To the extent permitted by law, this Breville Limited Product Warranty excludes liability for consequential loss or any other loss or damage caused to property or persons arising from any cause whatsoever. It excludes defects caused by the product not being used in accordance with instructions, by accidental damage, by misuse, or by being modified, altered, or tampered with by unauthorised persons. It excludes damage caused by insects or vermin and claims based on the presence of insects or vermin. It also excludes breakables such as glass and ceramic items, consumable items such as those that require periodic replacement as part of the ordinary use, lack of care or maintenance of the product or as directed by the instruction booklet,

minor cosmetic issues (including, without limitation, paint and coatings) and normal wear and tear, and does not cover the cost of claiming under the warranty or transporting the goods to and from the place of purchase. For support with your Breville product or to make a claim under the Breville Warranty please contact our Breville Customer Care Team on:

Australia: 1300 139 798
New Zealand: 0800 273 845

Our Breville Customer Care Team can often diagnose and resolve most issues over the phone. In the event your product needs to be inspected or repaired, our Breville Customer Care Team will assist in arranging shipping at no charge by providing you a pre-paid label or nearest drop off point. Once the item is received and the nature of the fault is determined we'll advise what remedy you may be entitled to under the Breville Warranty.

To obtain benefits under this Product Warranty, you will need to provide a proof of purchase in a form sufficient for us to verify your purchase, including the product, date of purchase and purchase price. We therefore urge you to retain this portion of the warranty card and the purchase receipt during the warranty period.

And if for any reason you wish to contact us in writing, please do so at:

Breville Customer Service Centre Australia Locked Bag 2000 Botany NSW 1455	Breville Customer Service Centre New Zealand PO Box 99027 Newmarket 1149, Auckland
---	---

Or click on Support at www.breville.com

Breville®

Master Every Moment™

www.breville.com

Breville, the Breville logo and Dosing Funnel are trademarks of Breville Pty Ltd. All other brands may be trademarks of their respective owners. Breville's products are distributed in Australia and New Zealand under license. A.B.N. 98 000 092 928. Approved by the appropriate electrical supply authorities. Backed by Breville 1 Year Replacement Warranty and nation-wide service network.

Made in China to our specifications.

Due to continued product improvement, the product illustrated on this carton may vary slightly from the actual product.

BEA201 ANZ WEB_ONLY A22