

CAFÉ RACER



Technical data		2 GROUP	3 GROUP 32AMP	3 GROUP 40AMP
voltage	V	220-240 1N 50/60Hz or 380-415 3N 50/60Hz		
required amperage	A	32	32	40
power input	kW	6.9	6.3	8.4
steam boiler capacity	lt	8	10	10
steam boiler element	kW	3.5	3.5	4.5
pump power	kW	0.165	0.165	0.165
pre-heating boiler capacity	lt (T)	1	1.5	1.5
pre-heating boiler element	kW (T)	1	1.5	1.5
cup-warmer power	kW	0.16	0.2	0.2
group boiler capacity	lt (T)	1	1.5	1.5
group boiler element	kW (T)	1.6	2.4	2.4
net weight	kg	97	120	120

Features



AISI 316L STAINLESS STEEL PORTAFILTER WITH "COMPETITION FILTER"

Exclusive Sanremo design, with shape and volume designed to capture the best coffee aromas



AISI 316L STAINLESS STEEL "COOL TOUCH" STEAM WANDS

Anti-burning feature even in conditions of prolonged use, fitted with "Latte Art" high-performance steam terminals.



AISI 316L STEEL GROUPS WITH 8KG OF PURE STEEL

Exclusive Sanremo design ensure exceptional thermal stability and maximum resistance to oxidation and limescale.



AISI 316L STEEL FREE MOTION STEAM TAPS

Flexible control system for producing and dispensing steam.



ADJUSTABLE DRIP TRAY

Innovative Sanremo "All in one" suspension system that allows for cups of different shapes and heights



EXTERNAL HIGH PERFORMANCE VOLUMETRIC PUMP 300L/H

Pressure stability in situations of prolonged use of multiple groups even in high turnover venues.



AUTO-ON, AUTO-OFF AND DAY-OFF FUNCTION

Programmable on-off timer for each day and/or daily timetables.



MIXED INFUSION HOT WATER TAP FOR TEA

Instantaneous mixing of fresh water and steam for optimal water quality.



HIGH PERFORMANCE FLOWMETERS

For an accurate and precise coffee dose in the cup.



INDEPENDENT ADJUSTMENT OF THE PID INFUSION WATER TEMPERATURE

Precision setting (gradient ± 0.5 °C with measured constancy lower than 0.2°C).



PROGRAMMABLE ELECTRONIC SOFT PRE-INFUSION

Allows control with 0.1 second tolerance of the flow of water that wets the coffee bed, with programming of 4 different



BOILER WATER REGENERATION

Ensures resetting of the optimum chemical characteristics of the water and correct mineralisation.



ENERGY SAVING SYSTEM

Insulation and smart energy management to save up to 30% of energy



AUTO-DIAGNOSIS, DATA COLLECTION, SCHEDULED MAINTENANCE

Maintenance can be scheduled according to litres or number of coffees dispensed.



PROGRAMMABLE CUP WARMER TEMPERATURE

Allows the cups to be kept at optimal temperature, even in different climates.



LED LIGHTING OF THE WORK AREA

Allows efficient working in any condition of environmental lighting.



CAFÉ RACER



Versions and Dimensions

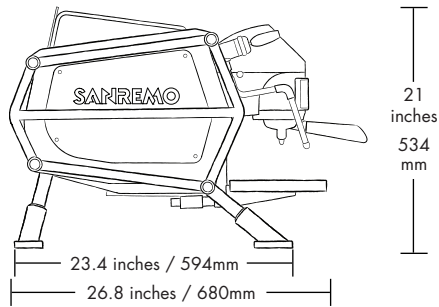

2 GROUP	3 GROUP
2 steam taps	2 steam taps
1 water tap	1 water tap
1 one-cup portafilter	1 one-cup portafilter
2 two-cup portafilters	3 two-cup portafilters

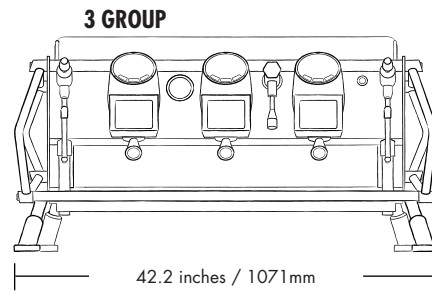
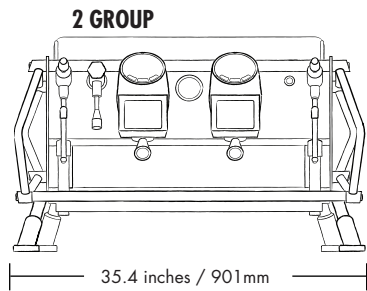

Individual Grouphead Display

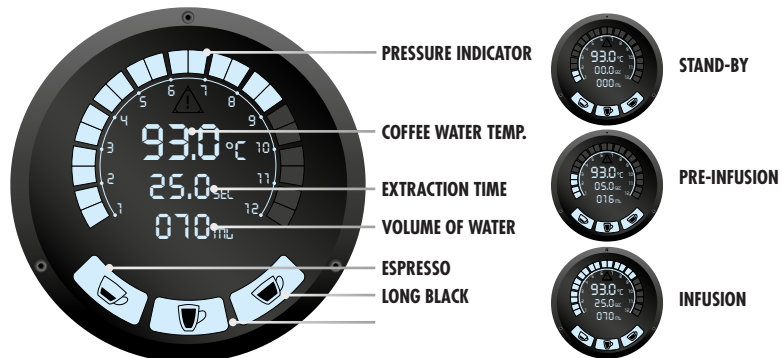

Colours

	Naked Black		Racing
	Full White		Dolomiti Black (black leather)
	White Wood		Renegade Green (brown leather)



All images are subject to illustrative purpose. The manufacturer reserves the right to modify without prior notice the technical characteristics indicated in this document.

CONTACT US

info@sanremomachines.com.au
sanremomachines.com.au

