

-CUSTOM TAILORED-

# TAYLOR STITCH

---

HANDMADE IN THE USA BY  
L. GAMBERT SHIRTMAKERS  
SINCE 1933

.....

*SHIRTING  
STYLE  
GUIDE*

## *Design Your Shirt*

---

The character of a shirt is created through a design process involving five main elements. A thoughtful arrangement of these details will create a shirt that perfectly reflects one's purpose and personality.



*Measurements*



*Placket*



*Collar*



*Pocket*



*Cuff*



*Templates*

## *Design Your Shirt*

---

Further options of customization for the sartorially adventurous individual.



*Contrast Fabrics + \$20*



*Contrast Stitch + \$10*



*Monogram + \$10*



## Get Measured

.....

There are nine body measurements taken before creating the pattern for your shirt. Once your measurements have been recorded, we will go through styling your shirt. Your measurements will be archived for any future orders.

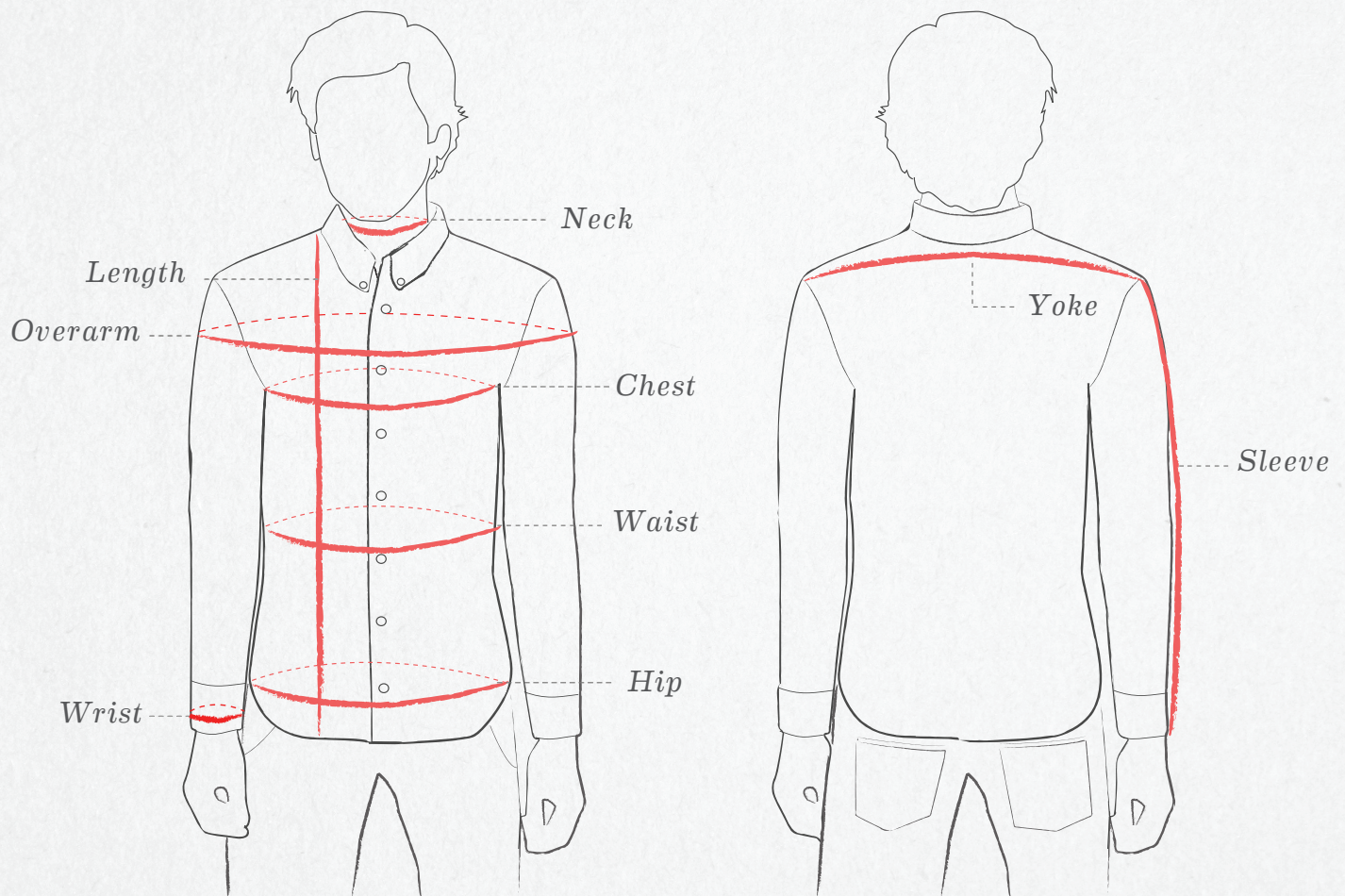



## *Collars*

---

### ***Button Down***

Our own take on the button down: A bit shorter point lengths, give it a youthful and modern look

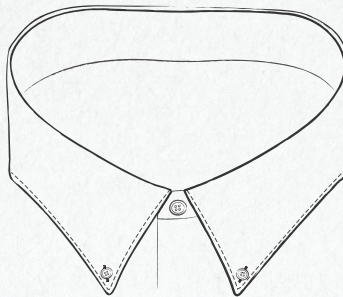

### ***Buddy Holly***

Our most contemporary collar, it is inspired by 50's rock and roll. A perfect vintage style re-appropriation.

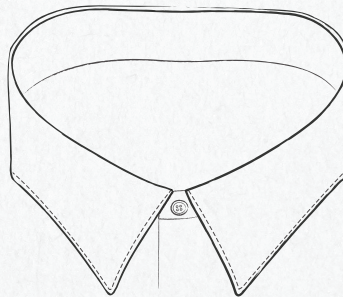

### ***Classic***

Perfect for all occasions, outfits and facial structures. This collar is the foundation of the original 60's suited advertising look.

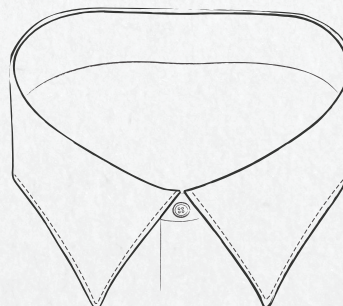



## *More Collars*

---

### ***English***

An Anglo accent to the spread collar without being a full cutaway. Perfect for finer occasions. Balances narrower faces.

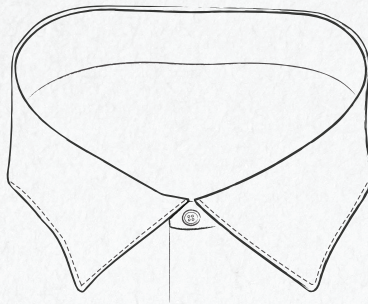

### ***Cutaway***

A dandified collar. There is nothing quite like perfectly pulling this collar off with the right outfit.

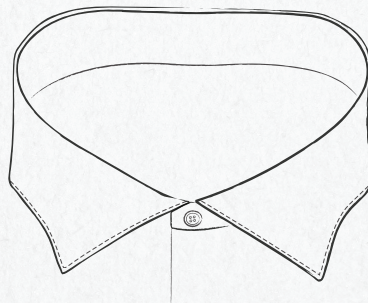

### ***Club***

Once reserved for bankers and barons. This collar has resurfaced at the forefront of contemporary style.

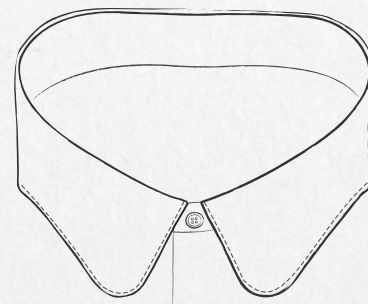



## Cuffs

---

*Single Button Rounded:*

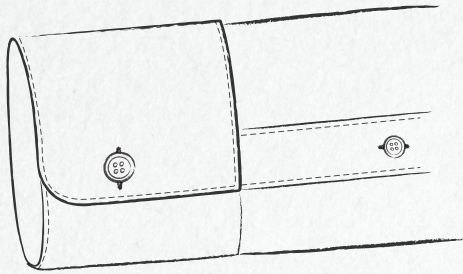

*Double Button Rounded:*

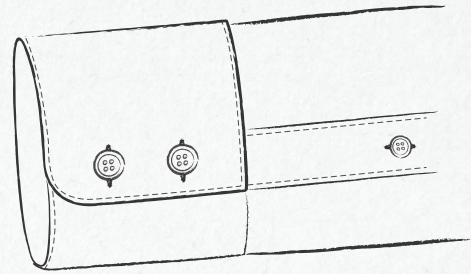

*Single Button Angled:*

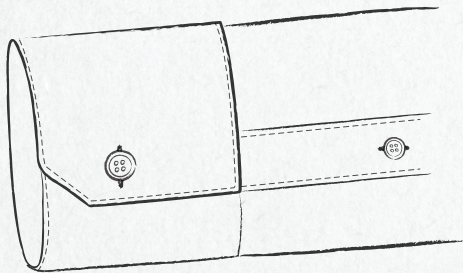

*Double Button Angled:*

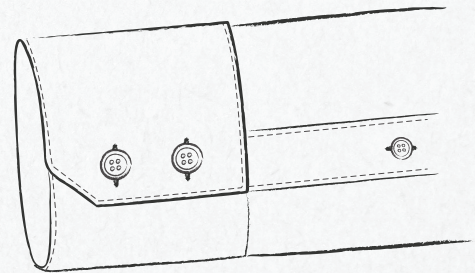

*Square French:*

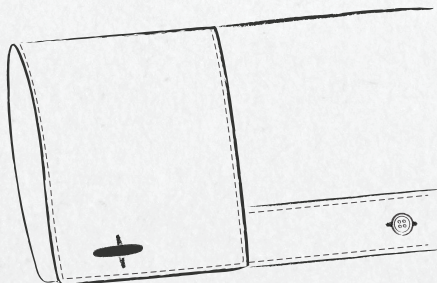

*Angled French:*

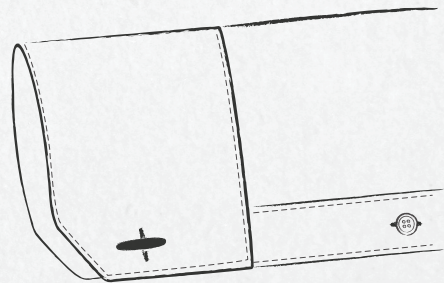



## *Placket*



### ***Pleated***

A classic Americana look that breaks up the front of the shirt making it a bit more casual

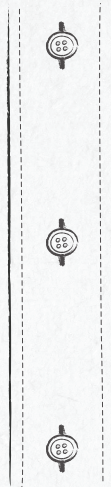

### ***Pleated***

A clean and more contemporary look that is a nice choice for a more formal shirt.





## *Pocket*

---

### ***Rounded***

Matched with a rounded cuff.



### ***Angled***

Matched with a angled cuff.

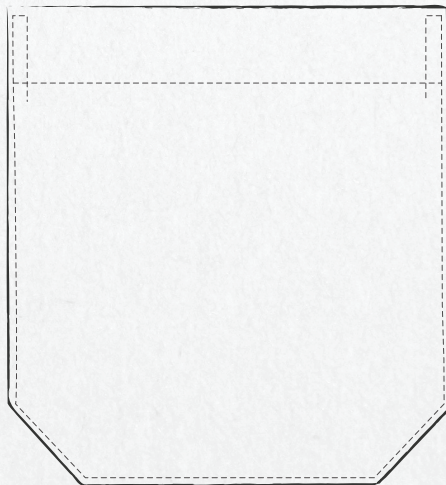





## Style Templates

---

### **The Button Down**

A little shorter point lengths, It is younger and more adaptable. This style generally casual but can be easily be dressed up.

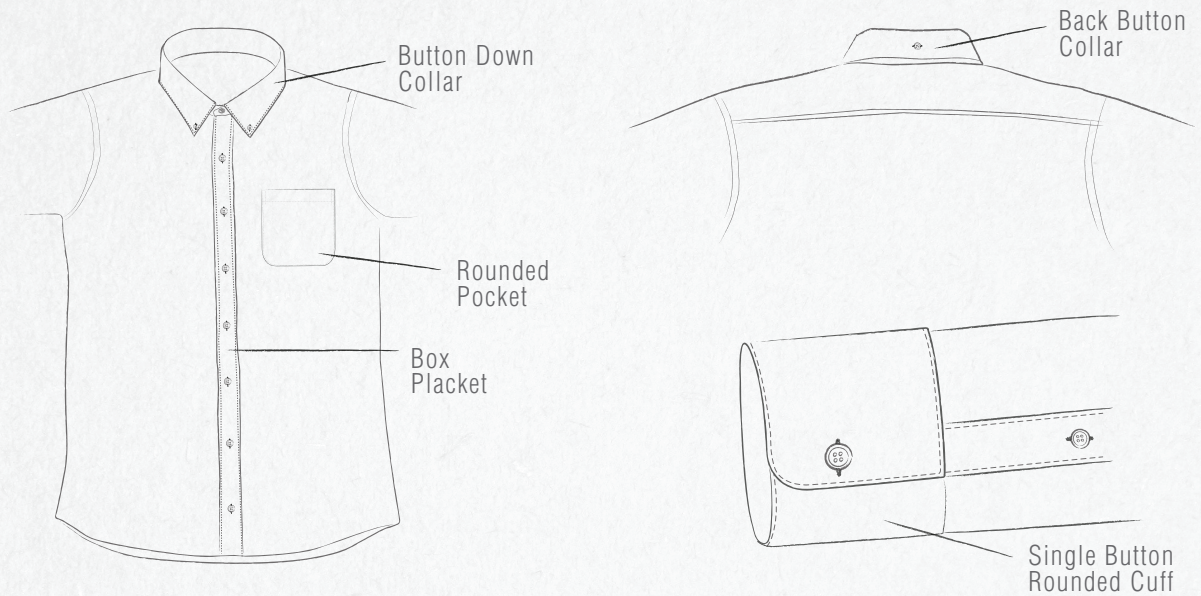

### **The Buddy Holly**

Inspired by 50's rock and roll. A perfect vintage style re-appropriation.

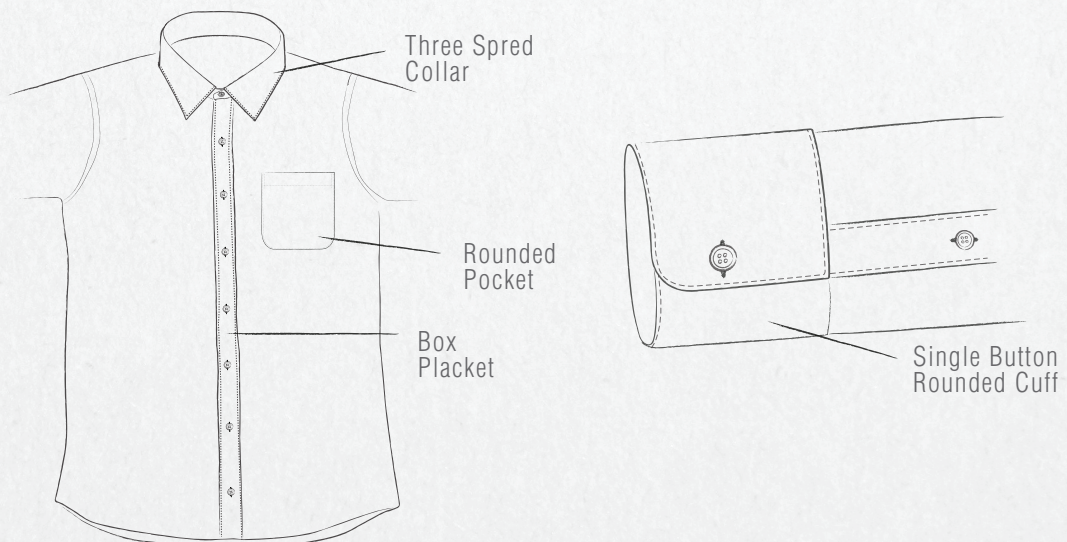



## Style Templates

---

### **Classic**

Perfect for all occasions, outfits and facial structures. This collar is the foundation of the original 60's suited advertising look.

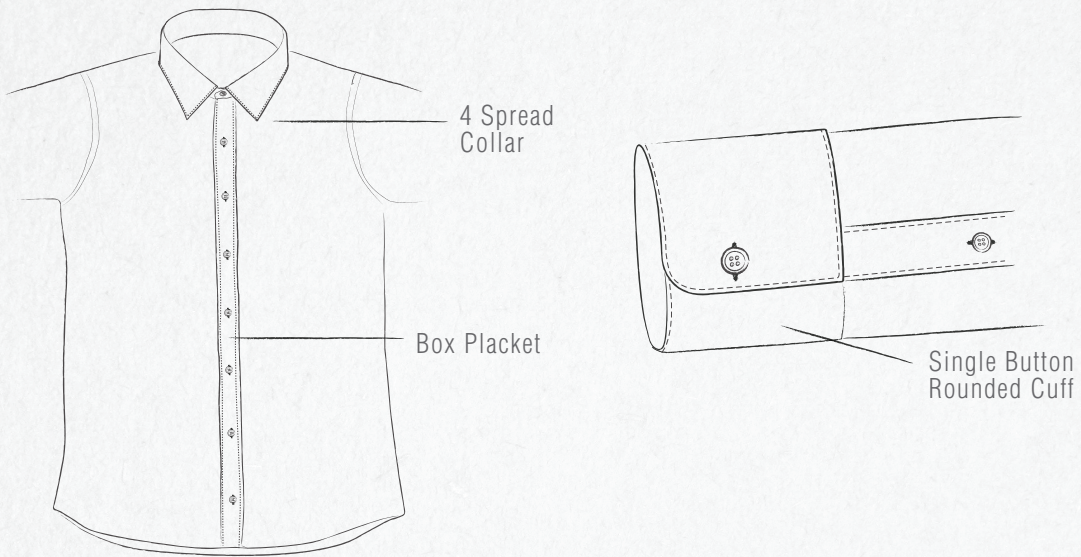

### **The English**

An anglo-American accent. A bit more collar spread without being a full cutaway. Perfect for nicer occasions. Balances a narrower face.

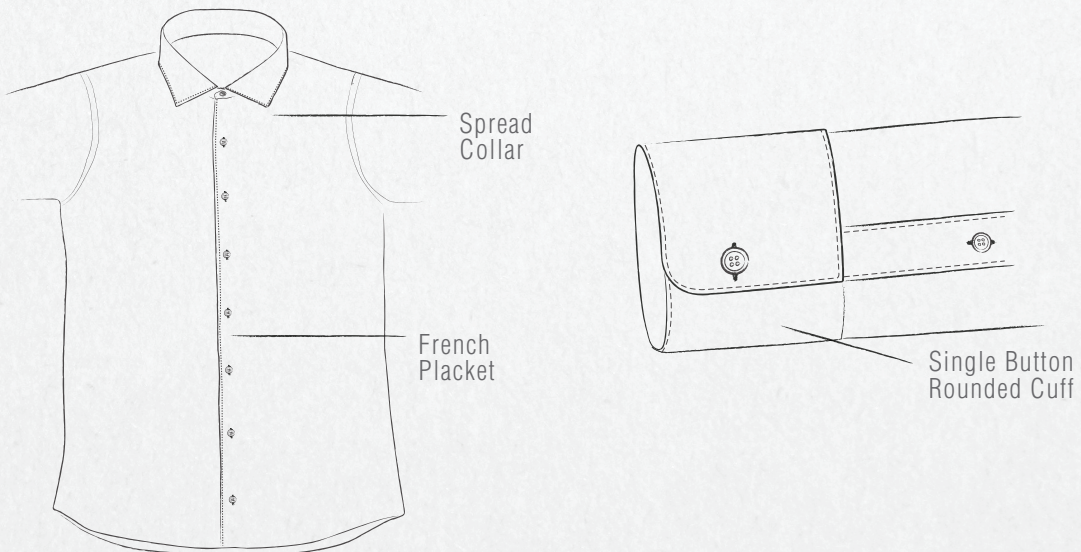



## Style Templates

---

### **Formal**

A new take on the tuxedo shirt. It stays functional when you aren't sporting your monkey suit and just need to dress up.

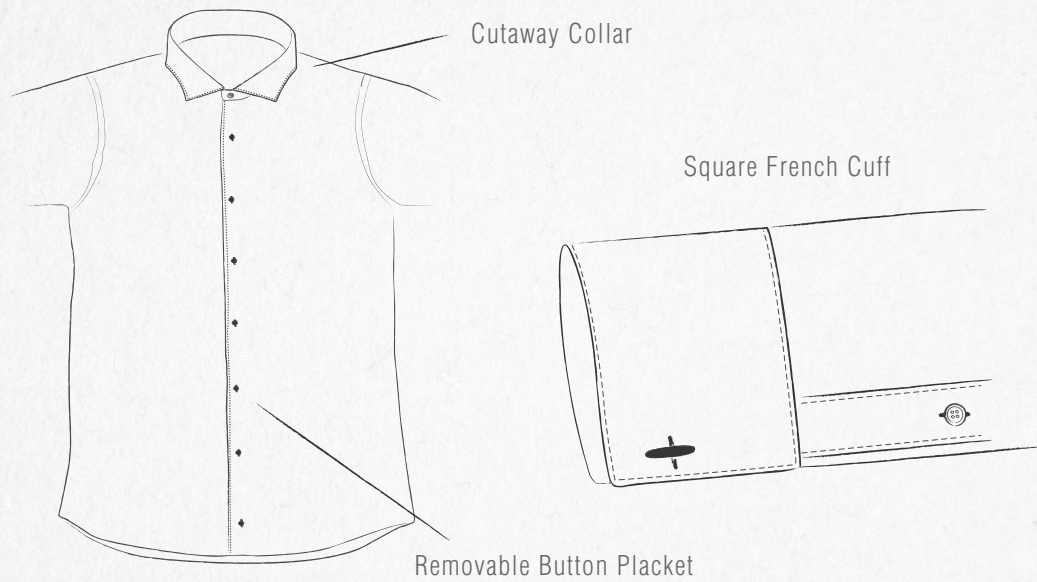



## *Contrast Fabrics*

***Additional \$20***

Interior of cuff:

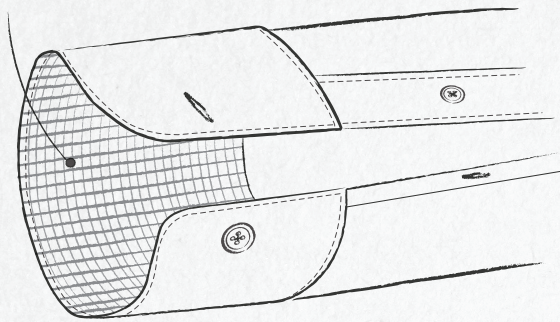

Interior of collar:

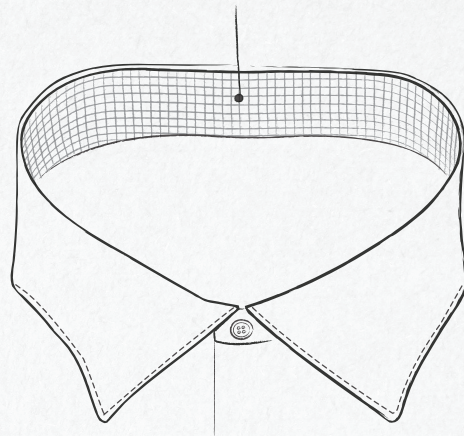

## *Contrast Stitching*

***Additional \$20***

sleeve placket button holes

