

Products Specification

NiCOLE Commercial Induction Cooktops

Shabu / Yakiniiku / Dining Hall / Food Warmer / Buffet Line

INDUCTION COMMERCIAL COOKTOP AT128B

Commercial Induction Cooktop for 1 Seater

KEY FEATURES

8 Levels of Power Control

Work continuously for 12 hours with
Advanced Thermal Management system by NiCOLE®

NiCOLE® Safety Features

- Pot Detection Element will operate only when appropriate cookware is placed.
- Heat Sensor Element will stop operate when hardware or cooktop is overheated.
- Voltage Control Element will stop operate when voltage is unstable.

Cooker stays relatively cold added for safety and cleanup.

Exceptional customer service and product warranty.



PRODUCT SPECIFICATION

Model	AT-128B-800	AT-128B-650	AT-128B-500
Electric Power	800 Watt	650 Watt	500 Watt
Electrical Supply	220-240V 50/60 Hz		
Amparage - A	3.6	3.0	2.3
Power Level	8 Levels		
Control	Touch Control or Remote Control		
Dimension			
Width	175 mm		
Depth	215 mm		
Height	70 mm		

DIMENSION

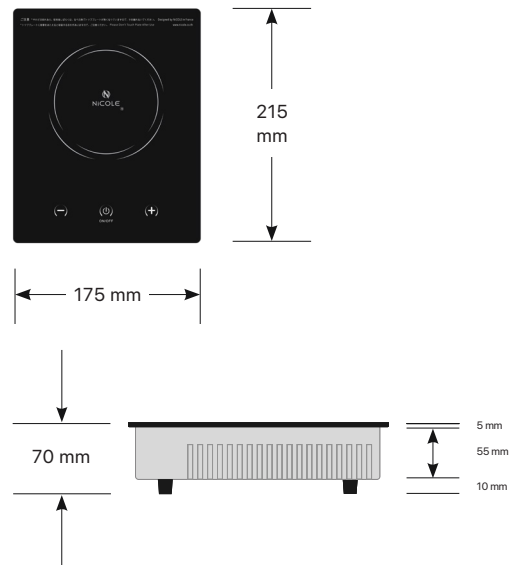

BASIC INSTALLATION DIMENSION

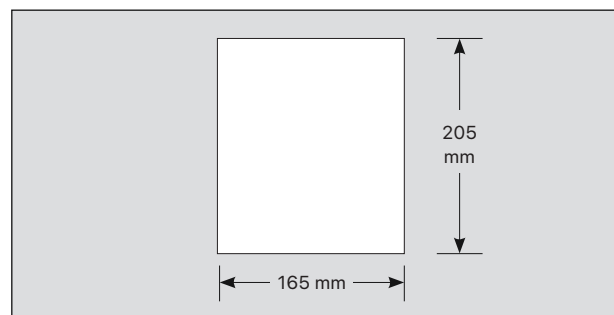

COUNTERTOP CUT-OUT SIZE

Shabu / Yakiniku / Dining Hall / Food Warmer / Buffet Line

INDUCTION COMMERCIAL COOKTOP AT698A

Commercial Induction Cooktop for 4-6 Seaters

KEY FEATURES

8 Levels of Power Control

Work continuously for 12 hours with Advanced Thermal Management system by NiCOLE®

NiCOLE® Safety Features

- Pot Detection Element will operate only when appropriate cookware is placed.
- Heat Sensor Element will stop operate when hardware or cooktop is overheat.
- Voltage Control Element will stop operate when voltage is unstable.

Cooker stays relatively cold added for safety and cleanup.

Exceptional customer service and product warranty.



PRODUCT SPECIFICATION

Model	AT-698A-18	AT-698A-15	AT-698A-12
Electric Power	1800 Watt	1500 Watt	1200 Watt
Electrical Supply	220-240V 50/60 Hz		
Amparage - A	8.1	6.8	5.4
Power Level	8 Levels		
Control	Touch Control or Remote Control		
Dimension			
Width	300 mm		
Depth	300 mm		
Height	74 mm		

DIMENSION

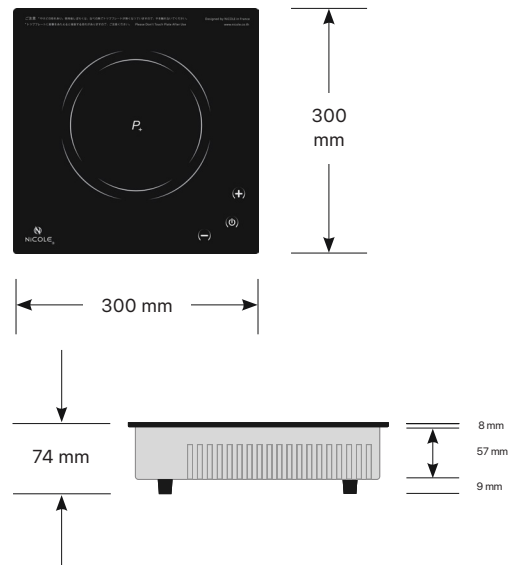

BASIC INSTALLATION DIMENSION

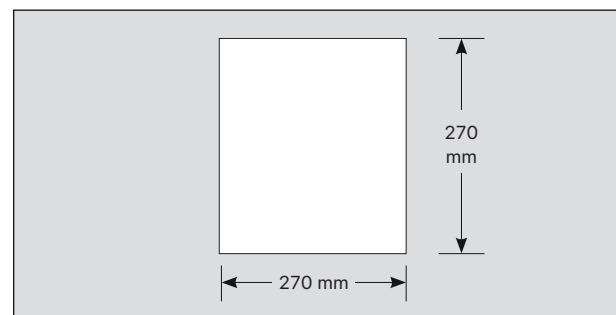

COUNTERTOP CUT-OUT SIZE

Shabu / Yakimiku / Dining Hall / Food Warmer / Buffet Line

INDUCTION COMMERCIAL COOKTOP AT588A

Commercial Table Top Induction Cooktop for 4-6 Seater

KEY FEATURES

8 Levels of Power Control

Work continuously for 12 hours with Advanced Thermal Management system by NiCOLE®

NiCOLE® Safety Features

- Pot Detection Element will operate only when appropriate cookware is placed.
- Heat Sensor Element will stop operate when hardware or cooktop is overheat.
- Voltage Control Element will stop operate when voltage is unstable.

Cooker stays relatively cold added for safety and cleanup.

Exceptional customer service and product warranty.



PRODUCT SPECIFICATION

Model	AT-588A-20	AT-588A-18	AT-588A-15	AT-588A-12
Electric Power	2000 Watt	1800 Watt	1500 Watt	1200 Watt
Electrical Supply	220-240V 50/60 Hz			
Amparage - A	9.0	8.1	6.8	5.4
Power Level	8 Levels			
Control	Touch Control			
Dimension				
Width	290 mm			
Depth	360 mm			
Height	70 mm			

DIMENSION

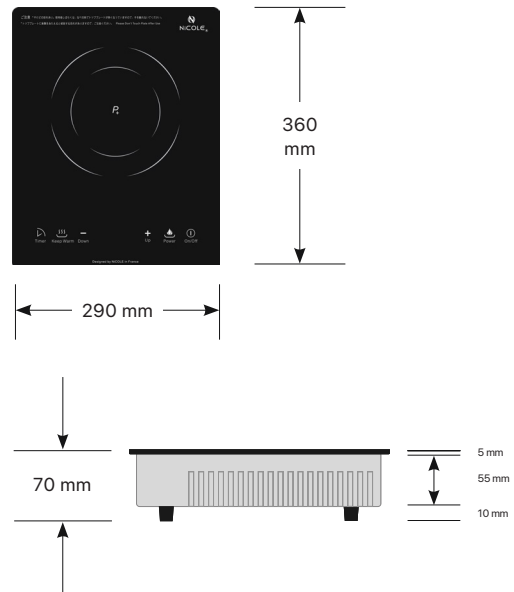

BASIC INSTALLATION DIMENSION

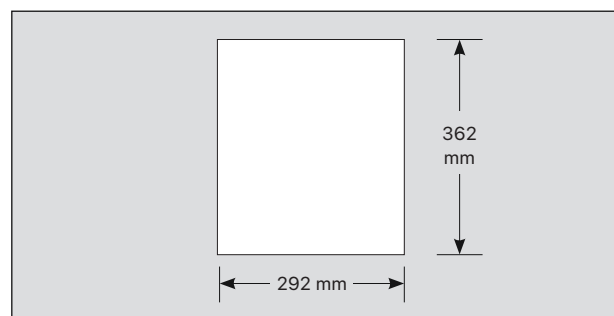

COUNTERTOP CUT-OUT SIZE

Shabu / Yakiniku / Dining Hall / Food Warmer / Buffet Line

INDUCTION COMMERCIAL COOKTOP AT2X Series

High Performance Fe Frame Commercial Induction Cooktop

KEY FEATURES

8 Levels of Power Control

Work continuously for 12 hours with
Advanced Thermal Management system by NiCOLE®

NiCOLE® Safety Features

- Pot Detection Element will operate only when appropriate cookware is placed.
- Heat Sensor Element will stop operate when hardware or cooktop is overheat.
- Voltage Control Element will stop operate when voltage is unstable.

Cooker stays relatively cold added for safety and cleanup.

Exceptional customer service and product warranty.



PRODUCT SPECIFICATION

Model	AT-20A	AT-25A
Electric Power - kW	2.0 kW	2.5 kW
Electrical Supply	220-240V 50/60 Hz	
Amparage - A	9.0	11.4
Power Level	8 Levels	
Control	Touch Control	
Dimension		
Width	320 mm	
Depth	380 mm	
Height	68 mm	

DIMENSION

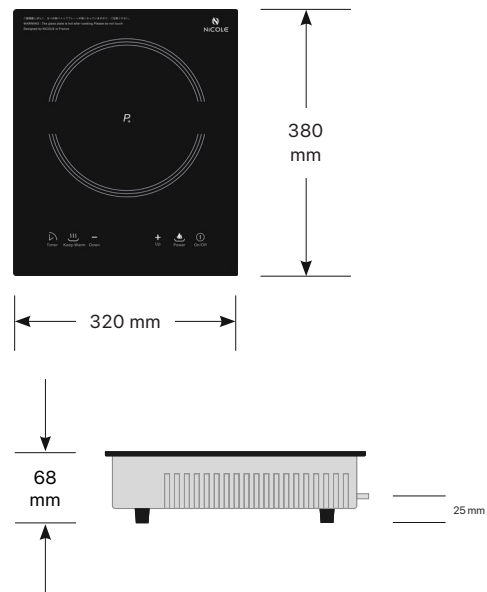

BASIC INSTALLATION DIMENSION

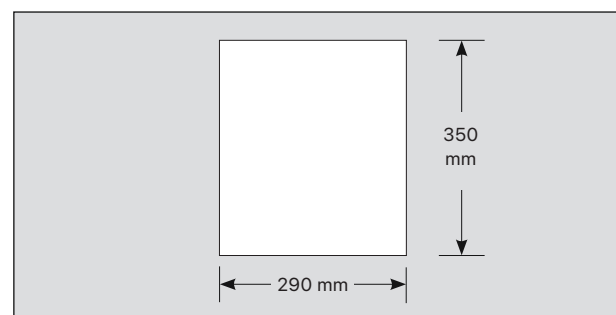

COUNTERTOP CUT-OUT SIZE

Kitchen / Dining Hall / Food Warmer / Buffet Line

INDUCTION COMMERCIAL COOKTOP AT3630

High Performance Fe Frame Commercial Induction Cooktop

KEY FEATURES

8 Levels of Power Control

Work continuously for 12 hours with
Advanced Thermal Management system by NiCOLE®

NiCOLE® Safety Features

- Pot Detection Element will operate only when appropriate cookware is placed.
- Heat Sensor Element will stop operate when hardware or cooktop is overheat.
- Voltage Control Element will stop operate when voltage is unstable.

Cooker stays relatively cold added for safety and cleanup.

Exceptional customer service and product warranty.



PRODUCT SPECIFICATION

Model	AT-3630-30	AT-3630-25	AT-3630-20
Electric Power - kW	3.0 kW	2.5 kW	2.0 kW
Electrical Supply	220-240V 50/60 Hz		
Power Level	8 Levels		
Control	Remote Control		
Dimension			
Width	360 mm		
Depth	360 mm		
Height	90 mm		

DIMENSION

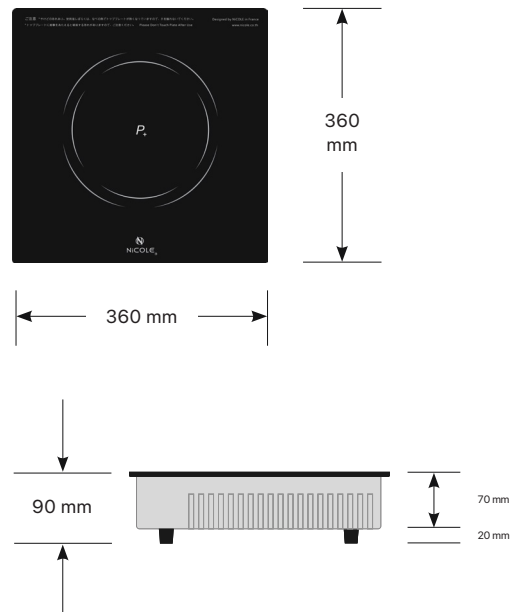

BASIC INSTALLATION DIMENSION

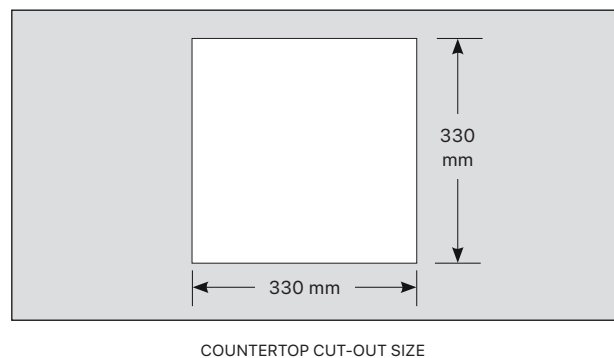

Kitchen / Dining Hall / Food Warmer / Buffet Line

**INDUCTION COMMERCIAL COOKTOP
AT3434**

High Performance Fe Frame Commercial Induction Cooktop

KEY FEATURES

8 Levels of Power Control

Work continuously for 12 hours with
Advanced Thermal Management system by NiCOLE®

NiCOLE® Safety Features

- Pot Detection Element will operate only when appropriate cookware is placed.
- Heat Sensor Element will stop operate when hardware or cooktop is overheat.
- Voltage Control Element will stop operate when voltage is unstable.

Cooker stays relatively cold added for safety and cleanup.

Exceptional customer service and product warranty.



PRODUCT SPECIFICATION

Model	AT-3434-30	AT-3434-25	AT-3434-20
Electric Power - kW	3.0 kW	2.5 kW	2.0 kW
Electrical Supply	220-240V 50/60 Hz		
Power Level	8 Levels		
Control	Remote Control		
Dimension			
Width	340 mm		
Depth	340 mm		
Height	90 mm		

DIMENSION

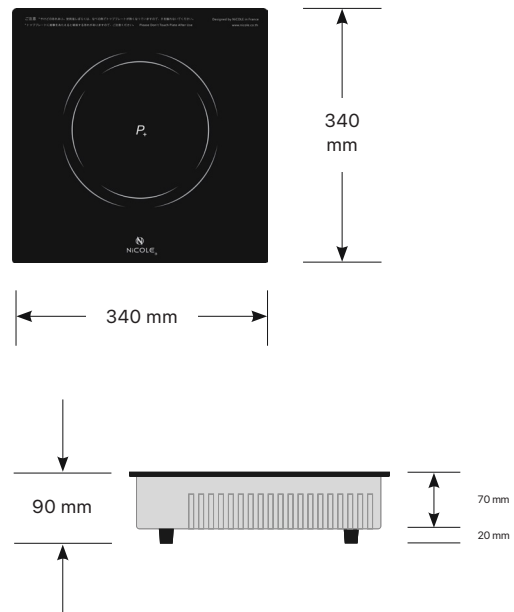

BASIC INSTALLATION DIMENSION

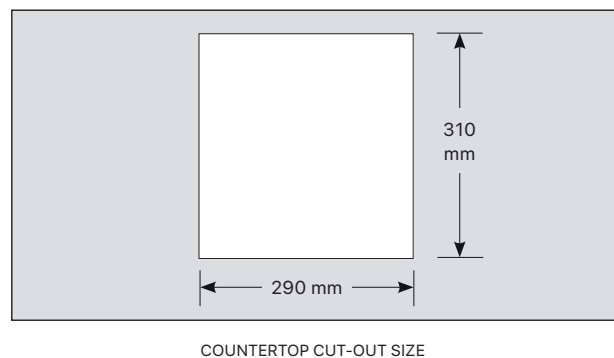

COUNTERTOP CUT-OUT SIZE

Kitchen / Dining Hall / Food Warmer / Buffet Line

INDUCTION COMMERCIAL COOKTOP AT3432

High Performance Fe Frame Commercial Induction Cooktop

KEY FEATURES

8 Levels of Power Control

Work continuously for 12 hours with Advanced Thermal Management system by NiCOLE®

NiCOLE® Safety Features

- Pot Detection Element will operate only when appropriate cookware is placed.
- Heat Sensor Element will stop operate when hardware or cooktop is overheat.
- Voltage Control Element will stop operate when voltage is unstable.

Cooker stays relatively cold added for safety and cleanup.

Exceptional customer service and product warranty.



PRODUCT SPECIFICATION

Model	AT-3432-30	AT-3432-25	AT-3432-20
Electric Power - kW	3.0 kW	2.5 kW	2.0 kW
Electrical Supply	220-240V 50/60 Hz		
Power Level	8 Levels		
Control	Remote Control		
Dimension			
Width	320 mm		
Depth	340 mm		
Height	90 mm		

DIMENSION

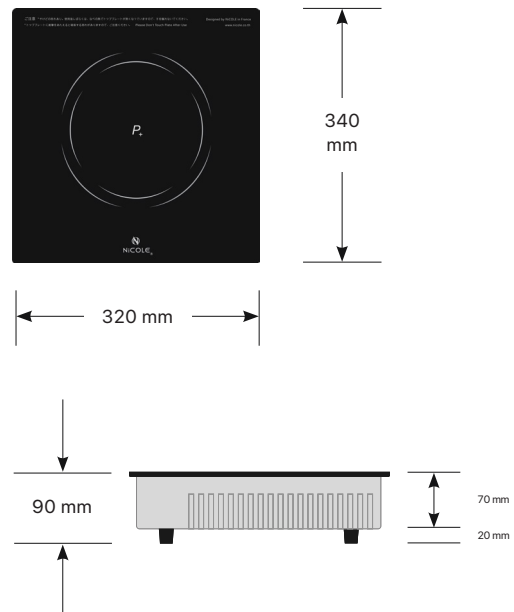

BASIC INSTALLATION DIMENSION

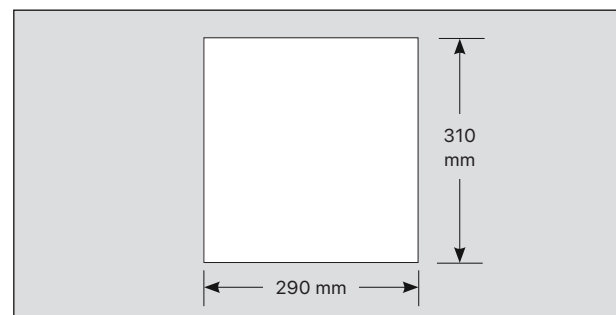

COUNTERTOP CUT-OUT SIZE

Kitchen / Dining Hall / Food Warmer / Buffet Line / Boba and Milk Tea

INDUCTION COMMERCIAL COOKTOP AT35A

High Performance Stainless Cooktop

KEY FEATURES

8 Levels of Power Control

Work continuously for 12 hours with Advanced Thermal Management system by NiCOLE®

NiCOLE® Safety Features

- Pot Detection Element will operate only when appropriate cookware is placed.
- Heat Sensor Element will stop operate when hardware or cooktop is overheat.
- Voltage Control Element will stop operate when voltage is unstable.

Cooker stays relatively cold added for safety and cleanup.

Exceptional customer service and product warranty.



PRODUCT SPECIFICATION

Model	AT-35A
Electric Power - kW	3.5 kW
Electrical Supply	220-240V 50/60 Hz
Power Level	8 Levels
Control	Touch Control
Dimension	
Width	360 mm
Depth	450 mm
Height	140 mm

DIMENSION

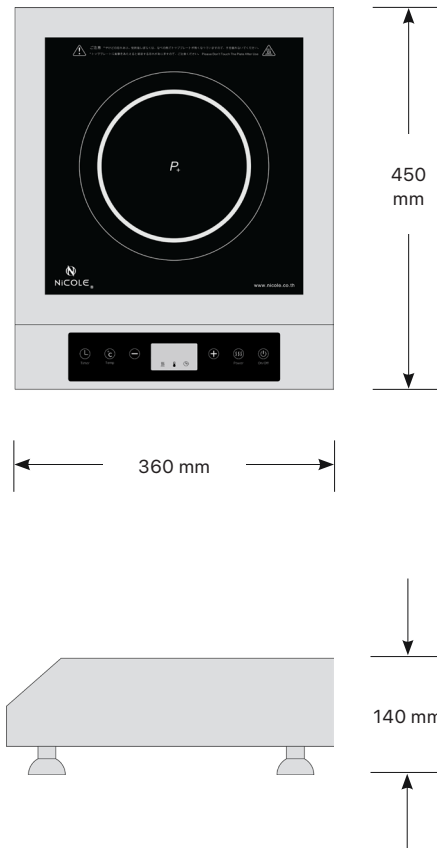

Kitchen / Dining Hall / Food Warmer / Buffet Line / Boba and Milk Tea

INDUCTION COMMERCIAL COOKTOP 5X Series

High Performance Stainless Cooktop

KEY FEATURES

8 Levels of Power Control

Work continuously for 12 hours with
Advanced Thermal Management system by NiCOLE®

NiCOLE® Safety Features

- Pot Detection Element will operate only when appropriate cookware is placed.
- Heat Sensor Element will stop operate when hardware or cooktop is overheat.
- Voltage Control Element will stop operate when voltage is unstable.

Cooker stays relatively cold added for safety and cleanup.

Exceptional customer service and product warranty.



PRODUCT SPECIFICATION

Model	AT-50W	AT-50B
Cooking Surface	Wok Type	Frameless Ceramic
Electric Power - kW	5 kW	5 kW
Electrical Supply	220-240V 50/60 Hz	220-240V 50/60 Hz
Power Level	8 Levels	8 Levels
Control	Touch Controll	Touch Control
Dimension		
Width	405 mm	405 mm
Depth	500 mm	500 mm
Height	200 mm	200 mm

DIMENSION

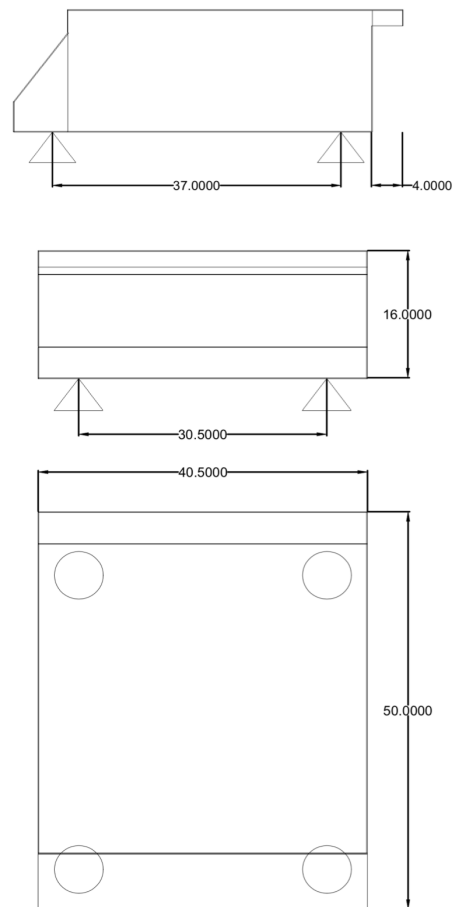

Precision Temperature Control

INDUCTION COMMERCIAL COOKTOP T5

High Performance Precision Temperature Control Cooktop

KEY FEATURES

14 Levels of Power Control, with Precise Temp Control 40C-200C

Work continuously for 12 hours with Advanced Thermal Management system by NiCOLE®

NiCOLE® Safety Features

- Pot Detection Element will operate only when appropriate cookware is placed.
- Heat Sensor Element will stop operate when hardware or cooktop is overheat.
- Voltage Control Element will stop operate when voltage is unstable.

Cooker stays relatively cold added for safety and cleanup.

Exceptional customer service and product warranty.



PRODUCT SPECIFICATION

Model	T5
Electric Power - kW	2.5kW
Electrical Supply	220-240V 50/60 Hz
Power Level	14 Levels
Control	Touch Control
Dimension	
Width	300 mm
Depth	380 mm
Height	55 mm

DIMENSION

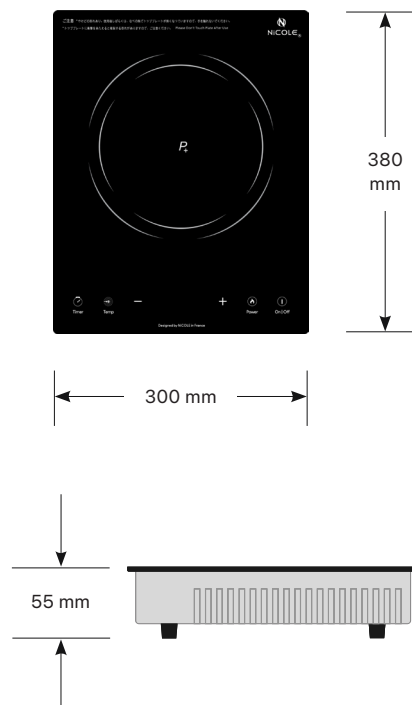

COMERCIAL INFRARED COOKTOP IF-202

20 Levels Infrared Cooktop

KEY FEATURES

20 Levels of Power Control

Work continuously for 12 hours with Advanced Thermal Management system by NiCOLE®

NiCOLE® Safety Features

Heat Sensor Element will stop operate when hardware or cooktop is overheat.

Voltage Control Element will stop operate when voltage is unstable.

Maintain Precise Power to keep food in prefer temperature.

Exceptional customer service and product warranty.



PRODUCT SPECIFICATION

Model	IF-202
Electric Power - kW	2.0kW
Electrical Supply	220-240V 50/60 Hz
Power Level	20 Levels
Control	Touch Control
Dimension	
Width	280 mm
Depth	360 mm
Height	65 mm

DIMENSION

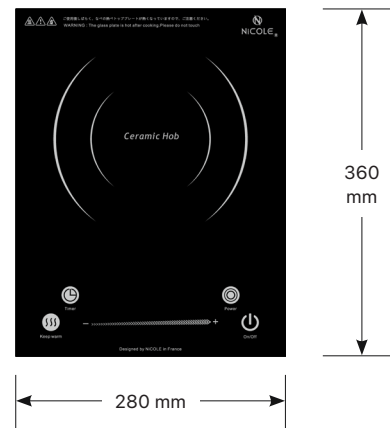

COMMERCIAL INFRARED COOKTOP IF-288

20 Levels Infrared Cooktop

KEY FEATURES

20 Levels of Power Control

Work continuously for 12 hours with Advanced Thermal Management system by NiCOLE®

NiCOLE® Safety Features

Heat Sensor Element will stop operate when hardware or cooktop is overheat.

Voltage Control Element will stop operate when voltage is unstable.

Maintain Precise Power to keep food in prefer temperature.

Electric cooker frame is made with Stainless Steel

Exceptional customer service and product warranty.



PRODUCT SPECIFICATION

Model	IF-288
Electric Power - kW	2.2kW
Electrical Supply	220-240V 50/60 Hz
Power Level	20 Levels
Control	Remote Control
Dimension	
Width	288 mm
Depth	288 mm
Height	100 mm

DIMENSION

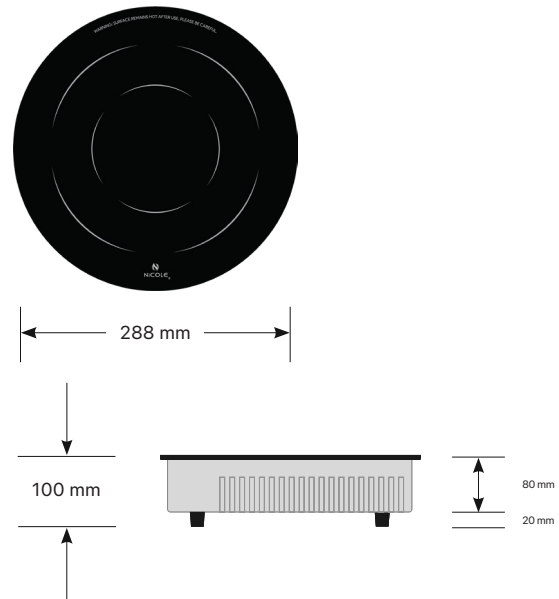

BASIC INSTALLATION DIMENSION

