

Cleanroom HEPA/ULPA Filters

East Coast Filter, Inc.'s Cleanroom HEPA/ULPA Filter Units are designed to be dropped into a standard or cleanroom ceiling system to efficiently clean the air. Available in both standard and custom sizes to meet any room requirement.

Each unit is available with a choice of either a 95%, 99.99% or 99.9995% efficiency HEPA or ULPA Filter. The included motorized impeller provides a lower profile than units with larger Centrifugal Blowers, but can still handle an additional 0.125" external static pressure.

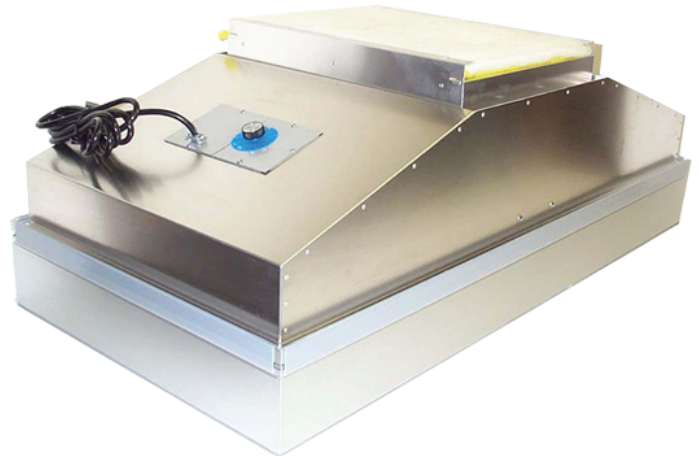

Features

- HEPA Filters at 0.3 Microns 99.99% Efficiency (Class 100 ISO Class 5)
- ULPA Filters at 0.12 Microns at 99.9995% Efficiency (Class 10 ISO Class 4)
- Brushed Aluminum Blower Housing
- Duct Collar/Prefilter
- Power Cord or Junction Box
- Variable Speed Control
- Integral White Powder Painted Expanded Metal Face Screen

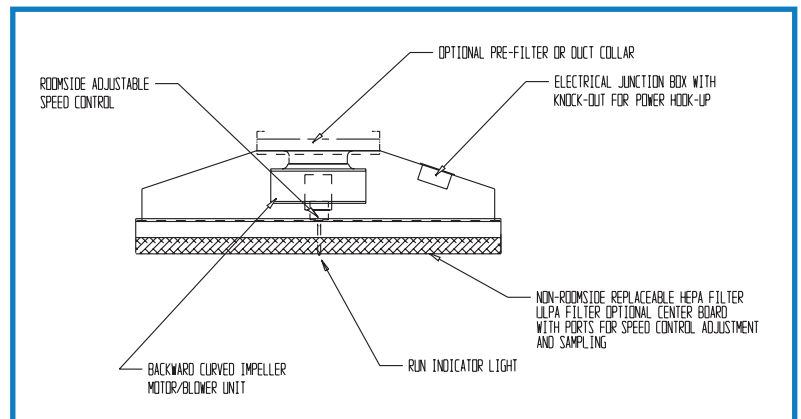

Specifications

- **Dimensions** - 24" x 24", 24" x 36", 24" x 48", Custom Sizes
- **Noise Level** - Less than 60 db
- **Velocity** - 90-100 FPM
- **Electrical** - 60 Cycles (or as Specified), 220 Volt/1 Phase, 110 Volt/1 Phase