

### Programmed with CodeSys Software

32-bit processor, 20 I/O (10 inputs & 10 outputs), 3 CAN interfaces  
supply voltage 6-32 VDC

The high-performance HCM20 control unit is designed for electronic control of all system functions on and off-highway mobile equipment. This control unit features a powerful processor, configurable CAN channels and a flexible I/O system to meet the needs of a variety of demanding applications.

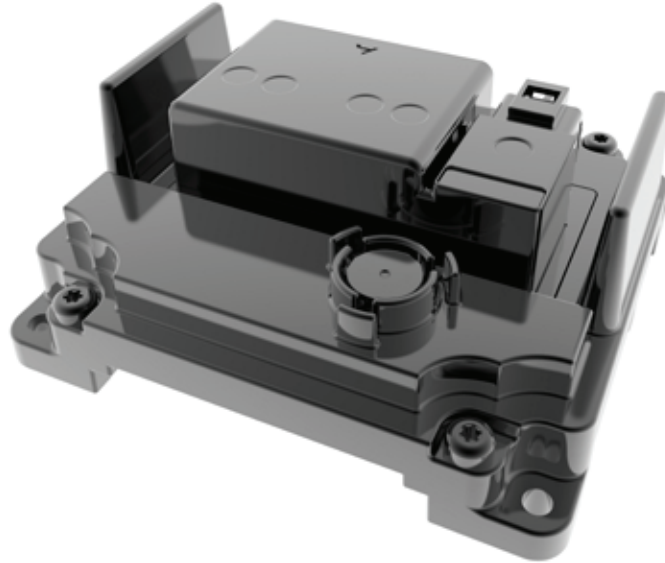

#### Technical data

Dimensions	L: 5.3 in (134.2 mm) x W: 5.8 in (146.2 mm) x H: 2.3 in (58.6 mm)
Weight	1.85 lbs (0.84 kg)
Storage temperature range	-40 - +125 °C
Operating temperature range	-40 - +105 °C(USB use is limited to 85°C)
IP rating	IP67, IP69k
Operating altitude	0 - 4000 m
Supply voltage	6 - 32 VDC, nominal operation @ 12 /24 VDC
Peak supply voltage	36 VDC
Maximum load current	20A @ 105°C (24A @ 85°C)
Standby current 12/24 VDC	<3.5 mA@12 V, <2.5 mA@24 V
Processor	32 bit, 200 MHz, Renesas Super H 72546
Floating point units	Integrated on chip
MRAM (additional to CPU)	32 Kbyte approx. 1 trillion writes
Flash (ROM program & data combined)	3.75 Mbyte 1000 writes
SRAM	256 Kbyte
EEPROM	128 Kbyte (system use only)

## Technical data

### Communications

---

CAN 1 interface	2.0A, 2.0B
Baud rates	125 kb/s, 250 kb/s, 500 kb/s, 1 Mb/s
Protocol	CANopen, J1939
Default node address	0
Default baud rate	250 kb/s

---

CAN 2 interface	2.0A, 2.0B
Baud rates	125 kb/s, 250 kb/s, 500 kb/s, 1 Mb/s
Protocol	CANopen, J1939

---

CAN 3 interface	2.0A, 2.0B
Baud rates	125 kb/s, 250 kb/s, 500 kb/s, 1 Mb/s
Protocol	CANopen, J1939

---

USB interface	USB 2.0 (Note: 3.0 devices are compatible), used for programming
Baud rates	1.5 Mb/s

---

### Sensor supply

---

Number of sensor supplies	1
Sensor supply output voltage	5/10 VDC (software configurable)
Sensor supply maximum current	200 mA @ 5 VDC, 100 mA @ 10 VDC per supply (Note: sensor supply is de-rated to 50 mA @ 10 VDC on 24 VDC systems with ambient temperatures at or above 85°C)

---

# Technical data

## Inputs

Digital input	Digital low/high side (software configurable)
Input frequency	200 Hz
Switch-on level	Software configurable
Switch-off level	Software configurable

Frequency input	Digital Low/high side (software configurable)
Input frequency	0 Hz - 50 kHz Note: maximum aggregate is 200 kHz, minimum detectable pulse duration is 20 $\mu$ sec

Frequency input	Variable reluctance (software configurable)
Input frequency	0 Hz - 25 kHz Note: maximum aggregate is 200 kHz, minimum detectable pulse duration is 20 $\mu$ sec
Switch-on level	Selectable as 2.2 V or adaptive
Switch-off level	Selectable as 0.0 V or 1.0 V

Analog input	0 - 5 V (absolute & ratiometric), 0 - 10 V, 0 - 32 V, 0 - 20 mA, thermistor (software configurable)
Resolution	12 bits
Accuracy	+/- 0.2 % FS (0-5 VDC mode), +/- 1 % FS (all other modes)
Short circuit protection	Integrated

Voltage input	0 - 5 V
Input frequency	1 kHz

Voltage input	0 - 10 V
Input frequency	1 kHz

Voltage input	0 - 32 V
Input frequency	1 kHz

Thermistor input	
Input resistance	22 kOhm pull-up
Sample frequency	1 kHz
Accuracy	+/-1%
Current input	0 - 20 mA
Input frequency	1 kHz

## Technical data

### Outputs

Digital output – 2A	High side
Max amperage	2A
Diagnostics	Open/short circuit protection

PWM output current feedback – 2A	High side (software configurable)
Max amperage	2A
Diagnostics	Open/short circuit protection
PWM frequency	.05 Hz – 2 kHz or 50 Hz – 2 kHz
Dither frequency	Configurable
Dither amplitude	Configurable
Control range	0.05 - 2A
Control resolution	1 mA
Fly back protection	Integrated
Duty cycle resolution	.01% @ 250 Hz

Digital output – 4A	Low/high side, H-bridge (software configurable)
Max amperage	4A
Diagnostics	Open/short circuit protection

PWM output current feedback – 4A	Low/high side, H-bridge (software configurable) in PWM mode, high side (software configurable) in current control mode
Max amperage	4A
Diagnostics	Open/short circuit protection
PWM frequency	50 - 500 Hz
Dither frequency	Configurable
Dither amplitude	Configurable
Control range	0.05 - 4A
Control resolution	1.5 mA
Fly back protection	Integrated
Duty cycle resolution	.01% @ 250 Hz

### Connections

Connector – 6 Pin	Deutsch Inc.
Model	DT04-6P
Contact surface	Nickel plated

Connector – 40 Pin	Deutsch Inc.
Model	DRC23-40PA
Contact surface	Nickel plated
Torque specification	25-28 in-lbs (2.82 - 3.16 N-m)

## Technical data

### Standards

---

Temperature environment	SAE J1455
Environmental	SAE J1455
Salt spray	J1455 Section 4.3.3
Vibration	J1455 Section 4.10.4.1
Drop	J1455 Section 4.11.3.1
Shock	J1455 Section 4.10.4
Conducted immunity	SAE J1113, EN 61326-1, 2004/108/EC
Radiated immunity	SAE J1113, EN 61326-1, 2004/108/EC
Conducted emissions	CISPR 25, EN 60945, 2004/108/EC
Radiated emission	CISPR 25, CISPR 11, EN60945

### Certifications

---

CE Mark

---

e-Mark

---

## Block diagram

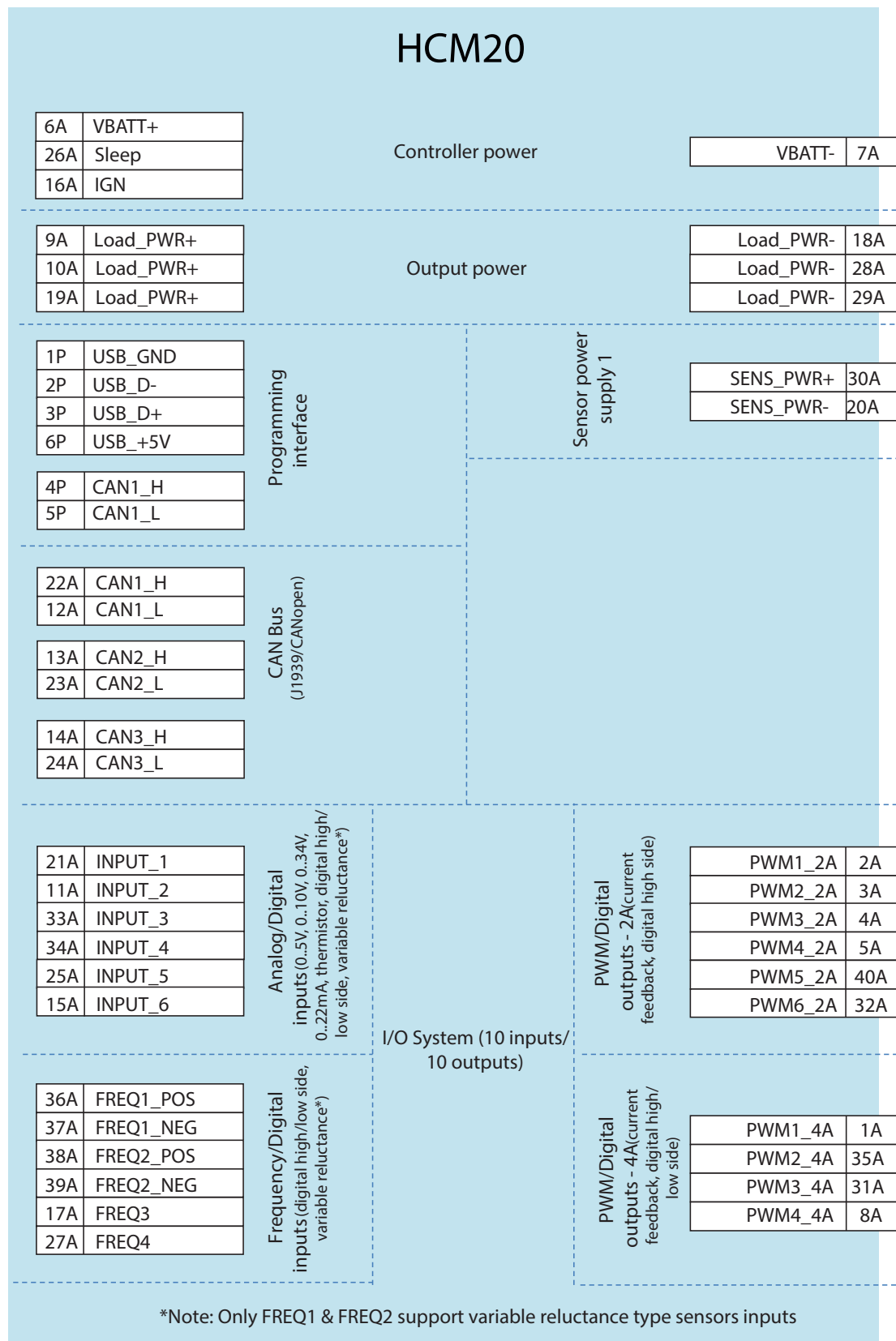

## Pin list

### Communications connector

Type	Deutsch	DT04-6P
Pin	Function	
1	Ground	
2	USB data low	
3	USB data high	
4	CAN 1 high	
5	CAN 1 low	
6	USB power 5V	

### Connector A

Type	Deutsch	DRC23-40PA
Pin	Function	
1	Output PWM1 4A	
2	Output PWM1 2A	
3	Output PWM2 2A	
4	Output PWM3 2A	
5	Output PWM4 2A	
6	System power positive	
7	System power negative	
8	Output PWM4 4A	
9	Load power positive	
10	Load power positive	
11	Input 2	
12	CAN 1 low	
13	CAN 2 high	
14	CAN 3 high	
15	Input 6	
16	Ignition	
17	Frequency 3	
18	Load power negative	
19	Load power positive	
20	Sensor power 1 negative	
21	Input 1	
22	CAN 1 high	
23	CAN 2 low	
24	CAN 3 low	
25	Input 5	
26	Sleep	
27	Frequency 4	
28	Load power negative	
29	Load power negative	
30	Sensor power 1 positive	
31	Output PWM3 4A	
32	Output PWM6 2A	
33	Input 3	
34	Input 4	
35	Output PWM2 4A	
36	Input frequency 1 positive	
37	Input frequency 1 negative	
38	Input frequency 2 positive	
39	Input frequency 2 negative	
40	Output PWM5 2A	

## Mounting diagram

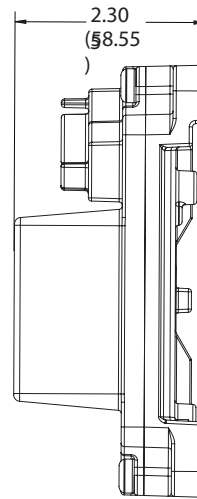
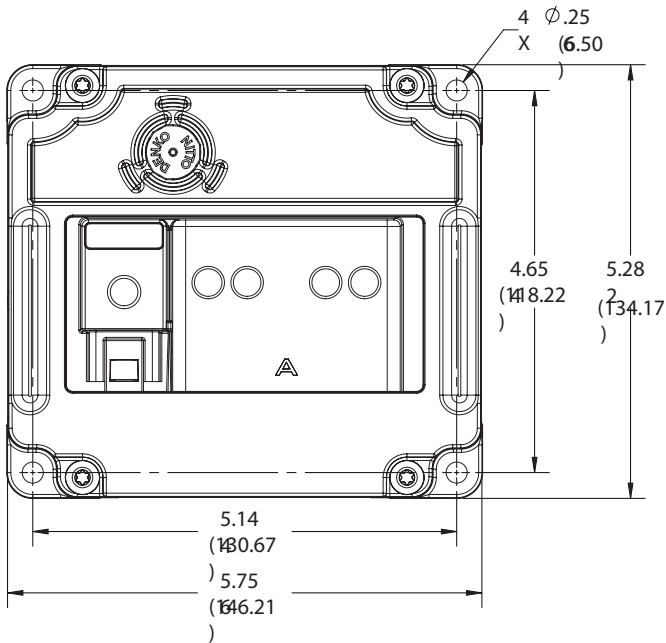

Deutsch Industrial,  
Connector Plug-DT04-6P  
Connector Plug-  
DRC23-40PA

