

# CONNECTOR AMPLIFIER FOR PROPORTIONAL VALVES (0-10VDC Input Version)

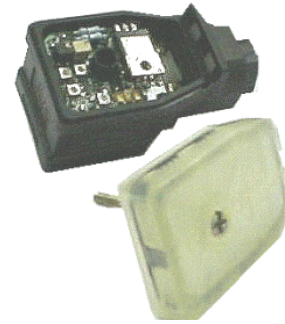

## Part No.: Connector Amplifier

CAPV-H-10V-x complete with cable CAPV-6C-yM

Where: x = maximum current output (2A, 1.2A or 800mA)  
y = cable length (2 meters is the standard length)

**Function:** The Connector Amplifier supplies a solenoid valve with current proportional to an input control (0-10VDC or 0-20mA).

## Features:

- Maximum current adjustment does not affect minimum current setting
- Adjustments accessible with a removable cover
- Broad range of supply voltages (9 to 28 VDC) with no degradation in performance
- Current sensing circuit maintains output current regardless of changes in input voltage and coil resistance
- Modern technology utilizing high frequency switching output (PWM)
- Energy efficient design (no heat sink is required)
- Simple control with 0-10VDC or 0-20mA signal inputs
- Options for maximum current output include 2A, 1.2A or 800mA
- Mates to a DIN 43650 plug on a cartridge or block style solenoid valve
- Electronic limiting circuit means no internal fuses
- Short circuit proof (in case of solenoid failure or miswiring)
- Reverse polarity protection
- 2 m cable, unterminated
- Can disconnect load while unit is powered ("Hot Swap")

**Application:** Accurate control of hydraulic and pneumatic proportional solenoid valves used in mobile construction equipment and industrial processes.

## 1.0 Introduction:

The User Guide for the Connector Amplifier describes the installation, set up adjustments and use of the unit with proportional solenoids.

## 1.1 Description:

The 0-10V Connector Amplifier simplifies control of proportional solenoids by supplying a current proportional to an input control (0-10V or 0-20mA). It accepts power supply voltages from 9 to 32VDC. This linear solenoid driver utilizes high frequency switching output (PWM) to provide a DC current output. The options for maximum current output include 2A, 1.2A or 800mA. A current sensing circuit maintains output current regardless of changes in input voltage and coil resistance. The user can adjust maximum and minimum current. Ramp time, dither frequency and amplitude can also be adjusted to match the application. The unit is available with a DIN 43650 connection to mount directly on the coil. Other versions are available with 4-20mA or 0-5V (including 0-20mA and 10K potentiometer) inputs. A remote mount version is housed in a rugged metal box.

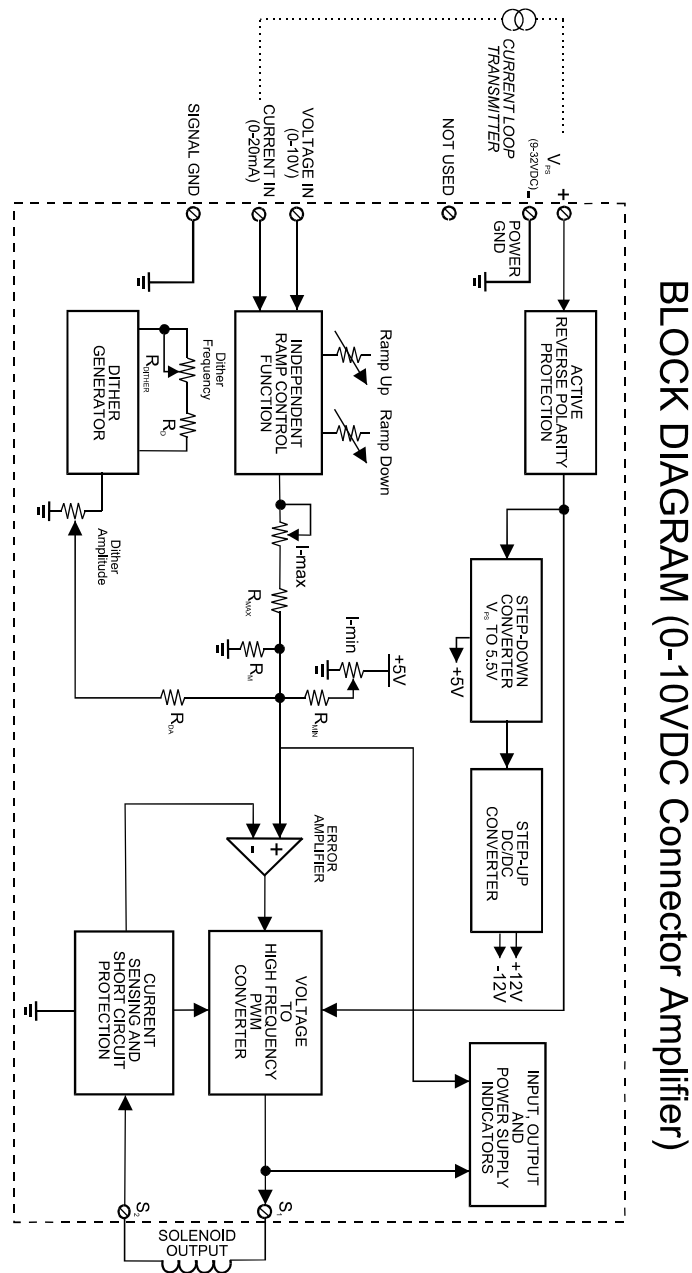

## 1.2 Technical Specifications:

All specifications typical at nominal input voltage and 25°C unless otherwise specified.

### General Specifications

Operating conditions	-40 to +85°C (-40 to 185°F)
Storage temperature	-50 to 125°C (-58 to 257°F)
Electromagnetic compatibility (EMC)	Emission EN 50081-2 Immunity EN 50082-2
Approvals	CE
Packaging, Cable and Electrical connections	<p><b>Housing:</b> Hirschmann GDME 2011 black housing (PA material, 94 V1), central screw M3 x 40, transparent cover, washer and o-ring, nitrile rubber gasket</p> <p>DIN 43650-A contact arrangement with 18 mm spacing (plug-style to mount on valve) Contacts: Sn, PA, 94V1</p> <p>Approvals: VDE, SEV, GL (A version for remote mounting is also available.)</p> <p><b>Cable:</b> 2 metre cable, 6 conductor, unterminated, 18 AWG For pin out, refer to Section 2.3. Manufacturer: Phoenix EDT Inc. P/N: D0518006-8 Conductors: Stranded, tin-plated copper Jacket: PVC Insulation: SR-PVC Cable Markings: UL AWM, CM, CSA AWM II A/B, CMG FT4</p>
Protection class	IP65 when correctly installed with lid, compression washer, o-ring and base gasket

### Dimensions in mm/inches (excluding cable)

Length L1	85.35mm	3.36"
L2	61.75mm	2.43"
L3	34.00mm	1.34"
Width = L3	34.00mm	1.34"
Height H1	38.00mm	1.49"

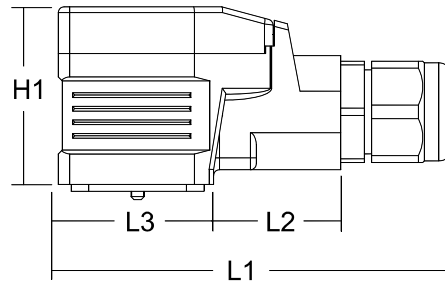

### Electrical Specifications

Operating voltage (power supply requirement)	9 to 28 VDC power supply range Accepts up to a maximum of 32 VDC
Control input signal options	0-10 VDC voltage signal or 0-20 mA current signal (4-20mA or 0-5VDC/0-20mA/10K potentiometer control input versions are also available.)
Input resistance	125K Ohms
Range of maximum output current	2A (or 1.2A or 800mA versions)
Solenoid resistance	$R_{coil} \leq (V_{power\ supply} - 1.5\ V) / I_{max}$

Note 1: Match power supply voltage with rating of solenoid coil. Operating the amplifier with a supply voltage lower than the solenoid rated voltage may result in reduced maximum current output.

Note 2: The coil should have no polarity or protection diodes for proper operation of the device.

Note 3: The maximum current output of the amplifier should not exceed the current rating of the solenoid coil.

## Adjustments

Minimum current setting	0 to 0.5 A (for 2 A output model) 0 to 0.3 A (for 1.2 A output model) 0 to 150 mA (for 600 mA output model)
Maximum current setting	0.6 to 2.0 A (for 2 A output model) 0.36 to 1.2 A (for 1.2 A output model) 180 to 600 mA (for 600 mA output model)
Current ramp time	0.01 - 5 sec. independent
Dither amplitude Current dither frequency	0 to 10% of rated maximum current 70 to 350 Hz ( $\pm 10\%$ of full scale)

Specifications are subject to change without notice.

## 2.0 Installation Procedures:

### 2.1 Precautions Against Leaks From The Environment

Ensure the transparent lid is firmly in place.

Ensure the brown rubber base gasket is in place, providing a seal between the Connector Amplifier and the valve.

The mounting screw with o-ring and washer in place should be flush with the top of the lid and fastened in place. Tighten the screw to make a firm connection to the valve with a Phillips #2 screwdriver.

### Housing (Side View)

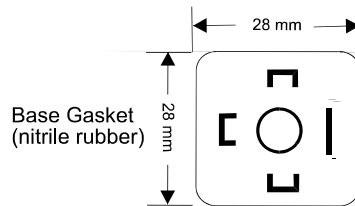
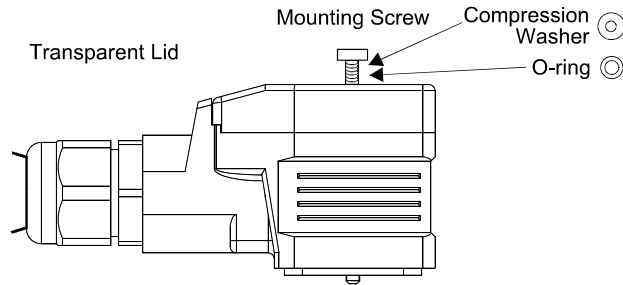

## 2.2 Necessary Equipment

- Connector Amplifier
- Cartridge or Block Proportional Solenoid Valve ready to accept a DIN 43650 plug
- Hydraulic power source and load circuit
- Power Supply (9 to 32 VDC)
- DC voltmeter (optional)
- Choice of Inputs: 0-10VDC voltage or 0-20mA current signal
- External fusing recommended (3A)

## 2.3 Installation Steps

- Supply voltage should be between 9 and 32 VDC. Excess voltage will damage the unit. Match the power supply voltage with the voltage rating of the solenoid coil. Operating the amplifier with a supply voltage lower than the solenoid rated voltage may result in reduced maximum current output.
- The maximum current output of the amplifier should not exceed the current rating of the solenoid coil.
- The coil should have no polarity or protection diodes for proper operation of the device.
- Do not install the unit near high voltage relays or other sources of electrical interference.
- Connect the power supply, signal input and valve solenoid as shown below and in Section 2.4. Put isolation sleeves on any unused wires for input signal.
- Set the input signal to the maximum level and confirm it is operating properly.

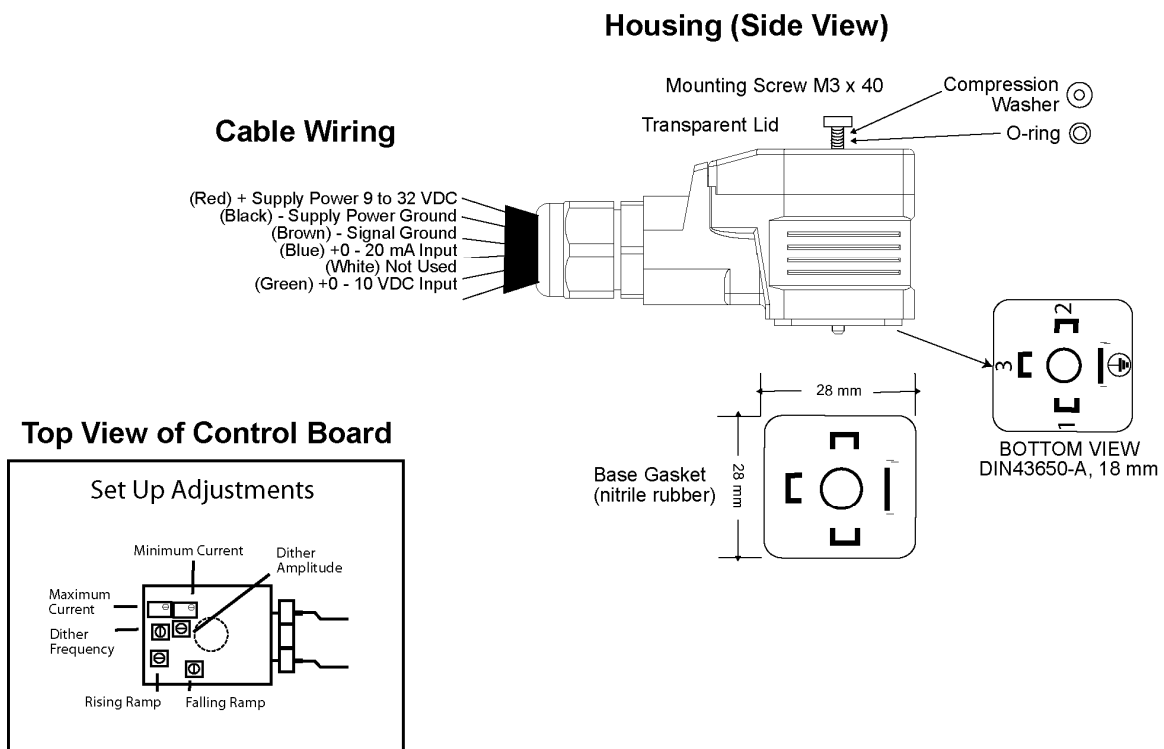

Connect the cable conductors to the power supply and input signal as follows.

For Either 0-20mA or 0-10VDC Control:

Turn ramp screws fully counterclockwise to eliminate ramping.

Use I-Min. screw to set up minimum speed with minimum control input.

Use I-Max. screw to set maximum speed with 100% of control input.

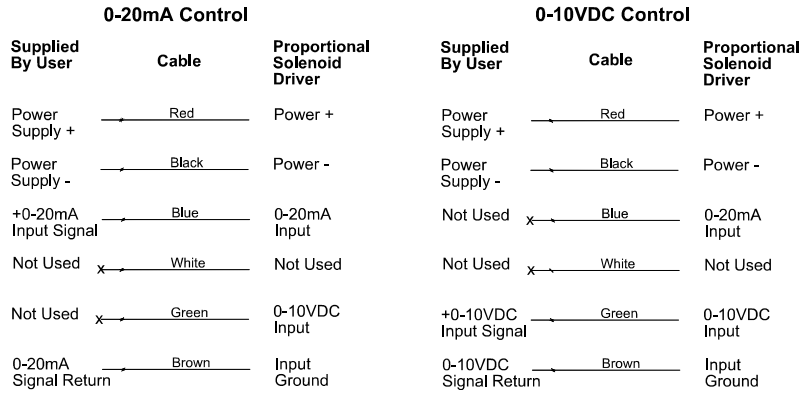

### 3.0 Set Up Adjustment Procedures:

The location of the trim pots for the set up adjustments are shown in Section 2.3.

**WARNING:** The operator must ensure that the operation of the valve within the full scale of the control function will not cause hazards, while performing set up adjustments to the Proportional Valve Controller/Amplifier.

#### 3.1 Preparation

Ensure that the Connector Amplifier is connected to an operating proportional valve.

Use a small screwdriver to loosen the mounting screw and remove the transparent lid.

The trim pots are adjusted with a jeweler's sized screwdriver (slotted 1.5).

#### 3.2 Interaction Between Maximum and Minimum Current Adjustments

Adjusting the maximum current ( $I_{max}$ ) does not affect the minimum current ( $I_{min}$ ) setting.

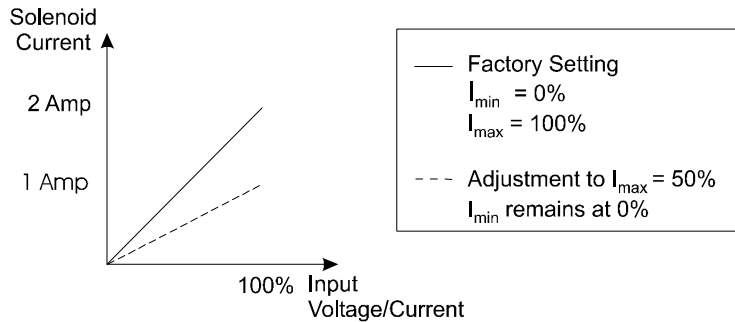

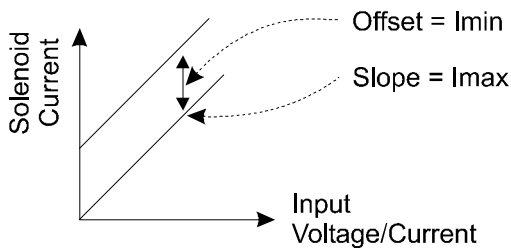

Adjusting the minimum current will shift the maximum current setting, as shown.

### 3.3 Connector Amplifier Settings

The following settings represent a typical set up for a voltage or current signal input operating scenario. Conditions will vary for other set up scenarios.  $I_{min}$  and  $I_{max}$  are multi-turn trim pots with a range of 10 turns. Use a slotted 1.5 screwdriver.

Trim Pot Adjustments	Range of Adjustment	Factory Setting
Zero - Minimum Current Setting ( $I_{min}$ )	0 to 0.5 A (for 2 A output model) 0 to 0.3 A (for 1.2 A output model) 0 to 150 mA (for 800 mA output model)	0% (CCW)
Span - Maximum Current Setting ( $I_{max}$ )	0.6 to 2.0 A* (for 2 A output model) 0.36 to 1.2 A (for 1.2 A output model) 300 to 800 mA (for 800 mA output model)	100% (CW)
Ramp Time (Rising and Falling Edge)	0.01 to 5 seconds independent	minimum (0.01 seconds) (CCW)**
Dither Level (Amplitude)	0 to 10% of rated maximum current	0% (CCW)
Dither Frequency	70 to 350 Hz ( $\pm 10\%$ )	minimum (CCW)

CW = clockwise, CCW = Counter clockwise

\*NOTE 1: Range of maximum output current is 2A (maximum output current = minimum current setting + maximum current setting)

\*\*NOTE 2: To eliminate ramping, turn the trim pots fully counterclockwise.

#### Setting the Minimum Current ( $I_{min}$ )

- **Set the minimum current before setting the maximum current.**
- Apply minimum input (0V or 0mA).
- The factory setting for the  $I_{min}$  trim pot is 0 or fully counterclockwise (CCW).
- If the desired minimum current is greater than 0, adjust the trim pot clockwise (CW) until the desired current is achieved.

The minimum current setting can be used to take into account the mechanical valve deadband and provide desired offsets from zero to allow full control within the functional range of the specific valve.

#### Setting the Maximum Current ( $I_{max}$ )

- Apply maximum control (10V or 20 mA).
- The factory setting for the  $I_{max}$  trim pot is 100% or fully CW.
- Turn the trim pot CCW to adjust the current setting downwards to the desired maximum.

The maximum current setting is adjusted to meet the customer's working pressure or flow range to the full scale signal input range. This provides maximum control for a specific application.

## Setting the Ramp Times

- The factory setting for ramp times is the minimum (0.01 seconds) or fully CCW.
- **If the ramp time settings are not needed, leave the setting at the minimum value.**
- To change the ramp times, adjust the trim pot CW to increase the time.
- Note that rising and falling ramp times are independent.

Ramp times are application dependent. They limit the rate of change or how fast the operation happens. Note that if the input signal is not applied long enough for the ramp time set, the desired solenoid current will not be reached.

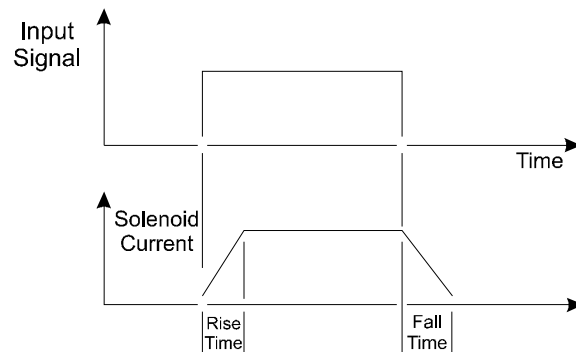

**Ramp Times**

## Setting the Dither Amplitude

- The factory setting for dither amplitude is 0% (CCW).
- To adjust dither amplitude, turn the trim pot CW until small changes in the input signal register an immediate response in the valve.
- Choose the smallest effective dither amplitude.

Dither amplitude is adjustable from 0 to 10% of the rated maximum current. Dither amplitude and frequency are dependent on the specific valve. The effects of static friction on the operation of the solenoid are reduced by the application of a small AC current. The hysteresis and repeatability of the valve are improved by this practice. The optimum dither amplitude is attained when small input signal changes register an immediate response in the valve (pressure or flow through the valve).

## Setting the Dither Frequency

- The factory setting for dither frequency is the minimum or 0% (CCW).
- To adjust dither frequency, turn the trim pot CW until the desired frequency is set.
- Refer to the proportional valve manufacturer's catalogue for the dither frequency rating of a particular valve.



## 4.0 Start Up Procedures:

A typical start up procedure is as follows:

1. Ensure the lid, compression washer, o-ring and base gasket are correctly in place (necessary for IP65 protection).
2. Ensure that no damage or injury can occur on the machine when the valve is operated.
3. Attach the Connector Amplifier to the load.
4. Switch on the power supply to the amplifier and apply a control signal.

Successful completion of these four steps means the Connector Amplifier and load are ready for normal use.

## 5.0 Operation:

The Connector Amplifier ensures a hydraulic proportional valve will function in a manner directly proportional to the control input. Accurate and repeatable operation is attained. Control of the hydraulic valve occurs with 0-10VDC or 0-20mA signal inputs.

The amplifier performs within the mechanical limits of the proportional valve. No maintenance of the unit is required.

## 6.0 Repair/Replacement:

The Connector Amplifier contains no serviceable components. Please do not disassemble the unit. **Tampering will void the product warranty.** The product will be replaced or repaired on a "return to factory" basis. For warranty terms refer to [www.axiomatic.com/service.html](http://www.axiomatic.com/service.html).

## 7.0 Ordering Part Number

**CAPV-H-10V-x complete with cable CAPV-6C-yM**

Where:           x = maximum current output (2A, 1.2A or 800mA)  
                      y = cable length (2 meters is the standard length)

Form: TD1108AX-10/03/18