

TECHNICAL DATASHEET #TDAX181000
TC/Analog Inputs to CAN Controller
 4 Thermocouple, 7 Analog & 3 Signal Inputs
 12 Vdc, 24 Vdc, 48 Vdc
 2 CAN (SAE J1939)

with Electronic Assistant®

P/N: AX181000

Description:

The TC/Analog Inputs to CAN Controller receives inputs from engine coolant, fuel and differential pressure sensors, engine temperature sensors, thermistors as well as thermocouples and is networked to a SAE J1939 based control system. Seven +5V references (10 mA) are provided to power the sensors. The 2 CAN ports are isolated from signal inputs and thermocouple inputs.



Using the Electronic Assistant® programming tool, the user can select the desired inputs from the following signal options.

- 4 Thermocouples (Type J, K or T)
- 7 Analog Signals (0-5 V, 0-10V, 0-20 mA, 4-20 mA)
- 3 Universal Signal Inputs (0-5V, 0-10V, Thermistor, 0-20 mA, 4-20 mA, PWM, Frequency or Counter, Discrete)

A rugged power supply interface accepts 12 Vdc, 24 Vdc or 48 Vdc nominal for battery powered machine applications. The unit carries an IP67 rating. It carries a CE mark. The rugged enclosure with four 12 pin Deutsch IPD connectors is suitable for diesel engine environments. It operates from -40 to 85°C (-40 to 185°F).

Applications:

- power gen set engine control systems
- oil and gas equipment automation
- marine engine applications
- off-highway machine automation

Ordering Part Numbers:

SAE J1939 Controller:

For baud rate, refer to the table below for the appropriate P/N.

Model P/N	Baud Rate	Standard Reference
AX181000	250 kBit/s	J1939/11, J1939/15.
AX181000-03	500 kBit/s	J1939/14. New standard

Electronic Assistant®: **AX070502**

Mating Plug Kit: **AX070123**

Technical Specifications:

Specifications are indicative and subject to change. Actual performance will vary depending on the application and operating conditions. Users should satisfy themselves that the product is suitable for use in the intended application. All our products carry a limited warranty against defects in material and workmanship. Please refer to our Warranty, Application Approvals/Limitations and Return Materials Process as described on www.axiomatic.com/service.html.

Block Diagram

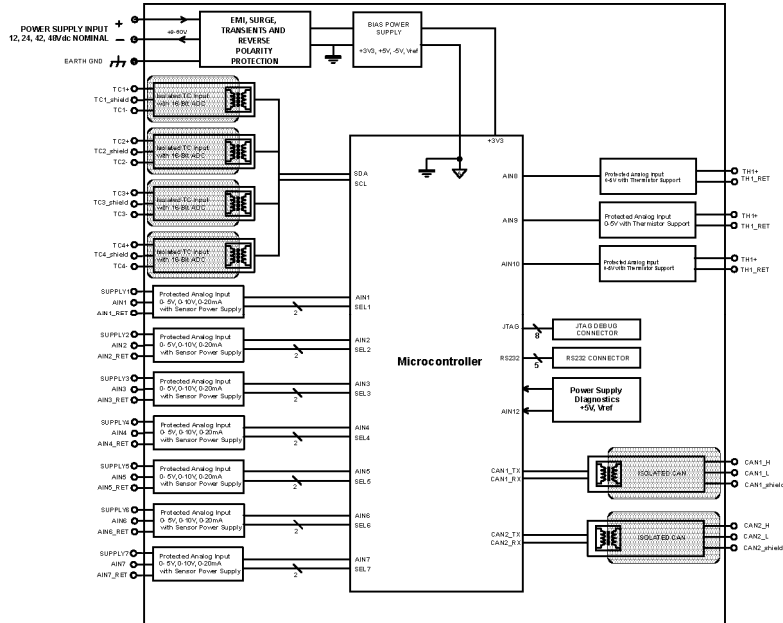

Control Logic

From the software perspective, the AX181000 consists of a set of internal functional blocks, which can be individually programmed using the Simulink® model to achieve the required system functionality. The functional blocks include: 1-7 analog inputs (voltage or current); 1-3 signal inputs; 1-4 Thermocouple inputs; 1-14 Can Transmit messages; and 1-14 DM1 messages.

The model operates with Simulink® for easy graphical programming in a model based simulation and development environment. The functional blocks have been readily implemented into the Simulink model. With the Simulink model it is possible for a customer to easily modify functional blocks to produce their own custom software. For example, input and CAN message connections can be altered, transfer functions can be added between inputs and CAN messages and initial values for functional block set points can be configured. The Axiomatic Hardware Interface Library (HWIL) is provided for this purpose. For simulating models using Axiomatic HWIL, licenses for Simulink® and Stateflow® are required. Code generation requires the Simulink Coder™ license in addition.

Inputs

Power Supply Input	12 Vdc, 24 Vdc or 48 Vdc nominal (9...60 Vdc power supply range)
Protection	Reverse polarity protection Overvoltage protection is up to 120 V.
Inputs	4 Thermocouple Inputs 7 Analog Signal Inputs (0-5 V, 0-10V, 0-20 mA, 4-20 mA) 3 Universal Signal Inputs (0-5V, 0-10V, Thermistor, 0-20 mA, 4-20 mA, PWM, Frequency or Counter, Discrete) User programmable (Refer to Table 1.0.) Inputs and Power are isolated from CAN.
Inputs Scan Rate	Each analog and universal input is scanned every 1 ms. A complete scan of all inputs is 10 ms. New measured values are ready every 10 ms. The 4 TC inputs new measured value is available every 400 ms.
Analog Grounds	10 are provided and they are common to each other.

Table 1.0 – Inputs – User Programmable Options																									
Thermocouple Inputs	Reads up to 4 Type J, K or T thermocouple inputs <ul style="list-style-type: none"> • Full channel to channel isolation and isolation from CAN line, other inputs and power supply • Cold junction compensation is provided. • Thermocouple input resolution is 0.1 °C. • Accuracy is +/-1 °C throughout the entire range of the thermocouple input. • 4 shield connections are provided. • The sample rate for the 4 Channels is 300 ms. 																								
Analog Input Functions	Voltage or Current Input																								
Voltage Input	0-5 V (Impedance 200 KOhm) 0-10V (Impedance 150 KOhm)																								
Current Input	0-20 mA (Impedance 125 Ohm) 4-20 mA (Impedance 125 Ohm)																								
Digital Input Functions	Discrete Input, PWM Input, Frequency Input																								
Digital Input Level	12V or 24V Threshold: Low <1.5 V High >3.5V																								
PWM Input	0 to 100% 100 Hz to 10 kHz Note: Universal Inputs 2 and 3 share a timer in Frequency and PWM mode, thus they should be set on same frequency range.																								
Frequency/RPM Input	0.5 Hz to 50 Hz; 10 Hz to 1 kHz; or 100 Hz to 10 kHz																								
Digital Input	Active High with pull-up (input 8 - 5kΩ, input 9 and input 10 – 1kΩ)																								
Input Accuracy	<table border="1"> <thead> <tr> <th>Input Type</th> <th>Input Range</th> <th>Accuracy</th> </tr> </thead> <tbody> <tr> <td rowspan="2">Voltage</td> <td>0-5V</td> <td>0.1%</td> </tr> <tr> <td>0-10V</td> <td>0.1%</td> </tr> <tr> <td rowspan="2">Current</td> <td>0(4)-20mA</td> <td>0.1%</td> </tr> <tr> <td>Frequency</td> <td>0.5Hz-50Hz</td> <td>0.2%</td> </tr> <tr> <td rowspan="2"></td> <td>10Hz-1kHz</td> <td>0.17%</td> </tr> <tr> <td>100Hz-10kHz</td> <td>0.17%</td> </tr> <tr> <td rowspan="2">PWM</td> <td>Low Frequency</td> <td>0.08%</td> </tr> <tr> <td>High Frequency</td> <td>0.41%</td> </tr> </tbody> </table> <p style="text-align: center;">Table 2.0 - Input accuracy</p>	Input Type	Input Range	Accuracy	Voltage	0-5V	0.1%	0-10V	0.1%	Current	0(4)-20mA	0.1%	Frequency	0.5Hz-50Hz	0.2%		10Hz-1kHz	0.17%	100Hz-10kHz	0.17%	PWM	Low Frequency	0.08%	High Frequency	0.41%
Input Type	Input Range	Accuracy																							
Voltage	0-5V	0.1%																							
	0-10V	0.1%																							
Current	0(4)-20mA	0.1%																							
	Frequency	0.5Hz-50Hz	0.2%																						
	10Hz-1kHz	0.17%																							
	100Hz-10kHz	0.17%																							
PWM	Low Frequency	0.08%																							
	High Frequency	0.41%																							
Input Resolution	12-bit																								

Outputs

CAN bus	SAE J1939
Reference Voltages	7 provided +5V +/- 0.5% (10 mA)

General Specifications

Microprocessor	STM32F205 32-bit, 512 kByte flash memory
Typical Quiescent Current	84 mA@12Vdc; 52 mA@24Vdc
Response Time	3 mSec.
Control Logic	Standard embedded software is provided.
Communications	2 Isolated CAN ports (SAE J1939) (CANopen® on request) 300 Vrms
Baud Rates	AX181000: 250 kbps AX181000-03: 500 kbps

User Interface	<p>The Electronic Assistant®, P/N: AX070502, for <i>Windows</i> operating systems comes with a royalty-free license for use on multiple computers. It includes an Axiomatic USB-CAN converter to link the device's CAN port to a <i>Windows</i>-based PC.</p> <p>The setpoints can be viewed and programmed using the standard J1939 memory access protocol through the CAN port and the PC-based Axiomatic Electronic Assistant®. The EA can store all setpoints in one setpoint file and then flash them into the unit in one operation. The setpoint file is created and stored on disk using a command <i>Save Setpoint File</i> from the EA menu or toolbar. The user then can open the setpoint file, view or print it and flash the setpoint file into the controller.</p>
Operating Conditions	-40 to 85 °C (-40 to 185 °F)
Storage Temperature	-55 to 125 °C (-67 to 257°F)
Protection	IP67
Compliance	CE mark
Weight	1.30 lbs. (0.59 kg)
Packaging	High Temperature Nylon housing, Deutsch IPD P/N: EEC-5X650B 4.03 x 4.25 x 1.68 inches 102.44 x 107.96 x 42.67 mm (L x W x H including integral connector) Refer to the dimensional drawing.
Electrical Connections	<p>48 pin Deutsch IPD connector P/N: DT13-48PABCD-R015</p> <p>Mates with: Deutsch IPD P/N's DT06-12SA Plug, DT 12 Way A Key DT06-12SB Plug, DT 12 Way B Key DT06-12SC Plug, DT 12 Way C Key DT06-12SD Plug, DT 12 Way D Key</p> <p>For the electrical pin out, refer to Table 3.0.</p>
Network Termination	It is necessary to terminate the network with external termination resistors. The resistors are 120 Ohm, 0.25W minimum, metal film or similar type. They should be placed between CAN_H and CAN_L terminals at both ends of the network.

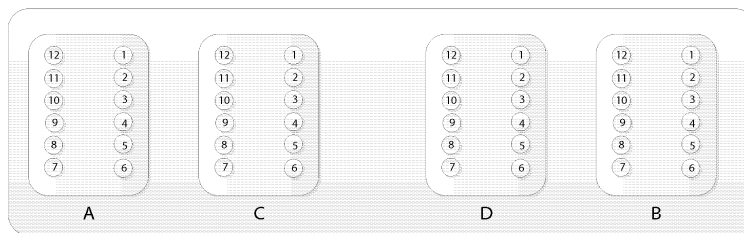
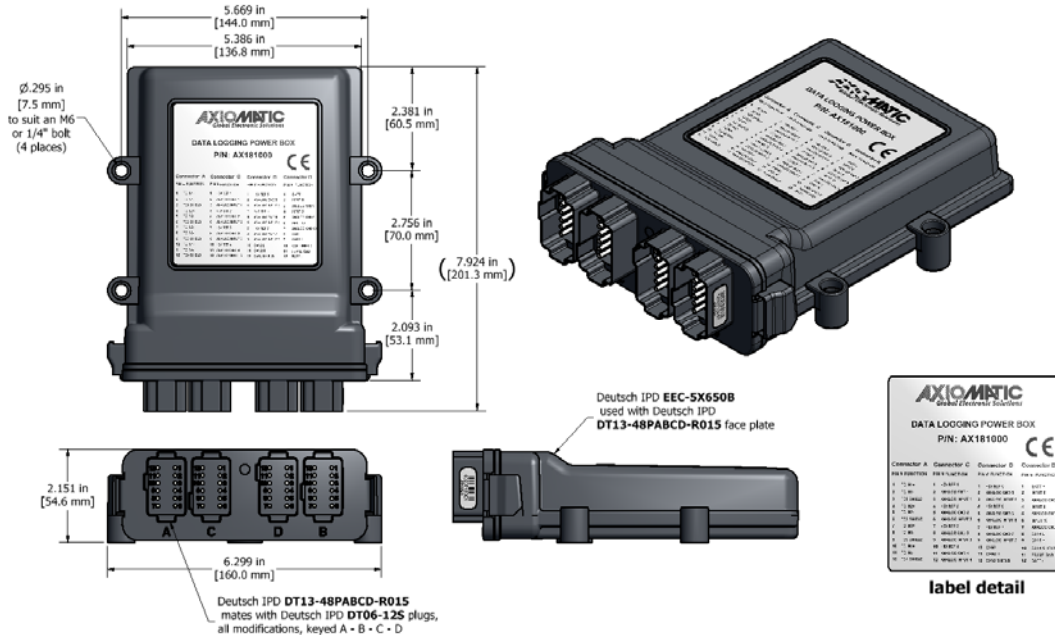

Table 3.0 - Electrical Pin Out

Connector A		Connector C		Connector D		Connector B	
Pin #	Function	Pin #	Function	Pin #	Function	Pin #	Function
1	TC IN1+	1	+5Vref. 1	1	+5Vref. 5	1	Batt+
2	TC IN1-	2	Analog GND 1	2	Analog GND 5	2	Input 8
3	TC1 Shield	3	Analog Input 1	3	Analog Input 5	3	Analog GND 8
4	TC IN2+	4	+5Vref. 2	4	+5Vref. 6	4	Input 9
5	TC IN2-	5	Analog GND 2	5	Analog GND 6	5	Analog GND 9
6	TC2 Shield	6	Analog Input 2	6	Analog Input 6	6	Input 10
7	TC IN3+	7	+5Vref. 3	7	+5Vref. 7	7	Analog GND 10
8	TC IN3-	8	Analog GND 3	8	Analog GND 7	8	CAN1 L
9	TC3 Shield	9	Analog Input 3	9	Analog Input 7	9	CAN1 H
10	TC IN4+	10	+5Vref. 4	10	CAN2 L	10	CAN1 Shield
11	TC IN4-	11	Analog GND 4	11	CAN2 H	11	Frame GND
12	TC4 Shield	12	Analog Input 4	12	CAN2 Shield	12	Batt-

Dimensional Drawing



Notes: Electronic Assistant® is a registered US trademark of Axiomatic Technologies Corporation.
 Mathworks®, Simulink®, Stateflow® and MATLAB® are registered trademarks of The MathWorks, Inc.
 Simulink Coder™ is a trademark of the The Mathworks, Inc.

Form: TDAX181000-04/28/17