

ECONOMY DUAL CHANNEL UNIVERSAL SIGNAL CONVERTER

2 Analog, Resistive, Digital, Frequency (RPM) or PWM Signal Inputs

2 Analog, Digital, Frequency or PWM Signal Outputs

+5V reference (50 mA)

Isolated CAN (SAE J1939)

Developed with Simulink®

with Electronic Assistant®

P/N: AX130520

Description: The dual channel universal signal converter accepts two voltage, current, resistive, frequency, RPM, PWM or digital control signal inputs and converts them into two signal outputs (analog voltage, analog current or digital signal). The control can be networked to a SAE J1939 networked engine control system.

The unit has isolation between power and CAN.

Using the Electronic Assistant® programming tool, the user can select the desired inputs from the following signal options.

- 0-5 V, 0-10 Vdc
- 4-20 mA, 0-20 mA or 0-200 mA
- 20 Ohms to 250 kOhm
- Frequency/RPM
- PWM
- or Digital (Active High or Active Low)

A +5V, 50 mA reference is available to power a sensor input.

The outputs can also be programmed as 0-5 Vdc, 0-10 Vdc, 0-20 mA, 4-20 mA, Frequency, RPM, PWM or digital on/off signals.

A rugged power supply interface accepts 12 Vdc or 24 Vdc nominal for battery powered machine applications. The unit carries an IP67 rating. The rugged enclosure with 12 pin Deutsch IPD connector is suitable for harsh environments. It operates from -40 to 85°C (-40 to 185°F).

Applications:

- power gen set engine control systems
- oil and gas equipment automation
- off-highway machine automation

Ordering Part Numbers:

Dual Channel Universal Signal Converter, SAE J1939 250 kbps: **AX130520**

Dual Channel Universal Signal Converter, SAE J1939 500 kbps: **AX130520-01**

Dual Channel Universal Signal Converter, SAE J1939 1 Mbps: **AX130520-02**

Accessories:

Mating Plug Kit: **PL-DTM06-12SA**

Electronic Assistant®: **AX070502**



Block Diagram

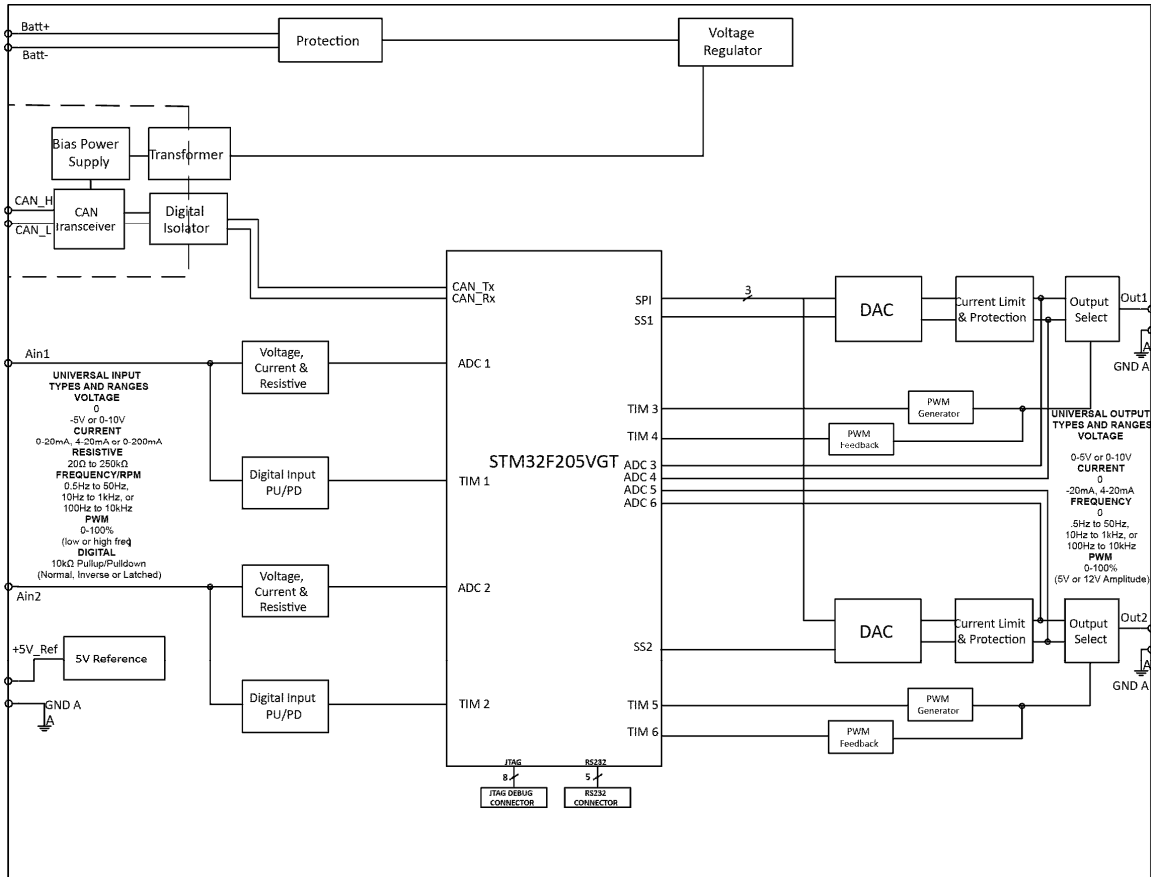

The controller belongs to a family of Axiomatic smart controllers with programmable internal architecture. This provides users with flexibility, allowing them to build their own custom controller with a required functionality from a set of predefined internal functional blocks using the PC-based Axiomatic Electronic Assistant® software tool. Application programming is performed through the CAN interface, without disconnecting the controller from the user's system.

Technical Specifications:

Specifications are indicative and subject to change. Actual performance will vary depending on the application and operating conditions. Users should satisfy themselves that the product is suitable for use in the intended application. All our products carry a limited warranty against defects in material and workmanship. Please refer to our Warranty, Application Approvals/Limitations and Return Materials Process as described on www.axiomatic.com/service.html.

Power Supply

Power Supply Input	12 Vdc or 24 Vdc nominal 9...36 Vdc power supply range Shutdown voltage is 8.0 Vdc.
Protection	Reverse polarity protection Overvoltage protection is up to 45 V.

Inputs

Inputs	2 Universal Signal Inputs User programmable as Voltage, Current, Resistive, Frequency, RPM, PWM or Digital signal inputs types. Refer to Table 1.0.
--------	---

Table 1.0 –User Programmable Universal Inputs																																													
Analog & Digital Input Functions	Voltage Input, Current Input, Resistive Input or Digital Input 12 bit Analog to Digital																																												
Voltage Input	0-5 V (Impedance 110 kΩ) 0-10 V (Impedance 130 kΩ))																																												
Current Input	0-200 mA (Impedance 5 Ω); 1V max. 0-20 mA (Impedance 249 Ω) 4-20 mA (Impedance 249 Ω)																																												
Resistive	20 Ohms to 250 kOhms Self-calibrating																																												
Digital Input Level	Accepts 5 V TTL Accepts up to Vps Threshold: Low <1 V High >2.2 V Normal, Inverse or Latched 10kΩ Pull up/Pull down																																												
Digital Input	Active High or Active Low with 10 kOhm pull-up or pull-down																																												
Timer Input Functions	PWM Input, Frequency Input, RPM Input 15-bit Timer																																												
PWM Input	100 Hz to 10 kHz 0 to 100% D.C. (Impedance 1 MΩ)																																												
Frequency/RPM Input	0.5 Hz to 50 Hz; 10 Hz to 1 kHz; or 100 Hz to 10 kHz 1 to 99% D.C.																																												
Maximum and Minimum Ratings	<table border="1"> <thead> <tr> <th>Characteristic</th> <th>Min</th> <th>Max</th> <th>Units</th> </tr> </thead> <tbody> <tr> <td>Power Supply</td> <td>9</td> <td>36</td> <td>V dc</td> </tr> <tr> <td>Voltage Input</td> <td>0</td> <td>36</td> <td>V dc</td> </tr> <tr> <td>Current Input 0(4)-20 mA</td> <td>0</td> <td>12</td> <td>Vdc</td> </tr> <tr> <td>Current Input 0-200 mA</td> <td>0</td> <td>1V</td> <td>Vdc</td> </tr> <tr> <td>Resistive Input</td> <td>20</td> <td>250 000</td> <td>Ω</td> </tr> <tr> <td>Digital Input</td> <td>0</td> <td>36</td> <td>Vdc</td> </tr> <tr> <td>PWM Duty Cycle</td> <td>0</td> <td>100</td> <td>%</td> </tr> <tr> <td>PWM Frequency</td> <td>100</td> <td>10 000</td> <td>Hz</td> </tr> <tr> <td>PWM Voltage pk - pk</td> <td>0</td> <td>36</td> <td>V dc</td> </tr> <tr> <td>RPM Frequency</td> <td>0.5</td> <td>10 000</td> <td>Hz</td> </tr> </tbody> </table>	Characteristic	Min	Max	Units	Power Supply	9	36	V dc	Voltage Input	0	36	V dc	Current Input 0(4)-20 mA	0	12	Vdc	Current Input 0-200 mA	0	1V	Vdc	Resistive Input	20	250 000	Ω	Digital Input	0	36	Vdc	PWM Duty Cycle	0	100	%	PWM Frequency	100	10 000	Hz	PWM Voltage pk - pk	0	36	V dc	RPM Frequency	0.5	10 000	Hz
Characteristic	Min	Max	Units																																										
Power Supply	9	36	V dc																																										
Voltage Input	0	36	V dc																																										
Current Input 0(4)-20 mA	0	12	Vdc																																										
Current Input 0-200 mA	0	1V	Vdc																																										
Resistive Input	20	250 000	Ω																																										
Digital Input	0	36	Vdc																																										
PWM Duty Cycle	0	100	%																																										
PWM Frequency	100	10 000	Hz																																										
PWM Voltage pk - pk	0	36	V dc																																										
RPM Frequency	0.5	10 000	Hz																																										

Input Grounds	1 provided																																							
Protection	All inputs are protected against short to GND. All inputs, except current inputs, are protected against shorts to Nominal Vps (36Vdc).																																							
Input Accuracy and Resolution	<table border="1"> <thead> <tr> <th>Input Type</th> <th>Input Range</th> <th>Accuracy</th> <th>Resolution</th> </tr> </thead> <tbody> <tr> <td rowspan="2">Voltage</td> <td>0-5V</td> <td>+/-1%</td> <td>1 mV</td> </tr> <tr> <td>0-10V</td> <td>+/-1%</td> <td>1 mV</td> </tr> <tr> <td rowspan="2">Current</td> <td>0(4)-20mA</td> <td>+/-2%</td> <td>1 μA</td> </tr> <tr> <td>0-200mA</td> <td>+/-2%</td> <td>1 μA</td> </tr> <tr> <td>Resistive</td> <td>20-250kΩ</td> <td>+/-1%</td> <td>1 Ω for lower ranges 1 kΩ for higher ranges</td> </tr> <tr> <td rowspan="3">Frequency</td> <td>0.5Hz-50Hz</td> <td>+/-1%</td> <td>0.01 Hz</td> </tr> <tr> <td>10Hz-1kHz</td> <td>+/-1%</td> <td>0.1 Hz</td> </tr> <tr> <td>100Hz-10kHz</td> <td>+/-1%</td> <td>1 Hz</td> </tr> <tr> <td rowspan="2">PWM</td> <td>Low Frequency</td> <td>+/-1%</td> <td>0.01%</td> </tr> <tr> <td>High Frequency</td> <td>+/-1%</td> <td>0.01%</td> </tr> </tbody> </table>	Input Type	Input Range	Accuracy	Resolution	Voltage	0-5V	+/-1%	1 mV	0-10V	+/-1%	1 mV	Current	0(4)-20mA	+/-2%	1 μ A	0-200mA	+/-2%	1 μ A	Resistive	20-250k Ω	+/-1%	1 Ω for lower ranges 1 k Ω for higher ranges	Frequency	0.5Hz-50Hz	+/-1%	0.01 Hz	10Hz-1kHz	+/-1%	0.1 Hz	100Hz-10kHz	+/-1%	1 Hz	PWM	Low Frequency	+/-1%	0.01%	High Frequency	+/-1%	0.01%
Input Type	Input Range	Accuracy	Resolution																																					
Voltage	0-5V	+/-1%	1 mV																																					
	0-10V	+/-1%	1 mV																																					
Current	0(4)-20mA	+/-2%	1 μ A																																					
	0-200mA	+/-2%	1 μ A																																					
Resistive	20-250k Ω	+/-1%	1 Ω for lower ranges 1 k Ω for higher ranges																																					
Frequency	0.5Hz-50Hz	+/-1%	0.01 Hz																																					
	10Hz-1kHz	+/-1%	0.1 Hz																																					
	100Hz-10kHz	+/-1%	1 Hz																																					
PWM	Low Frequency	+/-1%	0.01%																																					
	High Frequency	+/-1%	0.01%																																					

Outputs

Outputs	<p>2 Signal Outputs Voltage, Current or Digital The outputs are user selectable as follows. Refer to Table 2.0.</p> <table border="1"> <thead> <tr> <th colspan="2">Table 2.0: Programmable Outputs</th> </tr> </thead> <tbody> <tr> <td>Analog Voltage or Current Outputs:</td> <td> <p><u>Voltage Output:</u> 0-5 Vdc or 0-10 Vdc Maximum load is 50 mA.</p> <p><u>Current Output:</u> 0-20 mA or 4-20 mA Maximum load resistance is < 500 Ohms. Compliance Voltage is 10V.</p> </td> </tr> <tr> <td>PWM, Frequency or Mixed PWM/Frequency Output:</td> <td> <p>0.1 Hz to 50 kHz 0-100% D.C. 5 V or 12 V Amplitude Push pull output Maximum load is 50 mA. Over-current protection (50 mA)</p> </td> </tr> <tr> <td>Digital Output:</td> <td> <p>Digital Level Digital ON/OFF 5 V or 12 V Amplitude Maximum load is 50 mA.</p> </td> </tr> </tbody> </table>	Table 2.0: Programmable Outputs		Analog Voltage or Current Outputs:	<p><u>Voltage Output:</u> 0-5 Vdc or 0-10 Vdc Maximum load is 50 mA.</p> <p><u>Current Output:</u> 0-20 mA or 4-20 mA Maximum load resistance is < 500 Ohms. Compliance Voltage is 10V.</p>	PWM, Frequency or Mixed PWM/Frequency Output:	<p>0.1 Hz to 50 kHz 0-100% D.C. 5 V or 12 V Amplitude Push pull output Maximum load is 50 mA. Over-current protection (50 mA)</p>	Digital Output:	<p>Digital Level Digital ON/OFF 5 V or 12 V Amplitude Maximum load is 50 mA.</p>																						
Table 2.0: Programmable Outputs																															
Analog Voltage or Current Outputs:	<p><u>Voltage Output:</u> 0-5 Vdc or 0-10 Vdc Maximum load is 50 mA.</p> <p><u>Current Output:</u> 0-20 mA or 4-20 mA Maximum load resistance is < 500 Ohms. Compliance Voltage is 10V.</p>																														
PWM, Frequency or Mixed PWM/Frequency Output:	<p>0.1 Hz to 50 kHz 0-100% D.C. 5 V or 12 V Amplitude Push pull output Maximum load is 50 mA. Over-current protection (50 mA)</p>																														
Digital Output:	<p>Digital Level Digital ON/OFF 5 V or 12 V Amplitude Maximum load is 50 mA.</p>																														
Output Accuracy and Resolution	<table border="1"> <thead> <tr> <th>Output Type</th> <th>Output Range</th> <th>Output Accuracy</th> <th>Output Resolution</th> </tr> </thead> <tbody> <tr> <td rowspan="2">Voltage</td> <td>0-5V</td> <td>+/- 1%</td> <td>1 mV</td> </tr> <tr> <td>0-10V</td> <td>+/- 1%</td> <td>1 mV</td> </tr> <tr> <td>Current</td> <td>0(4)-20mA</td> <td>+/- 1%</td> <td>0.5 μA</td> </tr> <tr> <td>Digital</td> <td>On/Off</td> <td>+/- 1%</td> <td>N/A</td> </tr> <tr> <td>Frequency</td> <td>0.1Hz-50kHz</td> <td>+/- 1%</td> <td>TBD</td> </tr> <tr> <td rowspan="2">PWM</td> <td>Low Frequency</td> <td>+/- 1%</td> <td>TBD</td> </tr> <tr> <td>High Frequency</td> <td>+/- 1%</td> <td>TBD</td> </tr> </tbody> </table>	Output Type	Output Range	Output Accuracy	Output Resolution	Voltage	0-5V	+/- 1%	1 mV	0-10V	+/- 1%	1 mV	Current	0(4)-20mA	+/- 1%	0.5 μ A	Digital	On/Off	+/- 1%	N/A	Frequency	0.1Hz-50kHz	+/- 1%	TBD	PWM	Low Frequency	+/- 1%	TBD	High Frequency	+/- 1%	TBD
Output Type	Output Range	Output Accuracy	Output Resolution																												
Voltage	0-5V	+/- 1%	1 mV																												
	0-10V	+/- 1%	1 mV																												
Current	0(4)-20mA	+/- 1%	0.5 μ A																												
Digital	On/Off	+/- 1%	N/A																												
Frequency	0.1Hz-50kHz	+/- 1%	TBD																												
PWM	Low Frequency	+/- 1%	TBD																												
	High Frequency	+/- 1%	TBD																												
Voltage Reference	+5V, 50 mA Ground is shared with Input Grounds.																														
Protection for Output Terminals	Fully protected against short circuit to output ground. Unit will fail safe in the case of a short circuit condition, self-recovering when the short is removed.																														

General Specifications

Microprocessor	STM32F205VGT
Isolation	300 Vrms Power and CAN are isolated from each other.
Typical Quiescent Current	60 mA @ 12Vdc typical; 34 mA @ 24Vdc typical
Response Time	28.4 milliseconds
Control Logic	Standard embedded software is provided. (Application-specific control logic or a set point file is available on request.)

Simulink®	Model AX130520 was developed using Simulink®. Simulink® is a model-based design tool from Mathworks®.
Communications	1 Isolated CAN port (SAE J1939) (CANopen® on request) Models: AX130520 – 250 kbps baud rate AX130520-01 – 500 kbps baud rate AX130520-02 – 1 Mbps baud rate
Network Termination	It is necessary to terminate the network with external termination resistors. The resistors are 120 Ohm, 0.25W minimum, metal film or similar type. They should be placed between CAN_H and CAN_L terminals at both ends of the network.
User Interface	The AX130520 setpoints can be viewed and programmed using the standard J1939 memory access protocol through the CAN port and the PC-based Axiomatic Electronic Assistant®. The EA can store all setpoints in one setpoint file and then flash them into the unit in one operation. The setpoint file is created and stored on disk using a command <i>Save Setpoint File</i> from the EA menu or toolbar. The user then can open the setpoint file, view or print it and flash the setpoint file into the AX130520. The Electronic Assistant®, P/N: AX070502 , for <i>Windows</i> operating systems comes with a royalty-free license for use on multiple computers. It includes an Axiomatic USB-CAN converter to link the device's CAN port to a <i>Windows</i> -based PC.
Operating Conditions	-40 to 85 °C (-40 to 185 °F)
Storage Temperature	-55 to 125 °C (-67 to 257°F)
Protection	IP67
Vibration	MIL-STD-202G, Test 204D and 214A (Sine and Random) 10 g peak (Sine) 7.86 Grms peak (Random)
Shock	MIL-STD-202G, Test 213B 50g
Weight	0.55 lb. (0.249 kg)
Enclosure	High Temperature Nylon housing - Deutsch IPD PCB Enclosure (EEC-325X4B) 4.62 x 5.24 x 1.43 inches 117.42 x 133.09 x 36.36 mm (W x L x H excluding mating plugs) Refer to the dimensional drawing.
Installation	For mounting information, refer to the dimensional drawing. Mounting holes sized for ¼ inch or M6 bolts. The bolt length will be determined by the end-user's mounting plate thickness. The mounting flange of the controller is 0.63 inches (16 mm) thick. If the module is mounted without an enclosure, it should be mounted vertically with connectors facing left and right to reduce likelihood of moisture entry. The CAN wiring is considered intrinsically safe. The power wires are not considered intrinsically safe and so in hazardous locations, they need to be located in conduit or conduit trays at all times. The module must be mounted in an enclosure in hazardous locations for this purpose. No wire or cable harness should exceed 30 meters in length. The power input wiring should be limited to 10 meters. All field wiring should be suitable for the operating temperature range. Install the unit with appropriate space available for servicing and for adequate wire harness access (6 inches or 15 cm) and strain relief (12 inches or 30 cm).

Dimensional Drawing

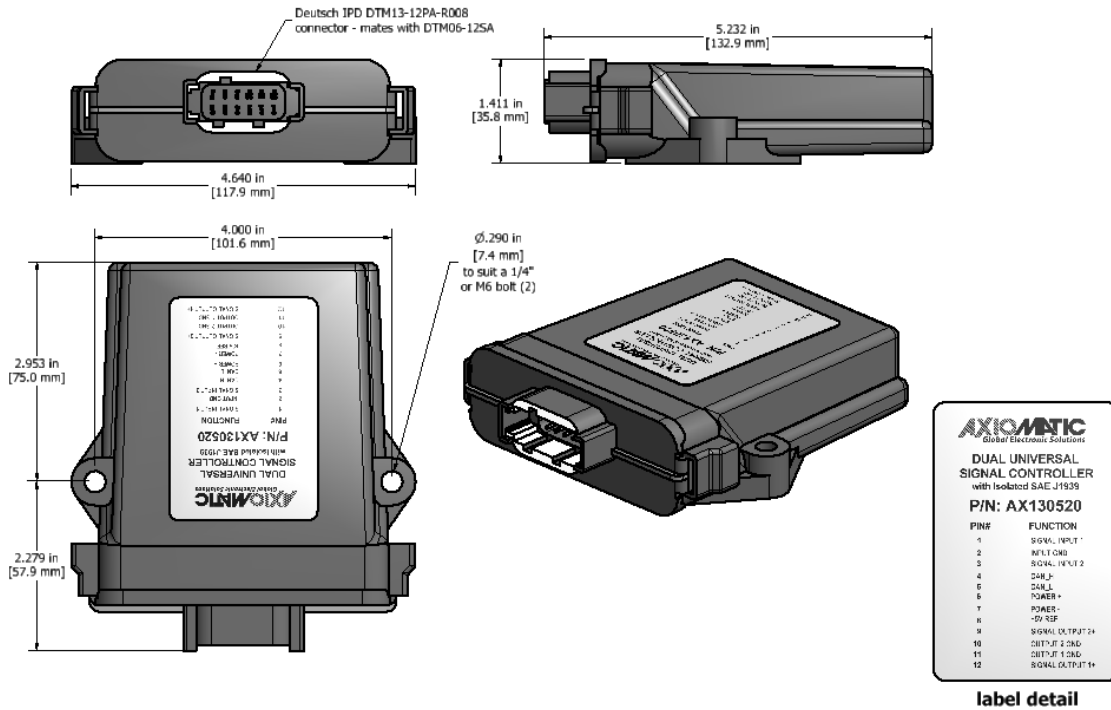

AXIOMATIC Global Electronic Solutions	
DUAL UNIVERSAL SIGNAL CONTROLLER with Isolated SAE J1939	
P/N: AX130520	
PIN#	FUNCTION
1	SIGNAL INPUT 1
2	INPUT GND
3	SIGNAL INPUT 2
4	CAN_H
5	CAN_L
6	POWER +
7	POWER -
8	+5V REF
9	SIGNAL OUTPUT 2+
10	OUTPUT GND 2
11	OUTPUT GND 1
12	SIGNAL OUTPUT 1+

label detail

Electrical Connections	<p>Deutsch DTM series 12 pin receptacle (P/N: DTM13-12PA-R008)</p> <p>20 AWG wire is recommended for use with contacts 0462-201-20141.</p> <p>Mating plug KIT: Available from Axiomatic as p/n: PL-DTM06-12SA. It is comprised of the following Deutsch IPD parts: plug (DTM06-12SA); wedgelock (WM12S); and 12 contacts (0462-201-20141) as well as 6 sealing plugs (0413-204-2005).</p>																									
	<table border="1"> <thead> <tr> <th>Pin #</th> <th>Description</th> </tr> </thead> <tbody> <tr> <td>1</td> <td>Analog/Digital Input 1</td> </tr> <tr> <td>2</td> <td>Input GND</td> </tr> <tr> <td>3</td> <td>Analog/Digital Input 2</td> </tr> <tr> <td>4</td> <td>CAN_H</td> </tr> <tr> <td>5</td> <td>CAN_L</td> </tr> <tr> <td>6</td> <td>Power +</td> </tr> <tr> <td>7</td> <td>Power -</td> </tr> <tr> <td>8</td> <td>+5V Reference</td> </tr> <tr> <td>9</td> <td>Analog/Digital Output 2+</td> </tr> <tr> <td>10</td> <td>Output GND 2</td> </tr> <tr> <td>11</td> <td>Output GND 1</td> </tr> <tr> <td>12</td> <td>Analog/Digital Output 1+</td> </tr> </tbody> </table>	Pin #	Description	1	Analog/Digital Input 1	2	Input GND	3	Analog/Digital Input 2	4	CAN_H	5	CAN_L	6	Power +	7	Power -	8	+5V Reference	9	Analog/Digital Output 2+	10	Output GND 2	11	Output GND 1	12
Pin #	Description																									
1	Analog/Digital Input 1																									
2	Input GND																									
3	Analog/Digital Input 2																									
4	CAN_H																									
5	CAN_L																									
6	Power +																									
7	Power -																									
8	+5V Reference																									
9	Analog/Digital Output 2+																									
10	Output GND 2																									
11	Output GND 1																									
12	Analog/Digital Output 1+																									

CANopen® is a registered community trade mark of CAN in Automation e.V.
 Electronic Assistant® is a registered U.S. trade mark of Axiomatic Technologies Corporation.
 Simulink® is a registered trademark of The Mathworks, Inc.

Form: TDAX130520-11/24/17