

Triaxial Inclinometer

SAE J1939 or CANopen
2 M12 Connector(s), IP67
with Electronic Assistant®

P/N: AX06080X

Features:

- Reliable, real-time, accurate and stable slope angle data
- MEMS-based accelerometer measures angle with respect to gravity
- Measures pitch and roll inclination angles in a full ± 180 degree orientation range
- Outputs gravity angle and accelerations in 3 orthogonal directions
- SAE J1939
- 12V, 24Vdc nominal power supply
- Aluminum enclosure, 2 round 5-pin A-coded M12 connectors, gasket
- IP67 protection
- Configurable using the **Electronic Assistant®**

Applications:

- Level, tilt, pitch and acceleration monitoring in agricultural, off-highway and mining equipment
- Platform levelling and stabilization in industrial machines
- Navigation system component

General Description: The unit measures pitch and roll inclination angles in a full ± 180 degree orientation range. The unit can also output: gravity angle and unit accelerations in three orthogonal directions. The inclinometer transmits angular data over CAN bus using a standard J1939 protocol. The unit original configuration can be changed using Axiomatic Electronic Assistant® PC-based configuration tool.

Ordering Part Numbers:

Inclinometers:

AX060800 – Triaxial Inclinometer, CAN (SAE J1939), 2 M12 Connectors

AX060808 – Vertical Mount, Triaxial Inclinometer, CAN (SAE J1939), 2 M12 Connectors

AX060805 – Triaxial Inclinometer, CAN (CANopen), 2 M12 Connectors (See TDAX060805.)

Accessories:

AX070502 - Electronic Assistant®

AX070140 - Screw Plug PROT-FB M12 1555538



In Europe:

Axiomatic Technologies Oy
Höytämöntie 6
33880 LEMPÄÄLÄ - Finland
Tel. +358 103 375 750
Fax. +358 3 3595 660
www.axiomatic.fi

In North America:

Axiomatic Technologies Corporation
5915 Wallace Street
Mississauga, ON Canada L4Z 1Z8
Tel. 1 905 602 9270
Fax. 1 905 602 9279
www.axiomatic.com

Technical Specifications:

Static Parameters

Parameter	Value	Remarks
Measurement Range	±180° – Pitch & Roll 0...180° – Gravity	
Resolution	0.35°	Effective Resolution (3.46*NoiseRMS). Maximum at cut-off frequency, Fc=5Hz
Initial Accuracy	±2°	Maximum, at 25°C
Temperature Drift	±3.5°	Maximum, in the full temperature range: - 40...85°C
Nonlinearity	±0.7%	Maximum, at 25°C
Cross-Axis Sensitivity	±3.5%	Maximum, at 25°C

Dynamic Parameters

Parameter	Value	Remarks
Cut-off frequency, Fc	1...50 Hz, 5 Hz default	User selectable
Settling time	≤0.2s	Typical at default Fc. From 0 to 95% of the static output value.

Inputs

Parameter	Value	Remarks
Supply Voltage	9...36 VDC	12V, 24V – nominal
Supply Current ¹	20 mA 30 mA	Maximum at 24V Maximum at 12V
Protection	Reverse polarity, Transients ²	

¹ CAN bus is connected.

² Withstands 80 VDC @25°C for 2minutes for jump start conditions

CAN Output

Parameter	Value	Remarks
Number of ports	1 CAN Port	To output data and change the internal configuration of the inclinometer.
Communication standards	SAE J1939 ISO 11898 Bosch CAN protocol specification 2.0, Part A, B.	Full support for a J1939 ECU is provided. By default, the inclinometer transmits angular information on the CAN network in PGN 61459, Slope Sensor Information. User configurable PGNs are also available. 120Ohm terminated twisted pair, baud rate up to 1MBit/s. Termination resistor is not installed. For the internal CAN controller.
Protection	Short circuit to ground Connection to the power supply	 Only for 12V systems

General Specifications

Parameter	Value
Sensor Type	MEMS
Internal Logic	User Configurable with Electronic Assistant (EA), AX070502
Operating Temperature	-40...+85 °C
Environmental Protection	IP67
Vibration and Shock ¹	<p>The sinusoidal component of the vibration testing was conducted following MIL-STD-202G, method 204D, test condition C (10g peak). A resonant frequency analysis was performed, no resonances were noted.</p> <p>Sweep Characteristic: 10Hz to 2000Hz to 10Hz Sweep Period: 20 Minutes Test Duration: 8hrs/axis Test Intensity: 10g Peak</p> <p>The random component of the vibration testing was conducted meeting or exceeding the requirements of MIL-STD-202G, method 214A, test condition I/B (7.68 Grms):</p> <p>Frequency Range: 5Hz to 2000Hz Test Duration: 8hrs/axis Overall Grms: 7.68 Grms</p> <p>The shock component of the vibration testing is based on MIL-STD-202G, method 213B, test condition A. The pulse duration was shortened to 9 ms from the standard 11 ms due to our vibration system limits. Eight pulses per axis were performed instead of six. The test was conducted as follows:</p> <p>Pulse Type: half sine Pulse Duration: 9 ms Peak Value: 50 g Pulses per axis: 8</p>
Enclosure	Cast Aluminum enclosure, anodized with two 5-pin M12 A-coded round connectors. Refer to dimensional drawing.
Size	Refer to dimensional drawing.
Weight	0.75 lb. (0.34 kg)

¹MEMS sensor can withstand 20000 g max.

Compliance

Enclosure Protection

Standard	Description	Conditions
IEC 60529	Degrees of protection provided by enclosures (IP Code).	IP67. Mating connectors compliant with IEC 61076-2-101:2012 should be installed.

Name	Remarks
CE Marking	EMC RoHS

Installation Instructions:

The CAN wiring is considered intrinsically safe. All field wiring should be suitable for the operating temperature range of the module. CAN wiring may be shielded using a shielded twisted conductor pair and the shield must be connected to the CAN_SHIELD pin.

Dimensions:

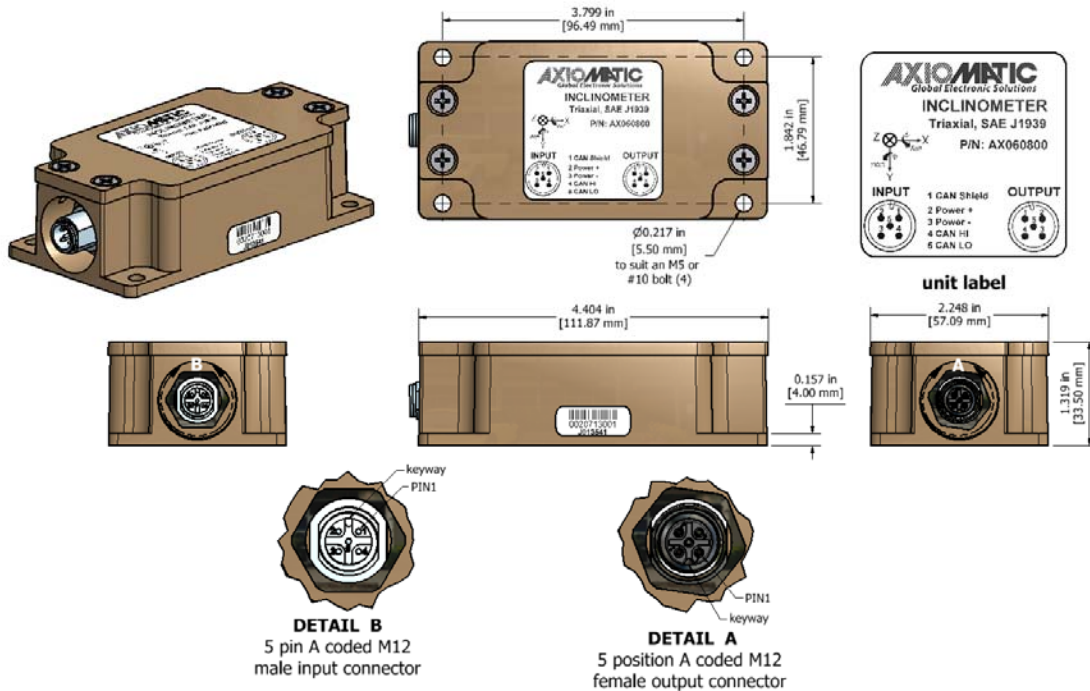

Electrical Connections:

Model: AX060800, AX060808

There is only one CAN port supported by the unit. Both CAN connectors are physically connected to facilitate cable routing in the user system.

The unit contains two 5-pin M12 A-coded round connectors. Use mating connectors compliant with IEC 61076-2-101:2012.

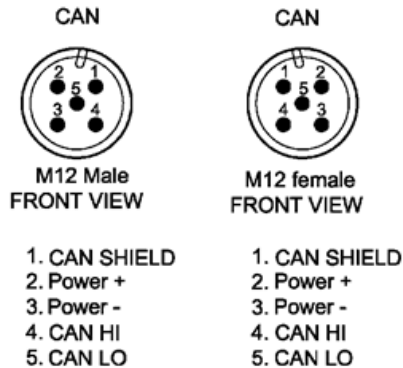

Unit Orientation:

Model: AX060800

The unit coordinates, together with the Pitch and Roll directions are shown on the inclinometer label.

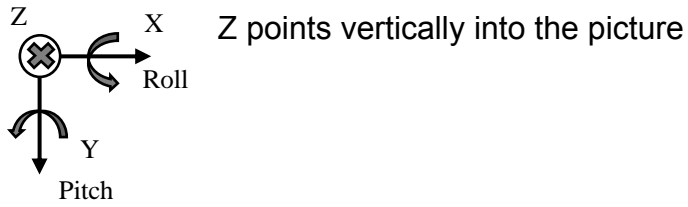

Model: AX060808

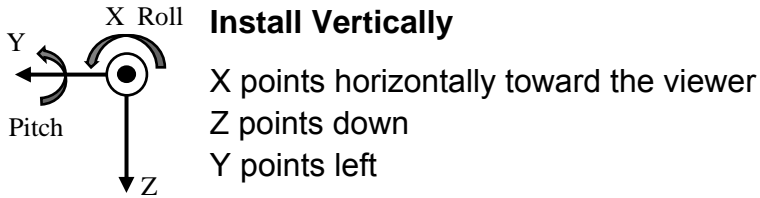

Notes: Electronic Assistant® is a registered US trademark of Axiomatic Technologies Corporation.
CANopen® is a registered community trade mark of CAN in Automation e.V.

Specifications are indicative and subject to change. Actual performance will vary depending on the application and operating conditions. Users should satisfy themselves that the product is suitable for use in the intended application. All our products carry a limited warranty against defects in material and workmanship. Please refer to our Warranty, Application Approvals/Limitations and Return Materials Process as described on www.axiomatic.com/service.html.

Form: TDAX06080X-09/08/18