

CWTF15-3, PF (2U/1L Warmer)

18.9" x 17.8" x 8.5"
(48.0cm x 45.2cm x 21.6cm)

- Model is space-saving 8.5" (21.6cm) wide
- All stainless steel construction
- Hot water faucet and pourover feature
- SplashGard® funnel deflects hot liquids away from the hand



 Servers and airpots sold separately

Agency:



Specifications

Product #: 12950.0213

Warmers: Two Upper/ One Lower

Water Access: Plumbed

Finish: Stainless

Funnel: Black Plastic

Faucet: Upper

Additional Features

Pourover Option

Electrical & Capacity

Volts	Amps	Watts	Cord Attached	Plug Type	8oz cups/hr 236ml cups/hr	Input H ² O Temp.	Phase	# Wires plus Ground	Hertz
120	13.9	1670	Yes	NEMA 5-15P	61	60°F (15.5°C)	1	2	60

Plumbing Requirements

PSI	kPa	Fitting Supplied	Water Flow Required (GPM)
20-90	138-621	1/4" Male Flare Fitting	-

CAD Drawings

2D	Revit	KLC
●		



BUNN® reserves the right to change specifications and product design without notice. Such revisions do not entitle the buyer to corresponding changes, improvements, additions or replacements for previously purchased equipment. For most current specifications and other info visit bunn.com.

Created on:
01/25/2016

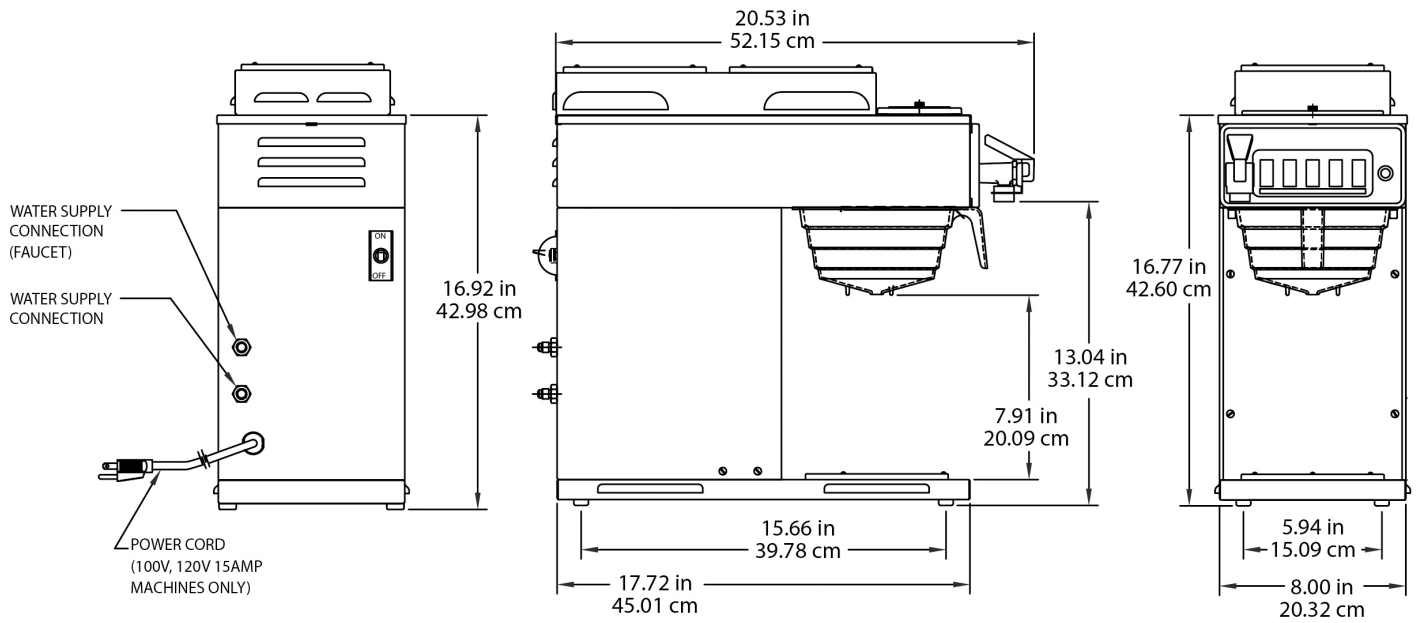
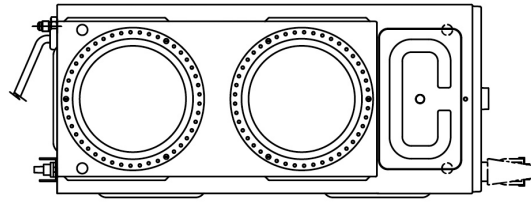

Unit			Shipping					
	Width	Height	Depth	Width	Height	Depth	Weight	Volume
English	8.5 in.	18.9 in.	17.8 in.	-	-	-	33.057 lbs	3.915 ft ³
Metric	21.6 cm	48.0 cm	45.2 cm	-	-	-	14.995 kgs	0.111 m ³



BUNN® reserves the right to change specifications and product design without notice. Such revisions do not entitle the buyer to corresponding changes, improvements, additions or replacements for previously purchased equipment. For most current specifications and other info visit bunn.com.

Created on:
01/25/2016

Related Products & Accessories: CWTF15-3, PF (2U/1L Warmer)(12950.0213)



FILTERS,REGULAR1M
500/2 50/CL

Product #: 20115.0000



FUNNEL W/DECALS,
BLACK PLASTIC

Product #: 20583.0003



WATER FILTER
SYSTEM, EQ-17-TL

Product #: 30200.1000



WATER FILTER,IN LINE
ED-17-TL

Product #: 30201.1001



BUNN® reserves the right to change specifications and product design without notice. Such revisions do not entitle the buyer to corresponding changes, improvements, additions or replacements for previously purchased equipment. For most current specifications and other info visit bunn.com.

Created on:
01/25/2016

Serving & Holding Options: CWTF15-3, PF (2U/1LWarmer)(12950.0213)



EASY POUR,(BLK) 1/CS

Product #:06100.0101



EASY POUR,(BLK) 2/CS

Product #:06100.0102



EASY POUR,(BLK) 3/CS

Product #:06100.0103



EASY POUR,(BLK) 6/CS

Product #:06100.0106



EASY POUR,(BLK) 12/CS

Product #:06100.0112



EASY POUR,(BLK) 24/CS

Product #:06100.0124



EASY POUR,(BLK) 6-1/2 CS

Product #:06100.0156



EASY POUR,(ORN) 1/CS

Product #:06101.0101



EASY POUR,(ORN) 2/CS

Product #:06101.0102



EASY POUR,(ORN) 3/CS

Product #:06101.0103



EASY POUR,(ORN) 6/CS

Product #:06101.0106



EASY POUR,(ORN) 12/CS

Product #:06101.0112



EASY POUR,(ORN) 24/CS

Product #:06101.0124



DECANTER, GLASS-BLK 12C 24/CS

Product #:42400.0024



DECANTER, GLASS-BLK 12CUP 1PK

Product #:42400.0101



DECANTER, GLASS-BLK 12C 3/CS

Product #:42400.0103



DECANTER, GLASS-ORN 12C 24/CS

Product #:42401.0024



DECANTER, GLASS-ORN 12 CUP 1PK

Product #:42401.0101



DECANTER, GLASS-ORN 12C 3/CS

Product #:42401.0103



BUNN® reserves the right to change specifications and product design without notice. Such revisions do not entitle the buyer to corresponding changes, improvements, additions or replacements for previously purchased equipment. For most current specifications and other info visit bunn.com.

Created on:
01/25/2016