



TWIN RAIL™ HIGHWAY PEG MOUNTS

PARTS INCLUDED

- 1 Right Twin Rail Footrest
- 1 Left Twin Rail Footrest
- 1 Clamp Clevis Mount Right Assembly
- 1 Clamp Clevis Mount Left Assembly

INSTALLATION INSTRUCTIONS:

1. Park on a level surface and shut off the motorcycle. Ensure that the engine has had time to cool before installation.
2. Prepare the clamp and engine guard surface by using soap and hot water to remove any dirt followed by an ammonia based glass cleaner to remove any wax or oil.
3. Remove the 1/2" hex bolt from the clamp assembly. Separate the clamp halves and place them around the engine guard. The serrated face of the clamp should be facing outward and away from the motorcycle.

NOTE: The ear of the clamp could point to the rear of the motorcycle for average height riders and to the front for tall riders. (FIG.1.)

4. In its approximate final location, reinstall the hex bolt and thread it into the clevis until finger tight. Adjust the assembly to the desired position.

CAUTION: *Ciro* recommends a thread locking fluid such as 3M Scotch-Weld TL-43 for this installation.

WARNING:

This indication alerts you to the fact that ignoring the contents described herein can result in potential serious injury or death if not followed.

CAUTION:

This indication alerts you to the fact that ignoring the contents described herein can or will result in material damage and/or personal injury.

ATTENTION:

This indication alerts you to the fact if you ignore this detail you will affect the performance or functionality of the product.

All *Ciro* products are designed for "easy assembly" and/or "plug and play". We recommend a competent mechanic install our products, using standard mechanical procedures to assure a safe and successful installation.

FIG.1

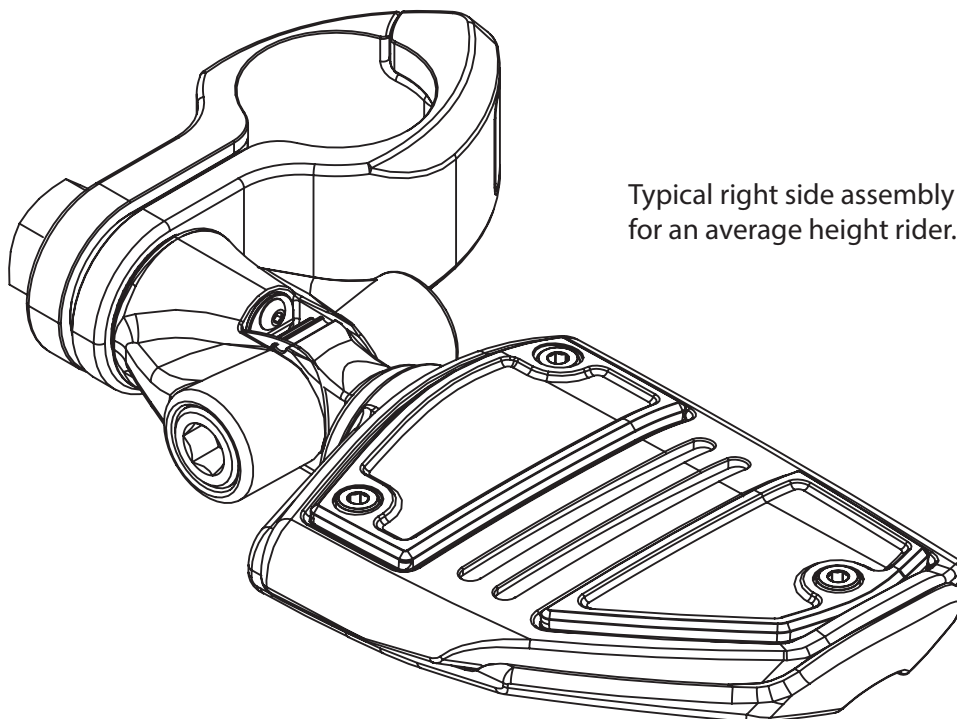

NOTE:

Ciro® warrants that products sold hereunder to the original purchaser, if maintained and operated under normal conditions, shall be free from any defects in materials and workmanship for a period of (3) years from date of purchase, and a lifetime warranty against LED failure.

Ciro will have no obligation if the customer cannot show proof of purchase.

Warranty will not be granted unless the part is properly installed and maintained.

Ciro will not be liable for any consequential and incidental damages, including labor, or non-*Ciro* products.

Please visit our website Ciro3d.com for our complete warranty policy.



5. Install the Twin Rail Footrests and adjust the angle to your liking.

NOTE: Adjust the angle of the clevis attached to the clamp to affect how the footrest folds.
Adjust the angle of the footrest on the footrest adapter to find a comfortable position.

6. Check and securely tighten all fasteners.

CAUTION: Ciro recommends a thread locking fluid such as 3M Scotch-Weld TL-43 for this installation.

(A.) 1/2" hex bolt holding the clamp should be tightened to 40-45 ft.-lb. torque.

(B.) 3/8" socket head screw in the clevis should be tightened to 12-16 ft.-lb. torque.

(C.) 5/16" socket head screw in the footrest should be tightened to 10-13 ft.-lb. torque.

