



LIGHTED LICENSE PLATE FRAME FOR TRI-GLIDE

PARTS INCLUDED

- 1 Chrome housing with lights
- 1 Mounting bracket
- 1 Installation kit

INSTALLATION INSTRUCTIONS:

1. Park on a level surface and shut off the motorcycle. Ensure that the engine has had time to cool before installation.
2. Remove the license plate and set it aside. Remove the license plate bracket and set aside the torx screw for reinstallation. Remove the rectangular rubber spacer from the back of the bracket and set it aside for reinstallation. (FIG.1)
3. Open the trunk door. Remove the inner liner and set it aside for reinstallation. (FIG.2)
4. Apply the rectangular rubber spacer from step 2 onto the included mounting bracket. Install the mounting bracket with the factory torx screws. Leave the screws a little loose so the mounting bracket can slide but still hold its position. (FIG.3) (FIG.4)

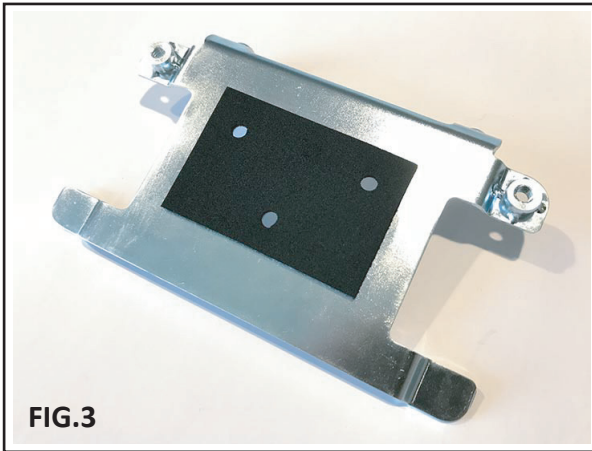
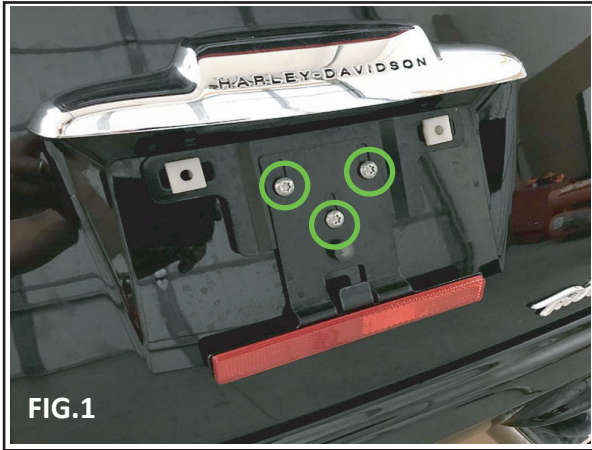

5. Test fit the chrome housing with lights onto the mounting bracket. Install it using the provided long Phillips screws, lock washers, and spacers. Check that the **Ciro** chrome housing with lights is centered and fits tightly up against the chrome license light housing. If there is a gap you can slide the bracket to ensure a tight fit. When you are satisfied with the fit, tighten the torx screws holding the bracket. Remove the **Ciro** chrome housing.

6. Select a 5/16" or 8mm drill bit that fits into the top center hole in the mounting bracket and drill through. Use a round file to help remove any rough edges. (FIG.4)

7. Install the rubber grommet. A little bit of lubricant (spray oil, glass cleaner, spray wax) and a small Phillips screw driver can be helpful while working the grommet into place. (FIG.4)

WARNING:

This indication alerts you to the fact that ignoring the contents described herein can result in potential serious injury or death if not followed.

CAUTION:

This indication alerts you to the fact that ignoring the contents described herein can or will result in material damage and/or personal injury.

ATTENTION:

This indication alerts you to the fact if you ignore this detail you will affect the performance or functionality of the product.

All **Ciro** products are designed for "easy assembly" and/or "plug and play". We recommend a competent mechanic install our products, using standard mechanical procedures to assure a safe and successful installation.

NOTE:

Ciro® warrants that products sold hereunder to the original purchaser, if maintained and operated under normal conditions, shall be free from any defects in materials and workmanship for a period of (3) years from date of purchase, and a lifetime warranty against LED failure.

Ciro will have no obligation if the customer cannot show proof of purchase.

Warranty will not be granted unless the part is properly installed and maintained.

Ciro will not be liable for any consequential and incidental damages, including labor, or non-**Ciro** products.

Please visit our website Ciro3d.com for our complete warranty policy.

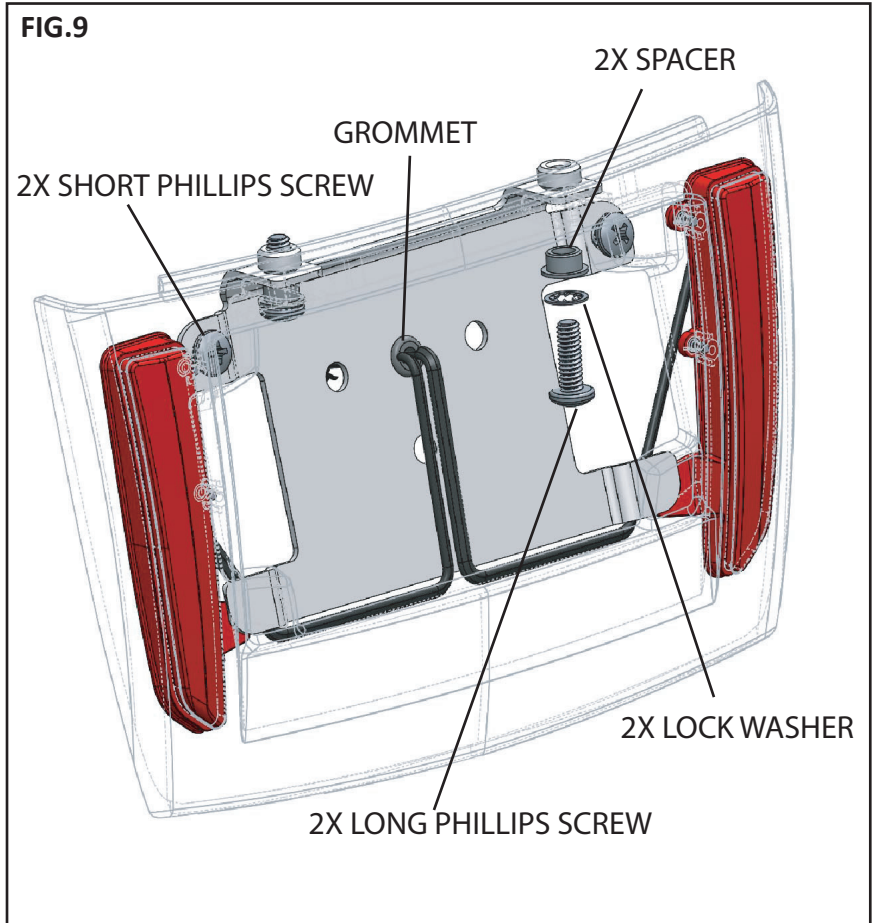
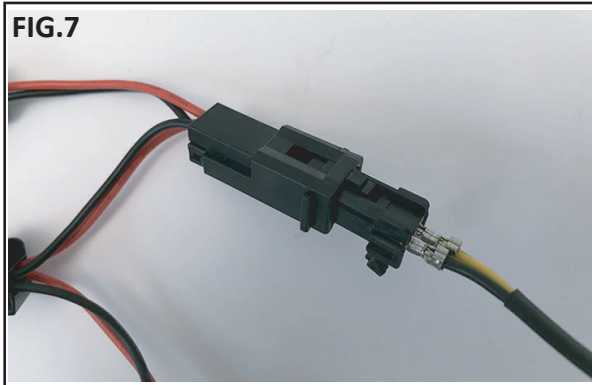
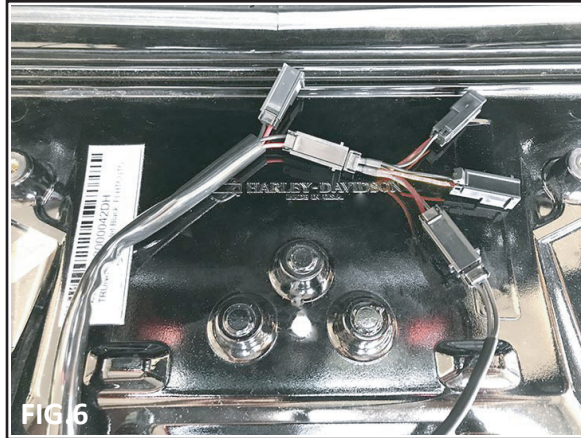
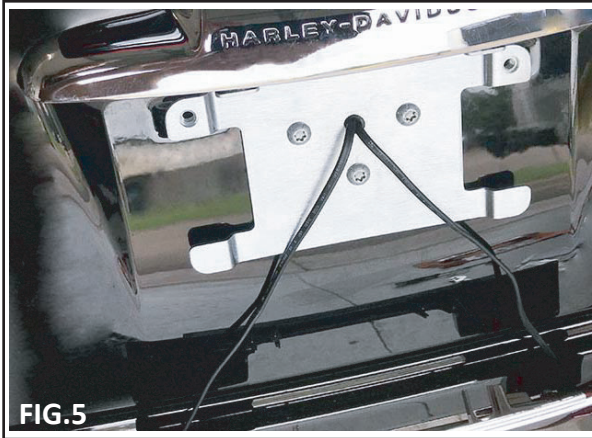

8. Hold the chrome housing upside down with the bottom edge near the trunk door. Run the wires into the rubber grommet. A little bit of lubricant (spray oil, glass cleaner, spray wax) will help. Be careful not to bend or crush the electrical pins. Pull the wires into the trunk lid about 3 inches. (FIG.5)
9. Unplug the OEM license plate light wiring and plug in the **Ciro** wiring harness. Insert the bare terminals from the **Ciro** license lights into the connectors. Double check that the colored wires line up before pushing them into place. Black to black, yellow to red. Turn on the motorcycle ignition and check the lights. (FIG.6) (FIG.7)
10. Hold the chrome housing in its installed position and make sure the wires are not pinched. Gently pull excess wire slack to the inside of the trunk lid.
11. Reinstall the license plate using the provided short Phillips screws. Install the housing using the provided long Phillips screws, lock washers, and spacers.
12. Reinstall the trunk door liner. (FIG.2)