

dedolight®

PRECISION LIGHTING INSTRUMENTS



NEWS 2019

ENGLISH 04/2019

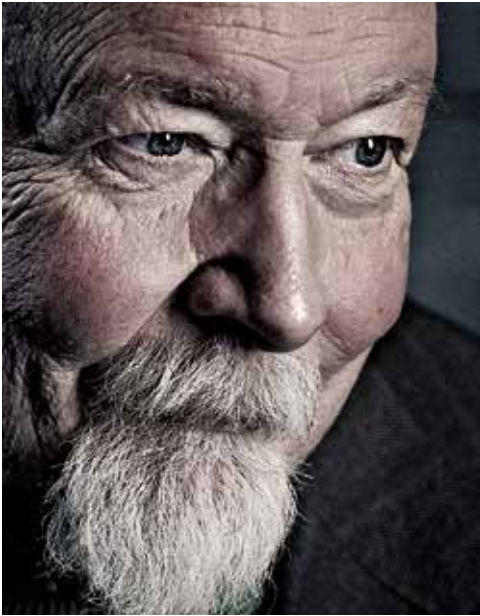

My name is Dedo.

I am a cameraman/Director of Photography.

I've shot documentaries, commercials, art films, features and theatre plays in over forty countries. I am also a high-speed specialist (film and video). Today, dedolight is widely known and acclaimed for precision lighting instruments.

I am very proud of my unique team at dedolight.

No manufacturer in our field has as many experienced, recognized and practicing Directors of Photography in the Team as we do.

We listen to and enjoy the dialogue with some of the best known cinematographers shooting multi-million dollar blockbusters as well as the intensely creative small crews who shoot under street fighter conditions. Many ideas and constructive criticism comes from these colleagues.

Our research and development is done "in-house" and I am very proud of our exceptional team of optical engineers, electronic geniuses, computer gurus and seasoned high class mechanical engineers. We collaborate with several light source manufacturers and continue to develop better, more efficient and precise light sources. We combine leading edge optical design (over 30 patents) with the most modern fixture and ballast concepts. We remain committed to create the best possible tools and control devices in precision lighting for the professional.

We are proud to introduce the latest marriage of prime class LED technology with our patented double aspherical dedolight optics and LED panel soft lights.

dedolight provides the highest optical precision and unique tools for light control and light shaping. These are available in an eco-friendly halogen version, new tungsten metal halide – interchangeable with our daylight metal halide sources and several versions of the best LED technologies in the dedocolor® quality! We value the extraordinary team of dedolight agents around the world. Many share common roots in the practicing profession and an enthusiasm and dedication to the art of lighting.

LED BREAKTHROUGH

Digital cameras see LED light differently than tungsten/daylight sources meaning they interpret light sources differently. Color temperature meters are unable to see the full spectrum and therefore do not work for the evaluation of LED light.

Samples are only taken in three or four places of the spectrum. Spectrum analysis and CRI values offer a serious step for evaluation, but usually do not include colors such as R9 (red) and R13 (skin tone) - both extremely critical values.

Even expanded CRI evaluations do not offer reliable criteria. TLCI (Television Lighting Consistency Index), the new standard of the European Broadcasting Union (EBU), offers a better and more reliable base for the way studio cameras see LED light.

These studio cameras usually work with three CCD sensors. Thus, the results are not really indicative of the way different CMOS cameras see LED color.

For a number of years we have been conducting tests with various digital cameras and different skin tones. In these tests we light one side of the Face with a reference light and the other with LED light. Our LED lights show a perfect match between reference light and our LED lights as seen by the vast majority of CMOS cameras.

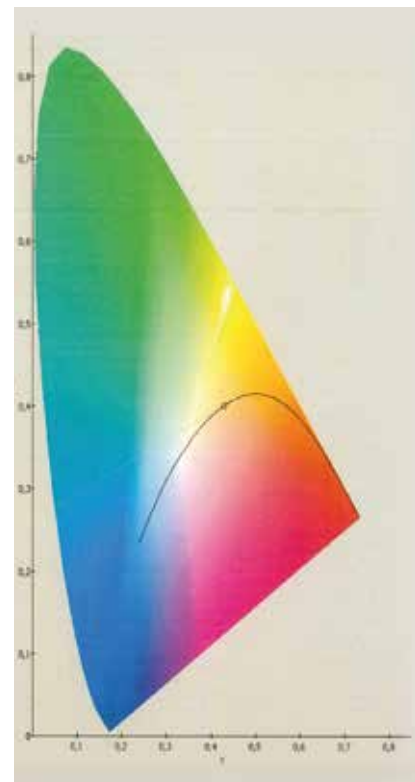
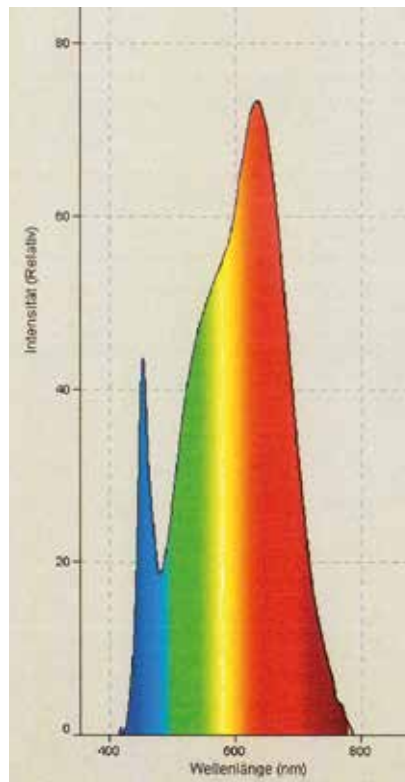

Spectral distribution (left) and color coordinates show that our DLED4 bicolor light (in tungsten function) is perfectly placed on the Planck Curve (right).

CRI Ra (1-8)	97	TLCI 97
CRI Ra' (1-14)	96	
CCT	3112K	

R1	R2	R3	R4	R5	R6	R7	R8
98	98	95	97	96	95	98	96

R9	R10	R11	R12	R13	R14	R15
89	92	96	95	98	96	89

Measurements with our 40W DLED4 bicolor light in tungsten function
Expanded CRI evaluation: 15 colors

NEW:

FELLONI3

Vastly improved color, same as previous dedocolor quality

Available as bicolor high output, as daylight high output and as bicolor standard output

TURBO FELLONI

Only available in high output bicolor version

Light output 5 x higher than previous Felloni panel, also here optimum color quality

Further and more detailed informations are to be found in a separate Felloni brochure including all possible accessories, power options and packaging. In this catalog, Fellenis are to be found in combination kit with other focusing lights. See pages 18 and 19.

Focusing LED lights present special challenges regarding color distribution.

Specially developed LED light sources in combination with our patented double-aspheric technology (recognized by the Oscar committee for Technical Achievement) have allowed us to provide five different dedolight DLED focusing LED light fixtures.

All deliver perfect light distribution, the widest focusing range in the industry and allow the use of our unique line of light shaping accessories. Available in daylight, tungsten and bicolor. Bicolor is variable from 2700K to 6500K

The following DLED focusing lights work with passive cooling (no fan - no noise).
 Ledzilla 8 W, DLED2 20W, DLED4 40W, DLED9 90W

Active cooling is used on DLED12 (2500W) as well as DLED30 (300W).

Also again in super quiet function on the new Turbo light generation, which is described in a separate catalog. DLED3, DLED7, DLED10.

Health hazards

In the past, metal halide lamps have been known to cause skin cancer and cataracts due to the short wave-length ultraviolet rays.

We have always offered the lowest and safest UV value in the industry.

LED light sources can create a health hazard by their unavoidable blue peak.

Our products comply with the requirements of biohazard standard EN6247 in the category of "exempt" (without any health hazard criteria).

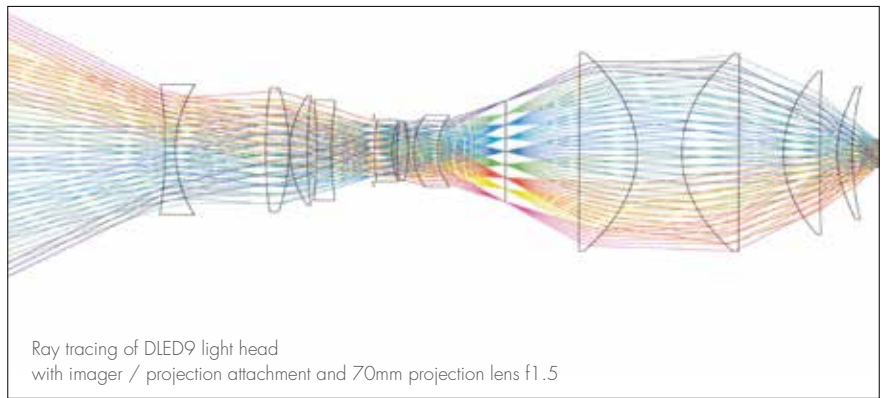

Ray tracing of DLED9 light head with imager / projection attachment and 70mm projection lens f1.5

DLED-BI measured in the lowest tungsten color temperature 2629K. TLCI 97

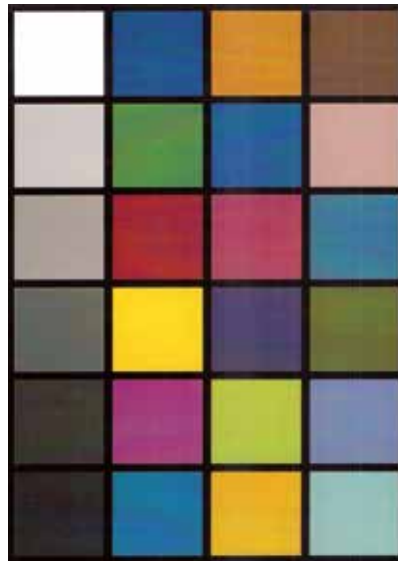

Television Lighting Consistency Index - 2012

Sector	Lightness	Chroma	Hue
R	0	0	0
R/Y	0	0	0
Y	0	0	0
Y/G	0	0	0
G	0	0	0
G/C	0	0	0
C	0	0	0
C/B	0	0	-
B	0	-	0
B/M	0	0	+
M	0	+	+
MR	0	0	0

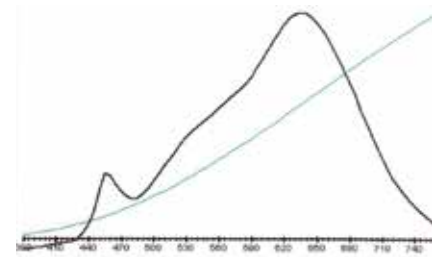

The spectral curve shows that we have managed to avoid the deep valley next to the blue peak. This offers optimum security regarding photo-biological hazard. The table above also shows that this light does not need any correction in post-production.



<http://www.youtube.com/user/dedoweigertfilm>

- EASY LIGHTING FOR THE SMALL TEAM - tutorial videos
- LEARN LIGHTING FROM THE MASTERS - tutorial videos
- DEDOLIGHT LIGHTING INSTRUMENTS & TOOLS - videos about our unique products
- DEDOLIGHT IN PHOTOGRAPHY - photo shootings and interviews made with dedolight
- INTERVIEWS / BEHIND THE SCENES - learn more about how professionals use our products and a lot more...



Easy lighting for the small team



Learn lighting from the Masters



dedolight: Lighting instruments & tools



dedolight in photography



dedolight: Instructional videos



Q&A - interviews with cinematographers & ...



International dedolight Competition 2015 - Results ...



Behind the scenes



Trade fair interviews & dedolight workshops around the world



Collection of international dedolight videos



Sammlung von deutschsprachigen dedolights ...



Dedo about filmmaking

COMPLETE RANGE OF FOCUSING DEDOLIGHT LED FIXTURES

8 DIFFERENT SIZES:

All share the following characteristics:

- LED light sources, specially developed for dedolight. Latest technology. Highest dedocolor quality
- Patented dedolight aspherical optics
- The astounding efficiency is an enormous advantage in mobile use which makes battery operation possible up to the DLED9 (90W light head).



- Unprecedented focus range (wider/narrower)
- A clean beam concept, only offered by dedolight. The precision controlled light beam offers perfectly smooth light distribution within the beam – outside with any stray light.
- The DLED9 and DLED12 lights, mainly conceived for studio operation. DLED9 lights also ideal for mobile teams.
- Our new LED turbo series works with active in an extremely low noise variation. Drastically enhanced light output: DLED3, DLED7 and also our new flagship light for mobile drama, the DLED 10 – accompanied by the super power studio version DLED30. See separate Turbo catalog and flyers for DLED10 and DLED30
- All of these lights share exceptional light shaping control:
 - Precise barn door shadows.
 - Scrim, double, full, half and graduated.
 - Graduated grey glass filters (only from dedolight)
 - Non-spherical, wide-angle attachments with rotating barn doors (dedolight patent)
 - dedolight imager/projection attachment
 - Razor-sharp light and shadow forms
 - Smooth light and shadow edges with DPEYE filters (soft edge, no diffusion)
 - Gobo projection and slide projection
 - Projection of background effect filters

With the exception of the 8 W Ledzilla and the DLED2 (20W), all of these lights are available for mobile use as well as studio versions.

The studio versions are offered as an option with pole operation and/or DMX control.

The DLED12 has DMX control as standard.

For mobile use, great advantage is offered by our bicolor lights, allowing continuous change of color temperature from 2700 K up to 6500 K.

Our on-board Ledzilla light is also often used as off-board light for complete scenic lighting. Ledzilla and our larger DLED lights are not only offered in tungsten, daylight and bicolor variations, but also in several infrared and ultra-violet versions.

LED



YOUR DREAM - OUR FOCUSING

Complete Range in 5 different sizes

- * Patented aspherics² dedolight Optics
- * Unprecedented Focusing
- * Astounding Light Efficiency

OUR LED

TECPRO FELLONI 3

- Higher light output
- Perfect color
- 3 Versions:
 - bicolor
 - daylight high output
 - bicolor high output



LED LIGHTS



LED LIGHTS

and systems for on-board, off-board, mobile, studio & special effects.

- * Perfectly Even Light Distribution
- * Perfect color (Tungsten, Daylight, Bicolor)
- * Complete Range of Light Shaping Control Tools

PANEL LIGHTS

Tecpro Felloni Turbo, maxi power

- bicolor
- super output (5x)

Many other LED panel options include:

- Ledrama – highest output, reach and efficiency (page 34)
- Big Foot, huge bicolor and multicolor systems*
- Ledraptor 3 LED soft lights, 3, 5 and 7 ft diameter*



**see separate brochures*

DLED2 LED SMALL, POWERFUL, VERSATILE

dedolight Patented Aspheric Optics in combination with specially developed LED light sources in daylight and bicolor variations. For use as on-board or off-board light, multi-functional and versatile as tiny interview and documentary lighting, for accents and special effects. Especially useful and versatile in combination with FELLONI bicolor multi-LED panels.



DLED2-D

Monocolor. Continuous dimming with no color shift, with integrated electronics and 16 mm (5/8") stand fitting.

DLED2-BI

Same as image (A), but in bicolor version.

Continuous dimming with no color shift. Color temperature range 2700K - 6500K. One of the knobs serves for dimming, the other one for continuous change of color temperature.



DLED2HSM-D

DLED2HSM-BI

Similar to A, but with camera shoe mount for camera mounting

Note: This version can be mounted directly on the camera (hot shoe) or with adapter DLBSAJSF used on stands with 5/8" stud.

Mount Change



Camera shoe mount can be exchanged by the user to stand fitting and vice versa, as shown above.



Battery Holder Plates



DLED2-BS

Battery holder for DLED2-D/-BI. Accepts NP-F950/960/970 batteries (7.2V/47Wh)



DLED2-BSU

Battery holder for DLED2-D/-BI. Accepts Sony BPU-60 battery (14.4V/56Wh)



DLED2-BP

Battery holder for DLED2-D/-BI. Accepts CGA batteries (7.2V)



example with optional NP-F950 battery attached to DLED2 light head.

Focusing 20W LED daylight and bicolor light head with yoke and 16 mm (5/8") receptacle or with yoke and camera shoe mount. Separate DT2-BAT, DT2-BI-BAT, or DT2-BI-BAT-DMX electronics needed.



DLED2Y-D

DLED2Y-BI

separate light head for use with ballasts (ballasts shown below)



DLED2YHSM-D

DLED2YHSM-BI

with camera shoe mount

Cable to light head

three sizes of connecting (yoke versions)

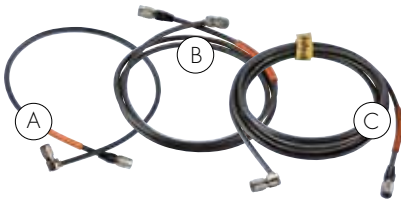

A DLED2POW0.55

Connecting cable to light head, 2' (55 cm) long

B DLED2POW1.4

Connecting cable to light head, 5' (140 cm) long

C DLED2POW3

Connecting cable to light head, 10' (300 cm) long

DC Ballasts

DT2-BAT

Dimmable monochrome ballast for DLED2Y-D/T and DLED2YHSM-D/T. Dimming with no color change. Input: 6-18V DC

DT2-BI-BAT

Dimmable bicolor ballast for DLED2Y-BI and DLED2YHSM-BI. Dimming and continuous change of color temperature from 2700 to 6500K. Input: 6-18V DC

DT2-BI-BAT-DMX

DC electronics for DLED2Y-BI and DLED2YHSM-BI with DMX control for continuous change of color temperature from daylight to tungsten.

DC Input Cables

for DC Ballasts

DDCC-XLR

Coiled cable 65 cm - 1.30 m (25-51") with 4-pin XLR connector

DDCC-CAR

1.8 m (6 ft.) with cigarette light connector

DDCC-DTAPS

28 cm (11") with D-Tap connector

DDCC-DTAPL

55 cm (22") with D-Tap connector



DS-95SI battery, 95 Wh

- V-lock mount
- 14.8V 95Wh
- Max. discharge rate up to 10A
- Input voltage for charger 90V - 240V (Including charge cable. Specify power plug needed for your country.)
- Integrated charger
- Compatible with all V-mount plates
- 5-pin connector allows communication for camera and all other V-lock equipment



DLBCA2-V

V-Mount plate with belt loop, D-Tap output, and holding plate for DT2-(BI)-BAT power supply.

Note:
95Wh battery with integrated charger and V-Mount adapter can be used on a belt and also hung on the knob of a stand (loop). This device also serves to feed DLED4 in all its various versions (see following pages).



DLBCA2-NPF

Sony NPF plate with belt loop and holding plate for DT2-(BI)-BAT power supply.

DLED2 TECHNICAL DATA

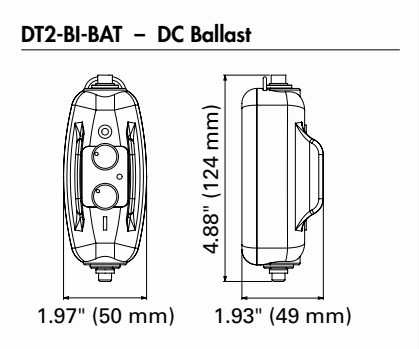
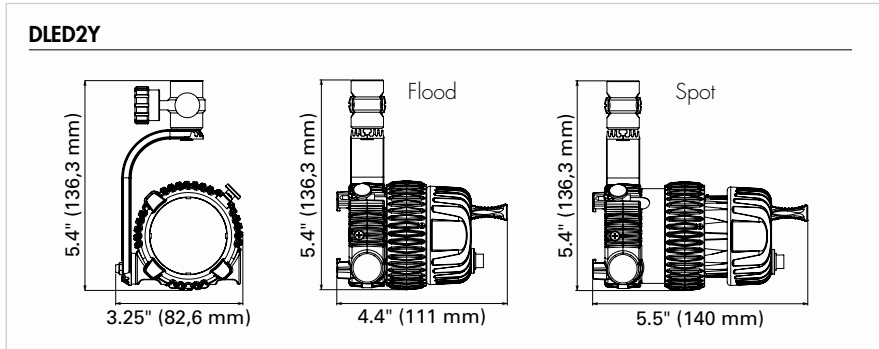
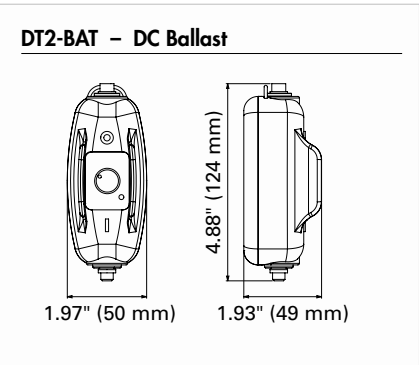
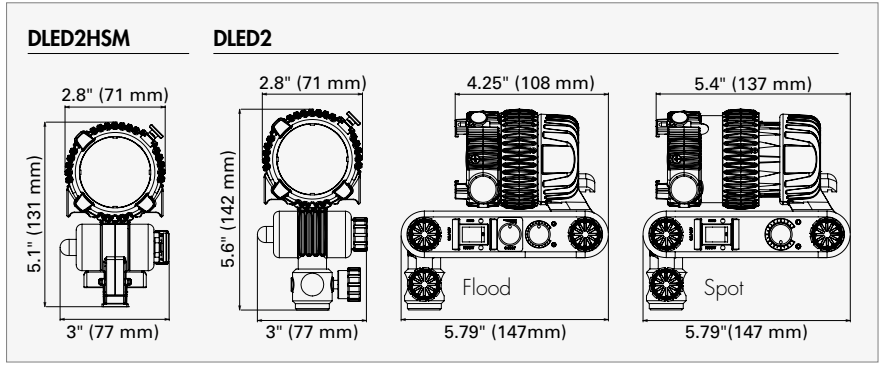

FOCUSING LED LIGHT HEAD: DLED2-D, DLED2-BI	
Focus Range (Intensity Range)	50°-5° (1:7)
Focus Control	3/4 turn on focus ring
Power	25 W, 6- 18VDC
Mounting	5/8" (16 mm) receptacle and 1 1/8" (28 mm) stud OR: optional with shoe mounting (e.g.: DLED2HSM-BI) OR: with yoke and separate power supply (e.g.: DLED2Y-BI)
Operating Position	Any, except electronics directly over light head
Tilt Control	Adjustable friction
Accessory Holder*	Ø 2.3" (58 mm)
Safety	Protection Class III, SELV, IP40
Cooling	Passive cooling (no fan)
UV	No UV radiation
Weight	1.8 lb (800g)
Size	W: 3" (77 mm) L (flood): 5.79" (147 mm) L (spot): 5.79" (147 mm) H: 5.6" (142 mm)
* for mounting the unique range of DLED2 front-end accessories	

DLED2-D Focusing LED Light Head. Daylight approx. 5600K

Distance	Meter	1	2	3	4	5
	Feet	3'	6'	9'	12'	15'
Flood	Lux	810	203	90	50	
	Foot Candle	75	19	8.3	4.6	
Medium	Lux	1,800	450	200	113	72
	Foot Candle	167	42	19	11	6.7
Spot	Lux	5,250	1,312	583	328	210
	Foot Candle	487	122	54	30	20

DLED2-BI Focusing LED Light Head. Bicolor measured at 5600K – daylight

Color temperature continuously adjustable from 2700 – 6500K

Distance	Meter	1	2	3	4	5
	Feet	3'	6'	9'	12'	15'
Flood	Lux	820	205	92	51	
	Foot Candle	76	19	8.6	4.8	
Medium	Lux	1,820	455	202	114	73
	Foot Candle	169	42	19	11	6.8
Spot	Lux	3,350	838	372	209	134
	Foot Candle	311	78	35	19	12

Bicolor in tungsten function ~ 25% lower output

DLED2 ACCESSORIES

Light Control



DBDS8

Standard 8-leaf barn door for DLED2 light head.

DBDS

Optional 8-leaf barn door with individually rotating barn door leaves



DPLSS

Light shield ring for DLED2 and DLED3 light heads



DLSR60

Speedring for DLED2 soft box



DLED2-SBX

Soft box for all DLED2 and DLED2Y light heads.



Imager



DP1S

Imager/projection attachment for gobos and background effect filters. Complete with 60mm lens and gobo holder.



DPGSETS

A set of 6 steel gobo patterns. Fits DP1S gobo holder.



DPIRS

Iris for DP1S imager.



DP2S

Imager/projection attachment with adjustable blades and 60mm lens.



Mounting Adapter



DLBSA-JSF

Adapter from 16 mm (5/8") receptacle to camera shoe mount. Fits DLED2HSM and DLED2YHSM light heads with camera shoe mount.



DLBSA-MBS

Adapter from camera shoe mount to 16 mm (5/8") receptacle. Fits DLED2 and DLED2Y light heads.

AC Power Supply



DLPS12-30

Mains power unit with connector set EU, USA, AUS, UK
If needed, the power feed between ballast and AC adapter DLPS12-30 can be elongated by extension cable DDCC-EXT5 (length 5 m (16.4 ft.))

This device works with all DLED2 light heads and DT2-(B)-BAT power supplies.



DDCC-EXT5

5 m (16.4') Mini Jack extension cable

DLED4 LED ASPHERICS²® OPTICS

A SUCCESS STORY GROWING FURTHER

- Perfect color in daylight and tungsten versions
- Expanded bicolor range:
A great gift for mobile work, tuning from 2700K all the way to above 6500K. Thus adapting to most ambient light situations without any filters. Easy fine-tuning for slightly warmer fill light or somewhat colder back light – separating the background illumination by subtle color choices.
- Dimming:
Proprietary dimming algorithms for smooth dimming, even at the low end

16-bit dimming for special studio demands as option
- AC and DC ballasts
- Battery operation:
High output – best efficiency – low power demands allow mobile teams to operate for hours, totally independent from AC power supplies. Belt clip holds battery (V-lock or AB), as well as the battery ballast and comes with a stand mounting loop.
- Studio versions also available as pole-operated and with DMX control
- Unique light-/shadow-shaping accessories – most of these are especially designed to cooperate with our highly developed optical system

Tools to modify the light and color character. Such tools are available for all sizes of our lights.

Our experienced and highly qualified R&D team is the best of all manufacturers of professional lighting equipment. With this extraordinary team we work continuously to improve color, light output, light character and the light-shaping accessories.

A completely new, parallel product range with active cooling is shown in a separate brochure: **DLED TURBO SERIES**.



DLED4 TECHNICAL DATA

DLED4-D

DLED4-T

DLED4-BI

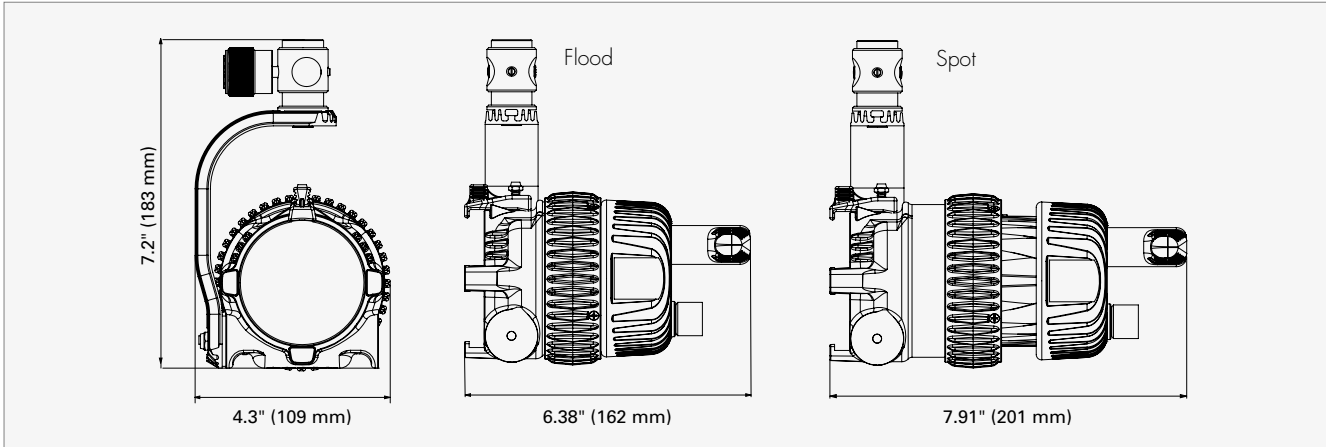

FOCUSING LED LIGHT HEAD: DLED4-D, DLED4-T, DLED4-BI

Focus Range (Intensity Range)	60-4° (1:20) with optional aspheric wide-angle attachment: 85-54°
Focus Control	One complete turn on focus ring
Power	40W
Mounting	5/8" (16 mm) receptacle and 1 1/8" (28 mm) stud
Operating Position	Any
Tilt Control	Permanent friction
Accessory Holder	3" (76 mm) diameter
Safety	Protection Class III, SELV, IP40
Cooling	Passive (no fan)
UV	No UV radiation
Weight	2.9 lb (1,300 g)
Size	W: 4.3" (109 mm) L (flood): 6.38" (162 mm) L (spot): 7.91" (201 mm) H: 7.2" (183 mm)

DLED4-D Focusing LED Light Head. Daylight approx. 5600K

Distance	Meter	1	2	3	4	5
	Feet	3'	6'	9'	12'	15'
Flood	Lux	1,500	375	167	94	60
	Foot Candle	139	35	15	9	5.6
Medium	Lux	2,800	700	310	175	112
	Foot Candle	260	65	29	16	10.4
Spot	Lux	14,500	3,625	1,611	906	580
	Foot Candle	1348	337	150	84	54

DLED4-T Focusing LED Light Head. Tungsten approx. 3200K

Distance	Meter	1	2	3	4	5
	Feet	3'	6'	9'	12'	15'
Flood	Lux	1,360	340	151	85	54
	Foot Candle	126	32	14	8	5
Medium	Lux	2,250	563	250	141	90
	Foot Candle	209	53	23	13	8.4
Spot	Lux	12,200	3,050	1,356	763	488
	Foot Candle	1,134	284	126	71	45

DLED4-BI Focusing LED Light Head. Bicolor measured at 5600K – daylight

Color temperature continuously adjustable from 2700 – 6500K

Distance	Meter	1	2	3	4	5
	Feet	3'	6'	9'	12'	15'
Flood	Lux	1,580	395	176	99	63
	Foot Candle	147	37	16	9	6
Medium	Lux	2,850	713	317	178	114
	Foot Candle	265	66	30	17	11
Spot	Lux	12,100	3,025	1,344	756	484
	Foot Candle	1,125	281	125	70	45

Bicolor in tungsten function ~ 15 % lower output

AC POWER OPTIONS FOR DLED4



DAYLIGHT / TUNGSTEN

DT4 AC power supply for DLED4 tungsten and daylight light heads.

Allows worldwide use from 90 - 264 V AC 50/60 cycle plus continuous dimming.

Add suffix "-DMX" for above ballasts with DMX control (DT4-DMX).

The DC power supply DT4-BAT is much smaller and allows operation from any 10,2-18 V source.

BICOLOR

The DT4-BI, same as DT4 but with additional control for continuous change of color temperature from daylight to tungsten. Now with digital Kelvin value display.

All bicolor ballasts for mobile use, which are used separately from the light head, work with a display, showing variations of color temperatures.

(example: C32 = color 3200 Kelvin and dimming status d50 = 50% intensity)

POWER SUPPLY FOR AC OPERATION: DT4, DT4-BI

Input Voltage	90 - 264 V AC * 50 VA / 0.5-0.21 A 47 W
Output Voltage	40V
Controls	ON/OFF switch, dimming knob
Dimming	Continuously from 100-0%
Safety	Protection Class I, IP40
Cable length (plug - > power supply)	Mains cable 8.2' / 2.5 m
Cable length (plug - > light head)	Cable to light head 4.6' / 1.4 m
Mounting	Cable loop
Weight	2.2lb / 1,000g

DT4

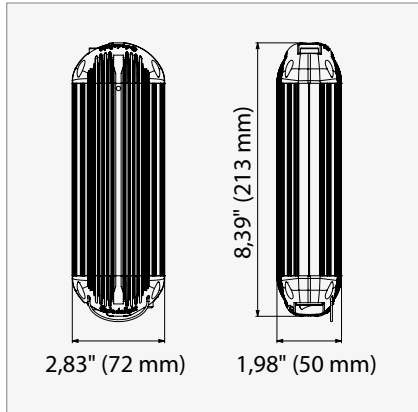

DT4-BI

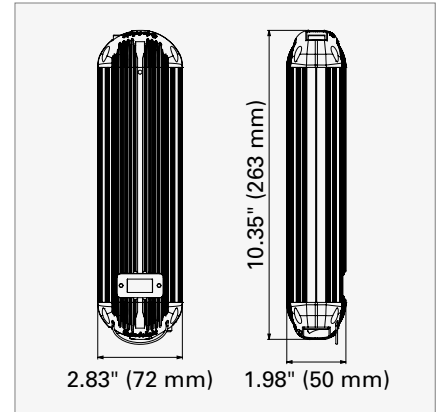

DT4-DMX

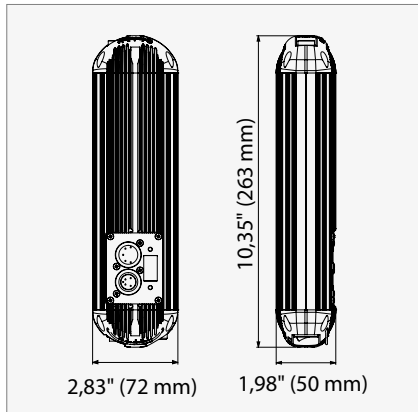

DT4-BI-DMX

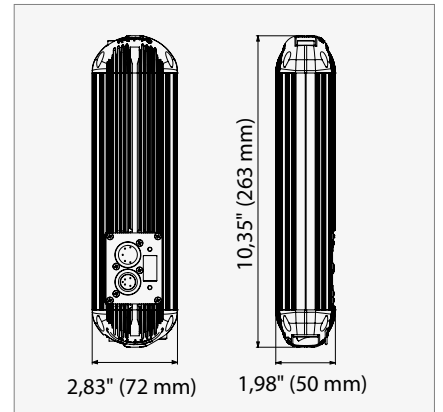

DTHC

ballast holder
to mount LED ballasts to lighting stands.
Max. opening 25,4 mm (1")

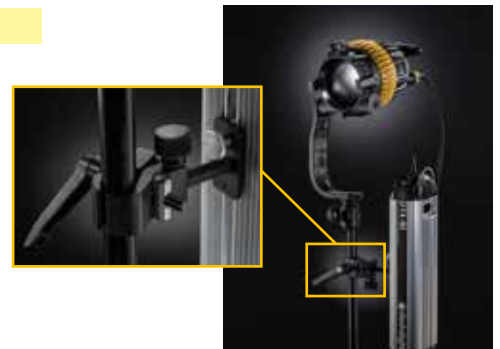

AC/DC POWER OPTIONS FOR DLED4

NEW DT4-BAT / DT4-BI-BAT POWER SUPPLY FOR AC & DC USE

DT4-BAT

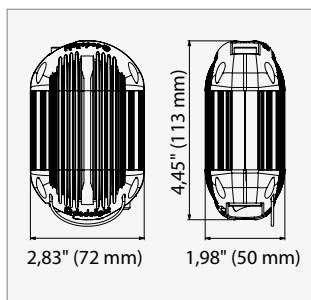

DT4-BI-BAT

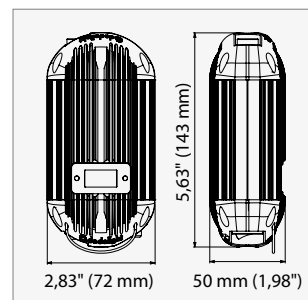

New Mini Jack socket at bottom end of DT4-BAT and DT4-BI-BAT. 10,8 – 18 V DC input.



DC USE WITH DT4-(BI-)BAT



DT4-BAT

power supply

DDCC-DTAPS

short D-Tap cable, 28 cm (11")

option:

DLBCA2-V

belt clip for V-Mount batteries

DS-95SI

14,4 V battery, 95 Wh

DDCC-CAR

adapter cable to car cigarette lighter

DDCC-DTAPL

long D-Tap cable, 55 cm (1.8')

DDCC - cables mentioned on page 31

AC USE WITH DT4-(BI-)BAT



DT4-BI-BAT

power supply

DLPS12-60

12 V power supply, 60 W, with Mini Jack

option:

DDCC-EXT5

5 m (16.4') Mini Jack extension cable



DLED4SE - STUDIO EDITION TECHNICAL DATA

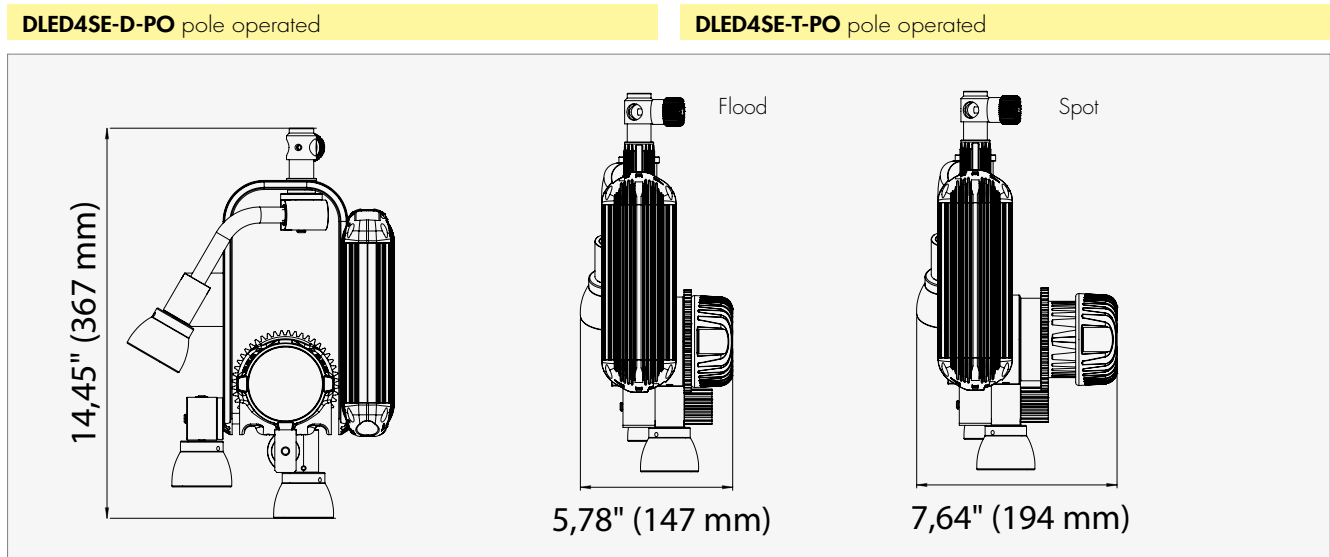
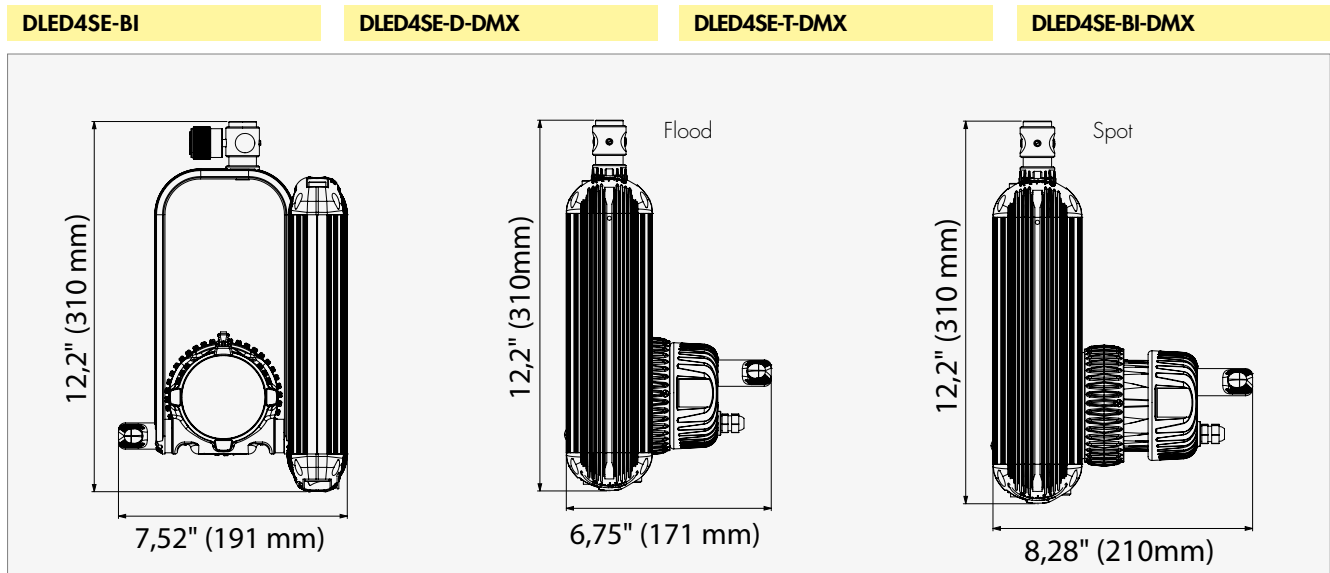
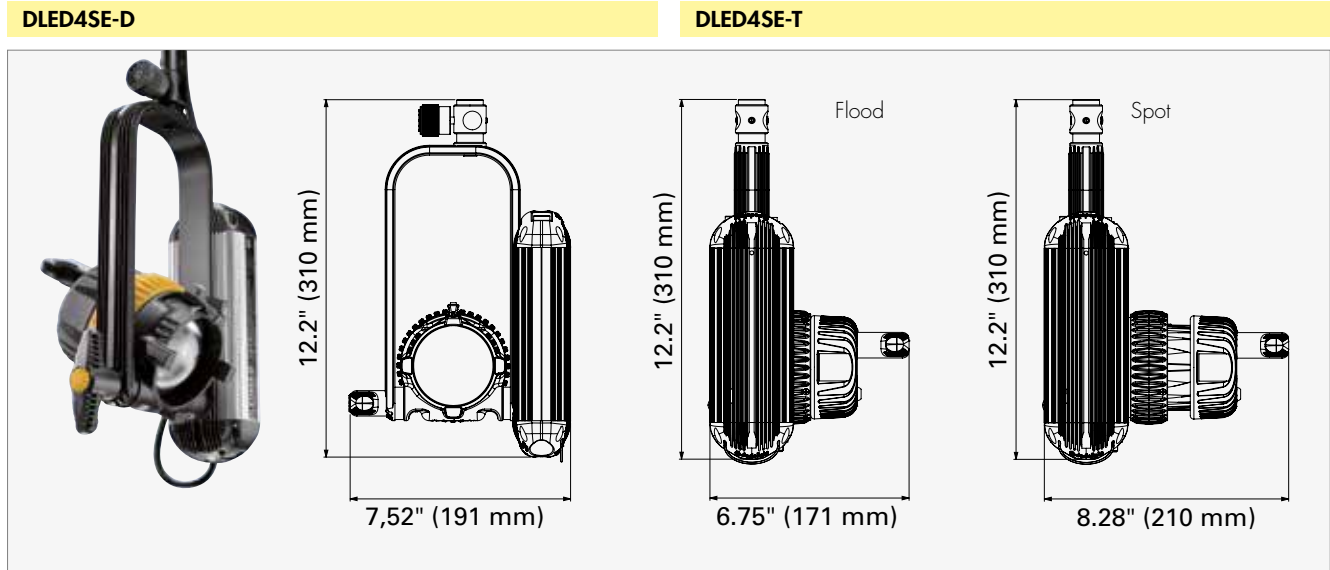

NEW: DLED4/FELLONI KITS

DLED4 1 LIGHT KIT – WITH SOFT CASE

SLED1-BI-B

SLED1-BI-B 1 Light Kit	Bicolor - Basic AC/DC operation
1 DLED4-BI	dedolight focusing LED light head, bicolor
1 DT4-BI-BAT	Battery power supply for DLED4 bicolor light heads
1 DDCC-DTAPS	Short D-Tap cable, 28 cm (11")
1 DLPS12-60	12 V power supply, 60 W
1 DPLS	Light shield ring
1 DBD8	Standard barn door (eight leaves)
1 DLHAND	dedolight handle
1 DS-95SI	14,4V battery with internal charger and charge cable
1 DLBCA2-V	Belt adapter for V-Mount batteries with holding plate for DT4(-BI)-BAT power supplies. D-Tap power out socket.
1 DSCM	Soft case, mono
Size:	28 x 17 x 25 cm (11 x 6.7 x 10")
Weight:	4.8 kg (10.6 lbs)

SLED1-D-B

SLED1-D-B 1 Light Kit	Daylight - Basic AC/DC operation
Same as SLED1-BI-B, but as 40 W daylight system with DLED4-D and DT4-BAT power supply instead of bicolor units.	



DLED4 1 LIGHT KIT – WITH SOFT CASE

SLED1-BI-M

SLED1-BI-M 1 Light Kit	Bicolor - Master AC/DC operation
<i>(items in bold are in addition to BASIC kit)</i>	
1 DLED4-BI	dedolight focusing LED light head, bicolor
1 DT4-BI-BAT	Battery power supply for DLED4 bicolor light heads
1 DDCC-DTAPS	Short D-Tap cable, 28 cm (11")
1 DLPS12-60	12 V power supply, 60 W
1 DPLS	Light shield ring
1 DBD8	Standard barn door (eight leaves)
1 DLHAND	dedolight handle
1 DLSR70	Speed ring for Classic Series and DLED4 light heads
1 DSBSXS	dedoflex mini soft box - 30x30x23cm (12x12x9")
1 DLGRIDXS	Grid (40°), fits mini soft box
1 DS-95SI	14,4V battery with internal charger and charge cable
1 DLBCA2-V	Belt adapter for V-Mount batteries with holding plate for DT4(-BI)-BAT power supplies. D-Tap power out socket
1 DSCM2	Soft case, mono
Size:	35 x 21 x 28 cm (13.8 x 8.3 x 11")
Weight:	5.2 kg (11.5 lbs)

SLED1-D-M

SLED1-D-M 1 Light Kit	Daylight - Master AC/DC operation
Same as SLED1-BI-M , but as 40 W daylight system with DLED4-D and DT4-BAT power supply instead of bicolor units.	



DLED4/FELLONI (2x1) 3 LIGHT KIT – WITH BACK PACK

BLED2x1-BI-B

BLED2x1-BI-B 3 Light Kit	Bicolor - Basic (2x DLED4/1x Felloni) AC, mains operation only
2 DLED4-BI	dedolight focusing LED light head, bicolor
2 DT4-BI	AC power supply for DLED4 bicolor light heads
2 DPLS	Light shield ring
2 DBD8	Standard barn door (eight leaves)
1 TP-LONI3-BIHO	Felloni3 LED panel bicolor high output 45°
1 TP-SBX50	Felloni soft box 50x50cm
1 TP-SBXG50	Felloni textile grid for soft box
1 TP-OFFSET	Offset arm for Felloni when used with onboard batteries
3 DST	dedolight stands
1 DBPSLED	Backpack, small, with dividers for Felloni panel

Size: 60 x 50 x 30 cm (24 x 20 x 12")
Weight: 20.0 kg (44.1 lbs)

BLED2x1-D-B

BLED2x1-D-B 3 Light Kit	Daylight - Basic (2x DLED4/1x Felloni) AC, mains operation only
-----------------------------------	---

Same as BLED2x1-BI-B, but as 40 W daylight system with DLED4-D, DT4 power supplies and Felloni daylight panel instead of bicolor units.



BLED2x1-BI-S

BLED2x1-BI-S 3 Light Kit	Bicolor - Standard (2x DLED4/1x Felloni) AC, mains operation only
------------------------------------	---

(items in **bold** are in addition to **BASIC** kit)

2 DLED4-BI	dedolight focusing LED light head, bicolor
2 DT4-BI-BAT	Battery power supply for DLED4 bicolor light heads
2 DDCC-DTAPS	Short D-Tap cable, 28 cm (11")
2 DLPS12-60	12 V power supply, 60 W
2 DPLS	Light shield ring
2 DBD8	Standard barn door (eight leaves)
1 DP1.1	Imager projection attachment
1 DPGH	Steel gobo holder (size ,M')
1 DPGSET	Gobo set (six popular steel gobos, size ,M')
2 DFH	Gel filter holder
1 DGW	Gel filter set, warm tone (fits DFH filter holder)
1 DGMD	Gel filter set, mixed diffusion (fits DFH filter holder)
1 DGCOL	Gel filter set, color effect (fits DFH filter holder)
1 TP-LONI3-BIHO	Felloni3 LED panel bicolor high output 45°
1 TP-SBX50	Felloni soft box 50x50cm
1 TP-SBXG50	Felloni textile grid for soft box
1 TP-OFFSET	Offset arm for Felloni when used with onboard batteries
3 DST	dedolight stands
1 DH2	Wall holder
1 CLAMP1	dedolight clamp
1 DBPSLED	Backpack, small, with dividers for Felloni panel

Size: 60 x 50 x 30 cm (24 x 20 x 12")
Weight: 16.6 kg (36.6 lbs)

BLED2x1-D-S

BLED2x1-D-S 3 Light Kit	Daylight - Standard (2x DLED4/1x Felloni) AC, mains operation only
-----------------------------------	--

Same as BLED2x1-BI-S, but as 40 W daylight system with DLED4-D, DT4-BAT power supplies and Felloni daylight panel instead of bicolor units.



DLED4/FELLONI (2x2) 4 LIGHT KIT - WITH SOFT CASE

SLED2x2-BI-B

■ SLED2x2-BI-B 4 Light Kit	Bicolor - Basic (2x DLED4/2x Felloni) AC, mains operation only
2 DLED4-BI	dedolight focusing LED light head, bicolor
2 DT4-BI	AC power supply for DLED4 bicolor light heads
2 DPLS	Light shield ring
2 DBD8	Standard barn door (eight leaves)
1 DP1.1	Imager projection attachment
1 DPGH	Steel gobo holder (size ,M')
1 DPGSET	Gobo set (six popular steel gobos, size ,M')
1 DPACP	Accessory Pouch
2 TP-LONI3-BIHO	Felloni3 LED panel bicolor high output 45°
2 TP-SBX50	Felloni soft box 50x50cm
2 TP-SBXG50	Felloni textile grid for soft box
1 TPOFFSET	Offset arm for Felloni when used with onboard batteries
1 DSCLED2x2	Soft case for 2x Felloni / 2x DLED4
1 SDST4	Stand kit with 4x DST and soft bag
Size DSCLED2x2:	56 x 48 x 32 cm (22" x 18.9" x 12.6")
Weight:	16.8 kg (37 lbs)
Size SDST4:	55 x 17 x 18 cm (21.7 x 6.7 x 7.1")
Weight:	4.2 kg (9.3 lbs)

SLED2x2-D-B

■ SLED2x2-D-B 4 Light Kit	Daylight - Basic (2x DLED4/2x Felloni) AC, mains operation only
Same as SLED2x2-BI-B, but as 40 W daylight system with DLED4-D, DT4 power supplies and Felloni daylight panels instead of bicolor units.	



SLED2x2-BI-M

■ SLED2x2-BI-M 4 Light Kit	Bicolor - Master (2x DLED4/2x Felloni) AC/DC, mains and battery operation
(items in bold are in addition to BASIC kit)	
2 DLED4-BI	dedolight focusing LED light head, bicolor
2 DT4-BI	AC power supply for DLED4 bicolor light heads
2 DPLS	Light shield ring
2 DBD8	Standard barn door (eight leaves)
1 DP1.1	Imager projection attachment
1 DPGH	Steel gobo holder (size ,M')
1 DPGSET	Gobo set (six popular steel gobos, size ,M')
1 DPACP	Accessory Pouch
2 TP-LONI3-BIHO	Felloni3 LED panel bicolor high output 45°
2 TP-SBX50	Felloni soft box 50x50cm
2 TP-SBXG50	Felloni textile grid for soft box
1 TPOFFSET	Offset arm for Felloni when used with onboard batteries
1 DSCLED2x2	Soft case for 2x Felloni / 2x DLED4
1 SDST4	Stand kit with 4x DST and soft bag
2 DT4-BI-BAT	Battery power supply for DLED4 bicolor light heads
2 DDCC-DTAPS	Short D-Tap cable, 28 cm (11")
2 DIPS12-60	12 V power supply, 60 W
4 DS-95SI	14,4V batteries with internal charger and charge cable
2 DLBCA2-V	Belt adapter for V-Mount batteries with holding plate for DT4(-BI)-BAT power supplies. D-Tap power out socket.
2 DFH	Gel filter holder
1 DGW	Gel filter set, warm tone (fits DFH filter holder)
1 DGMD	Gel filter set, mixed diffusion (fits DFH filter holder)
1 DGCOL	Gel filter set, color effect (fits DFH filter holder)
1 DSCS	Soft case, small

SLED2x2-D-M

■ SLED2x2-D-M 4 Light Kit	Daylight - Master (2x DLED4/2x Felloni) AC/DC, mains and battery operation
Same as SLED2x2-BI-M, but as 40 W daylight system with DLED4-D, DT4, DT4-BAT power supplies and Felloni daylight panels instead of bicolor units.	
Size DSCLED2x2:	56 x 48 x 32 cm (22" x 18.9" x 12.6")
Weight:	16.8 kg (37 lbs)
Size SDST4:	55 x 17 x 18 cm (21.7 x 6.7 x 7.1")
Weight:	4.2 kg (9.3 lbs)
Size DSCS:	53 x 24 x 23 (20.9" x 9.5" x 9.1")
Weight:	8.4 kg (18.5 lbs)



DLED4 3 LIGHT KIT – WITH SOFT CASE

SLED3-BI-B

SLED3-BI-B 3 Light Kit

Bicolor - Basic
mains operation only

3	DLED4-BI	dedolight focusing LED light head, bicolor
3	DT4-BI	AC Power supply for DLED4 bicolor light heads
3	DPLS	Light shield ring
3	DBD8	Standard barn door (eight leaves)
1	DLSR70	Speed ring for Classic Series and DLED4 light heads
1	DSBSXS	dedoflex mini soft box - 30x30x23cm (12x12x9")
1	DLGRIDXS	Grid (40°), fits mini soft box
3	DST	dedolight stands
1	DSC1	Soft case small

Size: 65 x 24 x 36 cm (25.6 x 9.5 x 14.2")
Weight: 13.7 kg (30.2 lbs)

SLED3-D-B

SLED3-D-B 3 Light Kit

Daylight - Basic
mains operation only

Same as SLED3-BI-B, but as 40 W daylight system with DLED4-D and DT4 power supplies instead of bicolor units.



SLED3-BI-M

SLED3-BI-M 3 Light Kit

Bicolor - Master
AC/DC, mains and battery operation

(items in **bold** are in addition to **BASIC** kit)

3	DLED4-BI	dedolight focusing LED light head, bicolor
3	DT4-BI-BAT	Battery power supply for DLED4 bicolor light heads with Kelvin display
3	DDCC-DTAPS	Short D-Tap cable, 28 cm (11")
3	DLPS12-60	12 V power supply, 60 W
3	DPLS	Light shield ring
3	DBD8	Standard barn door (eight leaves)
1	DLSR70	Speed ring for Classic Series and DLED4 light heads
1	DSBSXS	dedoflex mini soft box - 30x30x23cm (12x12x9")
1	DLGRIDXS	Grid (40°), fits mini soft box
1	DP1.1	Imager projection attachment
1	DPGH	Steel gobo holder (size ,M')
1	DPGSET	Gobo set (six popular steel gobos, size ,M')
1	DFXSET	Set of three structur glass filters with holders DFXT6-R / DFXT10-LB / DFXT11-P
1	DPACP	Accessory pouch
3	DFH	Gel filter holder
1	DGW	Gel filter set, warm tone (fits DFH filter holder)
1	DGMD	Gel filter set, mixed diffusion (fits DFH filter holder)
1	DGCOL	Gel filter set, color effect (fits DFH filter holder)
3	DS-95SI	14,4V batteries with internal charger and charge cable
3	DLBCA2-V	Belt adapter for V-Mount batteries with holding plate for DT4-(BI)-BAT power supplies. D-Tap power out socket.
3	DST	dedolight stands
1	DSC2	Soft case medium

Size: 83 x 30 x 33 cm (32.7 x 11.8 x 13")
Weight: 21.5 kg (47.4 lbs)

SLED3-D-M

SLED3-D-M 3 Light Kit

Daylight - Master
AC/DC, mains and battery operation

Same as SLED3-BI-M, but as 40 W daylight system with DLED4-D, DT4 and DT4-BAT power supplies instead of bicolor units.



DLED4 4 LIGHT KIT – WITH SOFT CASE

SLED4-BI-B

■ SLED4-BI-B 4 Light Kit		Bicolor - Basic AC, mains operation only
4	DLED4-BI	dedolight focusing LED light head, bicolor
4	DT4-BI	AC Power supply for DLED4 bicolor light heads
4	DPLS	Light shield ring
4	DBD8	Standard barn door (eight leaves)
2	DLSR70	Speed ring for Classic Series and DLED4 light heads
2	DSBSXS	dedoflex mini soft box - 30x30x23cm (12x12x9")
2	DLGRIDXS	Grid (40°), fits mini soft box
1	DP1.1	Imager projection attachment
1	DPGH	Steel gobo holder (size ,M')
1	DPGSET	Gobo set (six popular steel gobos, size ,M')
1	DH2	wall holder
1	CLAMP1	dedolight clamp
4	DST	dedolight stands
1	DSC2	Soft case medium
Size:		83 x 30 x 33 cm (32.7 x 11.8 x 13")
Weight:		19.9 kg (43.9 lbs)

SLED4-D-B

■ SLED4-D-B 4 Light Kit		Daylight - Basic AC, mains operation only
Same as above, but as 40 W daylight system with DLED4-D and DT4 power supplies instead of bicolor units.		



SLED4-BI-M

■ SLED4-BI-M 4 Light Kit		Bicolor - Master AC/DC, mains and battery operation
(items in bold are in addition to BASIC kit)		
4	DLED4-BI	dedolight focusing LED light head, bicolor
4	DT4-BI-BAT	Battery power supply for DLED4 bicolor light heads with Kelvin display
4	DDCC-DTAPS	Short D-Tap cable, 28 cm (11")
4	DLPS12-60	12 V power supply, 60 W
4	DPLS	Light shield ring
4	DBD8	Standard barn door (eight leaves)
2	DLSR70	Speed ring for Classic Series and DLED4 light heads
2	DSBSXS	dedoflex mini soft box - 30x30x23cm (12x12x9")
2	DLGRIDXS	Grid (40°), fits mini soft box
1	DP1.1	Imager projection attachment
1	DPGH	Steel gobo holder (size ,M')
1	DPGSET	Gobo set (six popular steel gobos, size ,M')
1	DFXSET	Set of three structur glass filters with holders DFXT6-R / DFXT10-LB / DFXT11-P
1	DPACP	Accessory pouch
4	DFH	Gel filter holder
1	DGW	Gel filter set, warm tone (fits DFH filter holder)
1	DGMD	Gel filter set, mixed diffusion (fits DFH filter holder)
1	DGCOL	Gel filter set, color effect (fits DFH filter holder)
4	DS-95SI	14,4V batteries with internal charger and charge cable
4	DLBCA2-V	Belt adapter for V-Mount batteries with holding plate for DT4(-BI)-BAT power supplies. D-Tap power out socket.
1	DH2	Wall holder
1	CLAMP1	dedolight clamp
4	DST	dedolight stands
1	DSCXLW	Soft case large, with wheels
Size:		94 x 30 x 38 cm (37 x 11.8 x 14.9")
Weight:		26.8 kg (59.1 lbs)

SLED4-D-M

■ SLED4-D-M 4 Light Kit		Daylight - Master AC/DC, mains and battery operation
Same as SLED4-BI-M, but as 40 W daylight system with DLED4-D, DT4, DT4-BAT power supplies instead of bicolor units.		



DLED9 LED LIGHT HEAD ASPHERICS²® OPTICS



The exceptional dedolight DLED9 combines the unique dedolight double aspheric optical system with state-of-the-art dedocolor® LED light sources. This light head is available in daylight, tungsten and a tunable bicolor version. Accepts all of the accessories and projection attachment/imagers which are identical to the ones in our Series 400 lighting fixtures (DLH400DT and DLH650).

The DLED9 offers an astounding focusing range, excellent light and color distribution, with perfect color rendering qualities.

The power supply for this light works with all voltages from 90 - 264 V AC, and it allows continuous dimming without any color change.



For studio use, a pole-operated version is available and/or DMX controlled. For mobile use, this light comes with separate ballast.

NEW (in separate catalog)

- DLED10, our new powerful flagship light, daylight or bicolor, mobile or studio.
- DLED30, our most powerful LED studio light



DLED9 TECHNICAL DATA

DLED9-D

DLED9-T

DLED9-BI

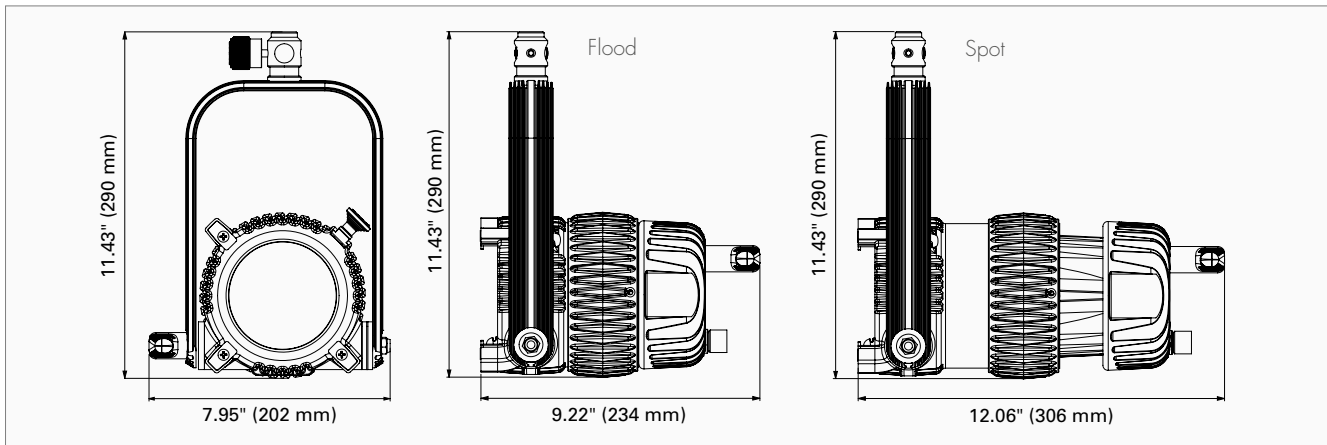

FOCUSING LED LIGHT HEAD: DLED9-D, DLED9-T, DLED9-BI

Focus Range (Intensity Range)	50-4° (1:12) with optional aspheric wide-angle attachment: 75°-44°
Focus Control	Two complete turns on focus ring
Power	90W
Mounting	5/8" (16 mm) receptacle and 1 1/8" (28 mm) stud
Operating Position	Any
Tilt Control	Permanent friction
Accessory Holder	Ø 5.1" (129 mm)
Safety	Protection Class III, SELV, IP40
Cooling	Passive cooling (no fan)
UV	No UV radiation
Weight	8.2 lb (3,700 g)
Size	W: 7.95" (202 mm) L (flood): 9.22" (234 mm) L (spot): 12.06" (306 mm) H: 11.43" (290 mm)

DLED9-D Focusing LED Light Head. Daylight approx. 5600K

Distance	Meter	1	2	3	4	5	10
	Feet	3'	6'	9'	12'	15'	30'
Flood	Lux	5,080	1,270	565	318	203	51
	Foot Candle	472	118	53	30	19	5
Medium	Lux	6,600	1,650	733	413	264	66
	Foot Candle	613	153	68	38	25	5.6
Spot	Lux	60,000	15,000	6,666	3,750	2,400	600
	Foot Candle	5,576	1,394	620	349	223	56

DLED9-T Focusing LED Light Head. Tungsten approx. 3200K

Distance	Meter	1	2	3	4	5	10
	Feet	3'	6'	9'	12'	15'	30'
Flood	Lux	3,860	965	429	241	154	39
	Foot Candle	359	90	40	22	14	4
Medium	Lux	5,680	1,420	631	355	227	57
	Foot Candle	528	132	59	33	21	5.3
Spot	Lux	40,800	10,200	4,533	2,550	1,632	408
	Foot Candle	3,792	948	421	237	152	38

DLED9-BI Focusing LED Light Head. Bicolor measured at 5600K – daylight

Color temperature continuously adjustable from 2700 – 6500K

Distance	Meter	1	2	3	4	5	10
	Feet	3'	6'	9'	12'	15'	30'
Flood	Lux	5,050	1,263	561	316	202	50
	Foot Candle	469	117	52	29	19	4.7
Medium	Lux	6,565	1,591	729	410	263	65
	Foot Candle	610	153	68	38	24	6
Spot	Lux	43,000	10,750	4,777	2,688	1,720	430
	Foot Candle	3,996	999	444	250	160	40

Bicolor in tungsten function ~ 25 % lower output

AC POWER OPTIONS FOR DLED9

DT9 – AC power supply for DLED9 tungsten and daylight light heads.

DT9-BI – AC power supply for DLED9-BI bicolor light head

Allows worldwide use from 90V-264V AC* 50/60Hz

Continuous dimming with unique dedolight dimming algorithms allow smooth dimming, even at the low end

Add suffix “-DMX” for above ballasts with DMX control (DT9-DMX)

Battery power supplies for DLED9 light heads with 11-36V DC power input.

DAYLIGHT / TUNGSTEN

DT9

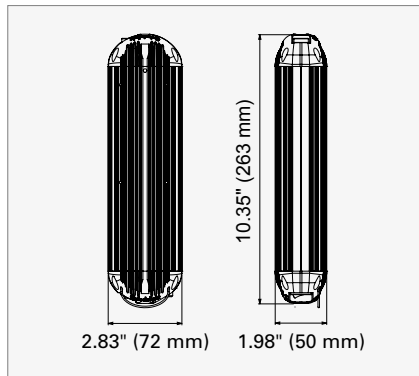

BICOLOR

DT9-BI

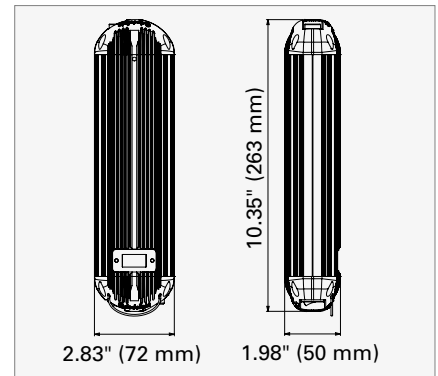

DT9-DMX

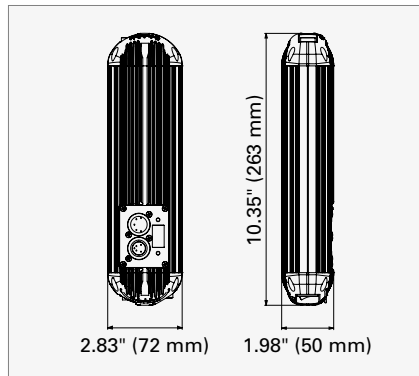

DT9-BI-DMX

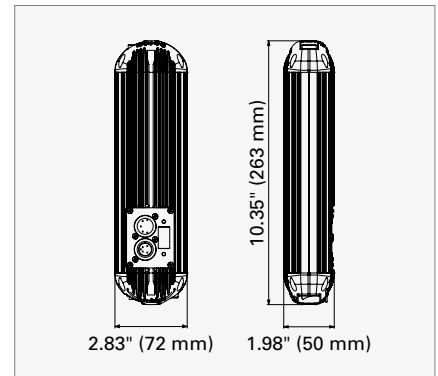

POWER SUPPLY FOR AC OPERATION: DT9, DT9-BI

Input Voltage	90 - 264 V AC * 100 VA / 1 - 0.4 A 90 W
Output Voltage	40 V
Controls	ON/OFF switch, dimming knob
Dimming	Continuously from 100-0%
Safety	Protection Class I, IP40
Cable length (plug -> power supply)	Mains cable 8.2' / 2.5 m
Cable length (plug -> light head)	Cable to light head 4.6' / 1.4 m
Mounting	Cable loop
Weight	3.1 lb (1,400 g)

*.) functional range including tolerances

DTHC

€ 73,50

ballast holder to mount LED ballasts to lighting stands. Max. opening 25,4 mm (1")



DLED9SE for Pole-Operation with DMX

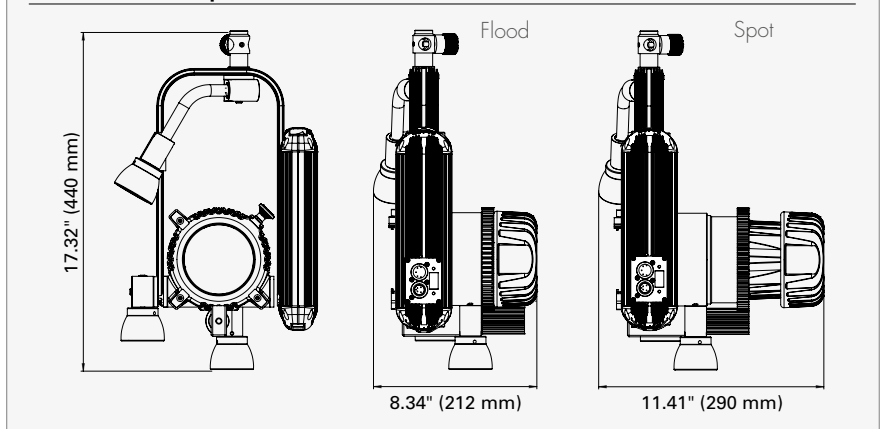

AC/DC POWER OPTIONS FOR DLED9

NEW DT9-BAT-AB / DT9-BI-BAT-AB POWER SUPPLY FOR AC/DC USE

DT9-BAT-AB

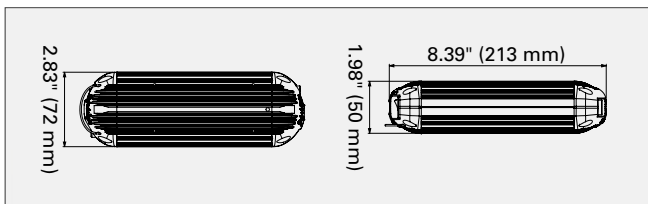

DT9-BI-BAT-AB

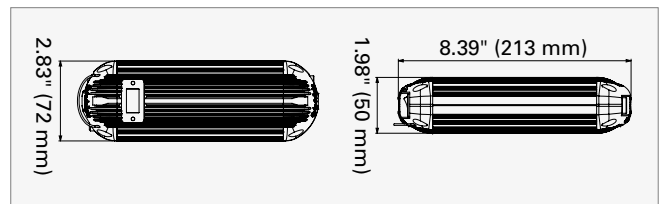

DC USE WITH DT9-(BI-)BAT-AB



DT9-BI-BAT-AB

power supply with 28 cm (11") D-Tap cable

option:

DLBCA2-V

belt clip for V-Mount batteries

DS-95SI

14,4 V battery, 95 Wh

DDCC-XLR

adapter cable to 4-pin XLR

DDCC-CAR

adapter cable to car cigarette lighter

AC USE WITH DT9-(BI-)BAT-AB



DLP536-100

Mains Power Supply with D-Tap connector 100W – 36V
Feeds power to both: DT9-BI-BAT-AB as well as to the mono-color DT9-BAT-AB

DT9-BAT-AB

power supply with 28 cm (11") D-Tap cable



option:

DDTAP-EXT5

5 m (16.4') D-Tap extension cable

€ 29,00

DLED12 DMX STUDIO EDITION

The DLED12 DMX was our largest fixture in our range of focusing LED lights.

In a separate brochure you now find information about an even more powerful studio light, the DLED30, which outperforms the DLED12 and also many other lights of our competitors.

The extreme power of this light is compensated by a state-of-the-art cooling system – keeping noise at an extremely low level, important for studio application.

Noise level of our cooling system is distinctly lower than with other comparable lights.

dedolight aspherics2 optics provide the expected huge focusing range, clean beam and smooth light distribution.

All versions are available in daylight, tungsten and bicolor. Pole operation is optional.



DLED12 DMX TECHNICAL DATA

DLED12-D-DMX

DLED12-T-DMX

DLED12-BI-DMX

Pole-Operated Versions (n.s.):

DLED12-D-PO-DMX

DLED12-T-PO-DMX

DLED12-BI-PO-DMX

**FOCUSING LED LIGHT HEAD:
DLED12-D/-T/-BI-DMX**

Focus Range (Intensity Range)	DLED12-BI-DMX: 60°-5° (1:1.1) DLED12-D-DMX: 65°-8° (1:8) DLED12-T-DMX: 65°-8° (1:6) with optional aspheric wide-angle attachment: 85°-54°
Focus Control	Focus control on back
Dimming	Continuously from 100-0%
Power	90-264V AC * 240VA / 2.4·1A 250W
Mounting	5/8" (16 mm) receptacle and 1 1/8" (28 mm) stud
Operating Position	+/- 90° (from horizontal)
Tilt Control	Adjustable friction
Accessory Holder	Ø 6.6" (169 mm)
Safety	Protection Class I, IP40
Cooling	Active heat pipe cooling with super quiet fan system
UV	No UV radiation
Weight	11,000 g (25 lb)
Size	W: 12.73" (323.37 mm) L: 19.06" (484, 14 mm) H: 21.36" (542.63 mm)

*) functional range including tolerances

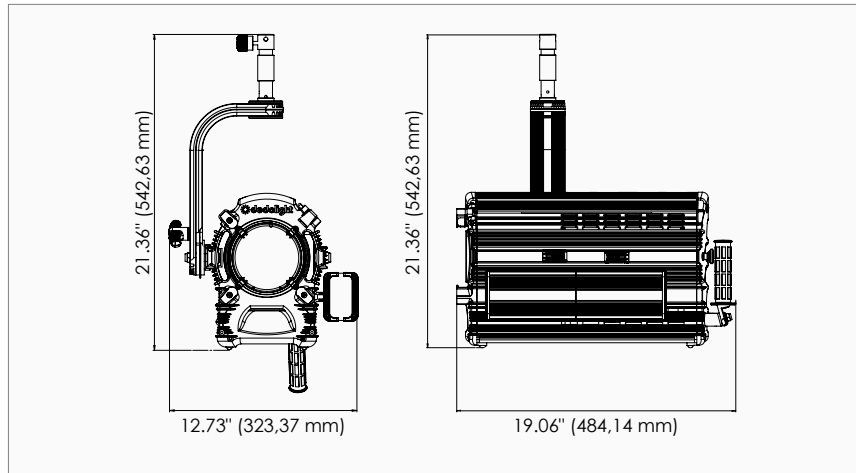

DLED12-D-DMX Focusing LED Light Head. Daylight approx. 5600K

Distance	Meter	1	2	3	5	10	15
	Feet	3'	6'	9'	15'	30'	45'
Flood	Lux	11,250	2,813	1,250	450	113	50
	Foot Candle	1,046	261	116	42	11	4.6
Medium	Lux	26,000	6,500	2,888	1,040	260	116
	Foot Candle	2,416	604	268	97	24	11
Spot	Lux	94,500	23,625	10,500	3,780	945	420
	Foot Candle	8,783	2,196	976	351	88	39

DLED12-T-DMX Focusing LED Light Head. Tungsten approx. 3200K

Distance	Meter	1	2	3	5	10	15
	Feet	3'	6'	9'	15'	30'	45'
Flood	Lux	9,090	2,273	1,010	364	91	40
	Foot Candle	845	211	94	34	8.5	3.7
Medium	Lux	18,180	4,545	2,020	727	182	81
	Foot Candle	1,690	422	188	68	17	8
Spot	Lux	52,000	18,700	8,311	2,992	748	332
	Foot Candle	4,833	1,738	771	278	70	31

DLED12-BI-DMX Focusing LED Light Head. Bicolor measured at 5600K – daylight

Color temperature continuously adjustable from 2700 – 6500K

Distance	Meter	1	2	3	5	10	15
	Feet	3'	6'	9'	15'	30'	45'
Flood	Lux	8,400	2,100	933	336	84	37
	Foot Candle	780	195	87	31	8	3.4
Medium	Lux	20,800	5,200	2,310	832	208	93
	Foot Candle	1,933	483	215	77	19	9
Spot	Lux	90,900	22,725	10,100	3,636	909	404
	Foot Candle	8,448	2,112	939	338	85	38

Bicolor in tungsten function ~ 17% lower output

LED MINI ON BOARD-LIGHT – NEXT GENERATION



DLOBML2 Daylight

- Amazing output in combination with dedolight double aspheric optics.
- Focuses like a dedolight. LED lights are usually not focusable.
- No other focusing LED light compares - 4° to 56°.
- Smooth light distribution in all and every focusing position.
- Now with flip-up, wide-angle effect glass for wide, horizontal spread with gentle flowing edges. Ideal for on-board work when several people are close to the camera.
- Converts from daylight to tungsten
- Powers from any 6V to 18V DC power source.
- Optional battery shoes are available for Sony, Panasonic, Canon and Nikon mini-DV batteries.
- NPF550 7.2V, 2000 mA, 105 minute run time.
- NPF750 7.2V, 4000 mA, 210 minute run time.
- NPF950 7.2V, 6000 mA, 330 minute run time.
- When dimmed to 50% light output, power consumption drops accordingly resulting in twice the run time.

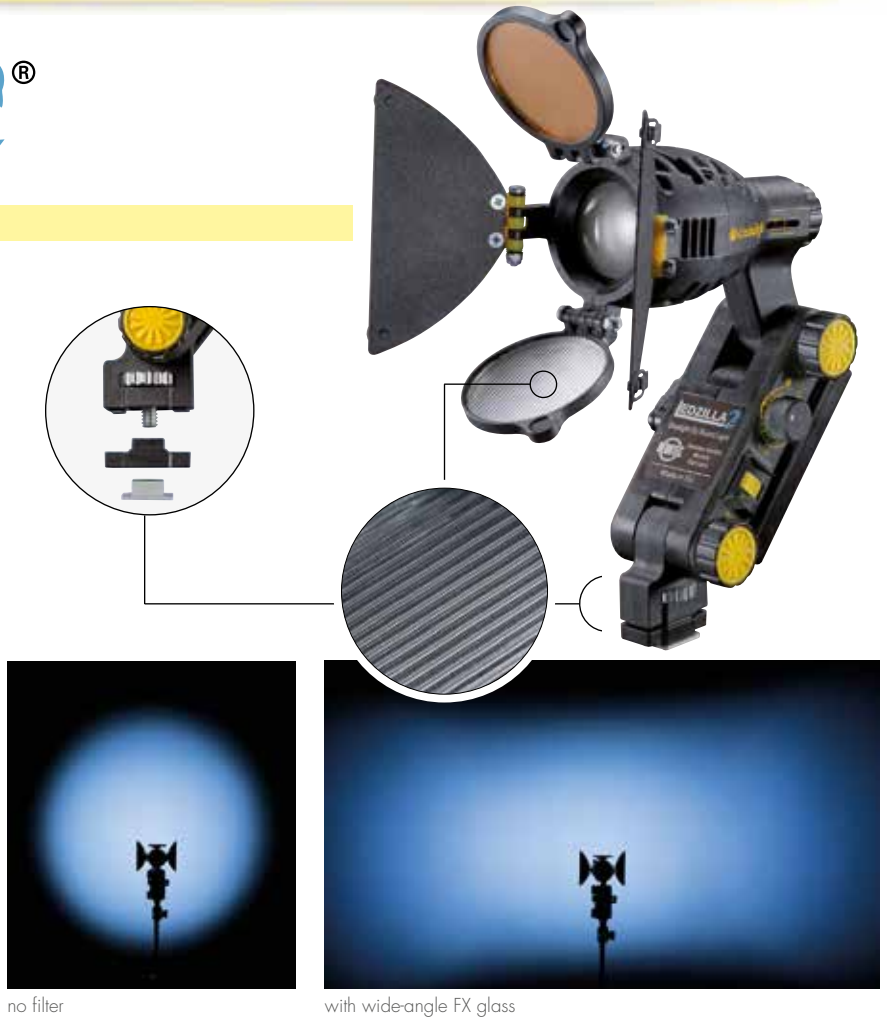

no filter

with wide-angle FX glass

- Alternative power from any Anton/Bauer or PAG system, V-Lock battery, car cigarette lighter output or battery belt.
- Power consumption is only 8W despite its high output.
- Operates from -40°C up to +40°C.
- LED power available indicator.
- Front-end bayonet mount allows the addition of attachments and light modifiers.

DLOBML2 LED Mini On-Board Light daylight 5600K							
Distance	Meter	1	2	3	4	5	10
	Feet	3'	6'	9'	12'	15'	30'
Flood	Lux	435	109	48			
	Foot Candle	40	10	4.5			
Medium	Lux	957	239	106	60		
	Foot Candle	89	22	9.9	5.6		
Spot	Lux	5,400	1,350	600	338	216	54
	Foot Candle	502	126	56	31	20	5

Option only for Ledzilla2:

Attach by front end bayonet mount



DLOBML-SBX12-CTO Front diffuser

Interchangeable front diffuser with color conversion to 3200K for Ledzilla soft box (DLOBML-SBX12)

LEDZILLA BICOLOR – LED MINI ON BOARD-LIGHT



DLOBML-BI Bicolor

Version without the flip-up wide-angle optics, but with 8-leaf barn door

DLOBML-BIWA Ledzilla bicolor WA

The Ledzilla bicolor has 2 barn door leaves and the 'flip-up' wide-angle optics – see also explanations on page 28.

- Color temperature can be adjusted in a very wide range, from 2700K all the way to 6500K. This light may be adjusted to all ambient light situations.
- Most LED Bicolor lights have only half the light out when set to daylight or tungsten. The Ledzilla Bicolor utilizes an LED array which produces a full 8 W in both daylight and tungsten positions.
- In a Bicolor LED light, the tungsten position is generally 25-30% weaker than in daylight. The multichip light source of the Bicolor Ledzilla utilizes 9 mini-chips arranged in a checkerboard pattern. We use 5 chips in the tungsten position and 4 chips in the daylight position. This results in a nearly equal light output in both daylight and tungsten positions.
- Regardless of the settings of the color temperature, the light output is smoothly dimmable all the way down to full zero, without any 'digital' steps.
- A bayonet attachment allows the interchangeability of the front optical elements with front-end accessories, like the soft box, the China lantern and the soft tube
- All the power options are identical with the options described for the Ledzilla2.
- The Ledzilla Bicolor features perfect color values. In daylight – CRI92, in tungsten setting – CRI97 (TLCI).



DLOBML-BI Ledzilla Bicolor as measured in daylight position 5600K

Distance	Meter	1	2	3	4	5	10
	Feet	3'	6'	9'	12'	15'	30'
Flood	Lux	330	83	37			
	Foot Candle	31	7.7	3.4			
Medium	Lux	726	182	81	45		
	Foot Candle	67	17	7.5	4.2		
Spot	Lux	2,650	663	294	166	106	
	Foot Candle	246	62	27	15	9.9	

Bicolor in tungsten function ~ 15% lower output

Options for Ledzilla2 and Bicolor: Soft-Tube, Soft Box, White Dome

Attach by front end bayonet mount



DLOBML-SBX12 Soft box

5"/12 cm wide – Gentle fill light, easy to look at, ideal for close ups. Filter slot accepts tungsten conversion filter.



DLOBML-WD15 White dome

5.9"/15 x 15 cm (china lantern) soft box, gentle light, evenly distributed, perfect as general fill light. Side covers can be opened individually.



DLOBML-LT20 Soft tube

8"/20 cm long – Ideal for soft light in confined areas, e.g., car interior at night. Detachable light shaper – folding plastic barn doors.

MOUNTING & ACCESSORIES

(FOR LEDZILLA®, IREDZILLA, FLUORESZILLA)

Camera Adapter

DLA-LB

Large bone
2 x female camera
shoes and 3 x 1/4"
threads.
Mounts to camera
with 1/4" screw



DLGA300

Articulating arm 300 mm,
square top with 1/4" thread,
camera shoe
or 1/4" screw to camera



DLGA200

Articulating arm 200 mm,
square top with 1/4"
thread, camera shoe or
1/4" screw to camera



DLBSA-MBJ

Metal ball joint,
square top with
1/4" thread and
camera shoe



DLBSA-U

Square top with
1/4" thread,
ends in camera shoe



DLBSA-3S

Triple female
camera shoe
with tilt lock



Stand Adapter

DLA-ML

Stand adapter,
square top with 1/4"
thread accepts 16 mm
baby stud (5/8")



DLBSA-JSF

Stand adapter,
camera shoe accepts
16 mm baby stud (5/8")



Stand Alone

DLBSA-TS

Table support
9.5 x 6.3 x 1.2 cm
(3.7" x 2.5" x 0.5"),
accepts camera shoe



DLBSA-HAND

Handle with female
camera shoe



DLBR5

Rail with 1/4" screw
for camera and
female camera
shoe for light head



DLBRHS

Rail with folding handle
1/4" screw for camera
and female camera shoe
for light head



DV3GA

Vacuum mount
Ø 7,5 cm / 3"
with 200 mm
articulating arm



Transport Pouch

DLOBML-P

Soft pouch for
Ledzilla LED
light head



POWER SUPPLY

(FOR LEDZILLA[®], IREDZILLA, FLUORESZILLA)

Battery Holder Plates

DLOBML-BS

for 7.2 V Sony for NP-F / Panasonic VW-VBD1

DLOBML-BSV

for 7.2 V Sony NP-FV

DLOBML-BSU

for 12 V Sony for BP-U

DLOBML-BP

for 7.2 V Panasonic for CGA

DLOBML-BP2

for 7.2 V Panasonic for VW-VBG6

DLOBML-BP3

for 7.2 V Panasonic for VW-VBG 070 / 130/260, CGA-DU07/14/21

DLOBML-BP4

for 7.2 V Panasonic VW-VDB 58

DLOBML-BC

for 7.2 V Canon for BP-9

DLOBML-BC2

for 7.2 V Canon for BP 808 / 809 / 819

Photo Battery Shoe:

DLOBML-PBC1

for 7.2 V Canon for LP-E6

DLOBML-PBN1

for 7.2 V Nikon for EN-EL3E

DLOBML-PBN2

for 7.2 V Nikon for EN-EL15

DLOBML-PBP1

for 7.2 V Panasonic for DMW-BLF19E

Batteries

DLB-NPF550

7.4 V Li-Ion battery
14.8 Wh (2000 mAh)



DLB-NPF950

7.4 V Li-Ion battery
43.2 Wh (6000 mAh)



Batteries

DLCH-NPF

NPF-Battery
Charger
Input: 100-240V



DLBF-8AA

External battery box
for 8 AA batteries
1.5 V



Power Cable

DLPS-12

100-240V
with 12V DC
1500 mA,
18 W
output



Belt Adapter

DLBCA-NPF

NPF Adapter
Belt holder
with Velcro
loop to carry
NPF battery
on a belt



DLBCA-V

V-Mount belt adapter
without ballast holder,
separate extension cable
to light head needed



DLBCA-AB

Anton/Bauer-Mount belt
adapter without ballast
holder, separate extension
cable to light head needed



Battery Cables

DDCC-DTAPS

Cable 28 cm / 11" with
D-Tap connector



DDCC-DTAPL

Cable 55 cm / 22" with
D-Tap connector



DDCC-SWIT

Swit Cable 55 cm / 22"
with Ø 2,1 / 5,5 mm connector
for Swit battery



DDCC-PAG

PAG Cable 55 cm / 22"
with Ø 2,1 / 5,5 mm connector
for PAG battery



DDCC-XLR

65 cm - 1,30 m /
25 - 51"
with 4-Pin XLR connector



DDCC-CAR

Cable 1,8 m (6 ft.)
with cigarette light
connector





DLOBML-IR860 860 nm Infrared LED

Works with cameras having a night-shot function such as Somikon DV-883IR, Sony HDR-XR550/HDR-CX730E/DCR-TRV355E/PMW-100 and Canon XA10/XA20/XA25.

DLOBML-IR960 960 nm Infrared LED

Works with special night-vision surveillance cameras.

DLOBML-BI-R 860/960nm Infrared LED

- World's first focusing near infrared illuminator that focuses like a dedolight.
- With focusing range of 4° to 56°

- Even light distribution in all focusing positions.
- Dimmable down to 5%.
- Illumination up to 40 m (130 ft) (tested with Sony Nightshot Camcorder)
- Powers from any 6V to 18V DC power source.
- Power consumption is only 6W
- Operates from -40°C up to +40°C.
- Various power cable and mounting accessories are available
- Works with most night vision equipment
- Optional battery shoe for Panasonic, Sony, Canon and Nikon 7.2 V Li-Ion batteries
- NPF550 7.2V, 2000 mA, 105 minute run time.
- NPF750 7.2V, 4000 mA, 210 minute run time.
- NPF950 7.2V, 6000 mA, 330 minute run time.
- Optional power cables are available for Anton/Bauer and PAG systems, car cigarette lighter outputs or battery belts/packs
- The light projected from an 860 nm infrared LED is invisible to the human eye, however you may see a dull red glow when looking

directly at the front lens. Also available in a 960 nm version (completely invisible for special IR-Sensor)

- Applications:
 - Infrared Illumination for cameras (night shot)
 - Infrared photography
 - Surveillance systems
 - Machine vision systems
 - Wildlife observation
 - Criminology



Mono-color	Spot 1m 5°	Flood 1m 55°
------------	------------	--------------

DLOBML-IR860	100 mW/cm ²	17 mW/cm ²
--------------	------------------------	-----------------------

DLOBML-IR960	90 mW/cm ²	15 mW/cm ²
--------------	-----------------------	-----------------------

Bicolor	Spot 1m 5°	Flood 1m 55°
---------	------------	--------------

DLOBML-BI-IR860	110 mW/cm ²	10 mW/cm ²
-----------------	------------------------	-----------------------

DLOBML-BI-IR960	100 mW/cm ²	9 mW/cm ²
-----------------	------------------------	----------------------

FLUORES-ZILLA



DLOBML-UV400 UV 400 nm LED

DLOBML-UV365 UV 365 nm LED

DLOBML-BI-UV365/400 nm

turnable ultraviolet Ledzilla

- Amazing light output with dedolight double aspheric optics
- Worldwide first black light source that focuses like a dedolight from 4° to 56°
- No heat emission in exiting rays

- No other focusing long-wave 400 nm UV-A LED light source has comparable focus range
- Perfectly even light distribution in each focus position
- Extremely gentle dimming from full intensity to 5% without change of color
- Power supply from 6V – 18V DC
- Power consumption, 6W
- Operating from -40°C to +40°C
- LED power indicator
- Optional battery shoe for Sony, Panasonic, Canon and Nikon 7.2 V Li-Ion batteries.
- NPF550 7.2V, 2000 mA, 105 min. run time
- NPF750 7.2V, 4000 mA, 210 min. run time
- NPF950 7.2V, 6000 mA, 330 min. run time
- When dimmed to 50%, power consumption is lowered accordingly, resulting in twice the run time.
- Alternative power supply from Anton/Bauer or PAG system, cigarette lighter adapter or battery belt.
- In comparison to 365nm LEDs Fluoreszilla

with 400 nm LED shows higher percentage of violet. Many materials reacting to fluorescent light appear in double brightness.

- Fields of application:
 - Black light effect / UV-active body paint
 - UV-active deco material
 - Magic ink / Edding UV-marker
 - Fluorescent wall paint (paintings)
 - Bank note – document testing
 - Mineralogy
 - Criminology

Mono-color	Spot 1m 5°	Flood 1m 55°
------------	------------	--------------

DLOBML-UV400	130 mW/cm ²	10 mW/cm ²
--------------	------------------------	-----------------------

DLOBML-UV365	280 mW/cm ²	17 mW/cm ²
--------------	------------------------	-----------------------

Bicolor	Spot 1m 5°	Flood 1m 55°
---------	------------	--------------

DLOBML-BI-UV365	170 mW/cm ²	12 mW/cm ²
-----------------	------------------------	-----------------------

DLOBML-BI-UV400	230 mW/cm ²	17 mW/cm ²
-----------------	------------------------	-----------------------

DLED – UV AND IR LED SPECIAL LIGHT HEADS

DLED2 Special – Infrared



DLED2-IR960

DLED2-IR860

INFRARED

- **DLED2Y-IR860** works at 860 nm and may be used on cameras with NIGHT SHOT / NIGHT VISION mode. The LED chip itself show red color when switched on
- **DLED2Y-IR960** works at 960 nm which is suitable for military cameras. The LED chip itself shows no visible light, even if switched on. Completely invisible light source.
- Separate **DT2-BAT-IR** and **DLED2POW** extension cables in three length available 55 cm (1.8'), 140 cm (4.6'), 300 cm (9.8')



- LED power indicator
- Mains power: DPLS12-30 universal AC power supply, 30 W
- Optional battery belt holder for Sony NPF 7.2 V Li-Ion batteries (DLBCA2-NPF)
- Compatible with DLED2 light shaping accessories

Mono-color	Spot 1m 5°	Flood 1m 55°
DLED2Y-IR860	320 mW/cm ²	35 mW/cm ²
DLED2Y-IR960	370 mW/cm ²	30 mW/cm ²

DLED4 Special – Infrared and UV



DLED4-IR860

DLED4-IR960

DLED4-BI-IR

INFRARED:

- 40 W IR LED comes in DLED4 housing
- DLED4-IR860 infrared LED for cameras with NIGHT SHOT / NIGHT VISION mode.



DLED4-UV365

DLED4-UV400

ULTRA-VIOLET („black light“):

40 W UV LED comes in two DLED4 versions:

- DLED4-UV365 works at 365 mn wavelength.
- DLED4-UV400 works at 400 mn wavelength.

INFRARED / ULTRA-VIOLET:

- AC and battery powered operation for all DLED4 IR / UV lights:
AC: DT4
DC: DT4-BAT and DDCC cable
- Compatible to DLED4/CLASSIC SERIES light shaping accessories

Mono-color	Spot 1m 5°	Flood 1m 60°
DLED4-UV400	1.175 mW/cm ²	73 mW/cm ²
DLED4-UV365	1.080 mW/cm ²	60 mW/cm ²

DLED9 Special – UV 400



DLED9-UV365

DLED9-UV400

ULTRA-VIOLET („black light“):

- 80 W DLED9-UV365 works at 365 mn wavelength.
- DLED9-UV400 works at 400 mn wavelength.
- AC and battery powered operation for all DLED9 UV lights:
AC: DT9 (see page 24)
DC: DT9-BAT-AB (see page 25)
- Compatible to DLED9/Series 400 light shaping accessories

400 nm

365 nm



Mono-color	Spot 1m 5°	Flood 1m 60°
DLED9-UV400	3.100 mW/cm ²	260 mW/cm ²
DLED9-UV365	3.600 mW/cm ²	260 mW/cm ²

- New optical elements provide highest light efficiency and reach with perfect color rendition and a pleasing ,human' light character.
- Even over a distance of 6 meters (20 ft) more than 700 lux at 220 W power consumption - most probably an unequalled light efficiency.
- Passive cooling: no fan – no noise
- Manual and DMX control included
- Amazing price/performance ratio

Other versions of Ledrama:

- Ledrama Large - size
120x40 cm (47" x 15.7")
Code: **DLEDRAMAL-D / DLEDRAMAL-BI**
- Ledrama Small - size
40x40 cm (15.7" x 15.7")
Code: **DLEDRAMAS-D / DLEDRAMAS-BI**

DLEDRAMA-D Daylight

Standard, 2,304 SMD-LEDs
Fixture Size 80x58 cm (31.5" x 22.8")

DLEDRAMA-BI Bicolor

Standard, 4,608 SMD-LEDs
Fixture Size 80x58 cm (31.5" x 22.8")

Amazing: The bicolor ledrama in daylight function offers identical light output and reach as the daylight light fixture. Every individual light source changes the color.

Technical Data: DLEDRAMA-D / DLEDRAMA-BI	
input	90-264V AC / 28V DC
power consumption	220W
CCT	5600K (D), 3000K-5600K (BI)
beam angle	45°
operating temperature	-10° to 35° C (14° to 95° F)
weight	19 kg (41.8 lb), PO+2 kg (+4.4 lb)

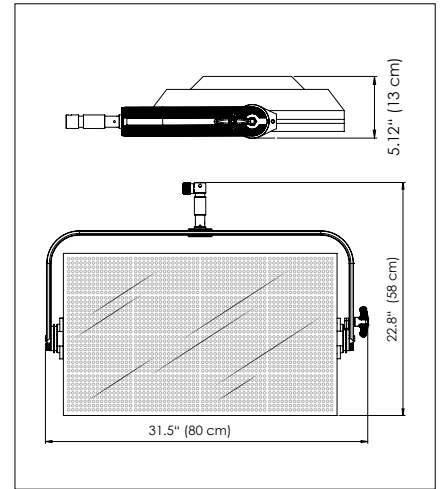

New: Ledrama soft box,
Front diffuser size: 108 x 60 cm
Includes optical wide-angle spreader for super smooth wide-angle light distribution, covering the entire front diffusor smooth and even

- Other accessories available:
- Honeycomb for front of soft box (40 degree)
 - Honeycomb attachment, mounted directly to the front of the light head (instead of the softbox)

DLEDRAMA-D LED Panel. Daylight approx. 5600K						
CRI Ra (1-8): >93		CRI Re (1-15): >90			TLCI: 96	
Distance	Meter	1	2	3	5	6
	Feet	3.3'	6.6'	9.8'	16.4'	19.7'
Intensity	Lux	23,600	5,900	2,622	944	700
	Foot-Candle	2,193	548	244	88	65

DLEDRAMA-BI LED Panel. Bicolor measured at 5600K – daylight and 3200K – tungsten						
CRI Ra (1-8): >93		CRI Re (1-15): >90			TLCI: 93	
Distance	Meter	1	2	3	5	6
	Feet	3.3'	6.6'	9.8'	16.4'	19.7'
Intensity D	Lux	23,600	5,900	2,622	944	700
	Foot-Candle	2,193	548	244	88	65
Intensity T	Lux	17,000	4,250	1,889	680	472
	Foot-Candle	1,580	395	175	63	44



LED FACTS AND TOOLS

FACTS:

Expectations often revolve around magic properties of the LED system.

No heat!

True, there is very little heat emitted forward from LED fixtures

BUT

Heat ON the LED light source is enormous. 80% of the energy is transformed into heat. Needs perfect cooling, because at 85°C, color, light output and lifetime are in danger. At 100°C the LED dies. Passive cooling (no fan) involves large cooling surfaces and contributes to weight. Active cooling (with fan) is needed especially for many of the higher wattage LED light sources.

Lifetime

A lot of information on the Internet suggests a lifetime of 50,000 hours or more. In reality, the lifetime maybe much lower in professional fixtures

Lumen Maintenance

The continuity of light output depends on the working temperature. In continuous use, the lumen output may be 20% lower after 10,000 hours (LM80).

Color quality

LED color quality cannot be measured with traditional color meters. It needs spectrum analysis.

Traditional CRI only shows 8 colors. Expanded CRI with 15 colors is more meaningful, but related to the response of the human eye. TLCI (Television Lighting Consistency Index) is an important step for the evaluation of LED light as seen by digital cameras, but refers mostly to studio cameras with 3CCD sensors. CMOS cameras may show many traditional light sources identically, but diverging results with LEDs. At dedolight we have been testing for many years our LED lights and others in most critical tests. Color rendition on human skin. One side of a face is lit with a reference light,

as used in professional work, such as halogen or Kino Flo daylight tubes, compared to the other side of the face which is lit with LED light. We have achieved satisfactory results in these most demanding, critical tests, showing good congruence of skin tones. We see this as a major breakthrough for our lights.

At dedolight we strive to find our color coordinates exactly on the Planck curve, and we work on very strict tolerances from this Planck curve (Δ UV maximum +/-0.0054). Any such minimal deviations will be measured with each light fixture individually and shown on the label of each light head.

Color Maintenance

Over many hours of use, dedolight LEDs may show lower color temperature in tungsten by approx. 100 Kelvin, whilst in daylight color the temperature may rise to approx. 200 Kelvin. Both values still stay 'on the Planck Curve'. No change in deviation from the Planck Curve (Δ UV), no shift towards green or magenta from the original color coordinates.

This is a major advantage, since shifts along the Planck Curve are less detrimental to skin tone rendition than green and magenta. We avoid green and magenta adjustment, as this is undesirable for skin tone rendition. Only when shooting in fluorescent light situations with strong green content, we suggest identical filters (1/2 plus green filters on all lights). Correction by white balance or in postproduction.

Advantages of our LED systems

- Best color quality
- Best color matching with traditional light sources
- Low power demand – mobile teams can work with camera batteries. High mobility, no cables.
- Bicolor version adjustable from 2,700K to over 6,000K
- Ability to match most ambient light situations by the turn of a knob.
- Successful transfer of our awarded and patented optical achievements.
- For each LED newly calculated optics



TOOLS:

For the biggest studio

Our multi-LED Ledrama panel lights offer highest efficiency. At 20 ft distance (6 meters) over 700 lux with only 220 W power consumption. New optics with over 2000 light sources provide gentle light character. Our Ledrama lights may be accompanied by our focusing DLED12 and DLED9 fixtures.

Mid-size studios

The Ledrama S 40x40 and our Felloni multi-LED panel lights work beautifully with our focusing DLED4 lights.

Mobile team

Our Portable Studio concept has been successful worldwide. Now available in LED systems.

BRAND NEW

Our focusing series of Turbo lights (see sep. brochure). Same size, same small kits and packages, seriously enhanced light output.

Onboard Lighting

Our Ledzilla light shows highest versatility also in bicolor version and with flip-up wide-angle optics for work at close proximity. Our 20 W focusing DLED2 lights are often used on-camera with and without soft box.

Light Shaping and Imaging Accessories

An incredible variety and choice of imaging and light-shaping accessories are available for all of our focusing LED lights.

New Versions

In 2018 we introduced multi-LED panel lights with drastically enhanced output. The Tecpro Felloni Turbo, which offers 5 times the light output over traditional Fellonis.

Miniature version -

In addition to the large, super power Ledrama lights we now have the miniature Pocket Ledrama, which is absolutely suitable for the smallest teams. Very high light output, similar to previous Fellonis, but can be fed by a single NPF battery and is also capable of wireless operation.

We should also mention the new LED soft lights Ledraptor 3, Ledraptor 5 and Ledraptor 7, which you will find in a separate brochure.

CLASSIC DEDOLIGHT – FOCUSING AND SOFT LIGHTS

Low voltage systems

The special light sources dedolight's use produce 40 lumen per watt whilst studio halogen lamps produce only 20 lumen per watt.

A traditional halogen Fresnel provides only 6% efficiency in its spot position. dedolight's have 3 times as much by virtue of our optics. Our low voltage light sources cost only 25% in comparison to high voltage halogen lamps of the same output. Additionally, low voltage lamps are not easily destroyed by shock or vibration, which makes them "travel-proof" and thus increases their life.

These 150 watt lights produce an output comparable to a 500 watt traditional Fresnel, but with a much higher focusing range. They also offer perfect light distribution, clean beam and unprecedented control accessories. dedolight's have become the lights of choice for the highest precision in lighting control on blockbuster films and smaller teams working under street fighter conditions.

Focusing dedolights with metal halide light sources

3 different series: Series 200 – Series 400 – Series 1200

- Another step in our award-winning optics
- Zoom focus
- Double aspherical optics
- Unprecedented control, quality and character
- Unique imaging

Panaura® Soft Lights

- True "wrap-around" light character
- No hot spot
- Light efficiency more than double in comparison to soft boxes in front of regular studio lights
- Less space, less weight, truly deserving the attribute "portable window"

The Portable Studio Concept

Unbeatable – over 10,000 users

- Lighter
- Most compact
- More versatile
- Indestructible
- The most economical lighting system available



Soft case with wheels for Portable Studio



DSC2W

robust soft case, identical to DSC2, but with wheels

The DSC2W soft case with wheels can be replaced on the following kits:

- SLED3 - 3-Light LED Kits
- SLED4 - 4-Light LED Kits
- S200-3 - Sundance Kit
- SPS4 - 4-Light Tungsten Kit
- SPS5 - 5-Light Tungsten Kit

Now also in hard case versions, with wheels and pull-out handle.

Imaging accessories

Optical design matching the optics of our focusing lights
Unprecedented light and shadow control.

dedolight super high transmission lenses:

- Highest resolution
- Perfect contrast
- No color fringing
- No halation
- No curvature of field
- None of the "seven sins" of imaging



THE NEW 1200 W DAYLIGHT-SYSTEM

Many years of experience culminate in this new concept. Double aspheric optics and zoom focus. These concepts are patented and have been twice recognized by the Oscar Committee of The Academy of Motion Picture Arts and Sciences.

DLH1200D, DLH1000T

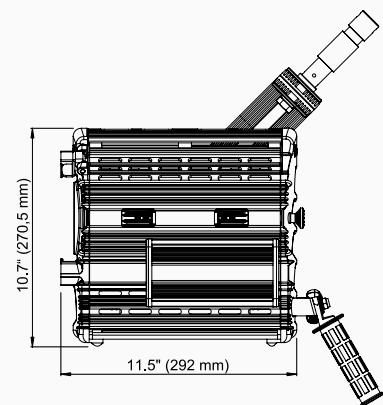
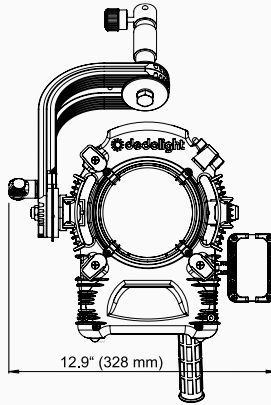

FOCUSING LIGHT HEAD: DLH1200D

Focus Range	1:18 with aspheric wide-angle attachment: 1:50
Lamp	DL1200DHR, 1200W, single ended hot restrike, G22.
Mounting	16 mm (5/8") receptacle and 28 mm (1 1/8") stud
Safety	Safety switch prevents operation when access door is open
ON/OFF:	On / Off buttons located on both, head and ballast, for ease of operation
UV	Extremely low UV emission
Weight	10.5 kg / 23 lb
Size	W: 12.9" (328 mm) L (flood): 11.5" (292 mm) L (spot): 11.5" (292 mm) H: 10.7" (270.5 mm)

- Higher light yield
- Higher focusability
- Perfect light and color distribution
- Highly efficient convection cooling
- Rainproof
- Super service friendly
- Flips open like a book – easy access
- Extremely low UV values, approx. 1/20 of the value shown by other lights

Hard Case DCHD1200

Size: 71 x 37 x 43 cm (2.3' x 1.2' x 1.4')
Weight: 14.5 kg / 32 lbs



DLH1200D Focusing Light Head. Daylight 5600K

Distance	Meter	1	2	3	5	10	15
	Feet	3'	6'	9'	15'	30'	45'
Flood	Lux	62,100	15,525	6,900	2,484	621	276
	Foot Candle	5,771	1,443	641	231	58	26
Medium	Lux	366,183	91,546	40,687	14,647	3,662	1,627
	Foot Candle	34,032	8,508	3,781	1,361	340	151
Spot	Lux	783,000	195,750	87,000	31,320	7,830	3,480
	Foot Candle	72,770	18,192	8,086	2,911	728	323

DLH1000T Focusing Light Head. Tungsten 3200K

Distance	Meter	1	2	3	5	10	15
	Feet	3'	6'	9'	15'	30'	45'
Flood	Lux	14,670	3,668	1,630	587	147	65
	Foot Candle	1,363	341	152	55	14	6
Medium	Lux	36,675	9,170	4,075	1,468	368	163
	Foot Candle	3,408	852	379	136	34	15
Spot	Lux	156,150	39,038	17,350	6,246	1,562	694
	Foot Candle	14,512	3,628	1,612	580	145	65

DEB1200D THE ELECTRONIC BALLAST



DEB1200D Electronic Ballast

- Leading edge technology
- Low heat dissipation
- Silent ventilator remains off during normal operation and operates under high heat conditions only
- Active power factor correction (PFC)
- Funktional range from 90-264V AC
- Overload protection
- Surge protection
- Short circuit protection
- Auto start function
- DMX control is standard
- Rainproof construction
- The ballast can be opened within 30 seconds – like a book
- Full access to all elements and electronics

DPOW1200D Cable

Connection cable between light head and ballast

Technical Data: DEB1200D Electronic Ballast

The frequency to operate the lamp is switchable from normal flicker-free function to 1000Hz for high-speed recordings

Weight:
11.4 kg

Output Power:
1200 W

Input Voltage:
90-264V AC *

Indicators:
3 Status-LEDs (Ready, Lamp, Heat)

Dimming Range:
50-100%

DMX-Control
DMX control and auto start mode can be chosen.

Stand mounting optional with double-holding clamp: DEB1200H

**) functional range including tolerances*

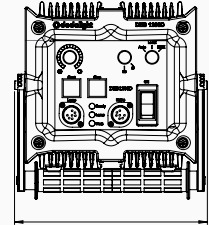

9" (225 mm)

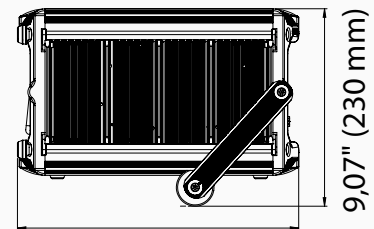

12,95" (328 mm)

9,07" (230 mm)

THE TUNGSTEN-EDITION OF THE NEW SERIES 1200



DLH1000T

A mains operated light with unrivaled focusing range and superior light quality. Can be used with 1 kW halogen lamp, G22 socket. Further G22 lamps upon request.

DLH1000TPO

Pole operated version for studio applications



DLH1000T-DMX

DLH1000TPO-DMX

with DMX controlled integrated dimming

DP1200KU

Complete imager with universal module for Series 1200 light heads. 150 mm projection lens, gobo holder and gobo set included.

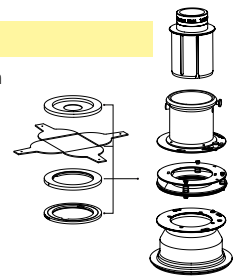

Optional inserts:
Glass gobo holder, loose framing shutter blades for each, to be individually inserted - Iris: we will soon have a complete iris module. No more iris to be inserted.

DP1200KFS

Complete imager with framing shutter blade module for Series 1200 light heads. 150 mm projection lens included.



DP1200CON - WA

Condensor for special wide-angle lenses 70 mm and 100 mm with special versions of framing shutter and universal modules.



THE PORTABLE WINDOW

A DEDICATED SOFT LIGHT SYSTEM

Why do we call it dedicated?

Similar to the other known seven dedolight soft lights, these have been conceived exclusively as optimal soft lights

- Light output is double in comparison to a soft box in front of a studio Fresnel light, because the actual light sources are placed in the focal point of the reflector
- Gentle wrap around character

On an optimum soft light source, the light emission on the large diffuser should be perfectly even to the edge. It should even be somewhat more intense towards the edge.

Both variations are offered by this soft light by changing the standard inner diffuser with a rim-aura diffuser (both types included).

- The standard inner diffuser provides perfectly smooth and equal light distribution

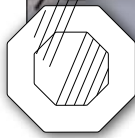

The inner Rim-Aura diffuser provides a brighter rim area (Aura) on the front diffuser and is closer to the idea of a "wrap around light"



Alternatively, use the large inner diffuser for all over even light



Panaura® 7 with 40° grid

Tungsten / Daylight

dedolight is probably the only one who offers the interchangeability of daylight discharge lamps with tungsten discharge lamps. Both have equally high light output, identical high color quality and both work with the same ballast.



DL400DHR-NB

Metal Halide Lamp 400/575 W Daylight

DL575THR-NB

Metal Halide Lamp 400/575 W Tungsten

intensity control in six steps with no change of color.

This two lamp system offers a wide range of intensity control. Each lamp is individually controlled and can be switched from 575 W to 400 W or continuously dimmed to 300 W and then switched off. This results in an unprecedented range of intensity control without any change to color quality. Unprecedented for any such system working with discharge light sources (metal halide – HMI)

Higher Output – More Light – Less Consumption – Less Heat



DLHPA7x2DT

Soft light head for 2 lamps, daylight or tungsten, interchangeable, same high light output. Both lamps work with the same ballasts.

How do you want to call it?
Energy Efficient? Green-Tec?
dedolight Panaura®?
The Portable Window?
... or just the soft light with the most loving character?

Even though we do not favor the hot spot philosophy, we still have 140 percent light level in the center compared to a 5000 W tungsten Fresnel with a soft box and we use only 1150 W

250 percent light level towards the rim compared to a 5000 W tungsten Fresnel with a soft box – and we still only use 1150 W.

Panaura® 7 compares favorably with a soft box on a 2.5 kW daylight studio light – more light and uses only 1150 W.

DLPA7*

- dedolight Panaura® 7 textile reflector with
- additional rear cowl and
 - 2 different inner diffusers (DLPA7D2 standard diffuser and DLPA7D2S rim aura diffuser)
 - as well as the DLPA7D1 large front diffuser.

DLPA7G



40° grid for all Panaura® 7 models

DEB400DT

Electronic flicker free ballast for 400/575 W daylight and tungsten discharge lamps.



DPOW400DT

Connection cable between light head and ballast

DEB400Hx2

Extending ballast holder for better balance



DLHPA7-EXT

Yoke extension
For use with Panaura® 7 in tilted position for extra distance between light stand and Panaura® 7.



DSCPA7W

Panaura® 7 soft case with wheels

* When using the Panaura® 7 with DLHPA7x2T and Panaura® 5 with DLH1000SPPLUS head with halogen lamps in a straight downward position (for extended period of time), please order "heat shield inserts".



For Panaura® 5 Set:

DLPA5-HTS4
with 4 heat shields



For Panaura® 7 Set:

DLPA7-HTS3
with 3 heat shields

DLPA5-HTS8
with 8 heat shields

DLPA7-HTS8
with 8 heat shields

SPA7x2DT

Interchangeable Tungsten/Daylight Panaura® 7 Kit

- robust transport soft case with wheels
- soft light head
- 2 x 400/575 W daylight lamps
- Panaura 7 soft box with rods and baffle
- incl. 2 types of inner diffusers
- incl. 1 front diffuser
- 2 ballasts and cables
- variable ballast holder



optional:

- yoke extension (DLHPA7-EXT)
- stand with 28 mm receptacle (DST1200)
- grid (40°) for Panaura® 7 (DLPA7G)
- 575W tungsten lamps (DL575THR-NB)

Pure Tungsten

Variations of Panaura® 7

When you don't need daylight and the flexibility to change between daylight and tungsten (interchangeable lamps), you may want a pure halogen tungsten soft light.

Tungsten Panaura® light head DLHPA7x2T works with two 1000 W halogen lamps.

All halogen lamps are individually switchable or can be dimmed individually with our new dimmers DLDIM2000.



DLHPA7x2T Tungsten 2 x 1000 W

Soft light head for 2 lamps 1000 W halogen with protective glass tubes

Pure Daylight

Variations of Panaura® 7



DLH1x1200SD Daylight 1 x 1200 W

Our newest Panaura 7 soft light works with a single 1200 W lamp (G22 socket). Integrated speed ring for Panaura® 7 soft box. It may be powered by the new DEB1200D ballast which offers manual dimming and DMX control as standard.

Size, Depth, Weight

The Panaura® family comes in 3 sizes, all offer superb soft light character without any hot spot, and the choice of different inner diffusers allows smooth and even light distribution or the typical Panaura® look with the brighter rim towards the outside - the true loving, caressing wrap-around light character.

When working in confined areas the depth of the light head can make the decisive difference whether this wonderful, creative tool can be used at all. The very shallow depth of this portable window system offers distinct advantages in space consumption.

Also much less weight, higher light efficiency, lower heat, lower power consumption (never blow a household fuse).

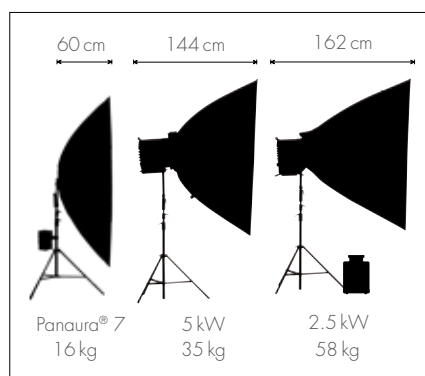

dedoflex MULTIDISC 5 IN 1

The MultiDisc 5 in 1 offers five reflector surfaces. Translucent, white, silver, gold, and soft gold in one easy to carry package. Switch surfaces in seconds.

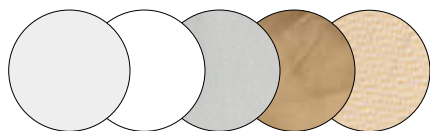

- Translucent: Use to diffuse light. Produces a broad light source and soft effect.
- White: Use to reflect light with natural looking results.
- Silver: Use to increase specular highlights adding more contrast to your image.
- Gold: Use for a strong warming effect in your lighting
- Soft Gold: Use for natural looking, warmer reflected light. Soft Gold combines silver and gold in a zig-zag pattern for a warm, summery feel that works great with skin tones.

The heavy duty steel frame is guaranteed not to break for the life of the product. Reflector surfaces are smooth and flat for consistent, even reflections. The MultiDisc comes in its own protective, durable fabric case for storage and transport.



DF5IN1-56

Small 56 cm (22")

DF5IN1-81

Medium 81 cm (32")

DF5IN1-106

Large 106 cm (42")



DLTCH Compact Disc Holder

The new compact holder for dedoflex reflectors and diffusers as well as for dedoflex 5 in 1 MultiDiscs. The holder consists of two parts and can be expanded from 71 cm/28" to a maximum of 127 cm/50". A 16 mm stud is provided for mounting accessories or light heads.

WIDE EYE - NEW WIDE ANGLE OPTIONS

Enables focus range like no other light.

When light is pointed downward – even from an angle – rotating barn door leaves provide parallel shadows, for the first time in lighting history



Your Rembrandt,
lit with a traditional 8-leaf barn door
(Many barn doors only have 4 leaves)



Our system turns the 'unavoidable'
trapezoidal shadow edges into parallel shadows.



All focusing dedolights offer a focus range like no other lights worldwide.

New – a 30mm dedolight 'Eagle Eye' projection lens. A further masterpiece of our optical design department.

Adding the dedolight aspherical wide-angle attachment, the enormous focus range is further enhanced and still allows focusing.

These attachments are equipped with individually rotating barn door leaves.

dedolight focusing lights offer unprecedented focus range (change of beam angle).

Traditional small studio lights offer a focus range of 1:3. Some large studio fixtures reach 1:6 dedolights, even in the smallest versions, excel with a focusing range of 1:25. These figures refer to change of intensity, when focusing from flood to spot. At the same time, the variation of exit angle is changed from 60° to 4°. Such values are not obtainable for any other light. Adding the Wide-Eye attachment, the focusing range of the dedolight is further enhanced to a range of 1:55, and the exit angle from 4° to nearly 90°.

For video cameras, such aspherical, optical attachments are known, but nobody has ever built anything like it for the focusing lights.

Power wide-eye attachments available in four different sizes:

- For smallest focusing lights DLED2/DLED3
- For classic lights like DLH4, 200 W Sundance, DLED4 and DLED7
- For series 400, DLED9, DLED10
- Series 1200 DLED12 and DLED30

Why do we need rotating barn door leaves?

All traditional barn door leaves can only be adjusted parallel to each other.

Isn't that amazing...practically most lighting situations work from an angle (usually from above) in which case the shadow edges of traditional barn door leaves will no longer show as parallel, but as a trapezoidal shape.

That is not the way our houses, rooms, doors and pictures are built. When rotating the barn door leaves of the dedolight (special barn doors like DBD2 and the barn door leaves on the wide-angle attachments) it enables you for the first time to light vertical and rectangular edges of objects with precision.

An exclusive step in the history of creative light-shaping for precision lighting.

- widen angle of exit up to 85° or 90°
- perfect light distribution
- minimum light loss
- continuously focusable
- always full control - these Wide Eye attachments work with 8 barn door leaves
- even better - the barn door leaves can rotate (another dedolight patent)



DLWAR

Wide-angle attachment with rotating barn door leaves for classic dedolight

DLWA400R

Wide-angle attachment with rotating barn door leaves for Series 400 lights

DLWA1200R

Wide-angle attachment with rotating barn door leaves for Series 1200 lights



HIGH TECH NOISELESS MosFET DIMMERS - ALSO WITH DMX

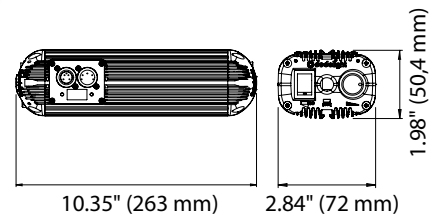

DLDIM2000

240 V max. 2 kW
120V max. 1 kW

DLDIM2000-DMX

DLDIM2000 with integrated DMX control
This dimmer can control many dedolight tungsten focusing and soft lights along with lights of other manufacturers up to 2 kW at 230-240 V or up to 1 kW at 100-120V. Since these DMX-controlled dimmers are noiseless, they can be mounted next to the light.

Mounting devices for attaching to pipes via clamps are available. As a result, many studios will be able to eliminate external dimmers which often generate noise and require a room of their own. Our high tech dimmers bridge the missing gap of DMX for all halogen studio lights.

dedolights with integrated DMX Dimmers

Are used in many TV studios. Most Kinoflo lights can be DMX controlled. Other focusing lights are usually not DMX controllable. This is one of the reasons why our dedolight 150 W DMX controllable light heads (DLHM4-300DMX) which offer a light output similar to a traditional 500 W Fresnel, are used in many TV studios. Also our daylight light heads are DMX controllable.



150W light head with light output similar to traditional 500W Fresnels (DLHM4-300DMX)

The dedolight DLH400DT daylight fixture, with its DEB400DT ballast is also available with DMX control.



650W pole operated light head (DLH650PO-DMX)

Our new 1200 W daylight source (DLH1200D) and DEB1200D ballast are equipped with integrated DMX control as a standard.



1000W pole operated light head (DLH1000TPO-DMX)

12/24 V Inline Dimmer

Working with batteries, overvoltage can occur quite frequently. As an example - professional video camera batteries which are nominally called 12 V batteries are no longer true 12 V versions but mostly 14.4 V - and when they are freshly charged they provide up to 17 V. The DLDIM-BAT dimmer solves this problem.

DLDIM-BAT

The Classic dedolights work with 12V and /or 24V special low voltage lamps. These lamps offer the following advantages:

- extreme high light output for a halogen system with 40 lumen per Watt (standard high voltage halogen lamps only provide approximately 20 lumen per Watt)
- resistant to shock and vibration (which is definitely not a virtue of high voltage halogen lamps)
- drastically lower purchase cost (75% less)
- longer life expectancy
- BUT: ALL HALOGEN LAMPS WHICH OFFER VERY HIGH LIGHT OUTPUTS ARE SENSITIVE TO OVERVOLTAGE.
- Switch the voltage selector to the 12V - DC position - Now you can feed up to 18V, but the maximum output voltage is limited to 11.8V. This is suitable for 12V - 20, 50, 75 and 100W lamps.
- Switch the voltage selector to the 24V - DC position - Now you can feed up to 36V, but the maximum output voltage is limited to 23.5V. This is suitable for 24V - 50, 100 and 150W lamps.
- The lamps will be gently started (SOFT START) when switched on.
- Recognition of defective or missing lamp (blink code with LED indicator)
- Short circuit and overload protection
- Smooth dimming range 3-100%
- Robust and small housing
- Low voltage cutoff at 10.2V respectively 20.4V for protection of batteries
- When input voltage is lower than 12V the maximum output (100%) cannot be reached. Similarly, in 24V mode the maximum is not possible when the input is below 24V



BACKGROUND FX GLASS

To be used with our DP1S Imager (Ø 55 mm), DP1.1 (Ø 66 mm) and DP400 (Ø 100 mm) imagers. Background FX glass quickly change any flat, drab background into a stunning piece of set design.

With eleven different patterns and eight colors, dozens of effects can be created.

Focusing and defocusing the pattern changes the mood.

Sandwich them together with standard metal gobos and you have an even wider choice.

All effects and colors are also available for the DP1S (Series DLED2, DLED3) and the DP400 (Series 400, DLED9, DLED10) imager. For the Series DLED2 is no separate effect glass holder required.



For our background effect filters / glasses we do NOT guarantee consistency of color and density.

Each pattern is available in 8 highly saturated dichroic colors:

Light Blue (LB), Purple (P), Orange (O), Red (R), Magenta (M), Yellow (Y), Turquoise (T), Light Green (LG)

Sample order code: DFXST3-LB = „Waffle“ Light Blue – for Series DLED2 and DLED3
 DFXT3-LB = „Waffle“ Light Blue – for Classic Series, DLED4 and DLED7
 DFX400T3-LB = „Waffle“ Light Blue – for Series 400, DLED9 and DLED10

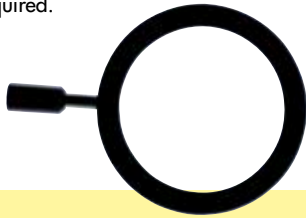

DFXH

Effect Glass Holder for Ø 66 mm (M size)

DFX400H

Effect Glass Holder for Ø 100 mm (A size)

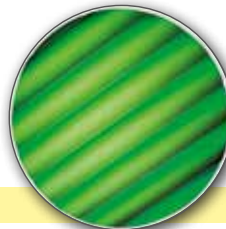

DFXT4

Effect Glass "Waves"



DFXT8

Effect Glass "Crystal"



DFXT1

Effect Glass "Harmony"



DFXT5

Effect Glass "Lamello"



DFXT9

Effect Glass "Flow"

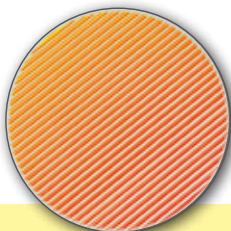

DFXT2

Effect Glass "Groove"



DFXT6

Effect Glass "Mystic Squares"

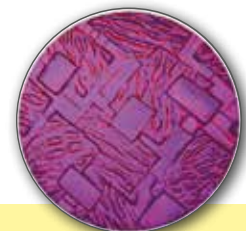

DFXT10

Effect Glass "Farrago"

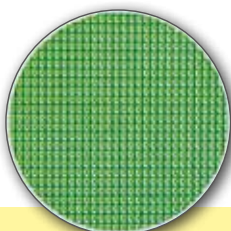

DFXT3

Effect Glass "Waffle"



DFXT7

Effect Glass "Cakester"



DFXT11

Effect Glass "Cells"

DIRECTIONAL BEAM SPREADER DWAFX



HIGH TRANSMISSION – PRACTICALLY NO DIFFUSION

A special structure in a metal frame / holding ring – These unique light-shaping attachments spread the defined beam of the focusing dedolight in one direction. The orientation of the beam spread can be rotated.

The effect on a dedolight:

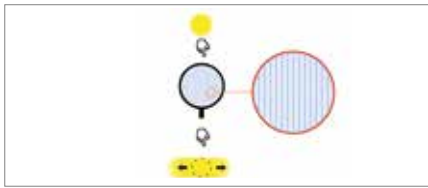

On multiple dedolights:

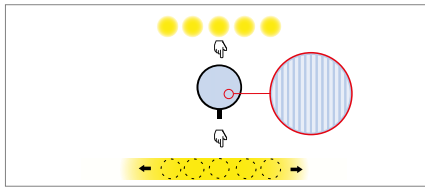

Can also be used for a combination of several dedolights in spot or medium focus position (all with equal focus and intensity settings – DMX), placed in parallel direction to achieve a uniform band of light.

Similar effects have always been possible on focusing studio lights or lights with a defined beam angle by adding a gel filter called "brushed silk". This is still valid, but will always produce a noticeable amount of diffusion at the same time as spreading the light beam in one direction.

With the unequalled dedolight and its clean beam concept, these directional beam spreaders DWAFX allow the spreading of the light without causing diffusion.

1

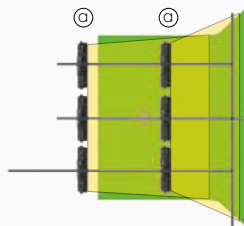
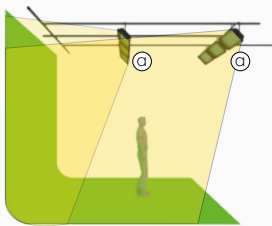

In virtual studios, great care is taken to light the green background and floor evenly and free of shadows.

1a This, for example is lit in the most efficient way by two rows of our Ledrama lights, equipped with our wide-angle diffuser. In most cases, the lighting on the lonely person in the green desert looks relatively sad and unstructured when shooting a medium shot or close-up in such situations. It rarely ever happens that the light on the person has anything to do with the lighting found in the virtual background.

Use of DWAFX beam spreader for backlight and contour light in a virtual studio

2

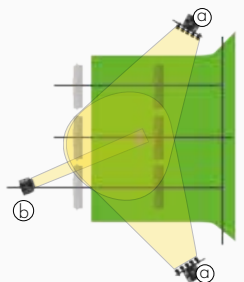
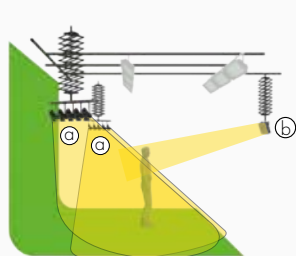

Row of focusing dedolights with a beam spreader DWAFX on each light (2a) will create a homogeneous „river of light“. One row on the left – one row on the right towards the back of the studio

DMX control allows you to tune intensity from one side or the other.

Also you can vary the color temperature and match the mood and character of the virtual image.

The homogeneous "river of light" allows the talent to move in the set without change of intensity.

Add a front light to bring eye reflexes to life (2b), and you have gained a significant step. Ask for our movies showing such practices.

- For tungsten use dedolights DLHM4-300DMX or DLH650DMX
- For daylight use dedolights DLED4-D or DLED9-D
- For controlled changes of color temperature for back light and contour light use bicolor versions of DLED4SE-BI-DMX or DLED9SE-BI-DMX

These orientable DWAFX attachments / filters are available in 3 sizes for focusing dedolights.

For classic dedolights (Code DWAFX), e.g. DLH4, DLHM4-300, DLH200DT, as well as the new focusing LED lights DLED4 and DLED7.

For the Series 400 (Code DWAFX400), suitable for dedolight heads DLH400DT, DLH650, DLH652T, as well as the new DLED9 and DLED10.

For the Series 1200 (Code DWAFX1200), fitting DLH1200D, DLH1000T, as well as DLED12 and DLED30.

SLIDE PROJECTIONS FOR STUNNING EFFECTS AND TEACHING LIGHTING SETUPS FOR VIRTUAL STUDIOS

For classic dedolight

DP3.1 imager/projection attachment
Use with DLH4, DLHM4-300, DLH200DT and DLED4, DLED7 Series lights for gobo and slide projection.

Choice of projection lenses:
30, 50, 60, 85, 150 and 185 mm, as well as two zoom lenses 70-120 mm and 85-150 mm.



DP3.1

DP3.1

DP400SHA

With the slide holding attachments which are available for all series of dedolight, slides can be projected.

Usually this wants to be done from an angle, so that the person in front of such a projection will not be touched by the light from the slide projection. This can be done from an angle of 45° or 30°.

Maintaining equal focus from left to right can be achieved by the adjustment of the image plane in our projection devices (left-right as well as up-down).

For light heads of Series 400

For DLH400DT, DLH650 and also the new DLED9 and DLED10 lights you can use DP400 imager / projection attachment with slide projection



DP400SHA

For our larger lights

The DP400 imager/projection attachment in combination with a DP1200CON or DP1200CON-WA condenser module may be used with the DLH1200 metal halide light head as well as the DLED12 and DLED30 focusing LED light head.

DP1200CON - Standard

For lenses 150 mm, 185 mm and 230 mm focal length (also possible with 100 mm)

DP1200CON-WA – Use for wide-angle

projection lenses 70 mm and 100 mm (150 mm is also possible)



in focus



slide projection out of focus

The background will always appear in focus when using cameras with a small sensor and short focal length lens. Sometimes the effect of a greater separation or space can be achieved by throwing the projected background out of focus – easily done by defocusing the projection lens on our imager.

If further refinement of such effects is wanted, e.g. on a landscape setting, this is possible (by virtue of our moving image plane in the imager) so that the foreground (e.g. the lower part of the image) can be kept in focus, whilst half or two-thirds of the upper image on the projected background can drift out of focus, again creating the illusion of greater depth.

This is also a subject which we will describe in one of our future videos, to show how easy such effects can be achieved.

For the projections of 45° or 30° angle we usually distort the slides in the computer before printing them, and then they will distort on the background onto which the slides are projected so that parallel horizontal description can be maintained. Such slide projections can be used as an easy background projection without the hazards of disturbing reflections from green or blue backgrounds. This may occur when there is not enough space between the talent and the green or blue background.



No distortion



Distorted slide for 30° or 45° projection

To teach lighting for virtual studios, a slide projection can be a wonderful tool. In the same view for the eye, as well as the camera, the projected background image appears at the same time as you can see the setting of the lighting on the talent. Trying to match the lighting in the background is often easily achieved, sometimes aided by the addition of color effect filters.

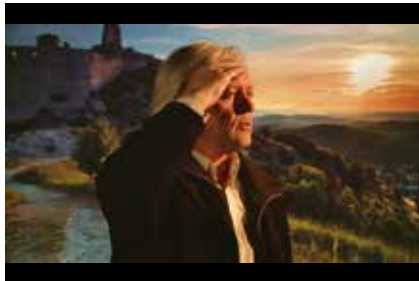

For the aspiring media student this can be a great learning experience, also for choosing suitable light sources to make the lighting on the talent melt in a natural way into the virtual background (Visibly projected background), and still separate the talent by lighting from the background.

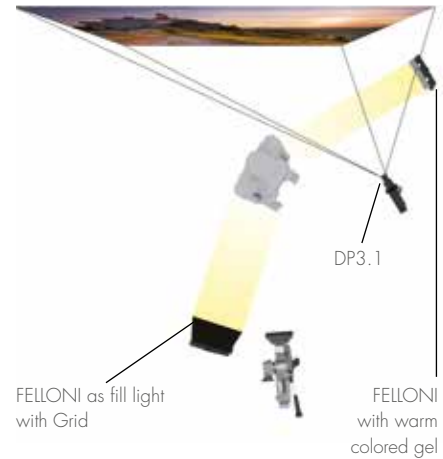

Which slide formats to use for classic dedolight

When you are projecting onto a background, you will not want to see this projection on a person in front of the projected background. Therefore you will place the projector 30 degree (or 45 degree) away from camera axis. With our slide projections, we can adjust the image plane (in 2 axis) and control focus even for projection from an angle.

But we will create key stoning – the projected image will appear distorted.

To compensate key stoning / distortion when projecting from an angle, we pre-distort the images in the adverse direction (in Photoshop). Then the projected image will be displayed without distortion.

Today many backgrounds are created with green screen technology – slide projections occasionally offer an interesting alternative. Even if in the end you will use green screen, the slide projection offers a perfect and direct exercise for matching the lighting on the talent with the character of light in the background.

Our slide projectors come in 2 versions.

DP3.1

A complete unit for the classic dedolights DLH4, DLHM4-300, DLH200DT (see page 46) for use with modified 35 mm slide frames (free window 35 mm wide, 32 mm high). Order code: **DPSFD**

For projection with 85 mm lens from 30 degree angle, distort top and bottom with 3.4 degree (image height will be 32 mm and 25.5 mm left/right)

DP400SHA

Module for our larger DP400 imager/projector (see page 46). Uses regular slide frames 2 1/4 x 2 1/4 (60 x 60 mm). Order code: **DP400SF**

For projection with 150 mm lens from 30 degree angle, distort top and bottom by 5.7 degree, resulting in image height 60 mm and 48 mm (left/right)

Service for slide production with your own images

Using your own images – depending on the application – you may want to make sure that you are in possession of the rights to these images. Transmit the images to us and we can take care of suitable pre-distortion, developing and framing.

Order code: **DPSCD** (for **DP3.1**)
Order code: **DP400SCD** (for **DP400SHA**)

It is best to use slide frames with no protective glasses.

It may be advisable to have several duplicates made, if you want to use the same slide image for a longer period.





Dedo Weigert Film GmbH

Karl-Weinmair-Straße 10
D-80807 Munich, Germany
Phone: +49-(0)89-356 16 01
Fax: +49-(0)89-356 60 86

info@dedoweigertfilm.de
www.dedoweigertfilm.de
www.youtube.com/user/dedoweigertfilm