

STAGE 2 116 CAMSHAFT AND THROTTLEBODY KIT MODEL YEAR 2020+



P/N 2884323

IMPORTANT

Due to the technical nature of this kit, Indian® insists that this installation be performed by a certified Indian Motorcycle® Technician.

NOTICE

Factory approved and certified accessories and calibrations are designed for maximum performance, while protecting the engine over a wide range of operating conditions. Use of aftermarket or unapproved accessories or calibrations will cause abnormal sensor or engine operation, error codes and risks damage to the engine. The Indian Motorcycle® Limited Warranty *excludes* damages or failures resulting from use of aftermarket or unapproved components, accessories, and calibrations.

APPLICATION

Model Year 2020 and newer Indian Motorcycles® with 116 Thunder Stroke®

Verify accessory fitment at www.indianmotorcycle.com.

BEFORE YOU BEGIN

Read these instructions and check to be sure all parts and tools are accounted for. Please retain these installation instructions for future reference and parts ordering information.

REQUIRED SOLD SEPARATELY

Only parts for installation of the Indian Motorcycle® Stage 2 116 Camshaft and Throttlebody Kit Model Year 2020+ are included. Prior installation of the following additional kits is also required (sold separately):

- *Stage 1 High Performance Air Cleaner Kit*, PN 2881779-XXX or *Thunder Stroke® High Flow Air Cleaner Kit*, PN 2880654-XXX
- *Stage 1 Muffler Kit*, PN 2879529-XXX, 2879724-XXX, 2879768-XXX, 2879769-XXX, or 2884187-XXX

NOTE

XXX = Indian® color code (For example: 266 = Black)

KIT CONTENTS

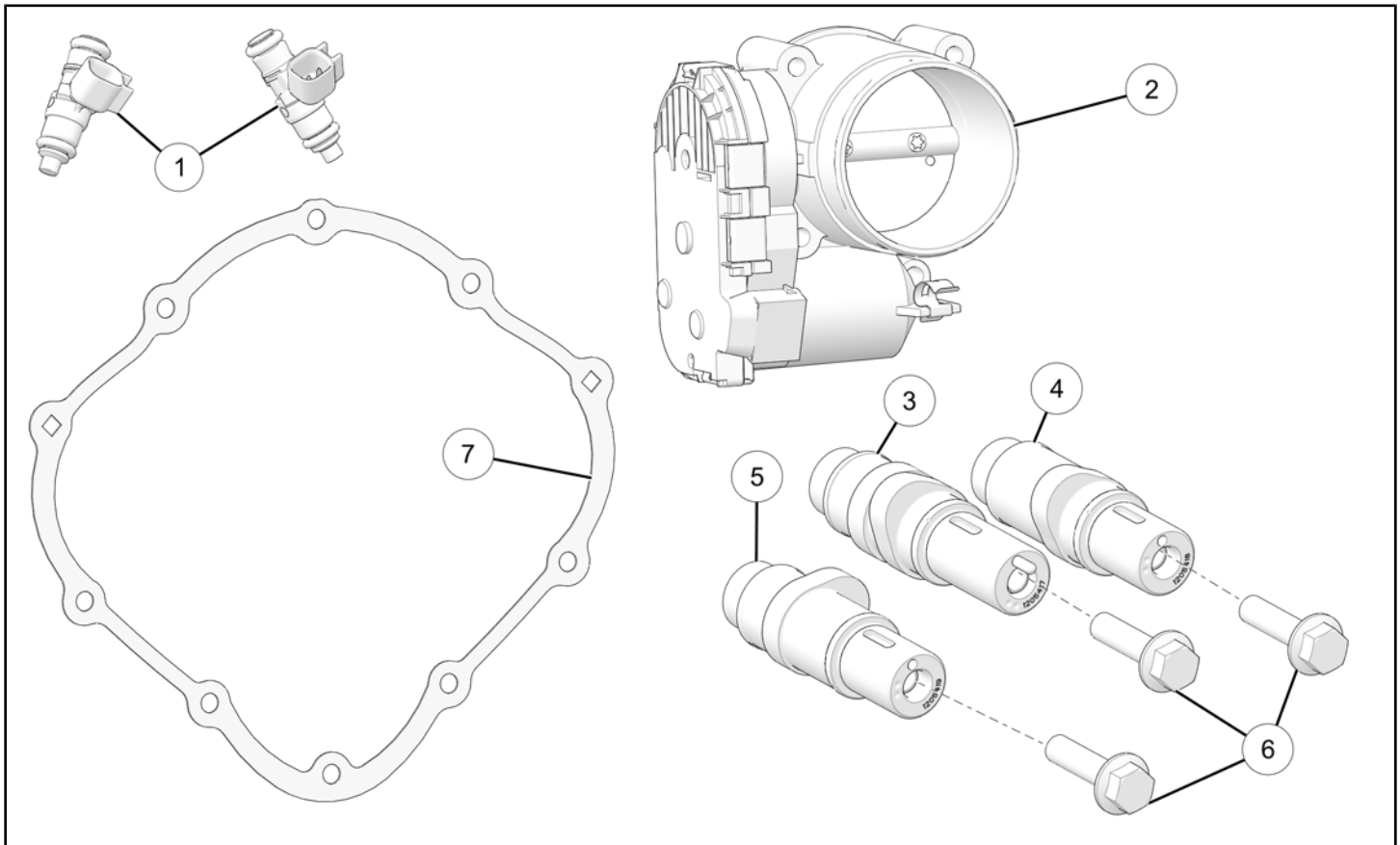

REF	QTY	PART DESCRIPTION	P/N AVAILABLE SEPARATELY
1	2	Fuel Injector	2522178
2	1	Assembly, Throttle Body	1204975
3	1	Assembly, Camshaft, Stage 3, Intake	1205417
4	1	Assembly, Camshaft, Stage 3, Exhaust-Front	1205418
5	1	Assembly, Camshaft, Stage 3, Exhaust-Rear	1205419
6	4	Screw, Hex Flange Head, M10 X 1.5 X 40	7519763
7	1	Gasket, Camshaft Outer Cover	5813898
8	1	Calibration Card, 50 State Indian® (Not Shown)	4014490

TOOLS REQUIRED

- Safety Glasses
- Digital Wrench
- Drain Pan
- Hammer, Soft Face
- Platform Jack, Motorcycle
- Pliers, Side Cutting
- Pry Tool
- Screwdriver, Phillips
- Screwdriver, Slotted
- Socket Set, Hex Bit, Metric
- Socket Set, Metric
- Socket Set, Torx® Bit
- Torque Wrench
- Wrench Set, Metric

- Vehicle Lift/Support Equipment

- **Special Service Tool:** Camshaft Holding Tool PF-52544 and PF-524544 **or** PF-51455-A (Combination Kit)

CONSUMABLES REQUIRED

- Gloves, Chemical Resistant
- Grease, Polaris All Season (or equivalent)

IMPORTANT

Your Indian Motorcycle® Stage 2 116 Camshaft and Throttlebody Kit Model Year 2020+ is exclusively designed for your vehicle. Please read the installation instructions thoroughly before beginning. Installation is easier if the vehicle is clean and free of debris. For your safety, and to ensure a satisfactory installation, perform all installation steps correctly in the sequence shown.

INSTALLATION INSTRUCTIONS

VEHICLE PREPARATION

GENERAL

IMPORTANT

- Protect all finished surfaces during these operations.
- Take careful notes of wire routing and cable tie locations during disassembly to ensure proper reinstallation.
- Special care should be taken on higher mileage bikes during disassembly. Especially when removing fasteners threaded into engine block and cylinder heads (For example: Exhaust manifold bolts, Primary cover bolts, etc.) Thread repair kit may be necessary if threads become damaged.

1. Turn key or ignition switch to **OFF** position and remove key. If equipped with keyless fob, remove fob from proximity of vehicle.
2. Ensure motorcycle is parked on a flat surface, kickstand is fully extended, and vehicle is stable prior to installation.
3. Support motorcycle securely in an upright position. Clamp front tire securely in a wheel vise.
4. Drain engine oil.
5. Remove and retain upper and lower side covers, saddlebags, and seat as per owner's manual. Disconnect battery as per owner's manual.

RIGHT FLOORBOARD REMOVAL

1. Remove cotter pin (A) and washer (B) from brake master cylinder pushrod.

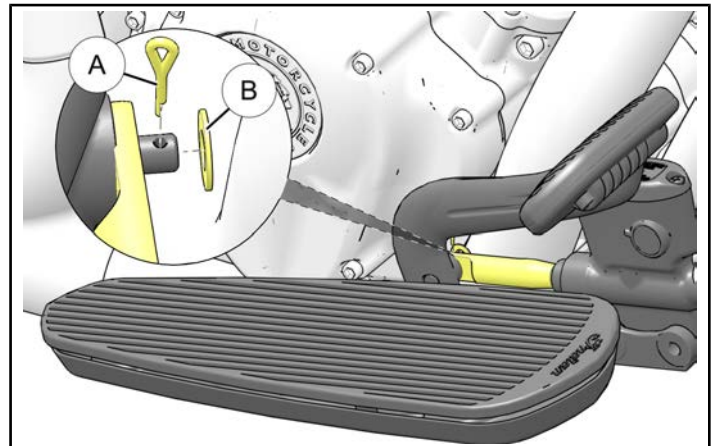

- Remove and retain two screws (C) from brake master cylinder (D), disengage pushrod from brake pedal assembly, and remove brake master cylinder (D) from RH floorboard assembly and move out of the way.

CAUTION

Do not bend or kink flexible brake line during floorboard removal. Master cylinder assembly should be kept in an upright position and properly supported at all times.

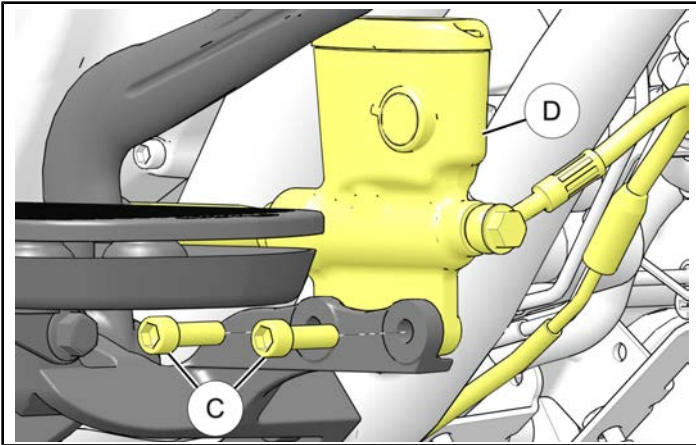

- Remove and retain two bolts (E) and remove RH floorboard assembly (F) from frame.

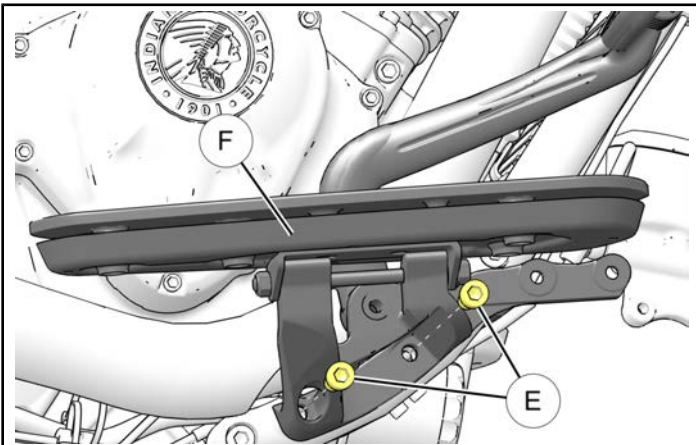

ACCESSORY INSTALLATION

REMOVE FUEL RAIL

- Remove fuel rail and fuel injectors as per service manual.
- Lubricate new injector (1) o-ring with clean, silicone-free motor oil. Install Stage 2 Kit Fuel Injectors (1) by carefully pressing into manifold.

- Install fuel rail as per service manual and torque screws to specification.

TORQUE

Fuel Rail Screws:
88 in-lbs (10 N·m)

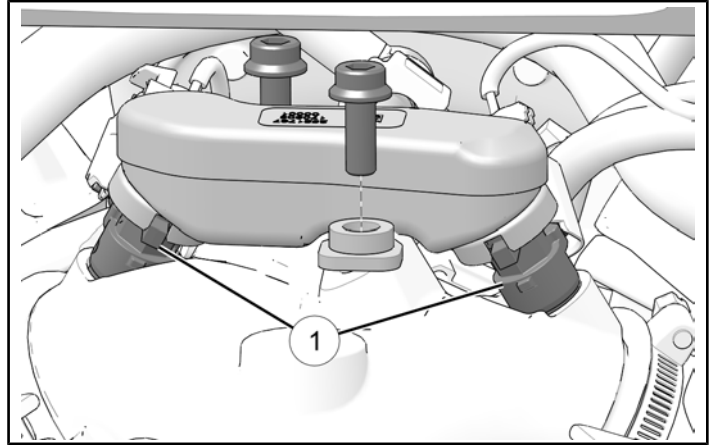

REMOVE AND INSTALL CAMSHAFTS

CAM CHAIN, GUIDE AND TENSIONER REMOVAL

- Remove and retain ten fasteners (A) and (B), make note of different sizes and locations. Remove cam chain cover (C) and gasket.

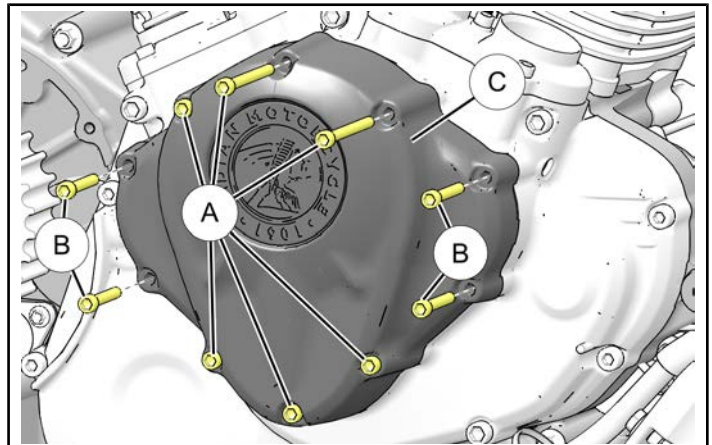

2. Ensure indents on gear faces align with each other as shown. If they do not, repeat crankshaft locking procedure and align them.

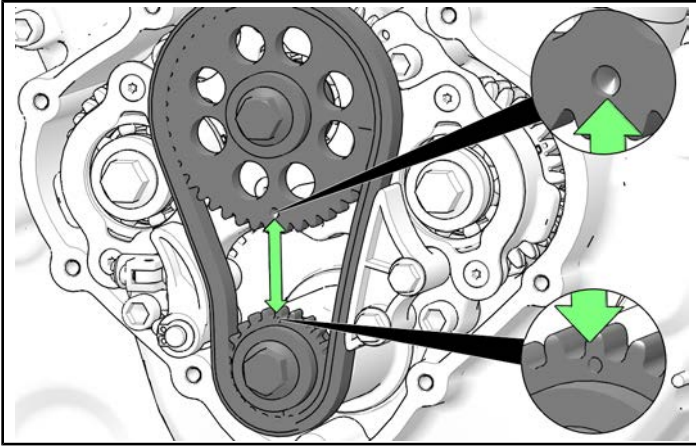

3. Loosen, but **DO NOT REMOVE** four screws ①.

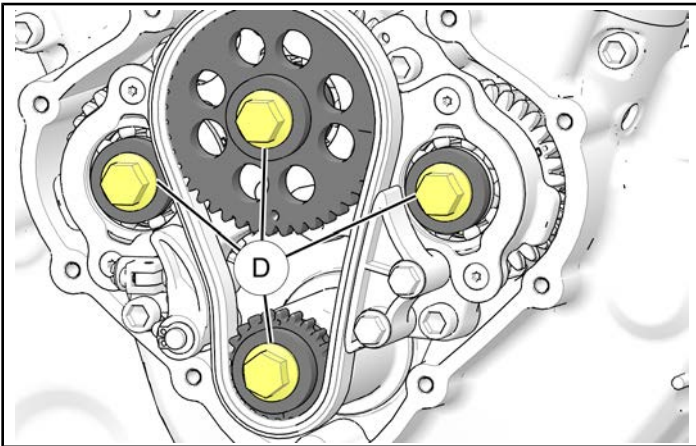

4. Remove and retain chain tensioner fastener ⑤ and chain tensioner ⑥.

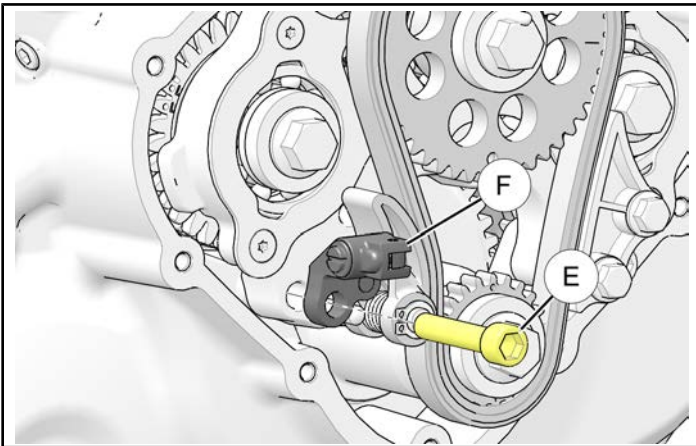

5. Remove and retain external snap ring ⑥ and chain tensioner arm and spring assembly ⑧.

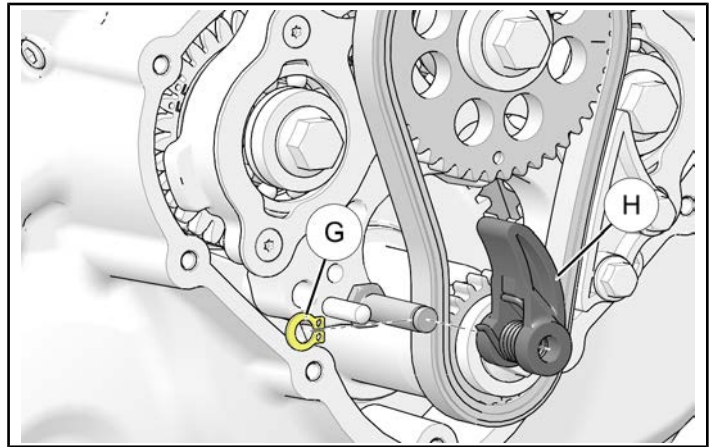

6. Remove and retain two fasteners ⑩ and Camshaft Chain Guide ⑪.

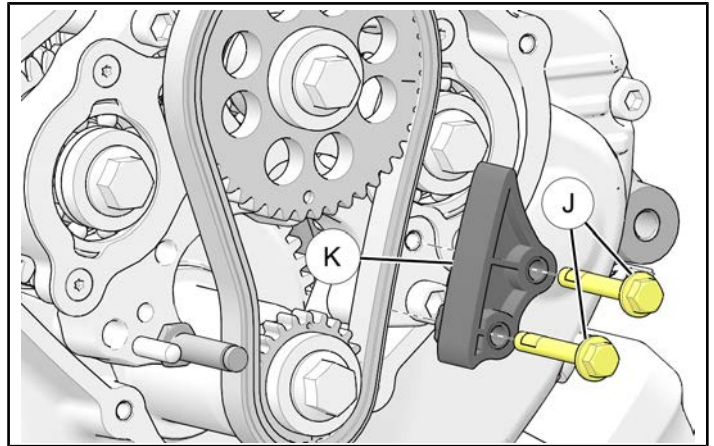

7. Remove screws ① and washers ⑬ from crankshaft and camshaft. Pull camshaft sprocket ⑭, crankshaft sprocket ⑮ and cam chain ⑯ off as an assembly and set aside. Collect woodruff key ⑰ from crankshaft and set aside.

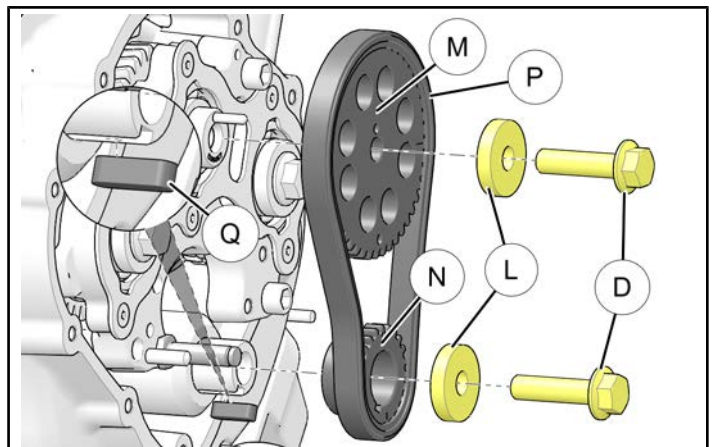

REMOVE AND INSTALL CAMSHAFTS

IMPORTANT

Camshaft removal with cylinder heads torqued in place requires Special Tool: **PF-51455**

1. Remove and install camshafts as per service manual procedure "**CAMSHAFT SERVICE - IN BIKE**"
2. Install new camshafts ③, ④, and ⑤ with retained woodruff keys and new screws ⑥ as per service manual procedure.

TORQUE

Camshaft Screws ⑥:
52 ft-lbs (70 N·m)

TORQUE

Camshaft Carrier Fasteners:
15 ft-lbs (20 N·m)

CAM CHAIN INSTALLATION

CAUTION

Thunder Stroke is an **INTERFERENCE ENGINE**. If camshafts and crankshaft must be turned independently of each other to set valve timing, camshafts must be set to TDC prior to rotating crankshaft. Failure to do this may cause pistons to contact valve resulting in engine damage.

1. Verify camshafts are set to TDC.
 - a. Camshaft timing marks ① and ② should be aligned as shown. Camshaft sprocket alignment dowel ③ should be at 12 o'clock as shown.

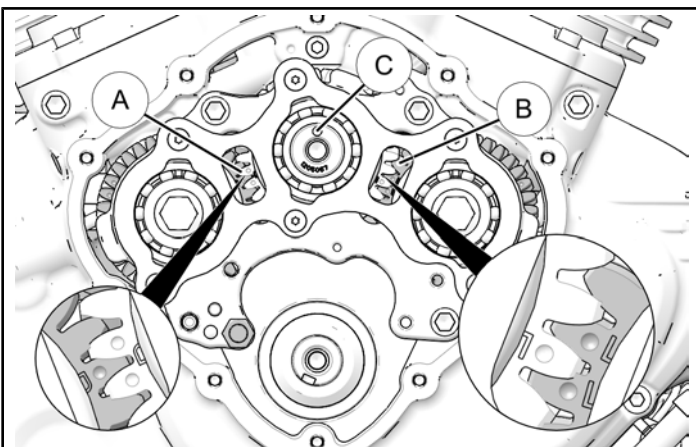

2. Assemble timing chain onto camshaft and crankshaft sprockets.
 - a. Align timing marks ④ as shown.
 - b. Position chain so dark chain links line up with sprocket hashmarks as shown.

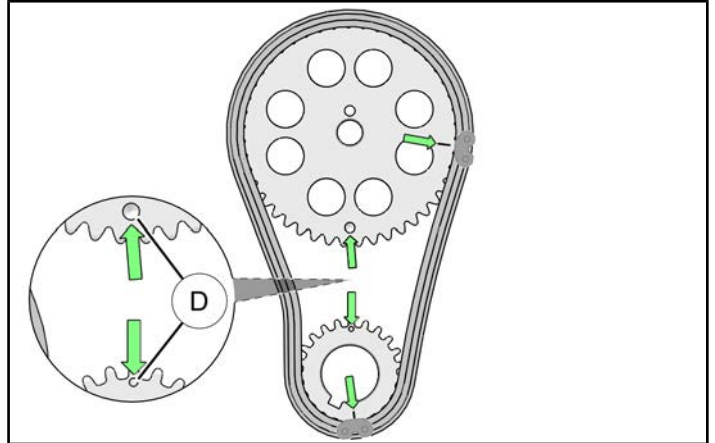

3. Slide chain and sprocket assembly onto crankshaft and center camshaft.
4. Verify crankshaft woodruff key ⑤ is in place and timing marks are aligned.

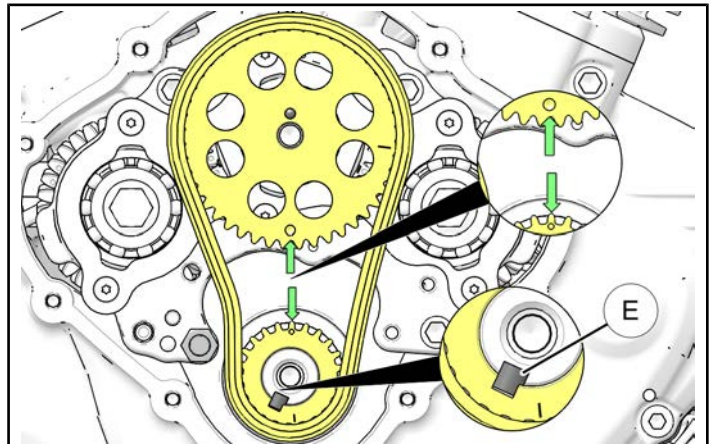

5. Install retained crankshaft and camshaft sprocket fasteners and washer and torque to specification.

TORQUE

Sprocket Screws:
52 ft-lbs (70 N·m)

6. Install retained cam chain guide and torque fasteners to specification.

TORQUE

Cam Chain Guide Screws ①:
71 in-lbs (8 N·m)

- Install retained cam chain tensioner and tensioner arm assemblies. Torque to specification.

TORQUE

Cam Chain Tensioner Arm Screw (E):
15 ft-lbs (20 N·m)

- Clean gasket mating surfaces and install retained cam chain cover with new gasket (7). Torque screws to specification using the following torque sequence.

TORQUE

Cam Chain Cover Screw (A):
10 ft-lbs (13 N·m)

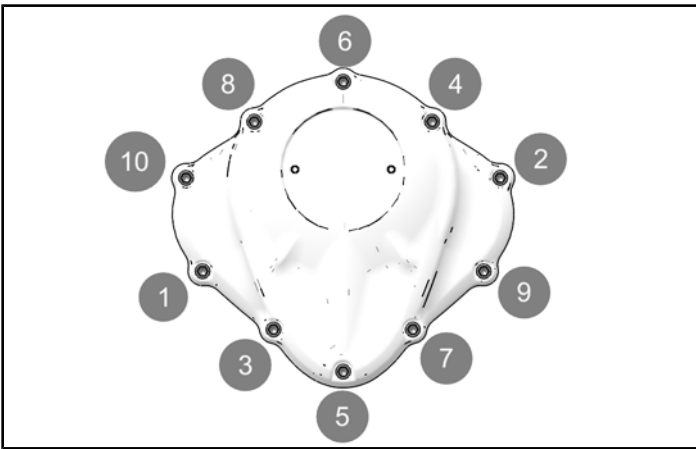

AIRBOX/THROTTLE BODY INSTALLATION

- Install retained bracket (A) with four retain fasteners (B). Torque fasteners to specification.

TORQUE

Bracket Fasteners (B):
88 in-lbs (10 N·m)

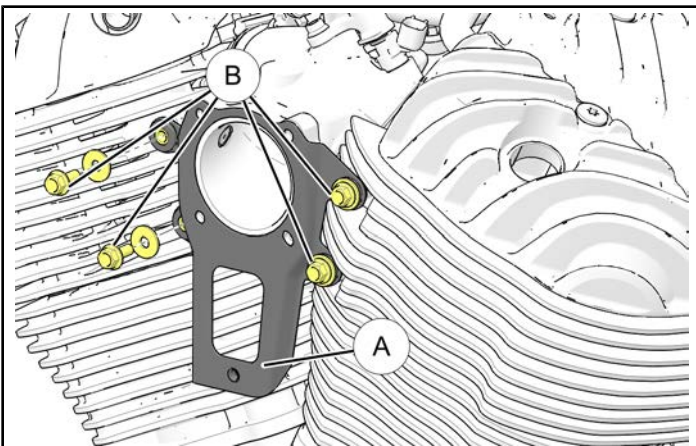

- Before installing **Stage 1 High Performance Air Cleaner Kit** (PN 2881779-XXX). Remove and discard hard plastic spacer (X).

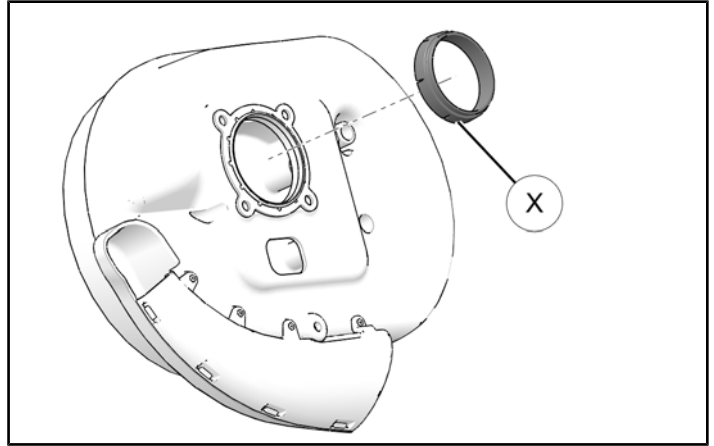

- Feed throttle body electrical connector (C) through hole in airbox (D) and install rubber harness seal (E) in rectangular cutout.

NOTE

Ensure harness seal is fully seated in airbox.

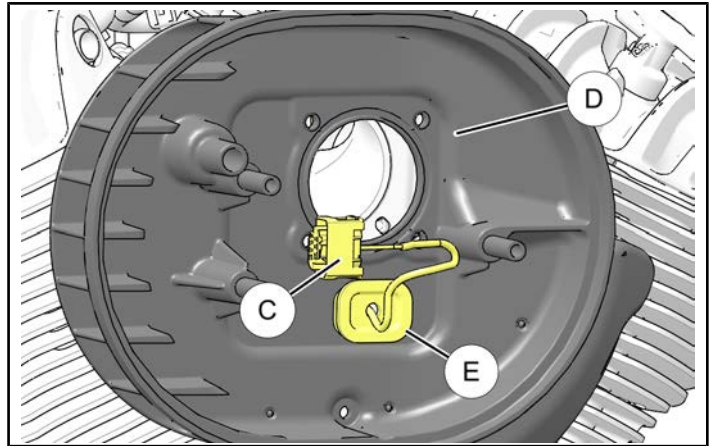

IMPORTANT

Ensure proper airbox gasket is used with corresponding airbox.

- Stage 1 High Performance Air Cleaner Kit (PN 2881779-XXX) (Oval Airbox)
 - Airbox Gasket (N) PN 5633638 (Included in Airbox Kit)
- Performance Airbox Kit (PN 2880654-XXX) (Round Airbox)
 - Airbox Gasket (19) PN 5633754 (Included in Stage 3 116 Kit PN 2883921)

4. Install new airbox gasket (19) or (N) with inner gasket lip extending into intake (as shown with inset and arrow) between intake manifold and airbox (D) (Airbox may vary from image based on which kit is equipped). Loosely install airbox (D) to intake manifold. Ensure breather hose (F) is connected to airbox (D).

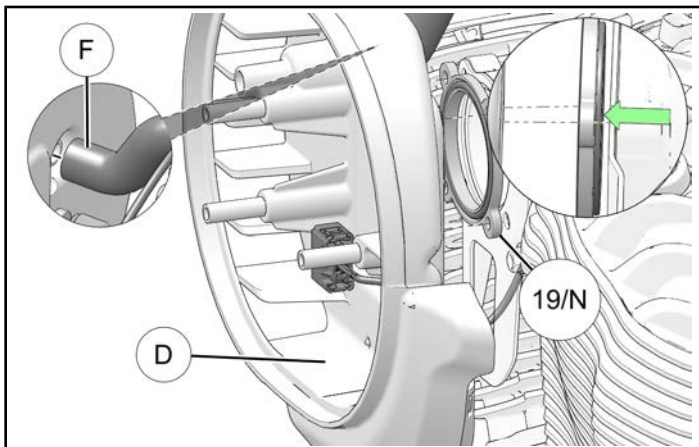

5. Install retained throttle body gasket (G) and new throttle body (2) using four retained screws (H). Plug throttle valve connector (C) into throttle valve. Torque screws to specification.

TORQUE

Throttle Valve Screws (H):
88 in-lbs (10 N·m)

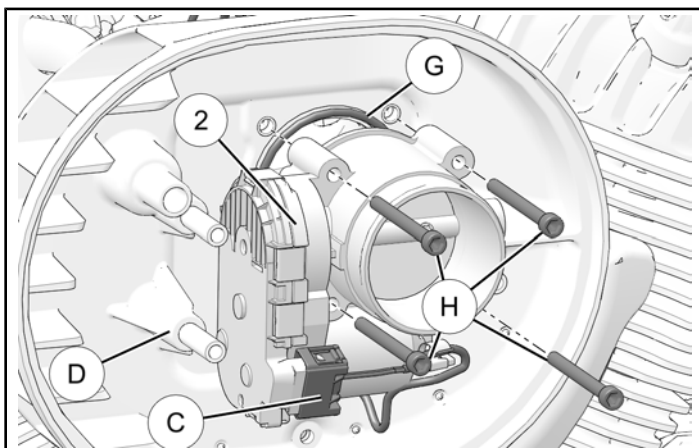

6. Complete installation of airbox using kit instructions for equipped airbox (PN 2881779-XXX or 2880654-XXX)

VEHICLE REASSEMBLY

RIGHT FLOORBOARD INSTALLATION

1. Hold floorboard assembly (F) in place and secure with two retained screws (E). Torque screws to specification.

TORQUE

Floorboard assembly screws (E):
35 ft-lbs (47 N·m)

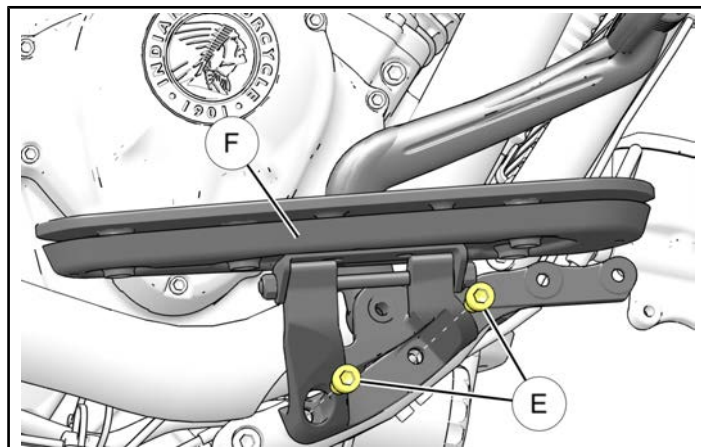

2. Lower brake master cylinder (D) in place, engaging pushrod onto brake pedal assembly and secure with two retained screws (C). Torque screws to specification.

CAUTION

Do not bend or kink flexible brake line during floorboard removal. Master cylinder assembly should be kept in an upright position and properly supported at all times.

TORQUE

Brake Master Cylinder Mounting Screws (C):
18 ft-lbs (24 N·m)

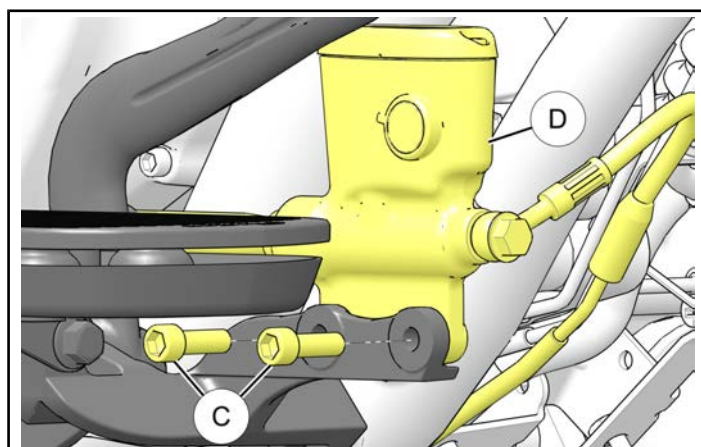

3. Apply a thin coat of grease to pushrod pivot pin and install retained washer **(B)** and cotter pin **(A)** onto brake master cylinder pushrod.

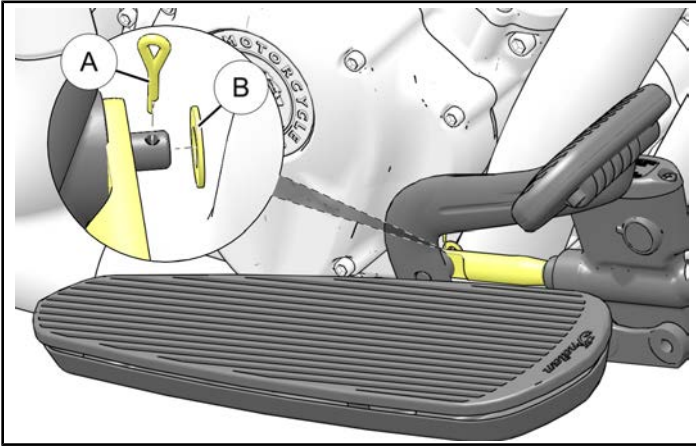

4. Test foot brake and verify pedal feels firm and no air has entered hydraulic circuit. Bleed brakes if necessary.

GENERAL

1. Reconnect any ignition wires, hoses, or any other connections on top of engine.
2. Reassemble any components removed for installation procedure as per service manual.

IMPORTANT

Ensure wire routings are clear of sharp edges and heat sources when installing. Refer to notes taken during disassembly and reinstall **ALL** cable ties and clips to original locations.

NOTE

Stage 1 Muffler Kit must be installed and not stock exhaust.

FEEDBACK FORM

A feedback form has been created for the installer to provide any comments, questions or concerns about the installation instructions. The form is viewable on mobile devices by scanning the QR code or by clicking [HERE](#) if viewing on a PC.



3. Replace engine oil and filter as per service manual procedure.
4. Check and top up oil as per service manual procedure.
5. Reconnect battery as per owner's manual.
6. Remove spark plugs.
7. Turn engine over several times with starter motor to pump up oil into engine.
8. Reinstall and torque spark plugs.

TORQUE

Spark Plugs:
13 ft-lbs (17 N·m)

9. Reinstall upper and lower side covers, saddlebags and seat as per owner's manual.

UPDATE ECM

UPDATE ECM

1. Update ECM with new calibration software using included Calibration Card **(10)**.

IMPORTANT

This step must be completed by an Authorized Indian Dealer. Do not operate vehicle until re-calibration of vehicle is complete.