



SOLOSiren®

Long Range Ultrasonic Level Monitor



Accurate Wireless Ultrasonic Level Monitor

Great for Monitoring Level from Manholes or Bridges

Wireless Data Transmission

Rugged Field Case

Lightweight, Highly Portable Compact Design

Self-Sustaining, User Replaceable Battery System

Technical Specifications:

Dimensions: 9.84" x 6.12" x 2.89"

Weight: 5 lbs.

Enclosure: ABS / PC / TPU

Power: Logger Input: 3.3V DC
Sensor Input: 12V DC

Battery: Rechargeable Battery Pack

Input: Single Sensor - Analog, Serial, Digital or Pulse

Data Storage: Internal Flash Memory, 88000 Sensor Readings

Sampling Rate: User Defined: 1 Minute Minimum (Standard)
1 Second Minimum (Optional)

Alarming: User Defined Data Point Threshold

Wireless: 4G LTE Worldwide Cellular Modem

SMS Alarming: Optional with Single Point Blind Alarm

Software Interface: FieldSIREN™ Proprietary Field Software
(Included free with every purchase.)

Data Interface: BlueLive® Cloud Based Big Data Hosting, FTP,
Drop Box®, Google Drive®

Temperature: -40°C to 60°C (-40°F to 140°F)

SOLOSiren®

The SOLOSiren® will provide you with accurate insight into your environmental data collection program without breaking the budget. Designed by field technicians with over 20 years experience, it's rugged, tough, and user-friendly.

With sensor options to meet the demand of today's environmental monitoring challenges, the SOLOSiren® is the go-to device for short term, fast turn-around data acquisition.

With the combination of an ultra-low power microprocessor and a user replaceable power pack, the SOLOSiren® will provide up to six months of data acquisition on a single charge.

With simplified user definable sampling, alarm, and data transmission rates, know the condition of your site in near real-time.



ALL PRODUCT, PRODUCT SPECIFICATIONS AND DATA ARE SUBJECT TO CHANGE WITHOUT NOTICE TO IMPROVE RELIABILITY, FUNCTION, DESIGN OR OTHERWISE. ... It shall be the customer's responsibility to validate that a particular product with the properties described in the product specification is suitable for use in a particular application.



Industrial Long Range Ultrasonic Level Sensor Product Specification Sheet

Measure Overflow Depths Manholes and CSO Chambers

Pre-Calibrated for Water Level Detection

Long Range Measurement from 8 inches to 20 ft

Submersible Design

Smart Signal vs Level Detection and Correction when used with Blue Siren Loggers.

Accurately measure from 8 inches (200mm) up to 20ft (6m). Great for ponds, lakes, and manhole monitoring.

Digital output with signal strength information allows the monitor to determine if a reading is good or not. Smart digital processing allows for the elimination of unwanted data commonly associated with non-contact sensors.

All sensors provide precision measurement for wastewater and water flow with non-uniform surfaces by incorporating state-of-the-art transducer technology and processing algorithms.

Technical Specifications:

Body Material: Rugged PVC

Accuracy: +/- 0.1% Measurement Accuracy

Beam Angle: 8° Conical

Operating Voltage: 12V DC

Temp. Compensation: Yes

Resolution: 11 Bit

Range: Dead-Band: 8in (200mm)
Maximum Range: 20ft (6m)

Response Time: 60 mS

Sampling Rate: 10 Samples Per Second

Temperature Range: -40°C to 70°C

Relative Humidity: 0 to 95%, non-condensing

Enclosure Rating: IP68

Range Accuracy: 0.01in (0.25 mm) Measuring Resolution

ALL PRODUCT, PRODUCT SPECIFICATIONS AND DATA ARE SUBJECT TO CHANGE WITHOUT NOTICE TO IMPROVE RELIABILITY, FUNCTION, DESIGN OR OTHERWISE. ... It shall be the customer's responsibility to validate that a particular product with the properties described in the product specification is suitable for use in a particular application.

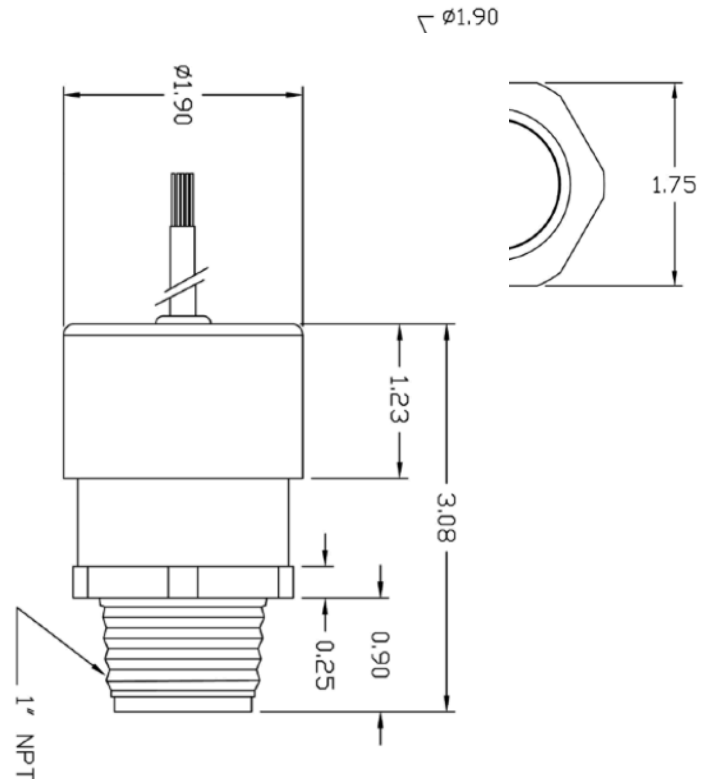

DATA MANAGEMENT

Wireless Cloud Delivery and Data Analysis

View and Analyze Real Time Data

Automatic Delivery to Hosting Provider of your choice, DropBox®, Google Drive®, FTP, email, BlueLive®

Batch View Line and Scatter Plots

Manage Large Networks

Multiple End Users, No Additional Fees



FLEXIBLE DATA PLAN AND DELIVERY OPTIONS:

Automatically upload monitor data to BlueLive®, DropBox®, GoogleDrive®, email, or a FTP location of your choice. The internal worldwide 4G LTE wireless module supports multiple countries and cellular frequencies. In addition, WiFi connectivity options also available for infrastructure implementation. Provide your own SIM card and cellular network or have Blue Siren provide one for you. Blue Siren has low cost options on major networks such as AT&T® and Verizon Wireless®.

Graphical Analysis	Line Graph Batch Analysis	Scatter Plot Batch Analysis	Data Export	Wiifat Export	GIS Analytics	Monitor Map	Wireless Report	Alarm Report	Alarm Setup	Email Config	Data Upload	Settings	Site Info
Multi-Layered Line Graphs						Batch Report and ScatterPlots							
GIS, Google Maps, and Spatial Analysis Tools						Image vs Data Correlation and TimeLapse							

ALL PRODUCT, PRODUCT SPECIFICATIONS AND DATA ARE SUBJECT TO CHANGE WITHOUT NOTICE TO IMPROVE RELIABILITY, FUNCTION OR DESIGN OR OTHERWISE. ... It shall be the customer's responsibility to validate that a particular product with the properties described in the product specification is suitable for use in a particular application.