



SCADASiren[™]

ULTRASONIC LEVEL MONITOR WIRELESS FLOWMETER

Wireless Commercial Grade Ultrasonic Level Monitor with Integrated Multimedia Vision Technology

Accurate 20 ft Ultrasonic Level Wireless Monitor

AC, DC or Solar Power Kits

Rugged Design with Clear View Window and LCD

Optional 4G or WiFi Wireless Connectivity

SCADASiren[™]

The SCADASiren[™] is a multi-application wall mount monitoring system with LCD and flow totalizer. Multiple SCADA output options are available including 4-20 mA, RS485, serial and analog output modules.

Optional USB allows for onsite data collection not requiring external connection to a field computer to collect data.

Automatically upload data for analysis to BlueLive[®] Cloud, DropBox[®], GoogleDrive[®] or FTP location of your choice. Future proof worldwide LTE wireless module supports multiple countries and cellular frequencies, WiFi option also supported.

Built-in multi-media platform allows direct connection of our vision camera taking simultaneous pictures that correlate directly with sensor readings. Receive alarm emails with not only critical data but also images supporting the condition.

Automatically upload data for analysis to BlueLive[®] Cloud, DropBox[®], GoogleDrive[®] or FTP location of your choice. Future proof worldwide LTE wireless module supports multiple countries and cellular frequencies, WiFi option also supported.

SPECIFICATION

Enclosure: 10 x 8 x 4in (HxWxD), wall mount, fiberglass reinforced polyester, gray, single-door, (2) twist-lock latches, SAR acrylic window.

Data Storage Internal Storage - 2.5 yr@15 min Sample Rate
USB - over 20 years

Total Images Internal Memory 500 (640x480) Images, USB over one million, Storage changes with image resolution"

Output: RS485, Sampler Pulse, LCD

Power: Logger: 3.3 V, Internal: 12 V, External: Max 16 V

Operating Temp. -40 to 60°C (-40 to 140°F)

Connectors: Spring Load Compression Fit

Power: Internal 12 V AC / DC Power Supply

Sample Rate: User Defined, 1 to 60 minutes

Software: Field-Siren Windows GUI, Cloud Programmable

Protocol: Compressed Binary

Wireless: World Wide Cellular: 4G LTE and WiFi

Data Transfer: Blue-Live[®] - DropBox[®] - GoogleDrive[®] - FTP

ALL PRODUCT, PRODUCT SPECIFICATIONS AND DATA ARE SUBJECT TO CHANGE WITHOUT NOTICE TO IMPROVE RELIABILITY, FUNCTION, DESIGN OR OTHERWISE. ... It shall be the customer's responsibility to validate that a particular product with the properties described in the product specification is suitable for use in a particular application.

Monitor With Vision[®]

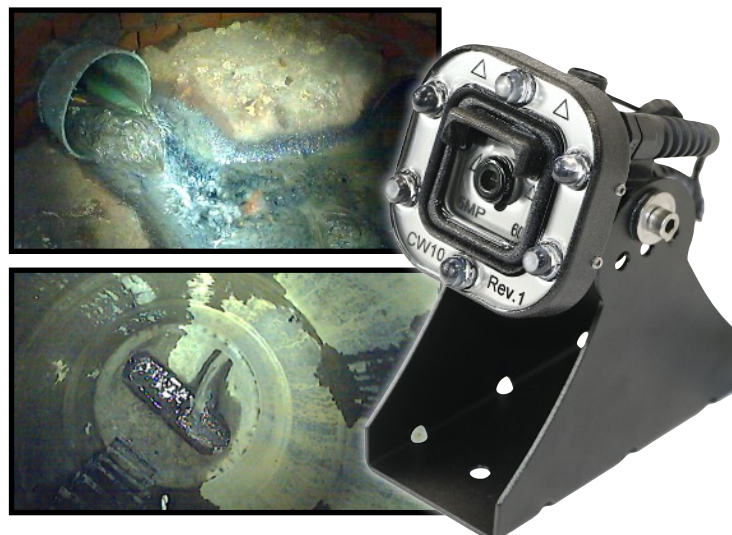



Industrial Long Range Ultrasonic Level Sensor Product Specification Sheet

Measure Overflow Depths Manholes and CSO Chambers

Pre-Calibrated for Water Level Detection

Long Range Measurement from 8 inches to 20 ft

Submersible Design

Smart Signal vs Level Detection and Correction when used with Blue Siren Loggers.

Accurately measure from 8 inches (200mm) up to 20ft (6m). Great for ponds, lakes, and manhole monitoring.

Digital output with signal strength information allows the monitor to determine if a reading is good or not. Smart digital processing allows for the elimination of unwanted data commonly associated with non-contact sensors.

All sensors provide precision measurement for wastewater and water flow with non-uniform surfaces by incorporating state-of-the-art transducer technology and processing algorithms.

Technical Specifications:

Body Material: Rugged PVC

Accuracy: +/- 0.1% Measurement Accuracy

Beam Angle: 8° Conical

Operating Voltage: 12V DC

Temp. Compensation: Yes

Resolution: 11 Bit

Range: Dead-Band: 8in (200mm)
Maximum Range: 20ft (6m)

Response Time: 60 mS

Sampling Rate: 10 Samples Per Second

Temperature Range: -40°C to 70°C

Relative Humidity: 0 to 95%, non-condensing

Enclosure Rating: IP68

Range Accuracy: 0.01in (0.25 mm) Measuring Resolution

ALL PRODUCT, PRODUCT SPECIFICATIONS AND DATA ARE SUBJECT TO CHANGE WITHOUT NOTICE TO IMPROVE RELIABILITY, FUNCTION, DESIGN OR OTHERWISE. ... It shall be the customer's responsibility to validate that a particular product with the properties described in the product specification is suitable for use in a particular application.

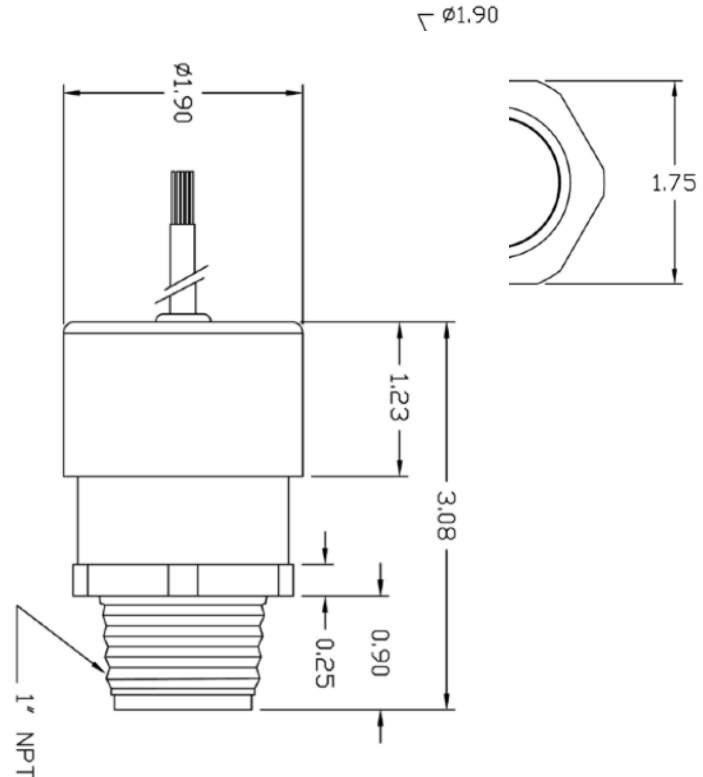



INDUSTRIAL 5MP VISION SENSOR

5MP Camera Sensor with High Output LED Ring

Multiple Resolution and Compression Settings

Maximum 5MP resolution

Built-in Compression

Encapsulated Electronics

Monitor With Vision®

The Blue Siren® 5MP high output LED Camera Sensor is great for thousands of applications: sewer pipes, grease clogging, inflow and infiltration problems, monitor storm grates and implement camera based infrastructure security.

Automatically store images and send them to any server or website. Subscribe to the BlueLive® Database and see your images as they upload. Sensor readings automatically correlate with image time stamps, allowing more in-depth analysis of system conditions.

The Camera Sensor is constructed using impact resistant urethane and encapsulated using optically clear epoxy. Air is fully vacuumed out of each sensor leaving no room for condensation or moisture.

Technical Specifications:

Pixel Resolution : 2592x1944 (Default), 2048x1536, 1920x1080, 1600x1200, 1280x960, 1024x768, 800x600, VGA, QVGA, 160x120

Sensor: 1/4" CMOS

Baud Rate: 115200bps (default), 19200bps, 38400bps, 57600bps, optional

Angle of View (FOV): 60 degree (default), 120/90/45/30/15/8 degree Optional

Focal Length: 3.6mm (default), 2.8mm/6mm/8mm/ 12mm/ 16mm/25mm Optional

White Balance: Automatic

Operating Temperature: -4°F-140°F

Sample Rate: Minimum 1 minute

Auto Gain Control: Automatic

Exposure: Automatic

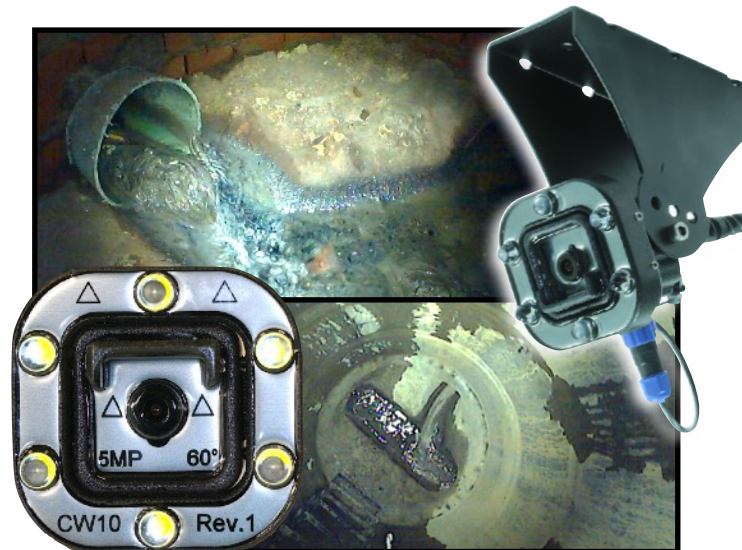

ALL PRODUCT, PRODUCT SPECIFICATIONS AND DATA ARE SUBJECT TO CHANGE WITHOUT NOTICE TO IMPROVE RELIABILITY, FUNCTION, DESIGN OR OTHERWISE. ... It shall be the customer's responsibility to validate that a particular product with the properties described in the product specification is suitable for use in a particular application.

DATA MANAGEMENT

Wireless Cloud Delivery and Data Analysis

View and Analyze Real Time Data

Automatic Delivery to Hosting Provider of your choice, DropBox®, Google Drive®, FTP, email, BlueLive®

Batch View Line and Scatter Plots

Manage Large Networks

Multiple End Users, No Additional Fees



FLEXIBLE DATA PLAN AND DELIVERY OPTIONS:

Automatically upload monitor data to BlueLive®, DropBox®, GoogleDrive®, email, or a FTP location of your choice. The internal worldwide 4G LTE wireless module supports multiple countries and cellular frequencies. In addition, WiFi connectivity options also available for infrastructure implementation. Provide your own SIM card and cellular network or have Blue Siren provide one for you. Blue Siren has low cost options on major networks such as AT&T® and Verizon Wireless®.



ALL PRODUCT, PRODUCT SPECIFICATIONS AND DATA ARE SUBJECT TO CHANGE WITHOUT NOTICE TO IMPROVE RELIABILITY, FUNCTION OR DESIGN OR OTHERWISE. ... It shall be the customer's responsibility to validate that a particular product with the properties described in the product specification is suitable for use in a particular application.