



Dimensions:	(Approximately) L: 12in W: 10in D: 5in
Enclosure:	Impact Proof Plastic
Data Storage	Internal Storage - 2.5 yr@15 min Sample Rate USB - over 20 years
Total Images	Internal max 255 Images, USB over one million * * changes with image resolution"
Output:	RS485, Sampler Pulse, LCD
Power:	Logger: 3.3 V, Internal: 12 V, External: Max 16 V
Operating Temp.	-40 to 60°C (-40 to 140°F)
Connectors:	Vision Port / 12 Channel Output Port External Wireless / Antenna Port 12 Channel Sensor Input Port Internal USB and Wireless Port
Battery Packs:	Internal Dual 12 V D-Cell Alkaline Power Supply
Sample Rate:	User Defined, 1 to 60 minutes
Software:	Field-Siren Windows GUI, Cloud Programmable
Protocol:	Compressed Binary
Wireless:	World Wide Cellular: 4G LTE and WiFi
Data Transfer:	Blue-Live® - DropBox® - GoogleDrive® - FTP

ALL PRODUCT, PRODUCT SPECIFICATIONS AND DATA ARE SUBJECT TO CHANGE WITHOUT NOTICE TO IMPROVE RELIABILITY, FUNCTION, DESIGN OR OTHERWISE. ... It shall be the customer's responsibility to validate that a particular product with the properties described in the product specification is suitable for use in a particular application.

ECOSiren®

NON-CONTACT RADAR FLOW WIRELESS FLOWMETER

Wireless Non Contact Flowmeter with Integrated Multimedia Vision Technology

Accurate Radar Level Wireless Monitoring Solution

Connect Multiple Sensors, up to 12 Channels

Full Face Radar Velocity Antenna

Modular Wireless Design allows 4G or WiFi Connectivity

ECOSiren® - Go ECO

The ECOSiren® is a multi-sensor autonomous wireless monitoring platform designed to work in the harshest conditions, delivering data to your desk every time. The built-in multi-media platform allows direct connection of our vision camera taking simultaneous pictures that correlate directly with sensor readings. Receive alarm emails with images showing the event details and severity.

Automatically upload data for analysis to BlueLive® Cloud, DropBox®, GoogleDrive® or FTP location of your choice. Future proof worldwide LTE wireless module supports multiple countries and cellular frequencies, WiFi option also supported.

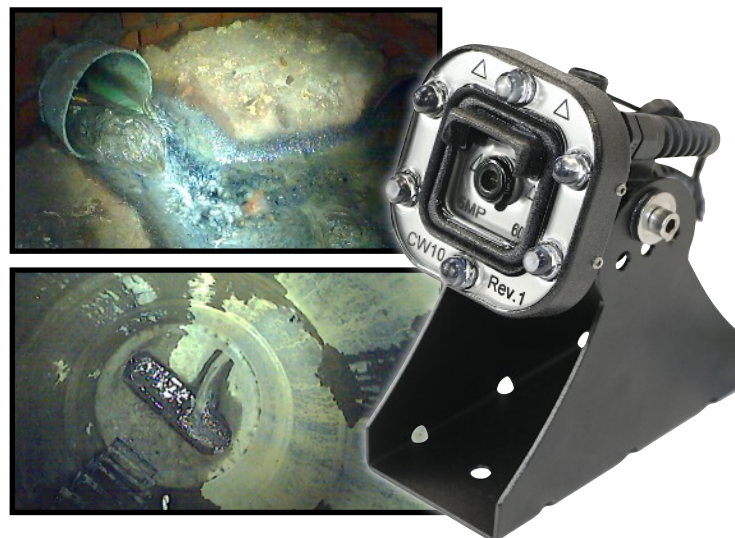

Monitor with Vision®

Each ECOSiren® monitor has a standardized camera port allowing you to monitor with vision® at any time. Great for overflow verification, industrial trade waste color, and Infiltration detection. Camera resolution can range from 5MP all the way down to 0.1MP, complete with user programmable compression.



Standardized Camera Port on Every ECOSiren® Monitor

Industrial Non-Contact Surface Velocity Radar Sensor Product Specification Sheet



Weight:	1.75lbs
Dimensions:	H= 6.125" W= 6.5" D= 1.5"
Frame Material:	ABS Polycarbonate Blend
Ambient Operating Temp. Range:	-30°C to 70°C (-22°F to 158°F)
Available Frequencies:	24.075 GHz - 24.175 GHz
Speed Measurements:	0.1 to 65 - feet-per-second (fps) 0.1 to 20 - meters-per-second (m/s)
Speed Range:	0.1-65 fps (0.1-20 m/s) 0.1-45 mph (0.1-70 km/h)
Accuracy	"100% accurate with a resolution of ± 0.10 unit of measure. (± 0.10 mph), (± 0.10 km/h), (± 0.10 feet-per-second) (± 0.10 meters-per-second) "
Maximum Humidity:	100%
Power Output (EIRP):	+20 dBm
Angle:	Includes cosine correction, allowing the unit to compensate for vertical and horizontal angles

Directional - Toward, Away, or Both

Compact Size

Narrow Beam Width

High Speed 24 GHz Sensor

Large Velocity Range 0 to 20 m/s approx. 60ft/s

Non-Contact Surface Velocity Sensor

SVR Surface Velocity sensor is designed to allow scientists to determine the surface velocity of water in open channels without having to install a sensor in the flow stream. Providing precise speed measurement from a stationary position outside the body of water this is an ideal sensor for hard to reach areas.

The sensor is extremely valuable for measuring water surface velocity during high-velocity flows and flood conditions where using contact measurement instruments poses a safety risk.

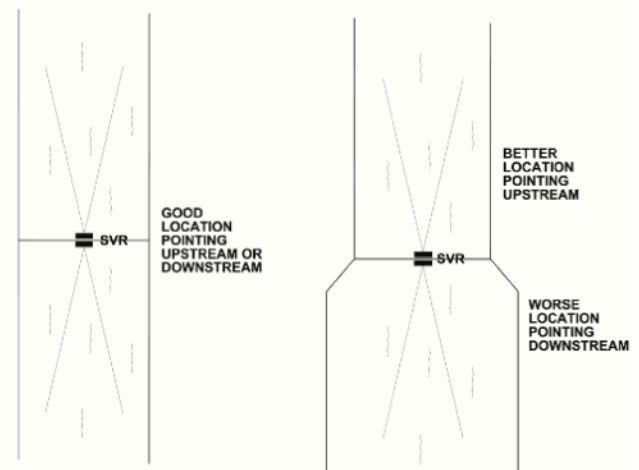

ALL PRODUCT, PRODUCT SPECIFICATIONS AND DATA ARE SUBJECT TO CHANGE WITHOUT NOTICE TO IMPROVE RELIABILITY, FUNCTION, DESIGN OR OTHERWISE. ... It shall be the customer's responsibility to validate that a particular product with the properties described in the product specification is suitable for use in a particular application.

LR50 RADAR LEVEL

Product Specification Sheet

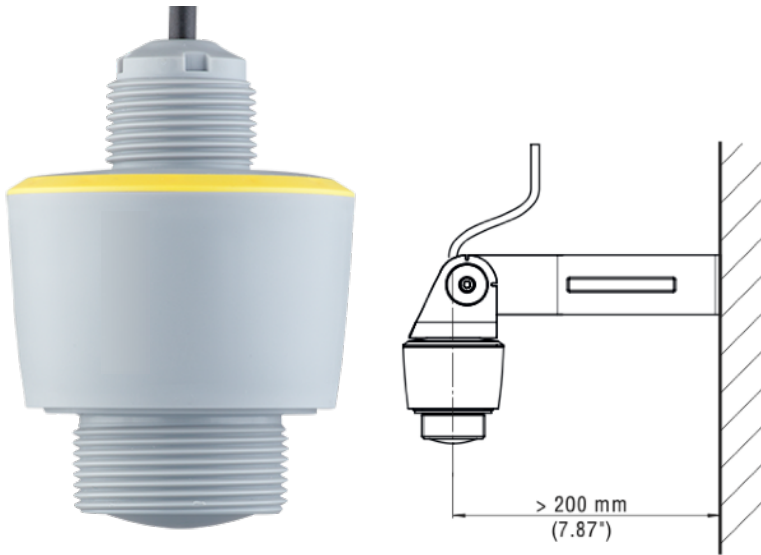

80 GHz technology

50ft Long range Accuracy with Resolution 1 mm

Zero (0) Dead Band

Rugged PVDF Material

Fast Response Time Saves Battery Life

LR50 RADAR LEVEL

Designed for use in water and wastewater applications, the LR50 radar sensor is our number one choice for non-contact level measurement. 80GHz radar technology is more reliable than conventional ultrasonic and leads to a more maintenance free operation.

Easily installed on a bracket, the LR50 can be mounted in manholes, pump stations, wet wells, bridges and other open channel level applications.

Long Range sensing technology will measure up to 50ft with a 0.07" accuracy.

Dimensions: Diam. 3" X 4.28"

Range: 0 to 15m ~ 50ft

Accuracy: 2 mm ~ 0.07 in

ENV Rating: IP66/IP68 (3 bar) acc. to IEC 60529, Type 6P acc. to UL 50

Beam Angle: 8°

Transducer: Radar

Material: PVDF

Response Time: ~ 3 seconds

W-band: 80 GHz technology

Resolution: 1mm (0.039in)

Blocking Distance: 0 mm (0 in)

SetUp: Bluetooth

Temperature: -40 to 80 C

Certifications: ATEX/IEC/c-FM-us/c-CSA-us; gas, intrinsic safety, Zone 0, 0/1, 1, 2 (Class I Division 1, 2) + Dust, intrinsic safety, Zone 20, 20/21, 21, 22 (Class II, III Division 1, 2)

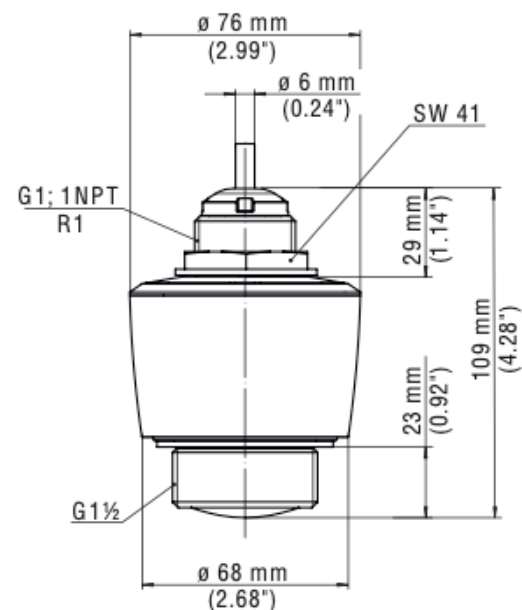

ALL PRODUCT, PRODUCT SPECIFICATIONS AND DATA ARE SUBJECT TO CHANGE WITHOUT NOTICE TO IMPROVE RELIABILITY, FUNCTION, DESIGN OR OTHERWISE. ... It shall be the customer's responsibility to validate that a particular product with the properties described in the product specification is suitable for use in a particular application.



INDUSTRIAL 5MP CAMERA SENSOR Optional VISION Sensor



Infrared LED Camera With Light Detection

Impact Resistant

Maximum 5MP resolution

Built-in Compression

Encapsulated Electronics

Monitor With Vision®

The Blue Siren® 5MP high output LED Camera Sensor is great for thousands of applications: sewer pipes, grease clogging, inflow and infiltration problems, monitor storm grates and implement camera based infrastructure security.

Automatically store images and send them to any server or website. Subscribe to the BlueLive® Database and see your images as they upload. Sensor readings automatically correlate with image time stamps, allowing more in-depth analysis of system conditions.

The Camera Sensor is constructed using impact resistant urethane and encapsulated using optically clear epoxy. Air is fully vacuumed out of each sensor leaving no room for condensation or moisture.

Technical Specifications:

Pixel Resolution : 2592x1944 (Default), 2048x1536, 1920x1080, 1600x1200, 1280x960, 1024x768, 800x600, VGA, QVGA, 160x120

Sensor: 1/4" CMOS

Baud Rate: 115200bps (default), 19200bps, 38400bps, 57600bps, optional

Angle of View (FOV): 60 degree (default), 120/90/45/30/15/8 degree Optional

Focal Length: 3.6mm (default), 2.8mm/6mm/8mm/ 12mm/ 16mm/25mm Optional

White Balance: Automatic

Operating Temperature: -4°F-140°F

Sample Rate: Minimum 1 minute

Auto Gain Control: Automatic

Exposure: Automatic

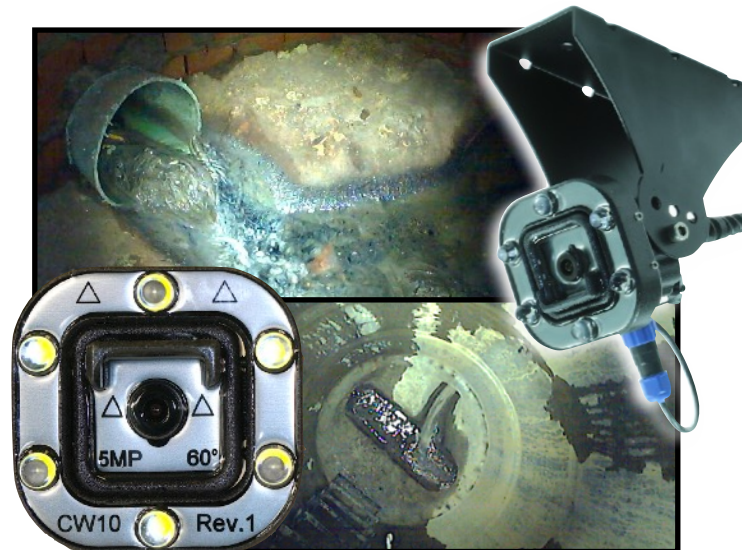

ALL PRODUCT, PRODUCT SPECIFICATIONS AND DATA ARE SUBJECT TO CHANGE WITHOUT NOTICE TO IMPROVE RELIABILITY, FUNCTION, DESIGN OR OTHERWISE. ... It shall be the customer's responsibility to validate that a particular product with the properties described in the product specification is suitable for use in a particular application.

DATA MANAGEMENT

Wireless Cloud Delivery and Data Analysis

View and Analyze Real Time Data

Automatic Delivery to Hosting Provider of your choice, DropBox®, Google Drive®, FTP, email, BlueLive®

Batch View Line and Scatter Plots

Manage Large Networks

Multiple End Users, No Additional Fees



FLEXIBLE DATA PLAN AND DELIVERY OPTIONS:

Automatically upload monitor data to BlueLive®, DropBox®, GoogleDrive®, email, or a FTP location of your choice. The internal worldwide 4G LTE wireless module supports multiple countries and cellular frequencies. In addition, WiFi connectivity options also available for infrastructure implementation. Provide your own SIM card and cellular network or have Blue Siren provide one for you. Blue Siren has low cost options on major networks such as AT&T® and Verizon Wireless®.



ALL PRODUCT, PRODUCT SPECIFICATIONS AND DATA ARE SUBJECT TO CHANGE WITHOUT NOTICE TO IMPROVE RELIABILITY, FUNCTION OR DESIGN OR OTHERWISE. ... It shall be the customer's responsibility to validate that a particular product with the properties described in the product specification is suitable for use in a particular application.