



# THANK YOU

for purchasing the #1 safe in America!



LIMITED LIFETIME WARRANTY

## USE & CARE MANUAL

To activate your LIFETIME WARRANTY go to

[WWW.LIBERTYSAFE.COM](http://WWW.LIBERTYSAFE.COM)

Click on the **REGISTER WARRANTY** button on the home page to complete registration and print out warranty confirmation.

*You will need the serial number of your safe to register*

## LIBERTY SAFE AND SECURITY PRODUCTS' LIMITED LIFETIME WARRANTY

**Limited Lifetime Warranty:** Liberty Safe and Security Products, Inc. (Liberty) is proud of the workmanship of the product you have just purchased. Liberty warrants that each new safe will be free from defects in material and workmanship for the lifetime of the original purchaser. If there is a defect in either materials or workmanship during your lifetime, we will repair or replace your safe at no cost to purchaser. Liberty will also repair or replace at no cost to the warranted party, any warranted safe that is damaged during a fire, break-in or break-in attempt during the lifetime of the original purchaser if the homeowner's insurance policy will not cover the damage. The lifetime warranty does not include the lock or painted surface.

**Lock and Painted Surface Warranty:** Locks and painted surfaces are warranted to be free from defects in workmanship and materials for a period of five years from the date of purchase.

**Electrical Items Warranty:** Light fixtures, transformers, cords, and light switches are warranted to be free from defects in workmanship and materials for a period of 1 year from the date of purchase.

*Liberty's obligation under the Limited Lifetime Warranty is limited to the repair (including labor) or replacement of any product that proves to be defective or damaged during a fire, break-in or break-in attempt, with a product of like size and type. Claims shall be made under this warranty by calling 800-247-5625 or writing to Liberty Safe and Security Products, 1199 West Utah Avenue, Payson, Utah 84651. Any claims made for fire, break-in or break-in attempts must be accompanied by a copy of your homeowners insurance statement of coverage, and a report made by the police. A claim must be made within six months of the break-in.*

*Liberty takes seriously its obligation to stand behind its product with this warranty as long as the safe is properly installed and cared for as instructed in the Owner's Use and Care Manual. The warranty does not apply to safes or parts that have been misused, neglected or subjected to unusual or extreme conditions and/or environments, or to unreasonable wear and tear. Changing or modifying the safe in ways that affect its intended use will void this warranty.*

*As a special service to you, the limited lifetime warranty can be transferred to subsequent purchasers or owners with the prior written consent from Liberty. Simply contact our Customer service team with your request. Liberty reserves the right to deny a request or transfer for any reason.*

**Limitation of Remedies:** In no case shall Liberty be liable for any special, incidental, or consequential damages based upon breach of warranty, breach of contract, negligence, strict tort, or any other legal theory. Such damages include, but are not limited to, loss of profits, loss of savings or revenue, loss of the contents of the safe or vault door, loss of use of the safe or vault door, or any associated equipment, cost of capital, cost of any substitute equipment, facilities or services, downtime, the claims of third parties including customers, and injury to property.

**Warranty Registration Card:** The attached registration card showing the serial number of the product and original purchaser information must be mailed to Liberty within thirty (30) days of purchase to validate this warranty. Online registration must also be completed within (30) days of purchase. Failure to register the product shall void any warranty.

**No Other Warranties:** This agreement is understood to be the complete and exclusive agreement between the parties, superseding all prior agreements, oral or written, and all other communications between the parties relating to the subject matter of this agreement. No employee of Liberty or any other party is authorized to make any warranty in addition to those made in this agreement.

**THIS WARRANTY PERTAINS ONLY TO THE LIBERTY SAFE ITSELF, AND DOES NOT EXTEND TO THE CONTENTS OF THE SAFE. FOR OPTIMAL SECURITY AND PROTECTION, SAFES SHOULD BE BOLTED TO THE FLOOR. PLEASE REFER TO YOUR USE & CARE MANUAL FOR DETAILS ON ANCHORING YOUR SAFE TO THE FLOOR.**

**Disclaimer of Warranty:**

**THE ABOVE WARRANTY IS IN LIEU OF ALL OTHER WARRANTIES EXPRESSED OR IMPLIED, INCLUDING WARRANTIES OF MERCHANTABILITY AND FITNESS FOR A PARTICULAR PURPOSE, WHICH EXTENDS BEYOND THE WARRANTY SPECIFIED ABOVE, AND IN NO EVENT SHALL THIS WARRANTY BE DEEMED TO COVER INCIDENTAL OR CONSEQUENTIAL DAMAGES OF ANY KIND.**

**Venue and Choice of Law:** Any claims arising from this limited warranty shall be resolved in the State of Utah and Utah law will apply to any dispute.

**Congratulations** on your purchase of your new high quality security safe designed and built by America's #1 gun safe company—Liberty Safe! To insure proper set up and installation, **PLEASE READ THIS USE AND CARE MANUAL** before opening your safe.



## **SAFETY PRECAUTIONS**

The safe door is heavy. Do not open the door with the safe on an uneven or unstable floor. Hanging on an open door may cause the safe to tip forward when not lag-bolted to the floor, resulting in serious injury or death to yourself or others. If you have or have occasion to have small children in your home, please make sure you never leave your safe unsecured. It is possible for small children to climb inside your safe and become locked in. This could result in serious injury or death.

## **PACKAGING MATERIALS**

After opening the safe, remove the plastic protectors or foam in the corners of the door. The fire seal is covered with a thin protective film. Please remove film before using the safe. (Note: Do NOT remove any part of the black rigid fire seal)

## **INSPECT YOUR SAFE**

Inspect your safe for shipping damage as soon as you receive it. If you find any damage, please contact the delivery company (or carrier) immediately. Any damage not noted upon delivery must be reported within fifteen (15) days or there will be no recourse.

## **SERIAL NUMBER & MASTER COMBINATION** (See opening instructions before proceeding)

**i** PLEASE NOTE: If your safe has been installed with an S&G Electronic Lock, use the Electronic Lock Opening Instructions on page 8 before proceeding.

place serial number  
and combination here

Your safe's **serial number** is located in two (2) locations on the safe. One is located on the top of the safe, back right side. The second is located inside the opening edge of the door. Compare the serial number in this manual with the serial number on the safe. All serial numbers should match. If they do not, contact your local dealer or Liberty Safe immediately. **You will need your safe serial number when contacting customer service about your safe.**

**i** PLEASE NOTE: Record your safe's serial number and combination and store in a secure location **OTHER THAN YOUR SAFE**. (For storage suggestions see lost combination sec.)

## **MANUAL LOCK—OPENING INSTRUCTIONS (FIRST TIME)**

The combination lock on your safe has been set randomly at the factory. Most safes come standard with a key-locking dial. To unlock the dial, insert the dial key and turn the key a half a turn clockwise. Turn the dial to the right (clockwise). The dial should stop at about "87". Turn safe handle and open door. **With door open**, you can now verify your combination.

**i** PLEASE NOTE: If the dial does not stop at "87" and continues to spin freely, the lock has been activated and you will need to open the combination (see paragraph on page 5 named LOCK—OPENING INSTRUCTIONS) with the door closed.

**TABLE OF CONTENTS**

Warranty.....1

Safety Precautions.....2

Serial Number and Combination.....2

Product Diagram.....4

Manual Lock—Opening Instructions.....7

S&G Titan PivotBolt Electronic Lock—Opening Instructions.....8

S&G Titan Direct-Drive Electronic Lock – Opening Instructions.....9

S&G Electronic Locks—Changing Combinations.....10

S&G Electronic Locks—Add or Delete Codes.....10

NL Electronic Lock – Opening Instructions.....11

NL Electronic Locks—Changing Combinations.....11

All Electronic Lock—Battery Replacement.....12

Moving Your Safe.....13

Removing the Safe from Pallet.....13

Placement of Your Safe.....13

Anchoring Your Safe.....14

Door Adjustment.....14

Loading Your Safe.....15

Cleaning and Maintaining Your Safe.....15

Lost Combination and Keys.....16

Online Combination Storage.....16

Troubleshooting Guide.....16

Frequently Asked Questions.....19

Warranty Claims and Repairs.....19

Available Accessories.....21

**Large Safe Outside**

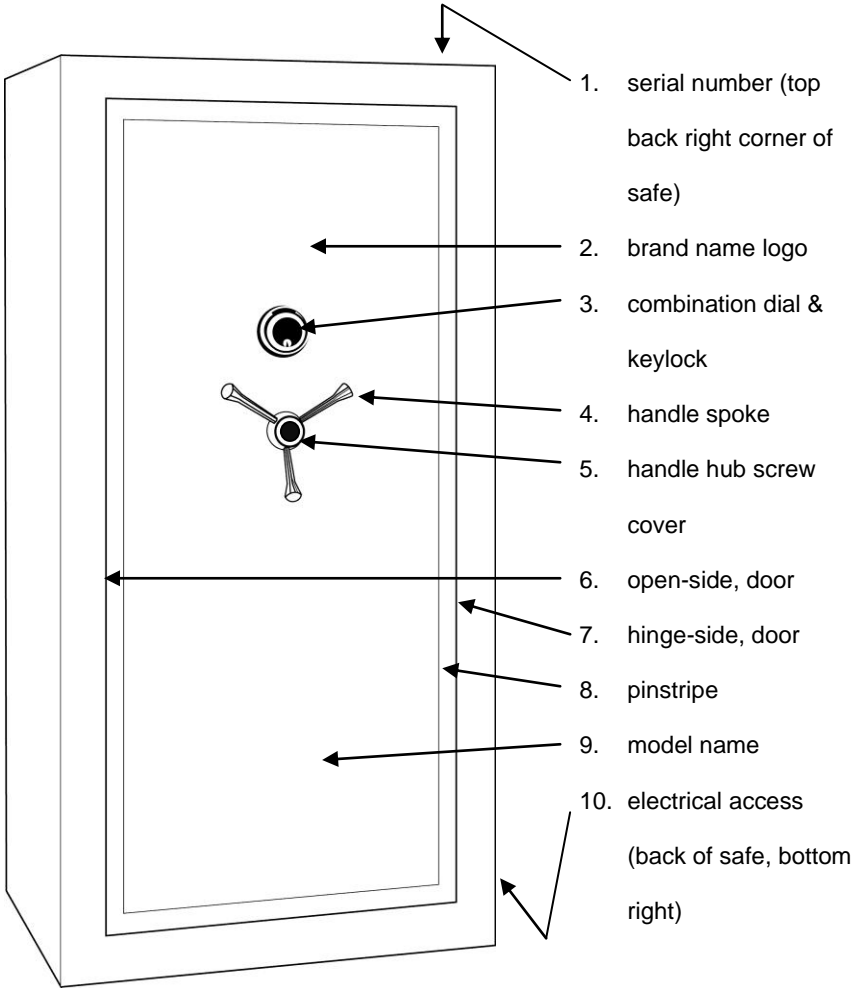

**Large Safe Inside**

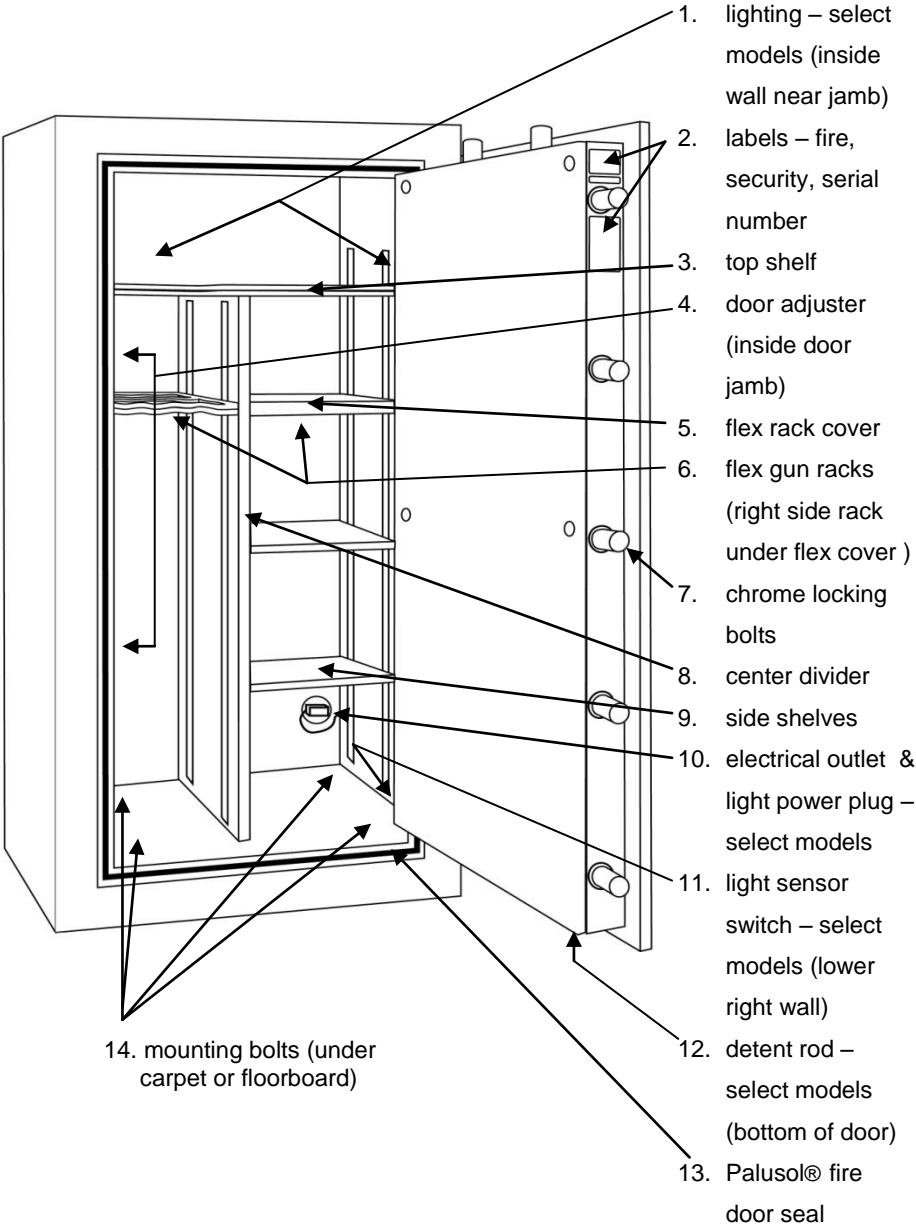

**Small Safe**

1. serial number (top of safe, back right corner)
2. S&G 6120 model electronic lock
3. handle screw cover
4. handle
5. hinges

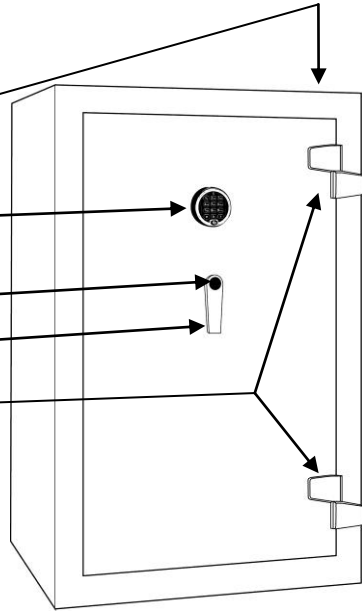

1. serial number, fire, and UL labels (top edge inside door)
2. executive shelf
3. locking bar
4. lock-out bolt hole
5. Palusol® fire seal
6. mounting bolts (under carpet)

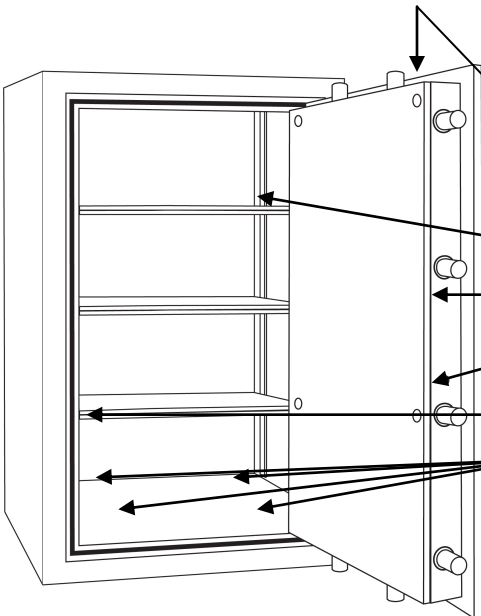

**EXTENDING BOLTS BEFORE VERIFYING COMBINATION**

It is preferred to verify your safe combination **with the door open**. If there are problems, it is easier to service the lock or mechanism with the door open. Before verifying your combination, you will need to extend the door bolts while the door is open. Keep door open. You can now verify your combination.

**VERIFYING THE COMBINATION**

The combination lock on your safe has been set randomly at the factory. After completely dialing the combination provided with your safe, turn the safe handle and open door. With the door open it is recommended that you verify the combination opens a few times before using the safe. It is also strongly recommended to do this after moving the safe.

**LOCK—OPENING INSTRUCTIONS**

The lock requires accurate alignment with the index mark (located at twelve noon on the dial ring). Always turn the dial slowly and steadily when entering your combination to avoid dialing past your numbers. **Never spin the dial rapidly back and forth as this may cause damage to the lock.** If you go past any number – even if by only a half a number – the entire combination must be re-dialed. To verify your combination, follow the four steps below. Copy your combination numbers from page 1 to the spaces below.



**Step 1**  
Turn the dial counterclockwise (LEFT) at least 4 times stopping on the 1<sup>st</sup> number at the index mark.

1<sup>st</sup> # \_\_\_\_\_



**Step 2**  
Turn the dial clockwise (RIGHT) passing the 2<sup>nd</sup> number twice. Stop on it the 3<sup>rd</sup> time.

2<sup>nd</sup> # \_\_\_\_\_



**Step 3**  
Turn the dial counterclockwise (LEFT) passing the 3<sup>rd</sup> number once. Stop on it the 2<sup>nd</sup> time.

3<sup>rd</sup> # \_\_\_\_\_



**Step 4**  
Turn the dial clockwise (RIGHT) until the dial stops (about 87). You will feel some resistance at about 95. Keep turning until the dial completely stops at about 87.

**Step 5** – If combination is entered correctly, you will be able to easily turn the safe handle and open the safe.



**IF COMBINATION DOES NOT WORK, DO NOT CLOSE DOOR! Try Again. Refer to the TROUBLE SHOOTING GUIDE in the back of this manual for more help.**

**USING THE KEY-LOCK (DAY-LOCK) FEATURE**



**PLEASE NOTE:** The Key-lock will prevent the dial from being turned to open the safe. However, to obtain the highest level of security it is recommended to lock the safe using the combination and key-lock together rather than the key-lock alone.



**USING THE KEY-LOCK (DAY-LOCK) FEATURE (CONTINUED)**

Before using the key-lock feature you will need to close the door and rotate the handle until the bolts extend into their locked position.

Step 1. Rotate the dial to the number 0.

Step 2. Insert the key and turn it 180 degrees counterclockwise until it stops (the jagged edge of the key should be facing up).

Step 3. Remove the key and verify the safe is locked by trying to turn the handle.

NOTE: If the safe is NOT locked, try rotating the dial counterclockwise to the number 4 and then back clockwise to 0, then repeat steps 2-3.

**CHANGING COMBINATIONS ON MANUAL LOCKS**

It is inadvisable for anyone other than a CERTIFIED LOCKSMITH to change the combination on a manual lock. Changing the combination by anyone other than a certified technician will void the lock portion of your warranty. Call your dealer or Customer Service Representative at Liberty Safe (800) 247-5625, press 0, for help locating an approved locksmith. As part of our continuing service, a record of your combination by serial number is kept on file at Liberty Safe. If you lose your combination it can be restored to you for a \$25.00 research fee provided you have informed Liberty of any combination changes and you have also met the documentation requirements. See the Lost Combination and Key section of this manual for more details and information about storing your combination.

**Electronic Locks**

Your safe may have one of the following two model electronic locks. Be sure to choose the correct model instructions before attempting to use your electronic safe lock.

**TITAN PIVOTBOLT ELECTRONIC LOCKS—OPENING INSTRUCTIONS**

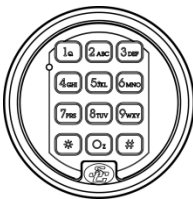

**⚠ WARNING!** All Electronic locks are set at the factory to 123456 #. For security purposes, you should change this combination to your own, new combination number. (See instructions below)

**⚠** Before entering your electronic lock combination, center the handle between left and right stop points. **If the handle or locking mechanism is putting pressure on the lock, it may not open.**

**⚠** Before entering your electronic lock combination, remove any static charge you may have by touching your finger to the body of the safe. **Discharging static electricity into the lock can damage it and prevent proper operation.**

**Opening your PIVOTBOLT electronic lock for the first time**

Enter the factory set 6 digit master combination (1,2,3,4,5,6 ) **followed by the pound (#) sign.** When each number is pressed, the lock will chirp and the red LED on the keypad will momentarily light up. After pressing the # sign, you should hear the lock retract inside the door, indicating the lock has opened and it is okay to turn the handle and open the safe door. You have **6 seconds** to turn the handle. If you wait longer than 6 seconds, the lock will re-lock and you will need to enter the code again. If you experience any problems opening your safe, refer to the Trouble Shooting section in this manual. If you pause more than 10 seconds between each number the lock will assume you do not wish to continue and will reset itself. If you press an incorrect button when entering the code, press the star ( \* ) button and start again with the first number in the code.

## Opening your PivotBolt electronic lock for the first time (cont.)

As a security feature, if 4 incorrect codes are entered in a row, your lock will stop accepting combinations for a period up to 10 minutes. To lock your safe, close the door and turn the handle until it stops. You should hear the lock 'click' indicating the lock bolt has dropped into place. Check by trying to turn the handle.

## TITAN DIRECT-DRIVE ELECTRONIC LOCKS – OPENING INSTRUCTIONS



**⚠ WARNING!** All Electronic locks are set at the factory to 123456 #. For security purposes, you should change this combination to your own, new combination number. (See instructions below)

**⚠** Before entering your electronic lock combination, center the handle between left and right stop points. **If the handle or locking mechanism is putting pressure on the lock, it may not open.**

**⚠** Before entering your electronic lock combination, remove any static charge you may have by touching your finger to the body of the safe. **Discharging static electricity into the lock can damage it and prevent proper operation.**

## Opening your Direct-Drive electronic lock for the first time

Make sure the keypad is turned counterclockwise to stop, the button is positioned under the locked pad lock symbol. Enter the factory set 6 digit master combination (1 2 3 4 5 6 ), followed by #. Then, within six seconds, turn the keypad clockwise about 70 degrees (2 o'clock position), until it comes to a positive stop, the button will be positioned under the unlocked pad lock symbol. **Do not put any pressure on the safe handle until after the keypad has been turned.**

## To lock your safe

Close the door and turn the handle until it stops. Turn the keypad counterclockwise until it stops and the button is positioned under the locked padlock symbol. The keypad will chirp twice and you will hear the lock click to lock the safe.

**⚠** **When turning the keypad to lock the safe, make sure to listen for the double beep that indicates that the lock has indeed successfully locked.**









## **⚠ WARNING!** Please keep door open when changing Electronic Combination!

After you have changed the combination on your electronic lock to your own unique combination, please keep it in a safe place other than inside the safe.

## CHANGING COMBINATION ON ELECTRONIC LOCKS

All code change procedures begin by pressing **2 2 \***, followed by the existing six-digit existing code and the pound ( # ) sign. If you are changing your combination for the first time your master combination will be (1 2 3 4 5 6) and your ID will be 0. When entered properly, the lock immediately chirps (  ) **five times**. If the lock emits a series of closely spaced chirps (almost a continuous tone) you have made a mistake and must start again. Note: Always keep safe door open with the lock in the locked position when making programming changes so you can verify that your new combination works before closing the safe door.









**TO CHANGE AN EXISTING CODE**

Press **2 2 \*** ( \_\_\_\_\_ # )     ( \_\_\_\_\_ # )   ( \_\_\_\_\_ # )  

existing code                      new code                      new code

After each time the pound (#) key is pressed, the lock chirps to acknowledge the entry. Wait for the chirps before proceeding. If a long series of closely spaced chirps (almost a continuous tone) sounds after pound (#) key is pressed, the new user code will not be accepted and the old code will remain. You will need to start over.









For example, if you want to set a new code to a code of 4 4 6 6 3 3 and the existing code is 1 2 3 4 5 6, you will use the following procedure:

Press **2 2 \*** ( **1 2 3 4 5 6 #** )     ( **4 4 6 6 3 3 #** )   ( **4 4 6 6 3 3 #** )  

existing code                      new code                      new code

This procedure will change or set the existing code to: 4 4 6 6 3 3

**TO ADD ADDITIONAL CODES (Supervisor or User Code)**









Press **7 4 \*** ( \_\_\_\_\_ # )     ( **1-9** ) # ( \_\_\_\_\_ # )   ( \_\_\_\_\_ # )  

Master/Supervisor code                      user ID                      new code                      new code

*PIN Positions: 1 Supervisor Code (note that a Supervisor Code can only be created by the holder of the Master Code.) 2 – 9 User Codes*

**TO DELETE A USER or SUPERVISOR CODE**









You may find that a particular user code is no longer needed. It is a good security practice to remove any unused codes. The master code is required to perform this step. The master code is the code the lock was originally set to when the safe was new from the factory (1 2 3 4 5 6). If you changed this code, then you changed the master code and your existing code is the new master code. User ID's are 1 – 9. The master code cannot delete itself. To delete a user code, follow this procedure:

Press **S G \*** ( \_\_\_\_\_ # )     ( user ID 1 thru 9 ) #   #  

(7 4)                      existing master code

After each time the pound (#) key is pressed, the lock chirps to acknowledge the entry. Wait for the chirps before proceeding. If a long series of closely spaced chirps (almost a continuous tone) sounds after pound (#) key is pressed, this indicates an error has occurred. The lock will automatically revert to the old code. Begin again at step one. For a copy of the complete programming instructions for the S&G Titan PivotBolt S&G Titan Direct-Drive Electronic Lock call Customer Support at **(800) 247-5625 and Press 0** or visit [www.libertysafe.com](http://www.libertysafe.com) and go to the Services & Support section of the website.

**TO ADJUST THE KEYPAD BEEPER VOLUME**

**7 8 \*** ( MASTER CODE # )     volume value #   volume value #  

Note: volume value is 0 for "OFF" OR 1 for "LOW" OR 2 for "HIGH".



# Register online at [www.libertysafe.com/warranty](http://www.libertysafe.com/warranty)

To register, you will need your serial number. Make sure the serial number in your owner's manual is the same as the serial number on your safe (inside door frame or on top/back of safe). If it does not match, please contact technical support at 1-800-247-5625. Liberty will not sell or publish your warranty information.

REQUIRED FOR REGISTRATION

Date of Purchase \_\_\_\_\_ Purchase Price \$ \_\_\_\_\_

What type of safe did you buy?  Home, Gun & Fire  Vault Door  Small Commercial Safe

Enter Serial Number \_\_\_\_\_  
L \_\_\_\_\_ (6 or 9 digit) F \_\_\_\_\_ (6 digit) LIT \_\_\_\_\_ (8 digit)

Was safe purchased for a business?  Yes  No

Company Name \_\_\_\_\_

First Name \_\_\_\_\_ Last Name \_\_\_\_\_

Male  Female

Secondary First Name \_\_\_\_\_ Secondary Last Name \* \_\_\_\_\_

\*Submitting a secondary name authorizes them to obtain lost combination and warranty requests.

Address \_\_\_\_\_

City \_\_\_\_\_ Country \_\_\_\_\_

State/Prov \_\_\_\_\_ Zip/Postal \_\_\_\_\_

Phone \_\_\_\_\_ Other Phone \_\_\_\_\_

Email \_\_\_\_\_

Product Updates  I would like to receive product information updates from Liberty Safe

1. Did your safe arrive in good condition?

Yes  No Comments on condition: \_\_\_\_\_

2. Was your safe delivered by the retailer? 3. Cost of Delivery

Yes  No \$ \_\_\_\_\_

4. How would you rate the delivery service:  Excellent  Very Good  Good  Fair  Poor

Comments on delivery: \_\_\_\_\_

5. How is the quality and function of your safe?  Excellent  Very Good  Good  Fair  Poor

Comments on quality: \_\_\_\_\_

6. How was the retail store where you bought the safe?

Very Professional  Acceptable  Needs Improvement

**A. Safe display organized, Point of Sale materials set up and brochures available**

Very Professional  Acceptable  Needs Improvement

**B. Helpful and knowledgeable sales staff**

Very Professional  Acceptable  Needs Improvement

**C. Selection of models and colors**

Very Professional  Acceptable  Needs Improvement

7. Based on your experience, would you recommend this retailer to others?

Yes  No Comments on retailer: \_\_\_\_\_

Your feedback and recommendations help us improve what we do.  
Thank you for making our safes #1 in the world.

**1. How did you first hear about our safes? (Check all that apply)**

- |  |  |   |   |  |
|--|--|---|---|--|
| <input type="checkbox"/> Website/internet                | <input type="checkbox"/> TV                  | <input type="checkbox"/> Friend/relative                  | <input type="checkbox"/> Radio              | <input type="checkbox"/> Saw safes at a retail store |
| <input type="checkbox"/> Magazine                        | <input type="checkbox"/> Trade show/gun show | <input type="checkbox"/> Mailer                           | <input type="checkbox"/> Newspaper/circular |  |
| <input type="checkbox"/> Glenn Beck Program              | <input type="checkbox"/> Dave Ramsey         | <input type="checkbox"/> Coast to Coast with George Noory |   |  |
| <input type="checkbox"/> Gun Talk radio with Tom Gresham | <input type="checkbox"/> Other: _____        |   |   |  |

**2. After you started looking at safes, how long did it take you to buy?**

- Less than a week     2-4 weeks     2-6 months     6-12 months     1 year or more

**3. What was the driving force behind buying a safe?**

**A. Protecting against crime / burglaries**

- Very Influential     Somewhat Influential     Little to No Impact

**B. Concern over the economy / financial instability**

- Very Influential     Somewhat Influential     Little to No Impact

**C. World conflicts / government direction**

- Very Influential     Somewhat Influential     Little to No Impact

**D. Securing firearms**

- Very Influential     Somewhat Influential     Little to No Impact

**E. Fire protection**

- Very Influential     Somewhat Influential     Little to No Impact

**F. Dealer / retailer advertising**

- Very Influential     Somewhat Influential     Little to No Impact

**G. Spouse wanted me to buy a safe**

- Very Influential     Somewhat Influential     Little to No Impact

**H. Any other reason?**

---

**4. Did you consider another brand before buying one of our safes?**

- Yes     No    If so, which brand(s): \_\_\_\_\_
- 

**5. What did you like about our safes that led you to choose us?**

---

**6. How influential were the following when buying one of our safes?**

**A. Liberty reputation**

- Very Influential     Somewhat Influential     Little to No Impact

**B. Lifetime warranty**

- Very Influential     Somewhat Influential     Little to No Impact

**C. Size / capacity / number of gun slots**

- Very Influential     Somewhat Influential     Little to No Impact

**D. Functionality / Flex™ interior**

- Very Influential     Somewhat Influential     Little to No Impact

**E. Price / promotion**

- Very Influential     Somewhat Influential     Little to No Impact

**F. Delivery service**

- Very Influential     Somewhat Influential     Little to No Impact

**G. Any other reason?**

---

**7. Did the following help you while you were shopping for a safe?**

**A. Website**

- Very Helpful     Somewhat Helpful     Little or No Impact

**B. Brochure**

- Very Helpful     Somewhat Helpful     Little or No Impact

**C. Sales Person**

- Very Helpful     Somewhat Helpful     Little or No Impact

**Comments:**

---

**8. Was the co-owner / spouse involved in the shopping process for a safe?**

- Yes     No

CONTINUED ON BACK

**9. Do you have any recommended improvements for our safes, accessories or services?**

---

---

---

---

---

**10. To help us with advertising, which radio stations do you like listening to? (Check all that apply)**

- News / Talk Radio     Sports Radio     Outdoor / Hunting Programs     Country  
 Rock n Roll     Pop     Other not listed

**11. Do you read any of these outdoor magazines? (Check all that apply)**

- American Rifleman     American Hunter     America's 1st Freedom  
 Bow Hunting     Buckmaster's Whitetail Magazine     Chevy Outdoors Sporting Journal  
 Field & Stream     "Game & Fish" Regional Magazines     Guns & Ammo  
 In-Fisherman     North American Hunter     Outdoor Life  
 Petersen's Hunting     Progressive Farmer     Successful Farming  
 Other Magazines \_\_\_\_\_

**12. Do you watch any of these outdoor TV shows? (Check all that apply)**

- Babe Winkelman     Backland Outdoors     Bill Jordan Realtree Outdoors  
 Buckmaster's Whitetail Magazine     Bushnell's Secrets of the Hunt     Great Outdoorsman  
 Hunting Adventures     Hunting with Hank     Jimmy Houston Outdoors  
 Midwest Outdoors     Mossy Oak Classics     North American Outdoors  
 Northwest Hunter     Oak's hunting of the Country     Outdoor Advantage  
 Outdoor Secrets     Outdoors with Archie Phillips     Paul Newsom's Great Outdoors  
 The Outdoor Channel     The Outdoorsman     The Sportsman Channel  
 Tony Dean Outdoors     Wild TV     ESPN  
 Other TV shows not listed above \_\_\_\_\_

**13. Year Born** \_\_\_\_\_

**Save time and money!**

**Register online to activate your warranty.**

**[www.libertysafe.com/warranty](http://www.libertysafe.com/warranty)**

To activate your warranty you must  
Register online at [www.libertysafe.com/warranty](http://www.libertysafe.com/warranty)  
or complete this cover card and mail to Liberty.

---

---

---

---

ATTN: WARRANTY REGISTRATION  
LIBERTY SAFE AND SECURITY PRODUCTS INC  
1199 WEST UTAH AVENUE  
PAYSON UT 84651-1744

PLACE  
STAMP  
HERE

SAVE A STAMP,  
REGISTER AT  
[WWW.LIBERTYSAFE.COM](http://WWW.LIBERTYSAFE.COM)



**CHANGING BATTERIES IN ELECTRONIC LOCKS**

Battery life is based on how much the electronic lock is used. The lock will emit several short chirps when battery power is getting low. S&G only recommends using **Duracell® 9V Alkaline Batteries** for best performance. The memory chip in the lock itself retains the lock codes (both master and user codes) during battery changes and even if the battery goes dead for an extended period of time. A **weak battery** may cause the lock to not open, even though beeps occur. Replace with fresh batteries at regular intervals to insure best performance.

**BATTERY REPLACEMENT – S&G PIVOTBOLT LOW PROFILE ELECTRONIC KEYPAD**



**Step 1**—Remove the battery tray from underneath the bottom of the keypad. Catch the small notch and pull the housing slightly toward the front of the keypad. Slide tray down and pull out and remove old battery.

**Step 3**—S&G recommends replacing the battery with a **Duracell® alkaline battery**. Notice the notches in top of battery compartment. Positive side of battery goes in square narrow slot and negative in wide rounded slot. Slide and click battery tray back into place.



**BATTERY REPLACEMENT – S&G DIRECT DRIVE ELECTRONIC KEYPAD**

**Step 1**—Pull the spring loaded button at the top of the keypad toward you slightly. It is not meant to separate from the keypad. Once out, carefully turn the keypad ring counterclockwise to stop. Then pull the ring away from its

base far enough to expose the battery compartment.

**Step 2**—Remove the old battery. Place your finger on the side of the old battery and slide it up and out. Disconnect the old battery.

**Step 3**—S&G strongly recommends **Duracell® alkaline batteries**. No matter what brand is used, the battery must be alkaline. Align the battery and connector terminals, and snap the battery to the connector.

**Step 4**—Carefully slide the battery behind the keypad (wires & connector face down), into the cavity that is designed to hold it. Be sure the battery has dropped all the way to the bottom of the cavity.

**Step 5**—Battery wires should not be showing. If they are, gently place them into the cavity. Make sure it is not in a position to be caught between the keypad ring and the keypad base when the ring is pushed back against the base.

**Step 6**—Once the battery and any wires are safely positioned out of harm's way, push the keypad ring back up against the base, then turn it clockwise until the button snaps back into its normal position. Check your lock operation at least three times with the safe door open before closing it.

**BATTERY REPLACEMENT – Loss Prevention NL Electronic Lock**



A series of signals indicates that the battery is weak and must be replaced. Use only 9V ALKALINE—batteries! The battery compartment is located at the bottom of the entry unit.

## MOVING YOUR SAFE



### SAFETY PRECAUTIONS

Before moving you safe, make sure you have completely tested the combination and lock to assure it will open properly prior to removing the safe from the pallet and to its final location. Safe doors are NOT designed to be removed due to possible serious injury. Never



### SAFETY PRECAUTIONS (cont.)

move the safe with the door open. Do not open the door with safe lying down. The safe's door should never be removed. Safes are very heavy and awkward to handle. Only use of proper moving equipment by a trained professional is recommended. Using a standard refrigerator dolly is very dangerous and can cause injury or death.

## REMOVING THE SAFE FROM PALLET

(NOTE: If you want help to have the pallet removed and the safe installed as described below, contact your local Liberty dealer.)

With the safe upright and open, pry up the black plastic caps on the floor to expose the mounting bolts (note: some models require you to lift the access panels or carpet on the floor to expose the black plastic caps). Use a 9/16" socket and ratchet to remove the bolts. **Caution: Have someone steady the safe while removing the safe from the pallet to prevent the safe from tipping forward.** Close and key-lock the door to prevent accidental opening while removing the safe from the pallet to the final location (it is not recommended to scramble the combination). Make sure you have adequate help to move the safe off its pallet. Carefully slide the safe off the pallet until one edge is resting on the floor. While the safe is tilted on its edge, remove the pallet out from under the safe. Carefully lower the safe back to its upright position.

## PLACEMENT OF YOUR SAFE

Before moving your safe, verify the load bearing weight of the floors and stairs, and types of flooring the safe will be moved over (tile, wood, and other flooring can be damaged by the weight of the safe). We recommend placing a protective barrier (such as a piece of carpet, treated wood or rubber mat) between the safe and floor to prevent scratching of the safe surface, which could lead to rust. To determine whether or not your safe will make it through doorways, stairs or corners take the empty safe box and see if it will fit all the way through to its final location.



**Proper installation and anchoring are critical to the security and fire performance of your safe.** Make sure you consider the following:

- Install near a load-bearing wall as a precaution to supporting the weight of the safe.
- To help protect the exterior finish of your safe, install inside your home in a dry location where there is climate control (heat in the winter and cooling in the summer).
- Depending upon the fire safe you've purchased, it has been designed to withstand a certain amount of heat during a fire. The safe's fire rating depends upon the number of layers of fireboard and BTU rating. Generally speaking, fire safes perform better in lower levels of a home (like the basement) where fire temperatures are lower. Additionally, placement of your safe away from potential hot spots (areas where flammable materials are stored) will improve your chances that your safe and its contents will perform better in a home fire. No safe is completely fireproof. If the fire reaches a high enough temperature for long periods, fire damage may occur.
- To store photographs, negatives, CD's or other electronic media, a Media Cooler Storage unit inside your safe is recommended for heat sensitive items.

## ANCHORING YOUR SAFE

To achieve the highest level of security and safety possible, **anchor your safe securely to the floor.** We recommend placing a protective barrier (such as a piece of carpet, treated wood or rubber mat) between the safe and floor to prevent scratching of the safe surface, which could lead to rust. Before anchoring safe, make sure the safe is level. Use redwood door shims to adjust safe level so the door has the desired swing. Use appropriate hardware for the wood or cement surface you are anchoring to. Anchoring kits with instructions are available from your dealer. While most safes are UL Listed as Residential Security Containers (RSC), given enough time it is possible for a thief to break into a safe. Securing it to the floor helps secure and prevent removal of the safe by thieves.

## DOOR ADJUSTMENT

**Note: Safes with square locking bars (see diagram pg. 6) do not require door adjustment.**

Most safe models have two door adjusters for tightening or loosening the door. These adjusters are located just inside the safe on the left doorjamb. After removing all packaging material, close the door and extend the bolts. Pull out on the door handle to check the tightness. If there is play in the door, you will need to adjust the slide plate. Using the supplied hex wrench, loosen the two (2) hex adjuster screws. Slide the adjuster left to loosen and right to tighten the door. Re-tighten screws and check adjustment. When properly adjusted, you should feel slight resistance when turning the handle to extend the door bolts. Only slight movement should be felt with the door is shut. **Caution: Do not adjust door too tight. This may cause wear on both the door pins and locking mechanism. If your door has a tendency to self-open (the bolts retract by themselves) or the handle is hard to turn when extending the bolts, the door adjusters may be too tight.**

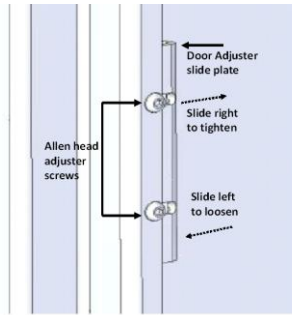

## USING & MAINTAINING YOUR SAFE

### ADJUSTING INTERIOR RACKS

**⚠ CAUTION:** Because gun racks are very fragile, we recommend **LIFTING ONE SIDE OF THE GUN RACK** (especially the EZ rack) when removing and re-installing the shelf (as shown below). **DO NOT PULL RACK STRAIGHT OUT.**

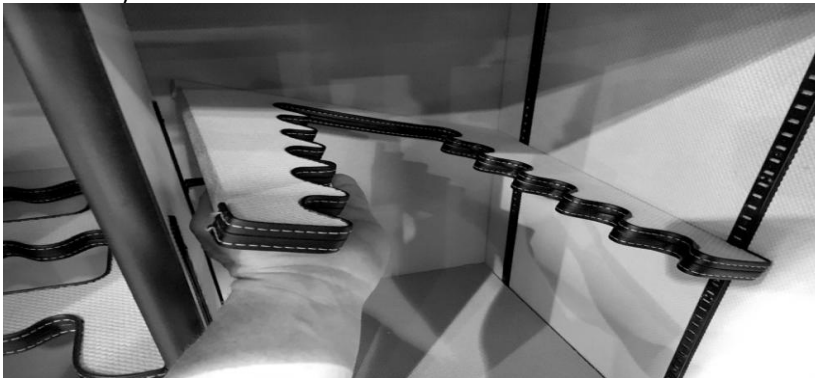

## **LOADING YOUR SAFE**

- When putting guns into your safe, make sure they rest securely against the cutouts provided to prevent accidental tipping when the door is closed.
- Store documents in the bottom of the safe for greatest protection against fire damage.
- Store ammunition separately from valuables.
- If you are storing electronic media, use a Media Cooler to provide additional protection (See your local dealer or visit [www.libertysafe.com](http://www.libertysafe.com)).
- Do not put anything in your safe that will put pressure against the door when it is closed.
- If you live in a humid environment, it is recommended that you use a **dehumidifier** or **desiccant** to protect the contents from rust or mildew. Dehumidifiers and other moisture reducing products suitable for your safe are available from your dealer. Dehumidifiers should be kept at least 1" away from side and back walls.
- Store heavy contents away from the middle of the shelf. Overloading shelves (46 + lbs.) can cause them to sag or break. Maximum weights vary by model. Contact Customer Support for complete details on max weights for each model.

## **ELECTRICAL OUTLET (Select Models)**

Electrical outlets are installed only on select model safes. Before using the outlet some assembly is required.

- Step 1. Locate the power cord on the inside of the safe on the floor. Attach the female side of the cord to the electrical access hole in the back of the safe (see diagram pg.5).
- Step 2. Plug the power cord into a home or office wall outlet.

## **CLEANING AND MAINTAINING YOUR SAFE**

- **Manual Locks** – It is recommended that you have your manual lock serviced annually by a certified lock technician to maintain trouble-free service. Electronic locks do not require this service.
- **Chrome Locking Pins** – Once per year extend the bolts and wipe a small amount of lubricating oil or Vaseline along the bottom of the middle most (2<sup>nd</sup>, 3<sup>rd</sup>, or 4<sup>th</sup> bolt down) bolt on the hinge and open side of the door.
- **Internal Locking Mechanism** – The advanced locking mechanism requires no maintenance. Opening the door panel of your safe by anyone other than a certified lock or safe technician may void your warranty.
- **Exterior** – Use a soft, non-abrasive cloth dampened with water to clean the surface of a gloss, powder coat or textured finish safe. Other materials may cloud or scratch the finish of your safe:
  - Logos and other graphic images must be wiped gently. Never rub or polish
  - The lock and handle have a protective coating to prevent tarnish. **DO NOT** use metal polishes or solvents for cleaning. Simply wipe off with a soft cloth.
  - Scratches and other blemishes may be touched up with a paint touch up kit available from your dealer.
- **Fire Seal** – The fire seal does not need maintenance unless it is ripped or destroyed. If the seal becomes damaged, call for replacement pieces. The Palusol<sup>®</sup> fire seal used provides additional fire protection. Once the temperature reaches 212° it expands up to seven (7) times its flat size and fills the joints and gaps resisting penetration of smoke and heat.

## LOST COMBINATION OR KEYS—ALL LOCK TYPES

The lock on your safe has been set with a randomly selected combination at the time of manufacturing. As part of our continuing service, a record of your combination by serial number is kept on file. To help us better serve you, please contact Customer Support at (800) 247-5625 when you change your combination or code.

If you lose your combination, you can retrieve a copy for a \$25.00 research fee, **provided you have not changed it from the original combination**. You must complete certain security and documentation requirements. If you lose your keys you can obtain a duplicate for \$5.00 each key, plus \$5.00 shipping and handling. Call (800) 247-5625, press 0, or go to [www.libertysafe.com](http://www.libertysafe.com) to download a combination/duplicate key request form. To use our Fax-on-Demand service and have forms faxed directly to you call (801) 465-5950.

## NEW! COMBO VAULT



Wish you could remember your combination when you really need it? Now you can! Introducing Liberty's COMBO VAULT retrieval system.

For no cost to you, this system allows you to store your combination through a special encrypted program where only you have access to the information you put in it. Combo Vault uses SSL encryption as well as proprietary security systems and methods to ensure your data is secure. To learn more visit [www.libertysafe.com](http://www.libertysafe.com).

## TROUBLESHOOTING GUIDE

<u>Problem</u>	<u>Possible Solution</u>
<b>Key Will Not Turn</b>	Verify that the combination dial is set at zero before attempting to turn the key. Make sure key is fully inserted before attempting to turn key.
<b>Combination Will Not Open the Safe</b>	Check lock-bolt pressure. Some free play should exist in the handle, left to right. Redial the complete combination stopping at "0" (before reaching "87"). Hold dial on "0" while rattling the handle left and right. Then turn the dial right until it stops at about "87". <b>PLEASE NOTE:</b> If your lock still does not open, it is possible that one or more of your numbers may be off slightly from those shown in this manual. The combination number may have shifted slightly during shipping. Try dialing 1 up or 1 down from each number in the combination. If it opens with a new number, update your combination in this book and report it to Liberty Safe (800) 247-5625, Press 0.
<b>Combination Opens the Safe Intermittently</b>	Check lock-bolt pressure. Some free play should exist in the handle, left to right. Try dialing the combination again. Bolt pressure may be due to out of place interior shelves or improper personal storage (i.e. gun barrels, items too big for shelves).

**TROUBLESHOOTING GUIDE (cont.)**

**Chrome Locking Bolts Do Not Retract to Close Door**      Verify that the dial is unlocked and has stopped on or about "87" before turning the handle. On models with electronic locks make sure the electronic lock is unlocked. Bolts may become dry and need oil. Use a cotton cloth and light oil to rub each bolt entirely, front & back of door.

**Combination Works But Handle Will Not Turn**      Verify that the dial has completely stopped (turning to the right) on or about "87" before turning the handle. Corner protectors (packaging material) may cause undue pressure on the locking bolts. To alleviate the pressure push in on the door while pulling out and turning the handle to open the safe. If the handle turns partially the bolts may be jammed or caught up. Try rotating the handle back and forth (left to right) until the bolts free up. Use a cotton cloth and light oil to rub each chrome locking bolt on the open and hinge side of the door.

**Combination Works and Handle Turns But Safe Will Not Open**      Verify that the handle has been completely rotated in the open position before opening the door. Check the **Allen set screw** located on the front (center of handle under sticker) or side of the handle hub for tightness. Some safes are installed with a unique handle clutch mechanism. Improper personal storage or over tightening the door adjusting mechanism may cause the clutch to temporarily engage. Try pushing in on the door while pulling out and turning the handle. You may have to repeat this step several times until door is open.

**Door Will Not Shut**      Verify that the lock is unlocked and the chrome locking bolts are fully retracted. Make sure the interior shelves are pushed back as far as possible, and that the floorboard is pressed down to the bottom of the safe floor. The handle should travel the same distance with the door closed as it does with the door open.

**Door Shuts But Will Not Lock**      Verify that the door is shut completely, the handle rotated completely and chrome locking bolts are extended to their locked position. Then rotate the dial to lock the safe. Verify that interior shelves are pushed back as far as possible, and that the floorboard is pressed down to the bottom of the safe floor. (For electronic locks see the next section.)

**Combination Dial Is Tight or Will Not Turn**      Verify that the key-lock is unlocked (jagged edge of key will be facing up) before attempting to turn dial. Check lock-bolt pressure. Some free play should exist in the handle, left to right. Bolt pressure may be due to out of place interior shelves or improper personal storage. Make sure the door is completely closed and the locking bolts are in the fully extended position. Normally dial tightness varies from safe to safe. Tightness of dial may increase or decrease as dial is being turned.

**TROUBLESHOOTING GUIDE (cont.)**

**Combination Works  
But Handle Will Not  
Turn**

Verify that the dial has completely stopped (turning to the right) on or about "87" before turning the handle. Corner protectors (packaging material) may cause undue pressure on the locking bolts. To alleviate the pressure push in on the door while pulling out and turning the handle to open the safe. If the handle turns partially the bolts may be jammed or caught up. Try rotating the handle back and forth (left to right) until the bolts free up. Use a cotton cloth and light oil to rub each chrome locking bolt on the open and hinge side of the door.

**Electronic lock will  
not open.**

1. The locking mechanism of a safe can, under certain conditions, place pressure on the side of the lock's bolt. This is often caused by something inside the safe pressing against the door or by something caught between the safe door and its frame. When this occurs, the lock will not operate properly. To relieve side pressure on the lock bolt, move the safe's handle to the fully locked position, (for direct-drive locks make sure the keypad is turned counterclockwise to stop), then re-enter a working code. The lock should open.
2. If the lock "chirps" when keys are pressed, but it will not open, the batteries may be drained to the point that they will not operate enough to open the lock. Follow the battery replacement procedure in this manual.

**Electronic lock will  
not lock.**

1. If the lock "chirps" when keys are pressed, but it will not open, the batteries may be drained to the point that they will not operate enough to lock the lock. Follow the battery replacement procedure in this manual.
2. For single battery keypads, the battery may not be making good contact with the keypad terminals. Try improving battery contact, removing the battery tray and bend down the two thin metal contact tabs located inside the battery tray compartment at the top. Then, enter your code a few times until lock begins to lock.
3. For D-Drive locks try the following.
  - i. Open the door all of the way and extend the bolts.
  - ii. Pull the keypad housing away from the door (similar to changing the batteries).
  - iii. Locate the spindle plate that rests against the safe door, directly behind the keypad.
  - iv. There are two ears (tips) on the plate that are positioned between 12 and 2 o'clock. Verify the door is open all of the way and the bolts are extended to their locked position. Slide the two ears counterclockwise to the 12 o'clock position. The lock should click and chirp once.
  - v. Try the handle, it should be locked.

## **FREQUENTLY ASKED QUESTIONS**

### **Q. How does the key-lock work?**

A. It is used to lock the dial from turning. You can lock the dial combination scrambled or open. Simply set the dial to "0", insert the key and turn half a turn counterclockwise. This will lock the safe. To unlock, turn the key half a turn clockwise, remove the key and either redial combo or turn dial back to opening position.

### **Q. Can I change the safe's combination?**

A. If the safe is equipped with an electronic lock refer to the "Changing Your Combination" instructions in this manual. (The S&G operating instructions for bio-metric locks are included in your packet as well). If the safe is equipped with a mechanical dial lock you must contact a locksmith or your local dealer to have the combination changed.

### **Q. Why is the handle pointing in a different direction than it used to be?**

A. The handle has a built in clutch mechanism. When the handle is forced it will slip left or right. To reset it simply force it back to its original position when locked.

### **Q. What is routine maintenance and who is qualified to do it?**

A. Routine maintenance keeps your safe's lock in good working condition and may prevent costly lockouts. Most locksmiths can perform the work. Make sure that they are familiar with Sargent & Greenleaf® group II locks. For your convenience a locksmith locator is available at [www.libertysafe.com](http://www.libertysafe.com) under the support section.

### **Q. What if I lose my keys or combination?**

A. A Duplicate Key/Combination request form must be filled out and faxed along with a copy of the sales receipt to: (801) 465-5940. You can print a form from our website [www.libertysafe.com](http://www.libertysafe.com) under the Services & Support section or have one mailed by calling our toll free customer service line at (800) 247-5625.

### **Q. Can an electronic lock be installed on the safe?**

A. Yes. Contact your dealer for details.

## **WARRANTY CLAIMS**

Please read carefully the safe warranty that accompanied your safe. If you encounter a problem that falls under the warranty coverage, simply call Customer Support at (800) 247-5625, press 0. You will be required to provide the serial number and proof of ownership if you have not sent in your warranty card.

## **WARRANTY REPAIRS**

Repairs to your safe covered under your warranty should not be performed without the pre-authorization of a Liberty customer service representative. If there are any issues regarding your safe please contact a Liberty Safe Customer Support at (800) 247-5625. Solutions to frequently asked questions and issues can also be found in Trouble Shooting Guide in this booklet or on line at [www.libertysafe.com](http://www.libertysafe.com). The cost of any repairs performed without pre-authorization will be the sole responsibility of the owner.



**WATER AND FIRE DAMAGE**

Your safe is not waterproof. Should your safe be exposed to water, the fire insulation of your safe will be compromised. Do not continue to store items in a safe that has been compromised by water. You should purchase a replacement model for continued fire protection. In the event of flooding or water damage, make sure to have your safe opened as quickly as possible. If your safe included firearms, remove them and have them cleaned and lubricated immediately. Damage to the safe from water alone is not included in the lifetime limited warranty.

**INSURANCE COVERAGE**

** LIBERTY SAFE DOES NOT INSURE THE CONTENTS OF YOUR SAFE.** A homeowners policy or other insurance coverage should be purchased in an amount sufficient to cover the contents. Most homeowners policies require the purchase of riders or endorsements on items such as guns, jewelry coins and other valuable collectibles. Should damage occur to your valuables, a claim should be made with your homeowners insurance. Check with your local insurance company for possible discounts that may be available with your purchase.

---

# ACCESSORIES

## Keep Your Valuables Dry



PEET® DRYER  
DEHUMIDIFIER  
10497



ELECTRIC DEHUMIDIFIER  
12"-9913 18"-10872



EVA-DRY  
9993



750 g DESICCANT  
CAN 2412



450 g DESICCANT BOX  
10826

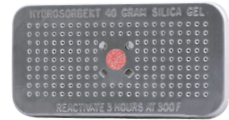

40 g DESICCANT  
MINI-CAN 10825

## Miscellaneous Accessories



MINI DUSTER  
10847



LIBERTY SAFE HAT  
13794

## Light Your Safe



**CLEARVIEW™ SAFE LIGHT (5 OR 6 WAND)**

5 Wand Kit-10792, 6 Wand Kit-10793



**BRIGHTVIEW™ SAFE LIGHTS (2 WANDS)**

10981



**SAFE SECURITY LIGHTS**

For E-locks-10930, Mech. Locks-10929

## Power Your Safe



Inside

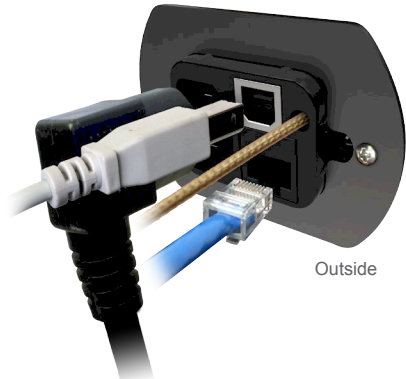

Outside

**POWER OUTLET KIT**

11015-001

## High-Security Electronic Locks

**LED LIGHT!**



**SARGENT & GREENLEAF™ EMP RESISTANT LOW-PROFILE E-LOCK**

(Factory installed option on all 20 CF & larger CO & RV models)

**LED LIGHT!**



**SARGENT & GREENLEAF™ EMP RESISTANT D-DRIVE E-LOCK (#1 SELLER!)**

(Factory installed option only on PX, NS, CL, LX and FR series)



**SARGENT & GREENLEAF™ BIOMETRIC LOCK**

(Factory installed option on PX, NS, CL and LX only.)

## Security Add-Ons



Liberty's SAFELERT adds another level of security in protecting your valuables and your family. SAFELERT sends up to 5 people a text or email if your Safe's security is ever compromised. Does it work? Recently a Liberty owner was on vacation when he received a "movement" alert. He called 911 and the police caught both thieves trying to break into his safe. Boy was he glad he had SAFELERT. Connects through your WiFi system.

**24 HR MONITORING  
NO MONTHLY FEES!  
UP TO 20 DEVICES ON 1 ACCOUNT!**



**OPENING/CLOSING OF SAFE DOOR**  
Know when others open and close your safe door



**SAFE MOVEMENT AND VIBRATION**  
Attempted break-ins and/or moving of safe



**INTERNET CONNECTION LOSS**  
Internet connection status checked every hour



**INTERNAL TEMPERATURE FLUCTUATION**  
Rise or fall of desired temperature



**MONITOR HUMIDITY LEVEL INSIDE SAFE**  
Alert on humidity level changes

**SEE HOW IT WORKS**  
SCAN QR CODE TO TRY IT NOW!



### ANCHORING KITS (best security add-on)



WOOD FLOOR ANCHORS  
10914



CONCRETE FLOOR ANCHORS  
10915

**DANGER! BLACK POWDER  
ENCLOSED-STICKER 10462**



## Handgun Storage



**HANDGUN HANGERS OVER/UNDER** (2 PACK)

10822



**HANDGUN HANGERS UNDER SHELF** (4 PACK)

10817



**HANDGUN HANGERS BACK/OVER** (2 PACK)

10921



**HANDGUN HANGERS BACK UNDER** (2 PACK)

13666



**4-GUN PISTOL RACK**

10956



**OAK PISTOL RACKS**

Beige-2414-001, Silver-2414-002

## Storage Solutions



**BOW HANGER**

11013



**MULTI-MAG** 13037



**JEWELRY DRAWER**

6.5"-10486A, 8.5"-10253A,  
11.5"-10254A, 15"-10255A



A.

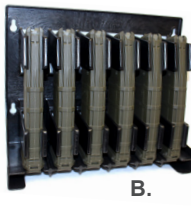

B.



C.

**MAGMOUNT & AR15 MAGSTORAGE**

A. Magmount-10958

B. AR15 Magstorage-13007

C. AR15 Magstorage Magnets-13596

## Storage Solutions



### RIFLE RODS STORAGE

RIFLE ROD KITS:

- Starter Kit - 20 Pack Rifle-10821
- Starter Kit - 10 Pack-10820
- Add-Ons - 6 Pack-10819
- Add-Ons 17 Cal - 2 Pack-10818



### AMMO CAN

5-Year Limited Warranty.

Dimensions: 59.5"x24.25"x22"

Each Shelf Section: 13.5" x 22.25" x 13.5"

Weight: 270 lbs. PN# 18-000-00B



### SAFE COVERS

20-25 Size: 13917    30-35 Size: 13918

48 Size: 13919    64 Size: 13921

50 Size: 13920



### MAGNET GUN CADDY

14550



### ACCESSORY DOOR PANEL SIZES

10583 Centurion 12 Gun Import  
(Internal Hinge Model)

10583A USA Centurion 12 Gun  
(External Hinge Model)

10584 Model 18

10585 Models 20-25

10586 Models 30/35/40

10587 Models 48/64

10588 Model 50



### EXTRA COOL POCKET®

Sold Separately 10597



### AMMO CANISTERS

.30 CAL 10933-30

.50 CAL 10933-50

---

**Handgun Vaults**

---

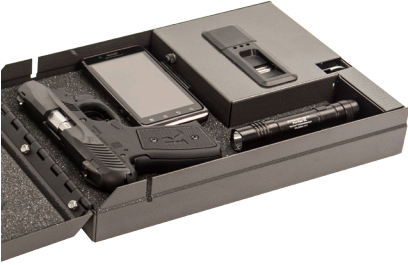

**HDX-150**



**HDX-250**



**HD-90**



**HD-100**



**HD-200**



**HD-300**



**OPTIONAL  
HDX-150  
AC ADAPTER**  
12592

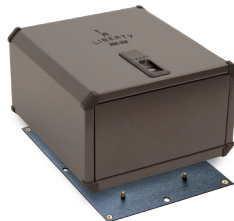

**OPTIONAL  
HDX-250  
MOUNTING  
BRACKET**  
12591



---

Register your **LIFETIME WARRANTY** online at:  
**WWW.LIBERTYSAFE.COM**

---



---

Copyright © 2017 Liberty Safe and Security Products, Inc.  
1199 West Utah Avenue Payson, UT 84651 • 800.247.5625

P/N 10831-12