

LIFESTYLE KIT

INSTALLATION MANUAL



GRIDFREE

LIFESTYLE KIT



 Installation of this kit legally requires an electrician.

We are always happy to help guide you through the install, troubleshoot, and answer any questions. You can contact us on 09 218 5533, or info@gridfree.store.

We recommend reading these instructions in full prior to starting your install.

KIT CONTENTS

1x 35mm² Cable 3m Pre-Crimped (Red+Black)



1x 16mm² Cable (Black) 1m Pre-Crimped (Red+Black)



2x 10m of 6mm² Solar PV Cable Set - MC4 (Female, Red + Male, Black)



11x 50mm² Battery Link Cable



4x 50mm² Battery to Battery Connection Cable 2m (Blue)



3x MC4 Solar Adapter Y Branch Connector Set



2x ANL Fuse & Fuse Holder 100A~150A



1x Solar Combiner Terminal Block

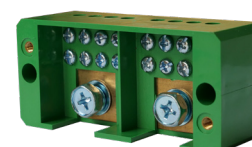

4x Leader Fuse



4x Leader Fuse Holder



1x 200A MCCB



1x Customized MCB Enclosure



2x DC Isolator



1x Growatt 5KW ES Hybrid Inverter



12x 12v200Ah Deep Cycle Gel Battery



12x PERC MONO Solar Panel

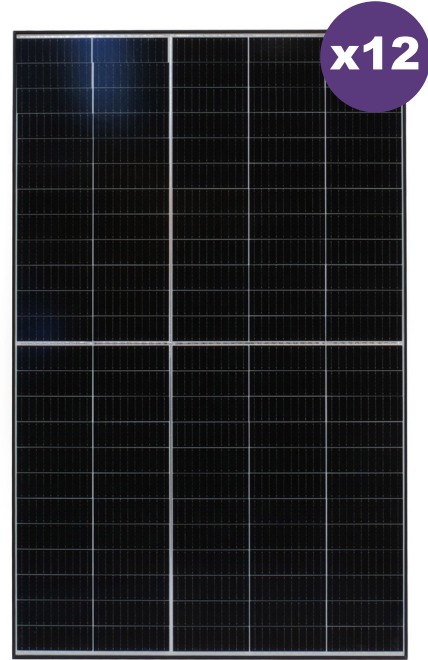

REQUIRED TOOLS

Drill



Screw Drivers

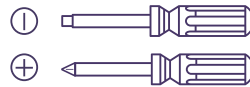

6mm Allen Key



Wire Strippers

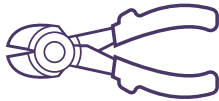

13mm Spanner



Socket Set



SOLAR MOUNTS

Ground



Tilt

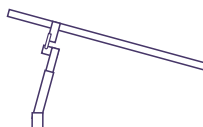

Corrugated



L-Feet



WIRING OVERVIEW

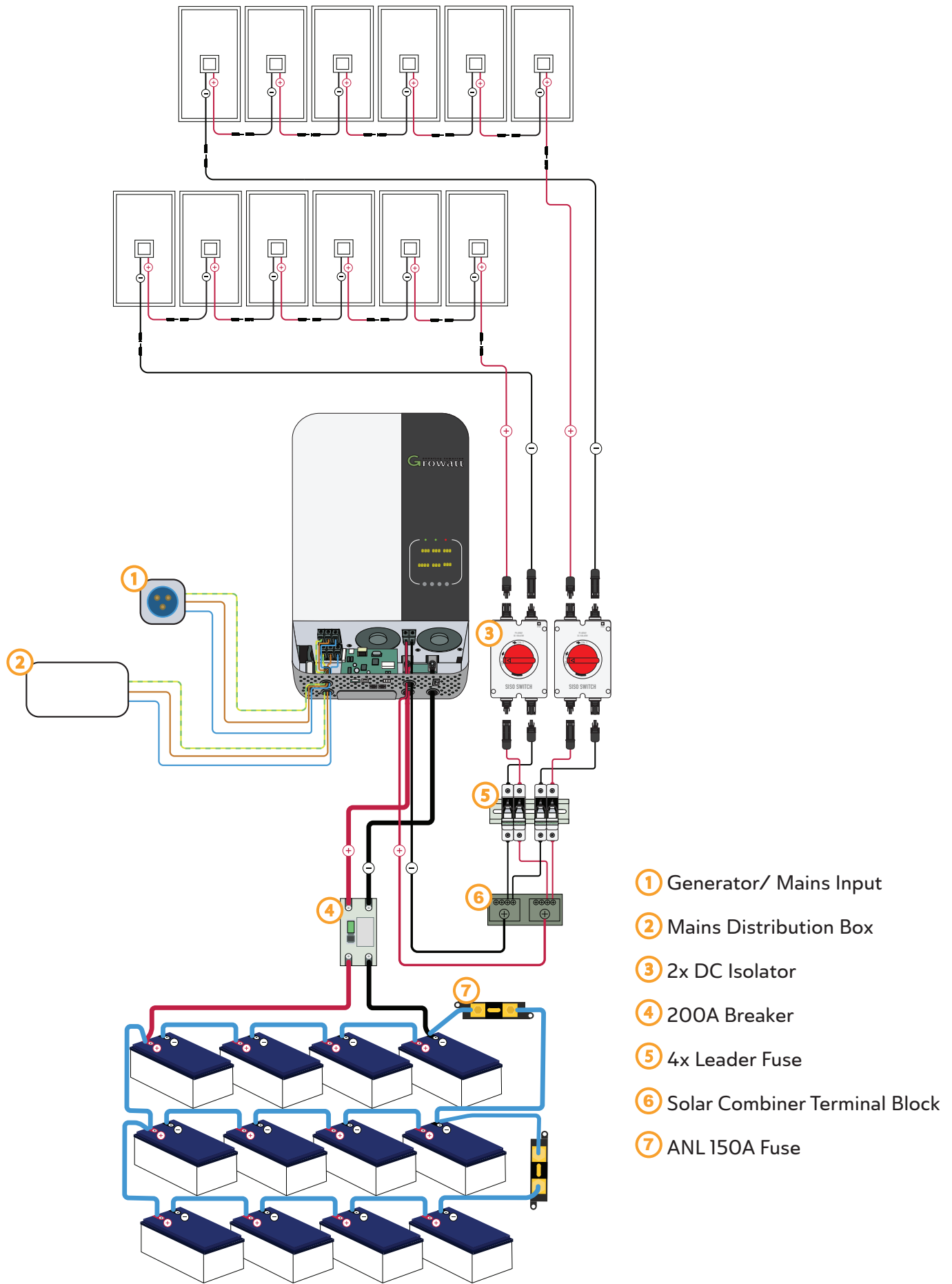

- ① Generator/ Mains Input
- ② Mains Distribution Box
- ③ 2x DC Isolator
- ④ 200A Breaker
- ⑤ 4x Leader Fuse
- ⑥ Solar Combiner Terminal Block
- ⑦ ANL 150A Fuse

SOLAR PANEL WIRING

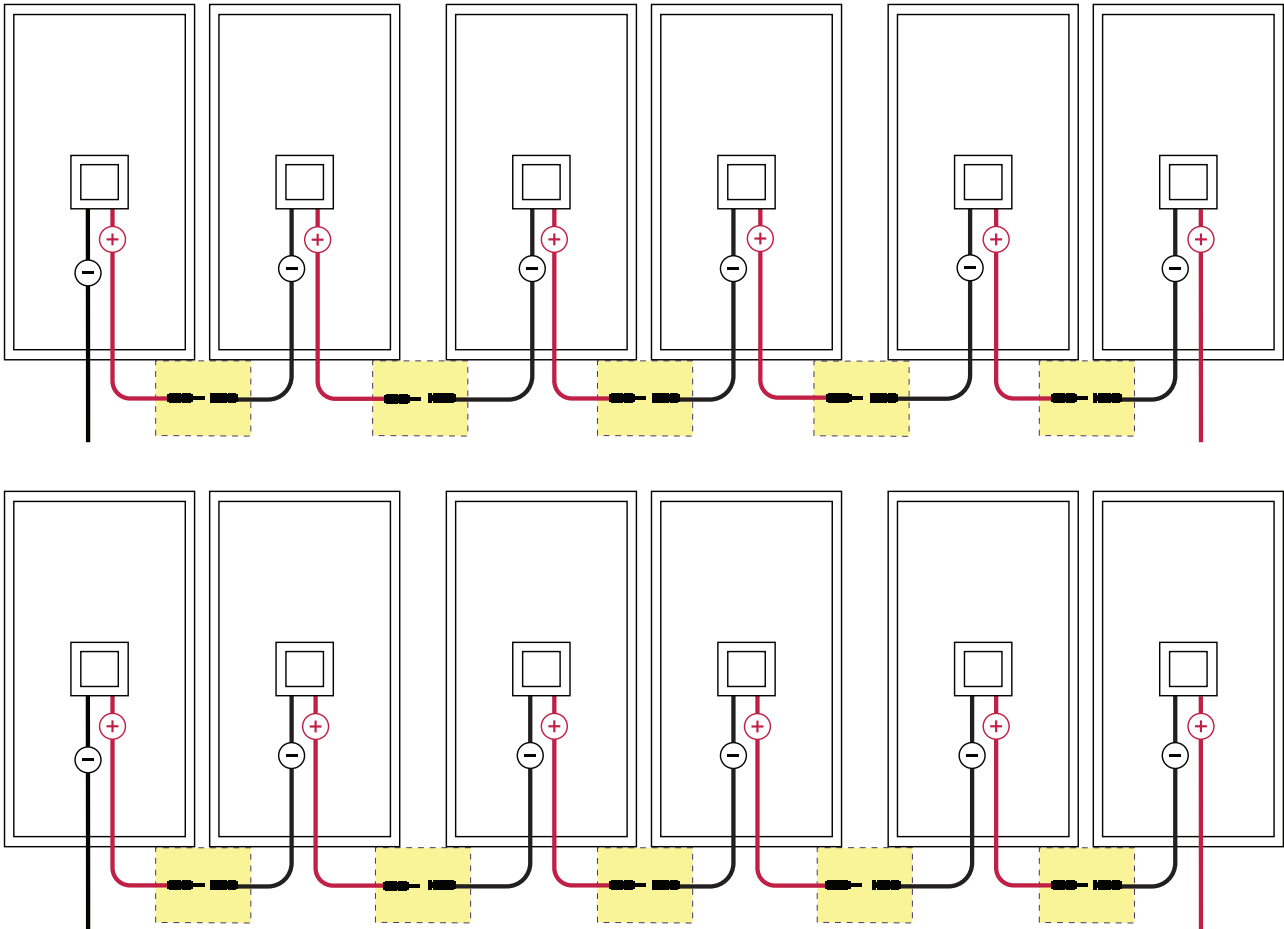
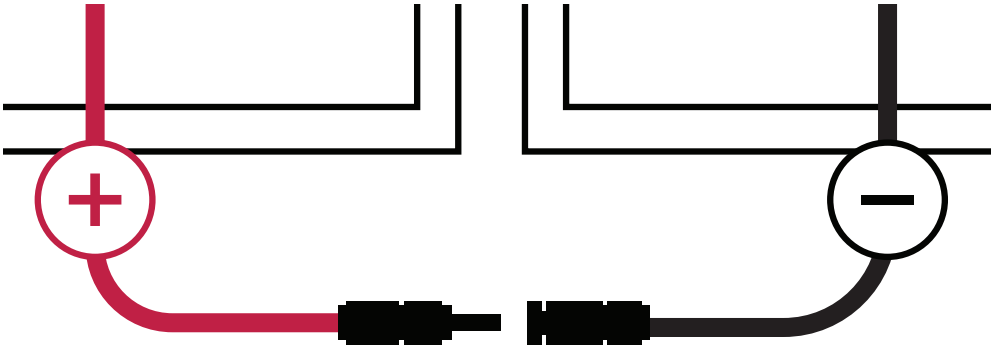

- 1 Start by creating two sets of six panels wired together. Connect the positive terminal of one panel to the negative terminal of the next panel.

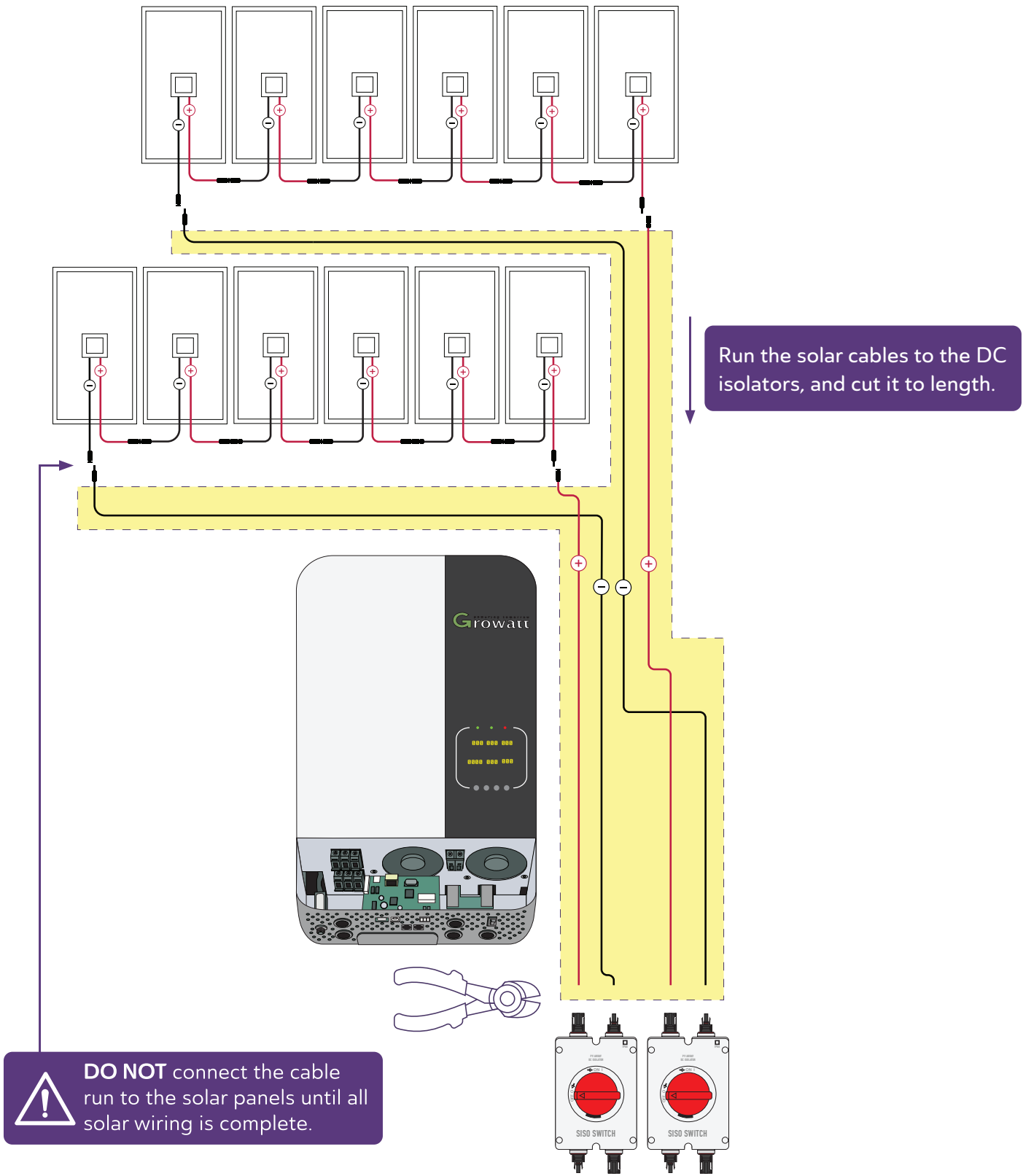

2 Run the 6mm² solar cables from the solar panels to the DC isolators, and cut it to length.

! **DO NOT** connect the cable run to the solar panels yet, as the cables will become live. Wait until all solar wiring is complete.

Note: We recommend the PV cable to be run inside of a conduit when the cable is run across a roof, floor, or the interior of a building.

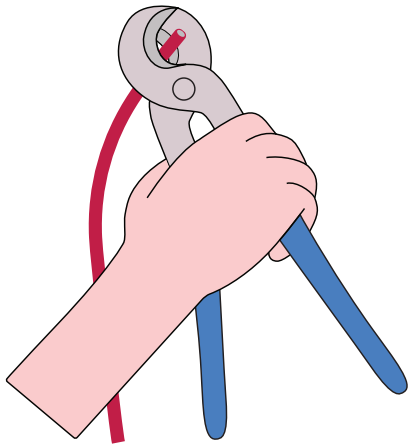

- 3 Use wire strippers to strip the ends off the black and red 6mm² solar cables. Strip the cables to approximately 7mm in length.

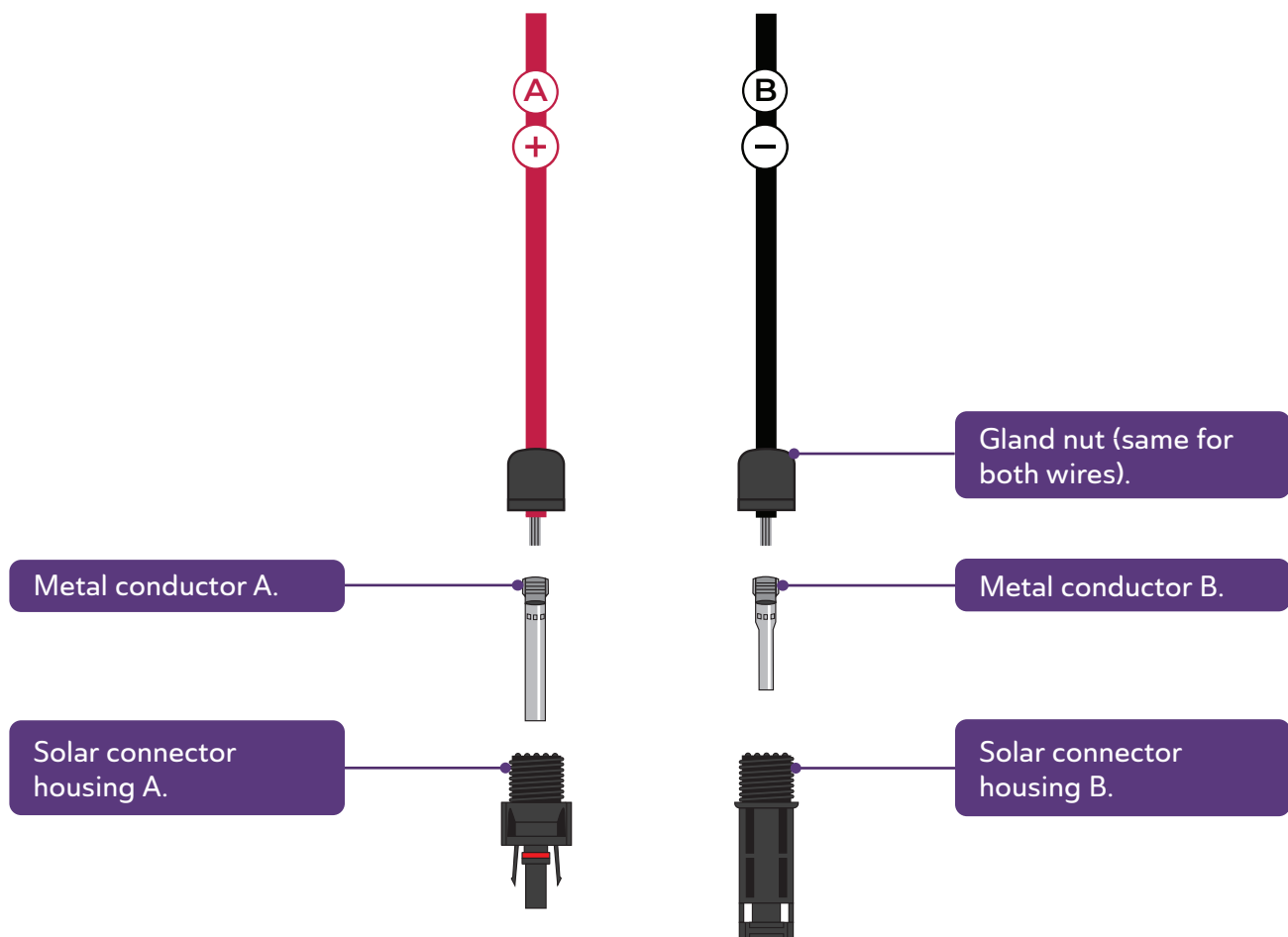

- 4 Ensure you use the correct metal crimp conductor, with the correct housing. Above demonstrates how each wire connects to its solar connector. The positive wire uses “Metal conductor A” and “Solar connector housing A”, the negative wire uses “Metal conductor B” and “Solar connector housing B”.

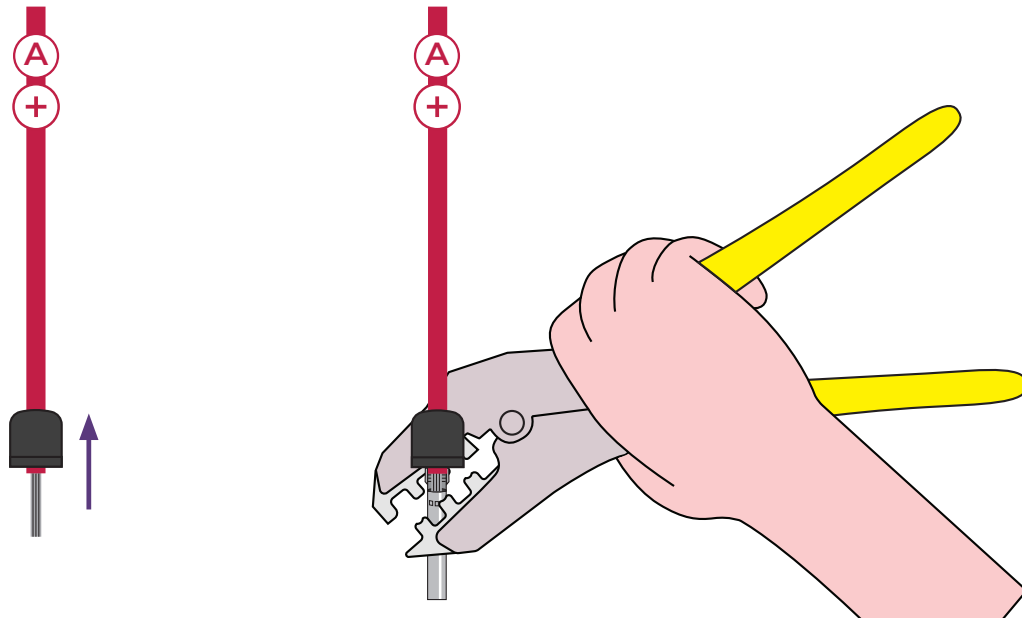

- 5 Starting with the red solar cable, place the silicon gland and gland nut onto the cable. Crimp “Metal Conductor A” onto the cable using the 4mm² crimping die.

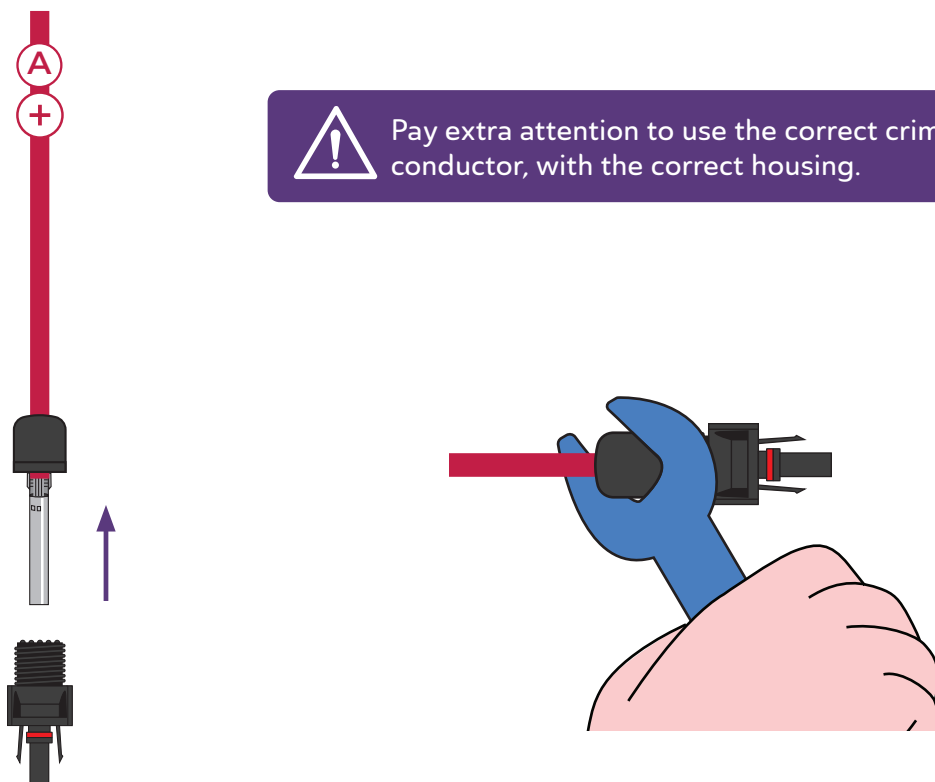

- 6 Insert the crimped “Metal conductor A” into the “Solar connector housing A” until it clicks, then tighten the gland nut using a spanner.

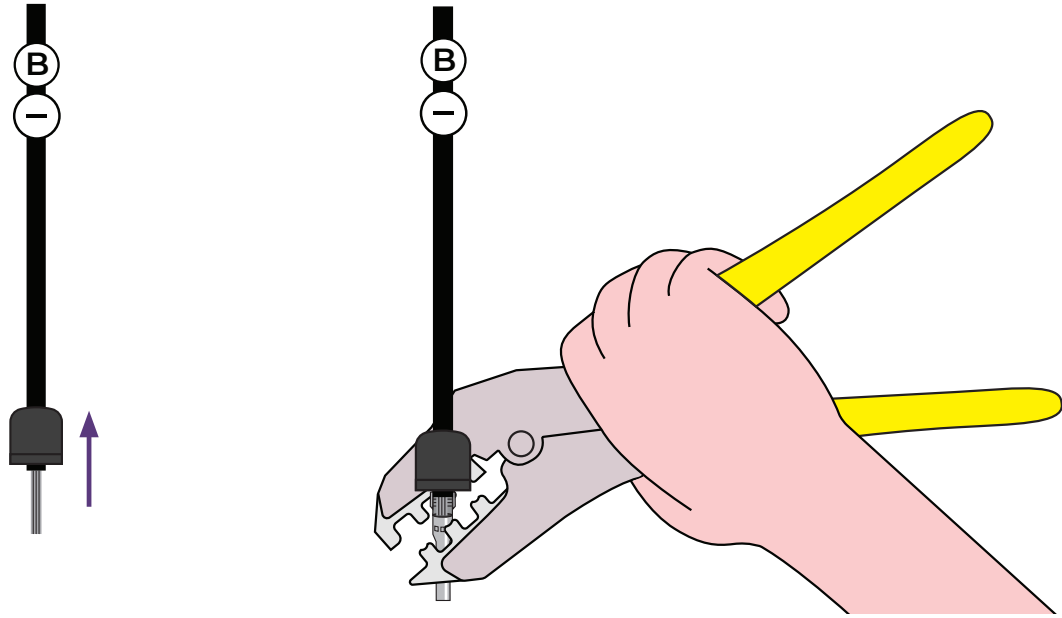

-
- 7** Move onto the black solar cable. Place the silicon gland and gland nut on to the cable. Crimp “Metal conductor B” onto the cable using the 4mm² crimping die.
-

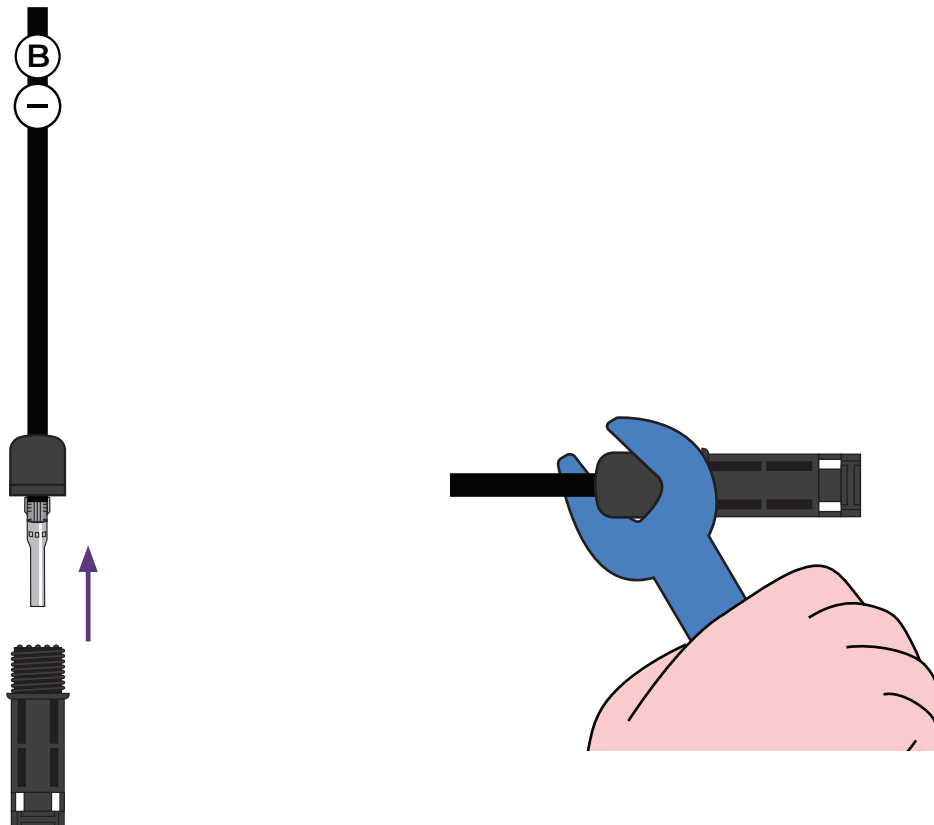

-
- 8** Insert the crimped “Metal conductor B” into the “Solar connector housing B” until it clicks, then tighten the gland nut using a spanner.
-

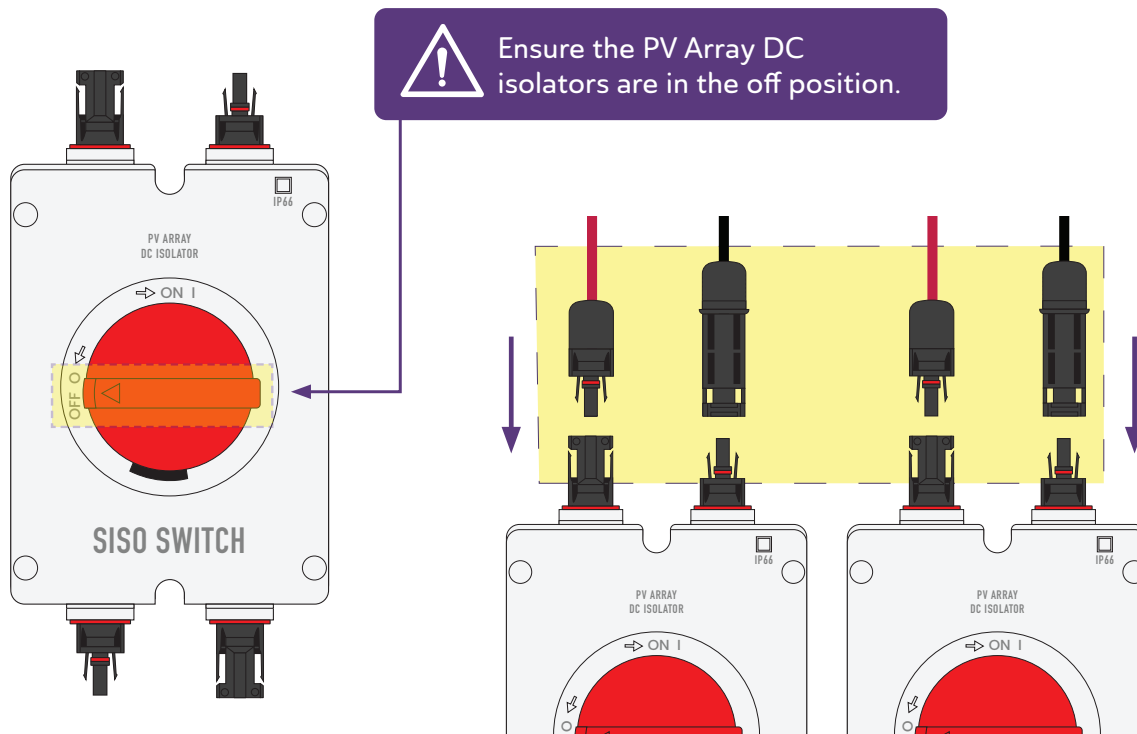

- 9 Ensure the PV Array DC isolators are in the off position. Then, connect the PV cable run from the solar panels. Ensure the other end of the cables stay disconnected from the solar panels.

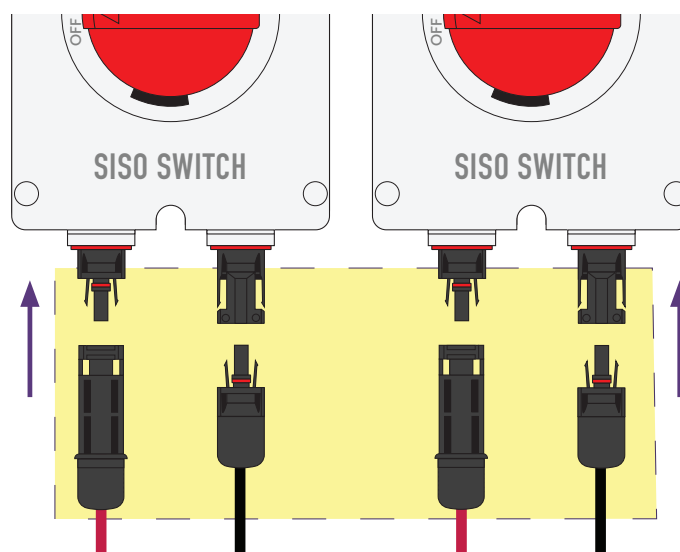

- 10 Repeat the process of crimping MC4 connectors onto a new set of cables (refer to page 9-11), which will connect the PV Array DC isolators to the PV Array fuses.

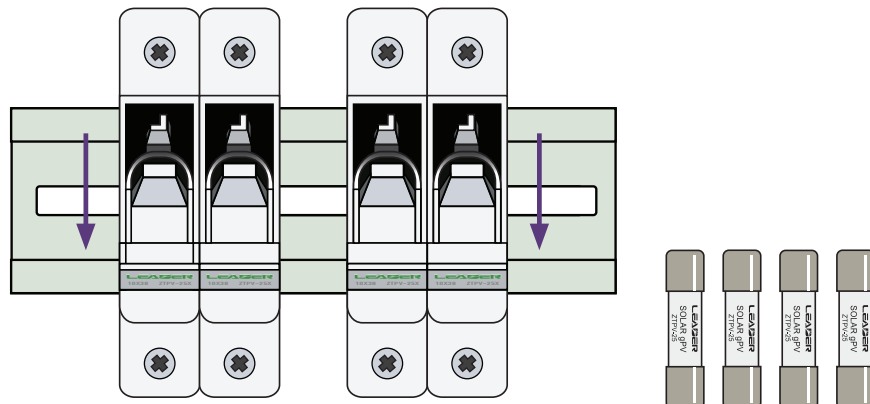

To disconnect the fuses, pull the front tabs down to open the fuse holders.

Keep the fuse holders open with the fuses left out of the fuse holders.



Ensure the solar cable run is **NOT** connected to the solar panels. Keep the fuse holders disconnected by keeping them open with the fuses **OUT** and the PV Array DC isolators are in the off position.

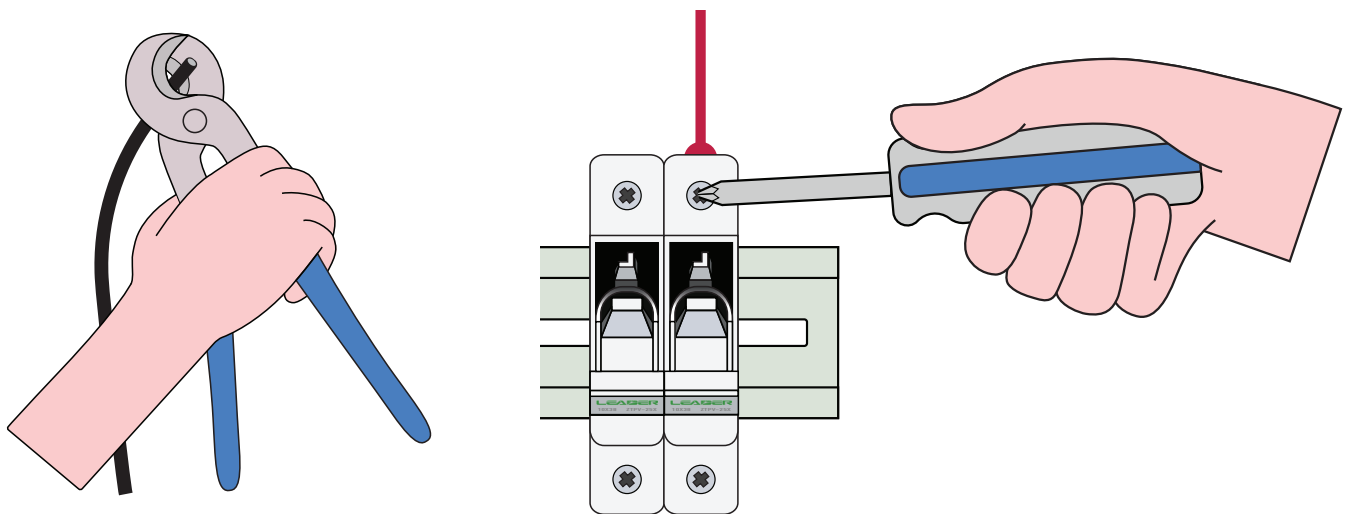

- 11 Ensure the fuse holders are disconnected by keeping them open with the fuses **OUT**. Use wire strippers to strip the ends of the solar cable, and terminate them in the fuse holders by inserting the stripped end and tightening the screw clockwise. Make sure the clamp inside the fuse holders are contacting the metal conductor, and **NOT** the insulation of the wire.

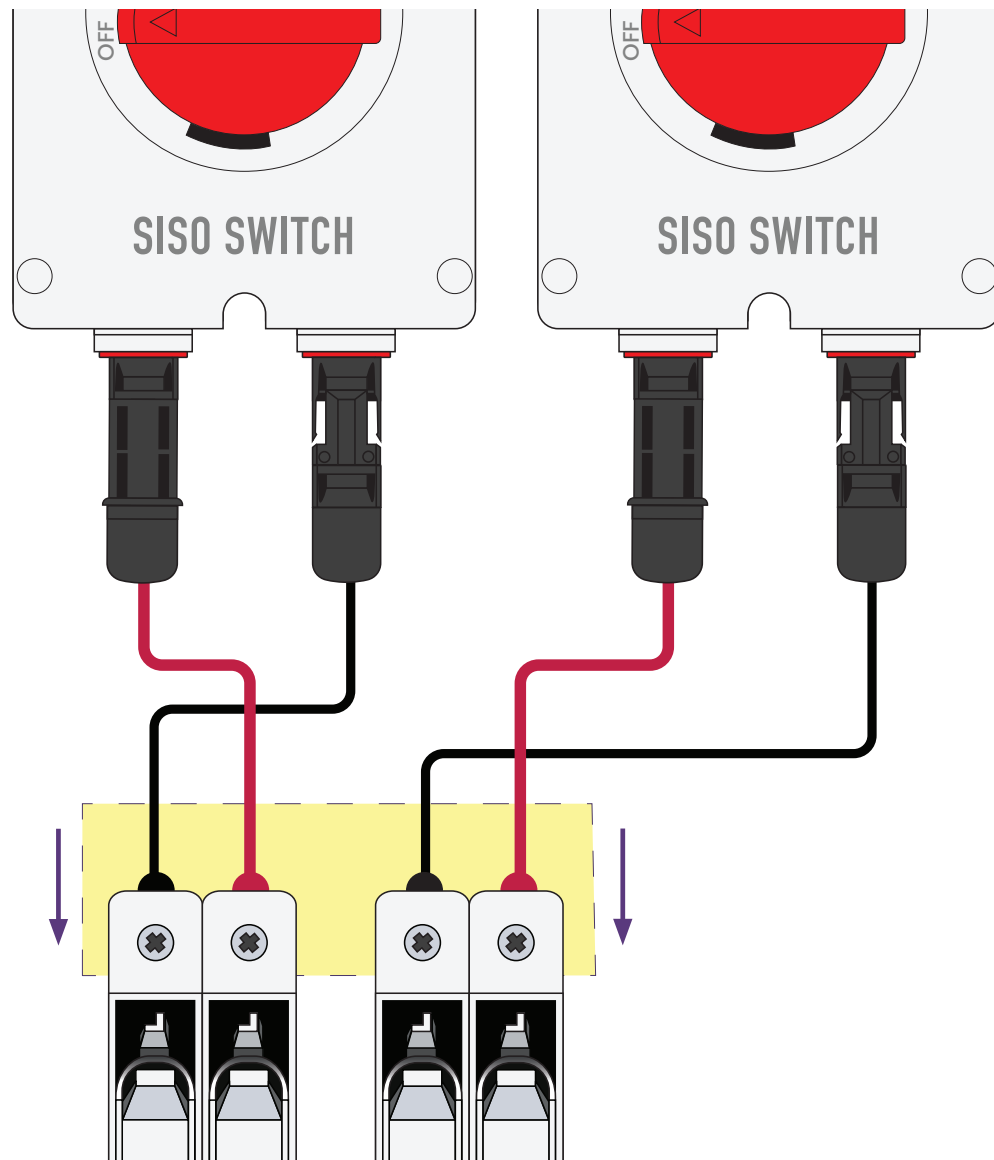

12 The PV Array DC isolators are now wired into the PV Array fuses.

CHARGE CONTROLLER & INVERTER WIRING

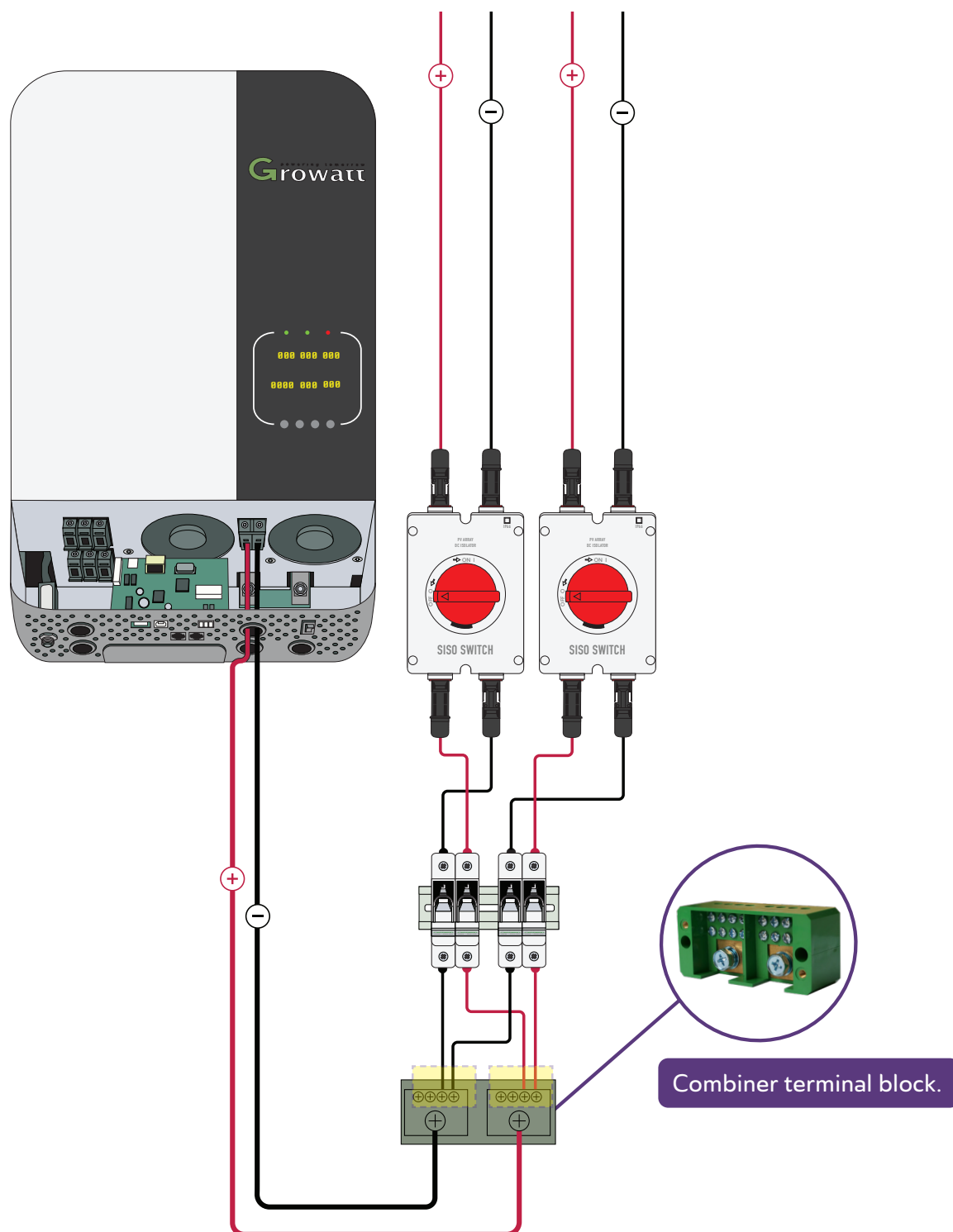

- 13 Use the green terminal combiner block to join both the negatives together in one side of the block, and both positives together in the other side. Then run the section of 16mm² cable from the M8 bolt terminals to the hybrid inverter.

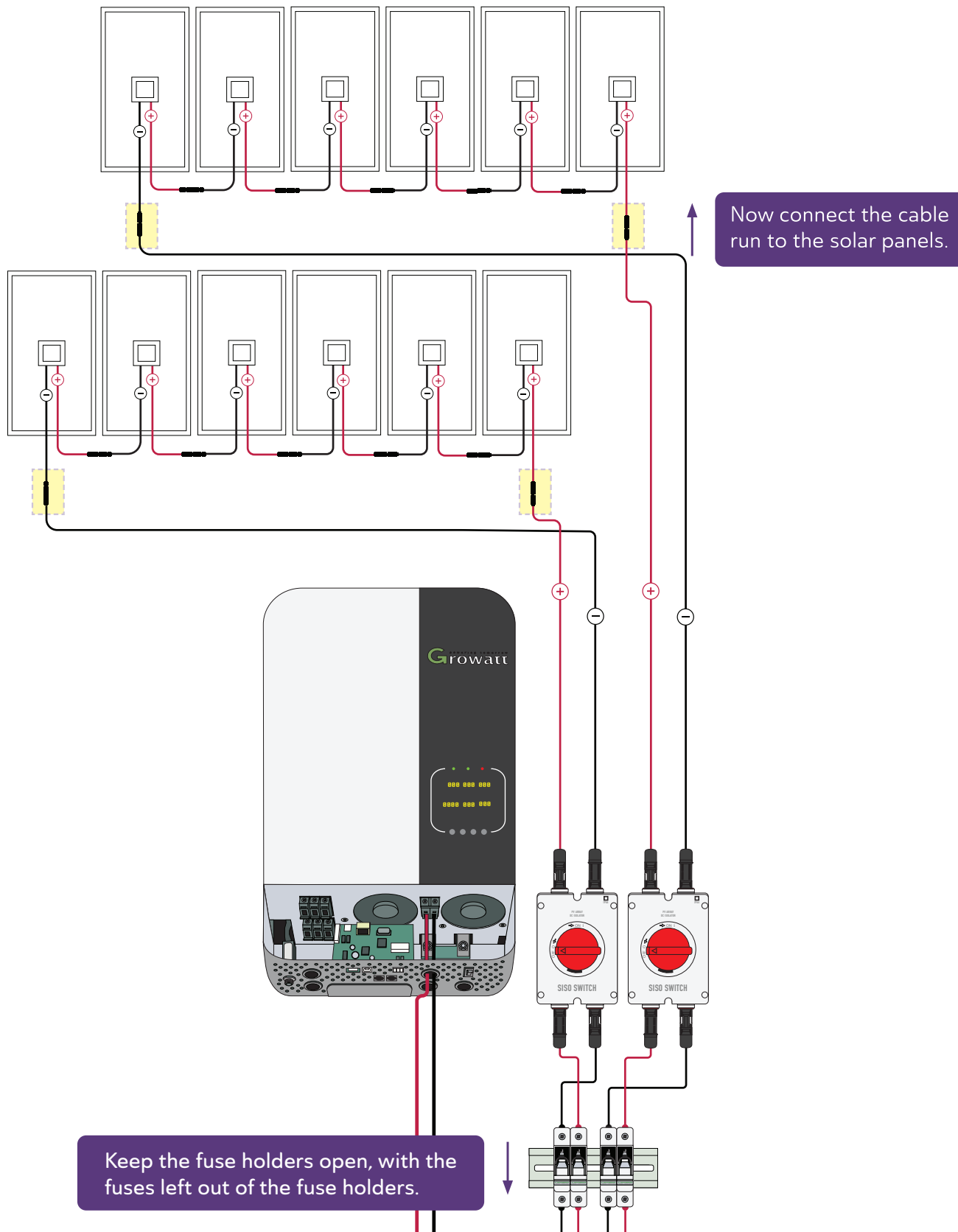

- 14 When the cables have been terminated in the fuse holders, with the fuses disconnected by keeping the fuse holders open with the fuses left out and the PV Array DC isolators switched "OFF", you can now connect the solar panels to the cable run. The fuses and DC isolators must be disconnected when connecting or disconnecting the solar panels from the cable run.

For your safety, do not connect or disconnect any solar cables when there is current running through them.

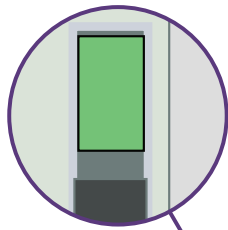

Ensure the 200A breaker is switched off, in the down position, showing a green indicator.

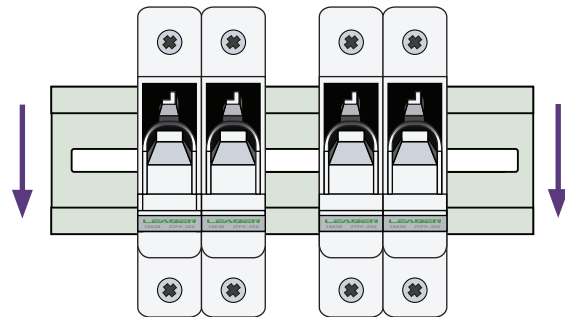
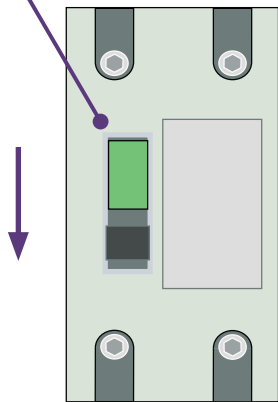

Keep the fuses disconnected by keeping the fuse holders open with the fuses left out.

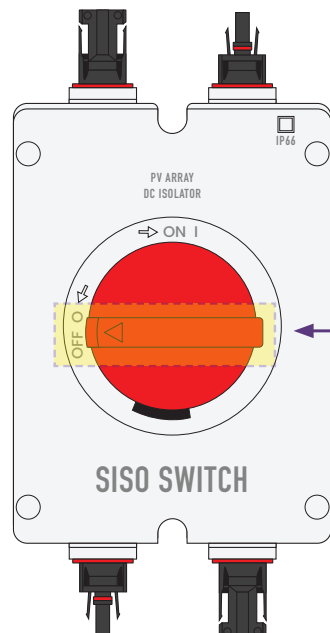

⚠ Ensure the PV Array DC isolators are in the off position.

- 15 Ensure the 200A MCCB circuit breaker is switched “OFF” (switch in the down position, indicator showing green). Keep the fuses disconnected by ensuring the fuse holders are open with the fuses left out and the PV Array DC isolator is switched to the “OFF” position, before wiring.

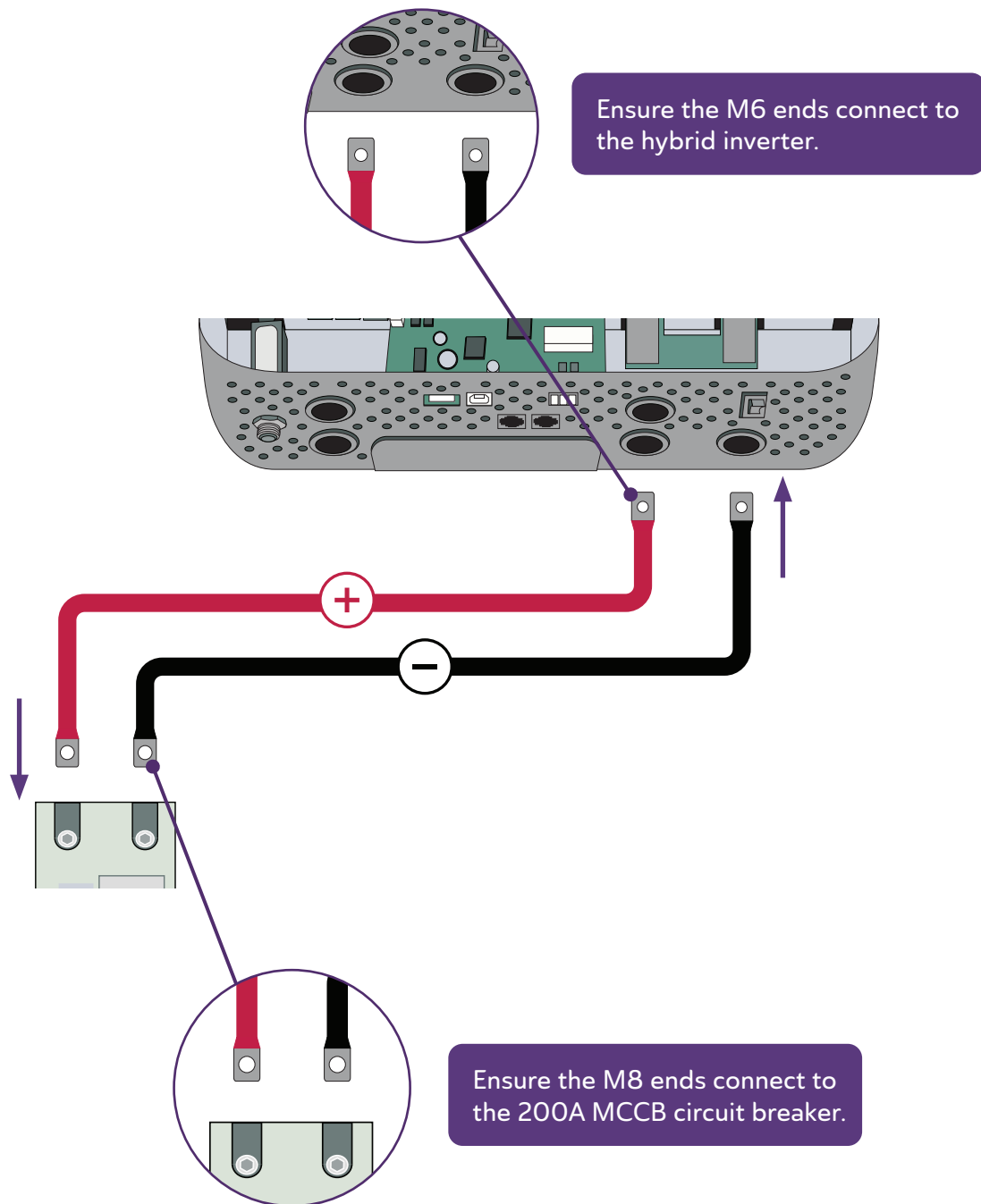

- 16** Before proceeding to connect the hybrid inverter to the 200A MCCB circuit breaker, align the 35mm² x 1m cables between the components to ensure that the M6 ends (smaller holes) are inserted into the hybrid inverter and the M8 ends (larger holes) are inserted into the circuit breaker.

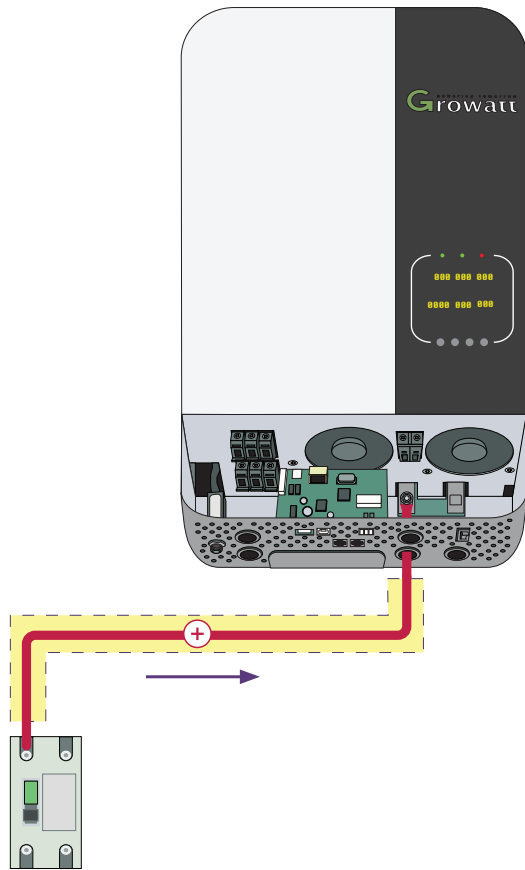

17 Wire the positive (+) 35mm² x 1m cable from the 200A MCCB circuit breaker to the hybrid inverter.

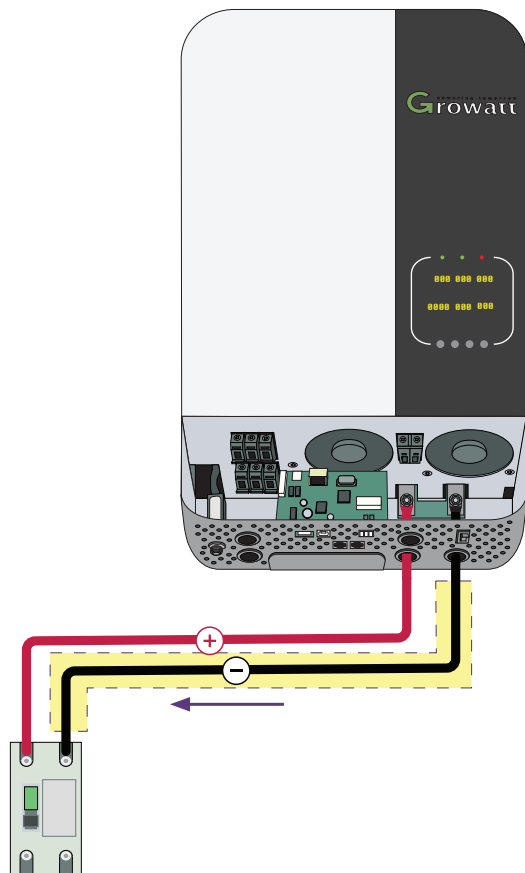

18 Wire the negative (-) 35mm² x 1m cable from the hybrid inverter to the 200A MCCB circuit breaker.

BATTERY BANK SETUP AND WIRING

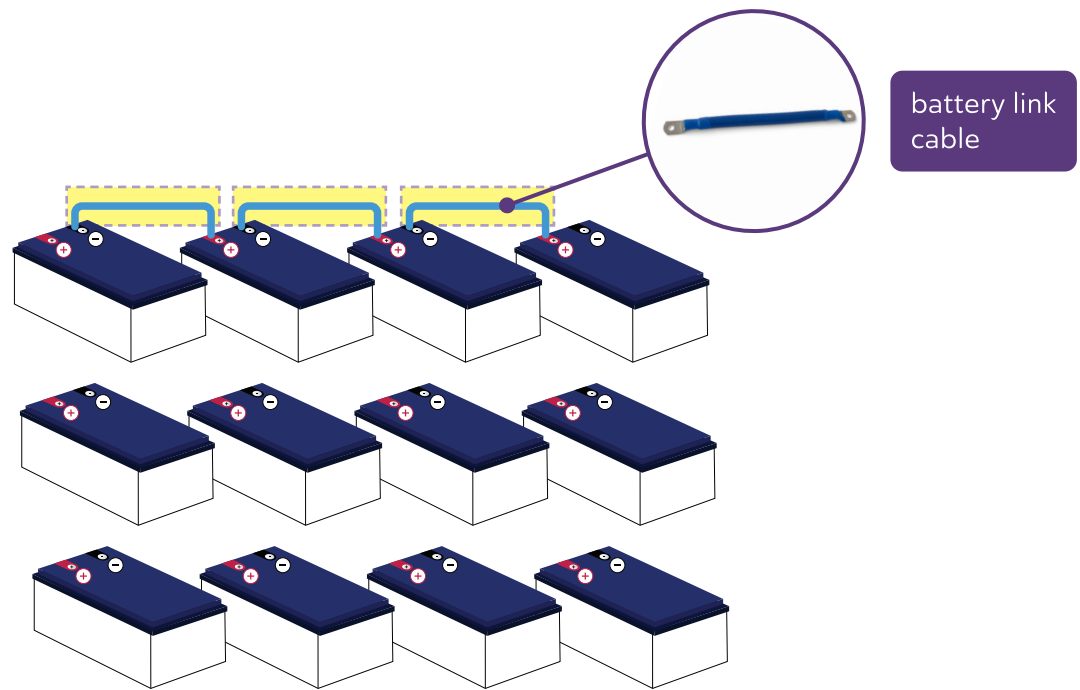

- 19 You will be wiring the battery bank with twelve 12V batteries, three parallel sets of four in series, to create a 48V battery bank. The large gauge cable is used to connect the batteries together and used to connect to the hybrid inverter.

Start by wiring the first row of four batteries together with the blue battery link cables.



When wiring the battery cables ensure that you fully attach each cable at both ends before moving onto the next.

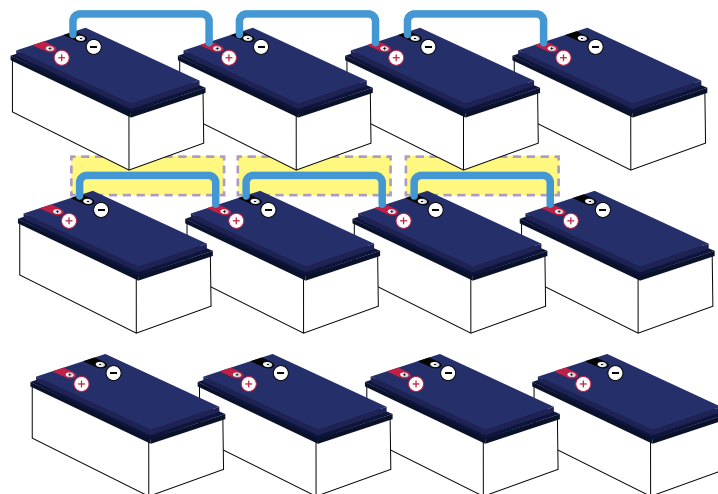

- 20 Next wire the second row of four batteries together.

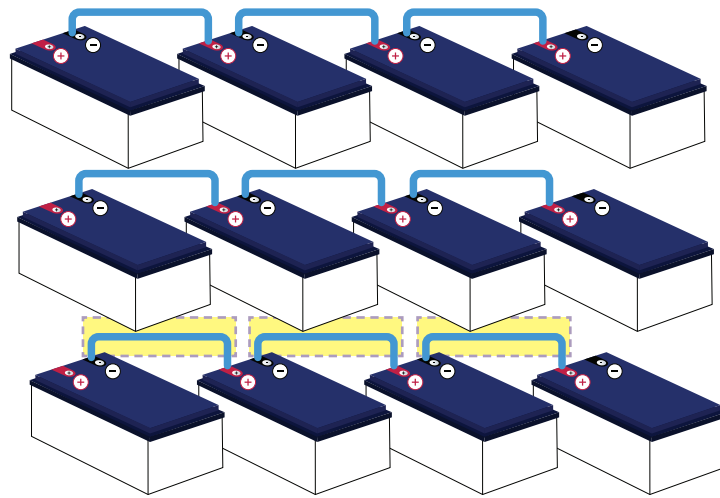

21 Then wire the third row of four batteries together.

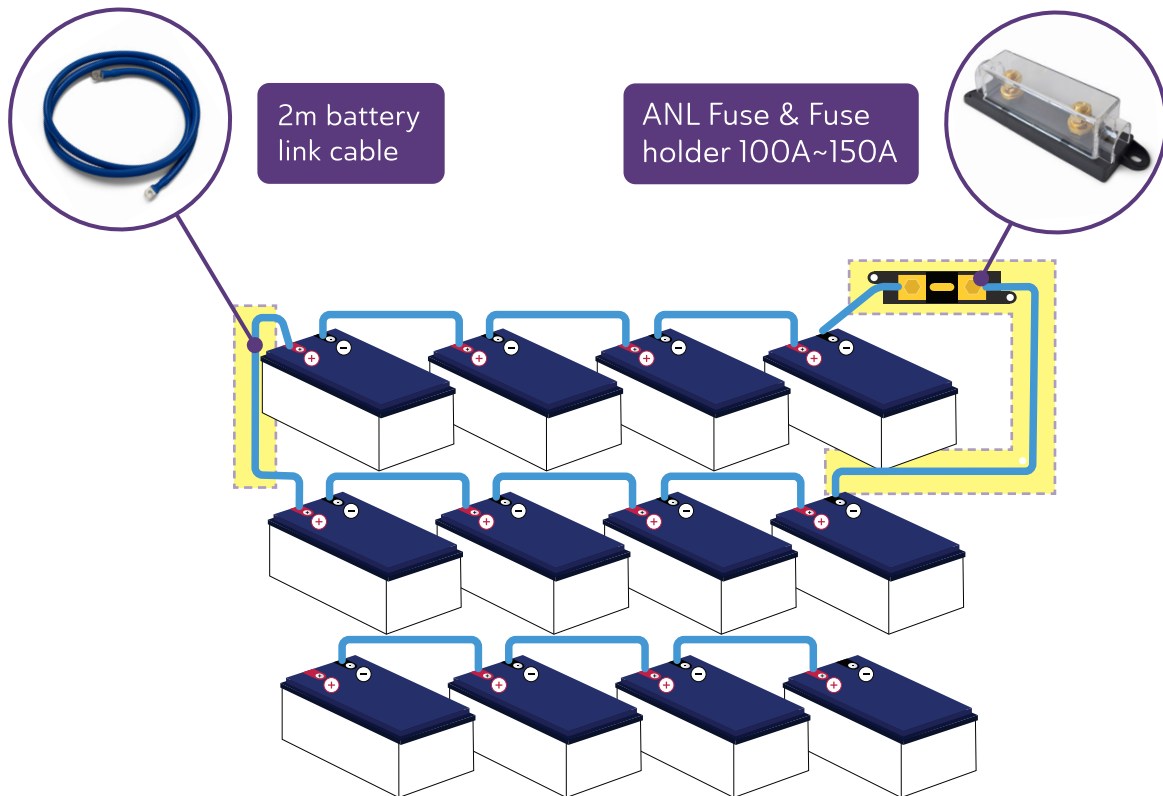

22 Wire a battery link from the negative of the first row of batteries to the ANL fuse and fuse holder. Then run one 2m battery link cable from the ANL fuse to the negative of the second row of batteries. Lastly wire the second 2m battery link cable from the positive battery of the first row to the positive battery of the second row.

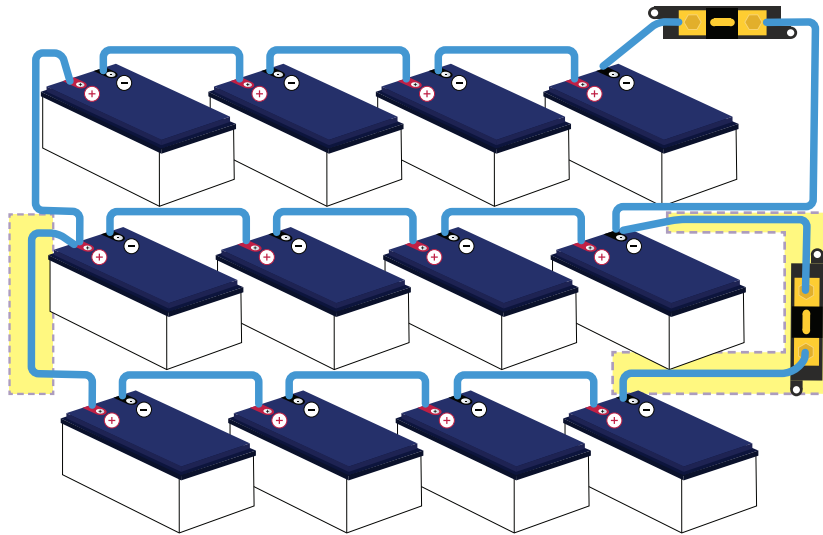

- 23 Next wire a battery link from the negative of the second row of batteries to the ANL fuse and fuse holder. Then run one 2m battery link cable from the ANL fuse to the negative of the third row of batteries. Lastly wire the second 2m battery link cable from the positive battery of the second row to the positive battery of the third row.

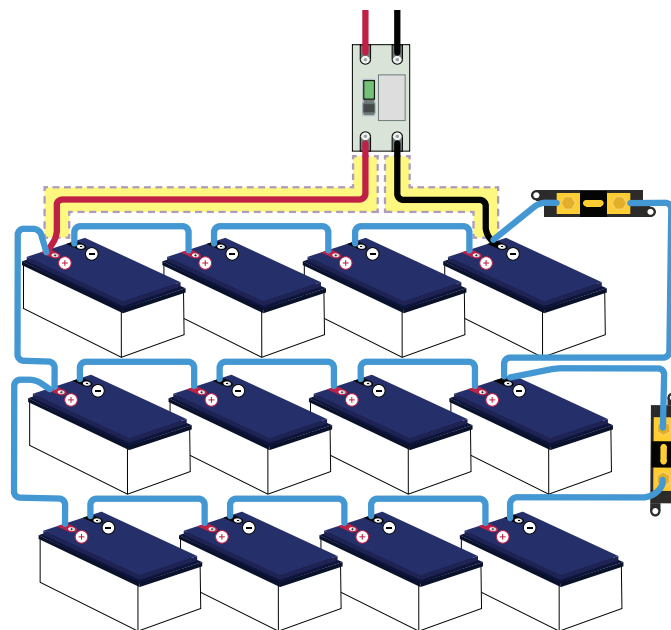

- 24 Wire one set of red and black 35mm cable to the hybrid inverter through the 200A MCCB circuit breaker.



When running the wires from the battery bank to the circuit breaker, be very careful not to touch the positive (+) to the negative (-). This will cause a short circuit, which will result in a spark, and may damage the batteries or the cables.

We recommend only running one cable at a time (positives first, then negatives) to minimise risk.

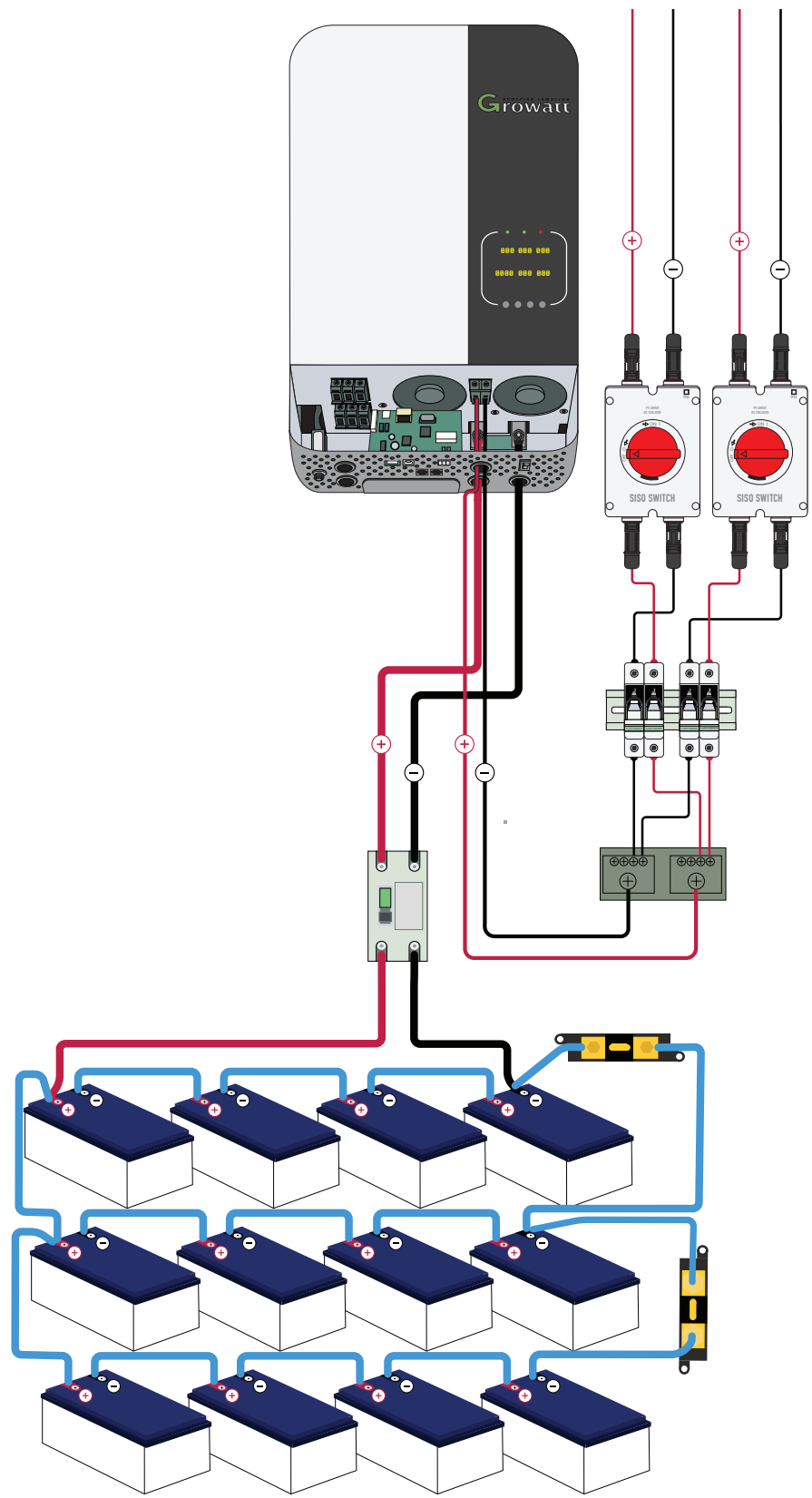

25 Once you've wired the batteries into the hybrid inverter, this is how the completed wiring should look (excluding the panels). Double check everything is wired correctly and tightened before proceeding, to prevent damage to your system. For this manual, all steps should be done by an electrician.

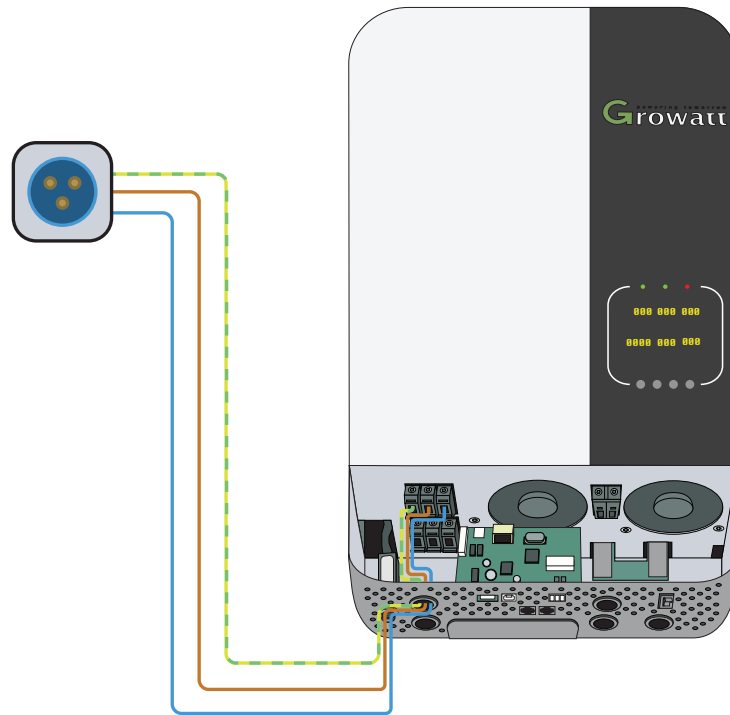

26 If using the utility / generator input, use AC cable rated for 40A. If using a plug, use a 32A rated plug.

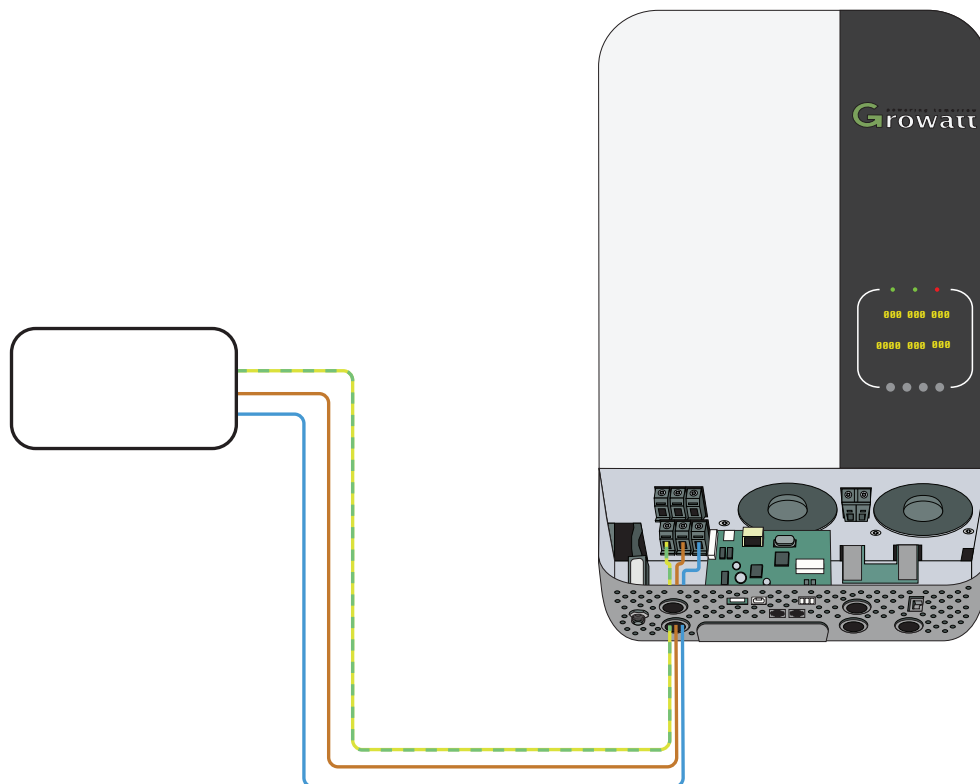

27 **The hybrid inverter does not have an earth to neutral connection.** This connection can be made at the main distribution board, unless the system is being used with a generator that also has an earth neutral connection.

START UP PROCEDURE

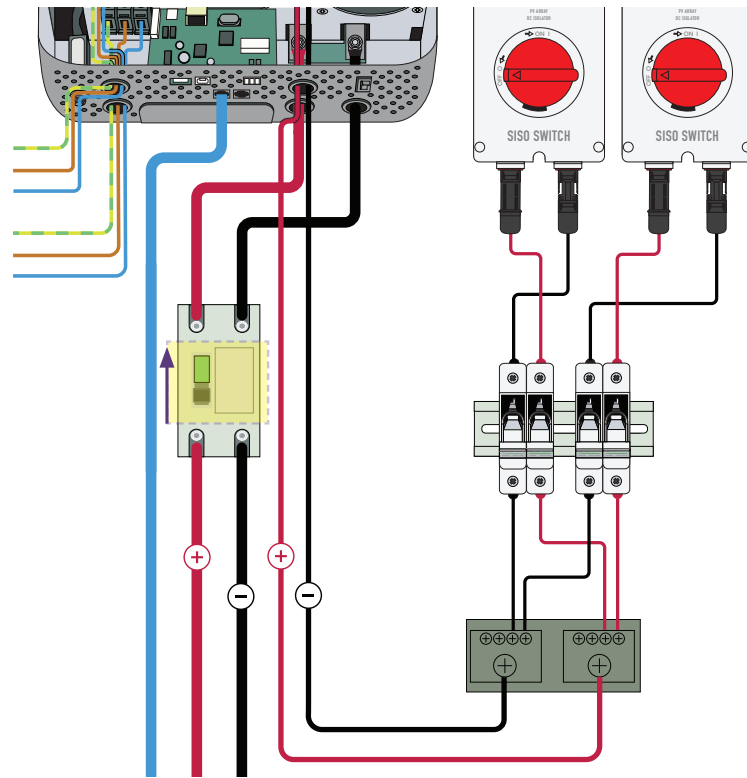

- 28 Switch on the circuit breaker and fuses in the following order. First, switch on the battery to hybrid inverter 200A MCCB circuit breaker.

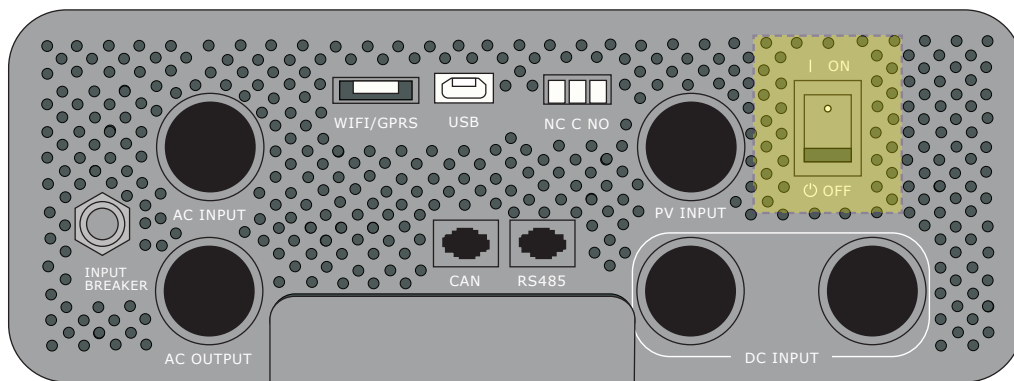

- 29 Next, flick the "ON" switch located on the bottom of the hybrid inverter and wait for the hybrid inverter to power on. Refer to page 12 of the hybrid inverter manual to ensure normal operation.



30 Configuring your Hybrid Inverter

Manual Start Generator Parameters:

When using these settings, whenever generator power is available the hybrid inverter will use the power supplied to charge the batteries and supplement power usage.

Hold 'Enter' for 3 seconds.

Use the up and down arrows to navigate to the different setting parameters.

Use the following setting parameters:

Setting Number	Setting Description	Recommended Value
1	Power Priority	UTL (Utility)
5	Battery Configuration	USE (User)
21	Low Voltage Disconnect	48V

Auto-Start Generator Parameters:

When using these settings, the hybrid inverter will only draw power from the generator when the battery voltage is below the value set in setting 12.

When the battery voltage is below setting 12 the dry contact will close, which can be used as a signal to start the generator.

The dry contact will open again when the battery voltage is above setting 13 or the batteries reach the float charging stage.

Setting 21 < Setting 12 < Setting 13

Setting Number	Setting Description	Recommended Value
1	Power Priority	SBU (Solar before Utility)
5	Battery Configuration	USE (User)
12	Generator Start	48.5V
13	Generator Stop	56V
21	Low Voltage Disconnect	47.5V

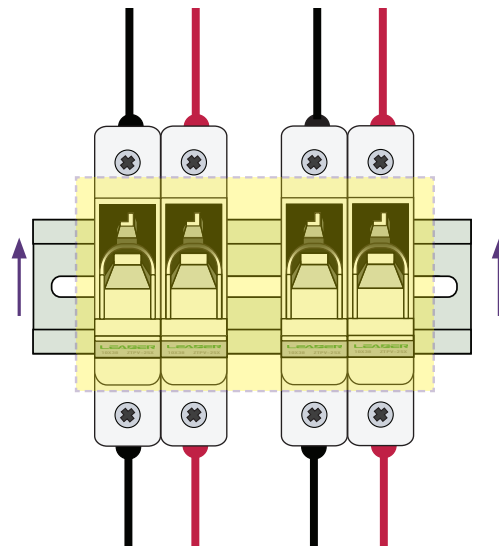

-
- 31 Then, connect the panels to the hybrid inverter by inserting the fuses into the fuse holder and closing the fuse holders.
-

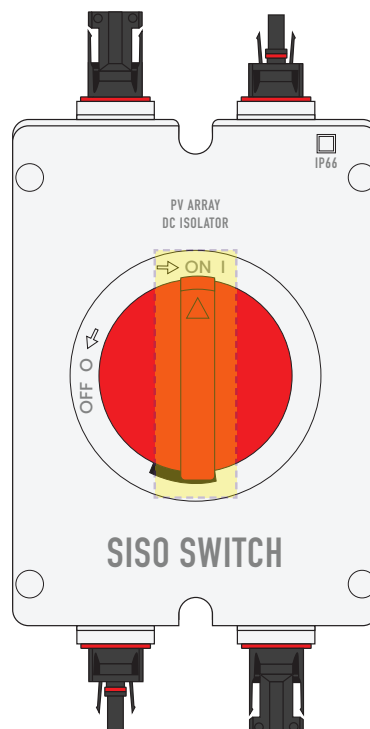

-
- 32 Lastly, switch the PV Array DC isolators to the "ON" position.
-

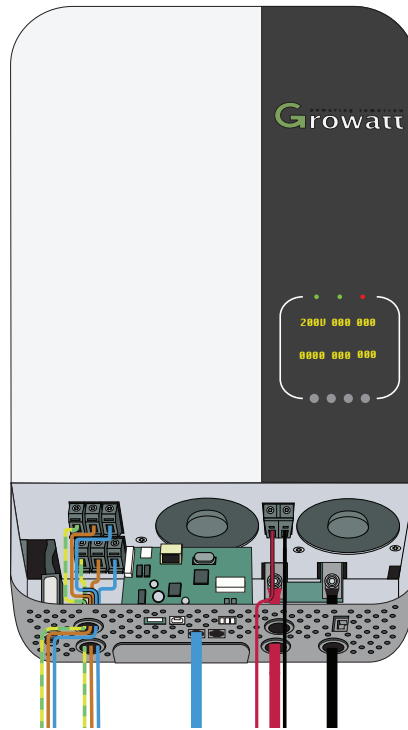

-
- 33** The Green LED on the PV Charge should flash, and the panel voltage should be around 200V-300V in full sunlight.
-

TROUBLESHOOTING GUIDE

We've compiled this list of common problems our customers may encounter with their solar gear to help you solve any issues as fast as possible.

If you don't find the answers you need here, or your issue continues after implementing the given solution, please get in touch.

1. My solar panels are not putting out as much power as normal

Once you've determined the drop in power is not due to weather changes, check your panels for any shade or shadows.

Check both morning and afternoon in case the shadows are inconsistent. Make sure they're cleaned off, as things such as thick dust or bird droppings can affect your output. Finally, double check all your connections are clean and secure.

If none of these issues are causing your power drop, you'll need to send us some clear pictures of your hybrid inverter readings.

We need to see the battery voltage, solar panel voltage, and solar panel amps. Please send readings from the middle of the day with peak sun, as well as the end of the day or early morning.

2. My hybrid inverter keeps shutting off

Check your battery voltage, as hybrid inverters have an auto shut-off feature to protect them from damage when the voltage drops too low. The manual that came with your hybrid inverter will have this information, as well as a full troubleshooting guide.

3. My batteries aren't charging

It's likely that your batteries have been drawn very low, and are not able to charge fully if you continue to draw power. Check all the wiring is secure and undamaged, then turn off the breaker between the batteries and the hybrid inverter, leaving the others on, and let the batteries charge back up to full.

If you don't believe you have knowingly used enough power to drain the batteries, check all your appliances to see if something is using more power than it should.

4. My batteries drain very fast when the sun goes down

The hybrid inverter may read 100% while charging at the higher voltage, but then it will quickly drop down lower when there is no charge applied. This could be because the batteries charge at a higher voltage, so when the sun goes down the battery voltage will stabilize at a lower level.

It may also mean the batteries have been drained low, and they are not getting enough charge to be fully charged by the end of the day.

Try reducing your power usage for a few days to make sure the batteries are getting fully charged, but also make sure to check the solar panels are not being shaded during the day, or there is an appliance that has been left on. When customers notice less solar output the most common cause is shading - as we transition between winter and summer the sun's path changes, which can cast new shadows across the panels which weren't noticed when you first installed the system.

5. My hybrid inverter beeped, and the PV charge indicator was blinking

You may hear your hybrid inverter beep, and see an orange light blinking if you check quickly. This occurs when the battery voltage is too high. This can happen very occasionally when the hybrid inverter is charging the batteries completely.

It can happen when you have a very sunny day, and use a high draw appliance like a toaster - when the toaster stops the solar then works very quickly to top off the batteries, and can peak the voltage briefly. As it's a hybrid inverter, it is working to protect itself and your batteries, so it can sometimes be a little bit on the over protective side.

6. My hybrid inverter fan turns on all the time

You may notice the fan turning on even when you're not using a high load appliance. The hybrid inverter can sometimes be a little overprotective of itself, especially on warm days, and the fan will turn on when it doesn't seem necessary. Make sure there is sufficient airflow around your hybrid inverter and you should be fine.

CONTACT US

Our website: gridfree.store

Email us: info@gridfree.store

Message us on Facebook: [@GridFree.Store](https://www.facebook.com/GridFree.Store)

Give us a call: (09) 218 5533

Address: By Appointment– C4/27 Smales Road, East Tāmaki, Auckland, 2013

Hours: 9am-5pm, Monday-Friday

Kit viewings, demos, and pick ups at Auckland warehouse by appointment only.
Please give us a call and we'll be happy to set up a time to meet you.



GRIDFREE