

# LIFESTYLE KIT

INSTALLATION MAUNAL  
HYBRID LITHIUM



GRIDFREE

# WARNING - READ CAREFULLY

---

While this manual seeks to be as comprehensive as possible, some aspects are not covered due to the different requirements for each installation. We recommend consulting the applicable standards for all installations. These may include:

- AS/NZ 3000
- AS/NZ 4509
- AS/NZ 5033
- AS/NZ 5139

Any installation aspect involving voltages above ELV (120VDC) or groundworks is prescribed electrical work and must be carried out by an accredited electrician.



## **Risk of Electrical Shock, Burning and Explosion**

- Improper installation or failure to follow proper work-site practices can place the installer and user at risk of multiple hazards.
- The installation contains works with multiple voltages that can cause electrical shock.
- Improper installation can cause excessive electrical currents, which may lead to burning.
- Lead-acid batteries can also release hydrogen gas when they are charged, which can create a fire or explosion hazard if it accumulates in an enclosed space.



## **Risk of Chemical Burn and Poisoning from Battery Electrolyte**

- Lead acid batteries contain sulfuric acid, which can cause burns and other injuries if it comes into contact with skin or eyes.
- Risk of respiratory problems from inhaling battery acid fumes.
- Do not open or modify the battery.
- Use correct personal protection equipment, such as rubber gloves, boots and goggles, when handling and installing batteries.



## **Risk of Injury due to Short Circuit Currents**

If a battery bank's output is short-circuited, injury due to heat or eye injury due to arc flash may occur.

When working with the battery bank:

- Connect one wire at a time.
- Use battery caps.
- Use insulated tools.
- Do not wear any conductive items.
- Do not place any tools on the batteries.



## **Risk of Injury due to the Handling of Heavy Objects**

- Components in the installation, such as batteries, are very heavy.
- Get help from a partner or team to lift and move heavy objects.
- Use proper lifting techniques and equipment such as dollies, carts and forklifts.
- Improper handling may lead to back injuries, strains or sprains, slips, trips or falls.

# LIFESTYLE HYBRID LITHIUM

---



Installation of this kit legally requires an electrician.

We are always happy to help guide you through the install, troubleshoot, and answer any questions. You can contact us on [09 218 5533](tel:092185533), or [info@gridfree.store](mailto:info@gridfree.store).

**We recommend reading these instructions in full prior to starting your install.**

---

# KIT CONTENTS

---

12x PERC MONO Solar Panel



1x Growatt ARK Battery Base



6x Growatt ARK LiFePO4 2.56kWh Battery

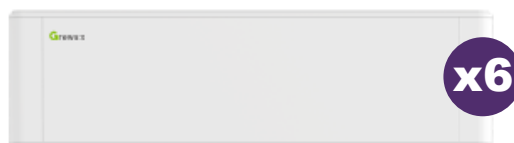

1x Growatt 5KW Hybrid Inverter SPF 5000ES



---

4x Leader Fuse and Fuse Holder



x4

1x 200A Hybrid Inverter DC MCCB

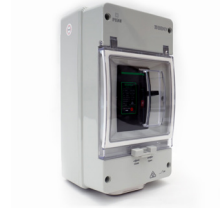

1x PV Combiner MCB Enclosure



2x PV DC Isolator Switch



---

1x Growatt ARK Battery Cable Set



1x 35mm<sup>2</sup> Cable 1m Pre-Crimped M6 + M8 (Red + Black)



2x 6mm<sup>2</sup> Solar PV Cable Pair 10m – Pre-Crimped MC4 (Red + Black)



1x 10mm<sup>2</sup> Solar PV Combiner to Inverter Pre-Crimped (Red + Black)



1x MC4 Crimp Tool Set



1x Pack of Safety Stickers



# REQUIRED TOOLS

---

Screwdrivers



Drill



Wire Strippers

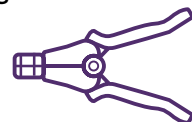

Wire Cutters



6mm Allen Key



MC4 Crimping Set



# SOLAR MOUNT OPTIONS

---

Ground



Tilt

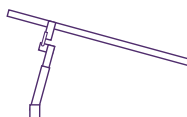

Corrugated



L-Feet



# WIRING OVERVIEW

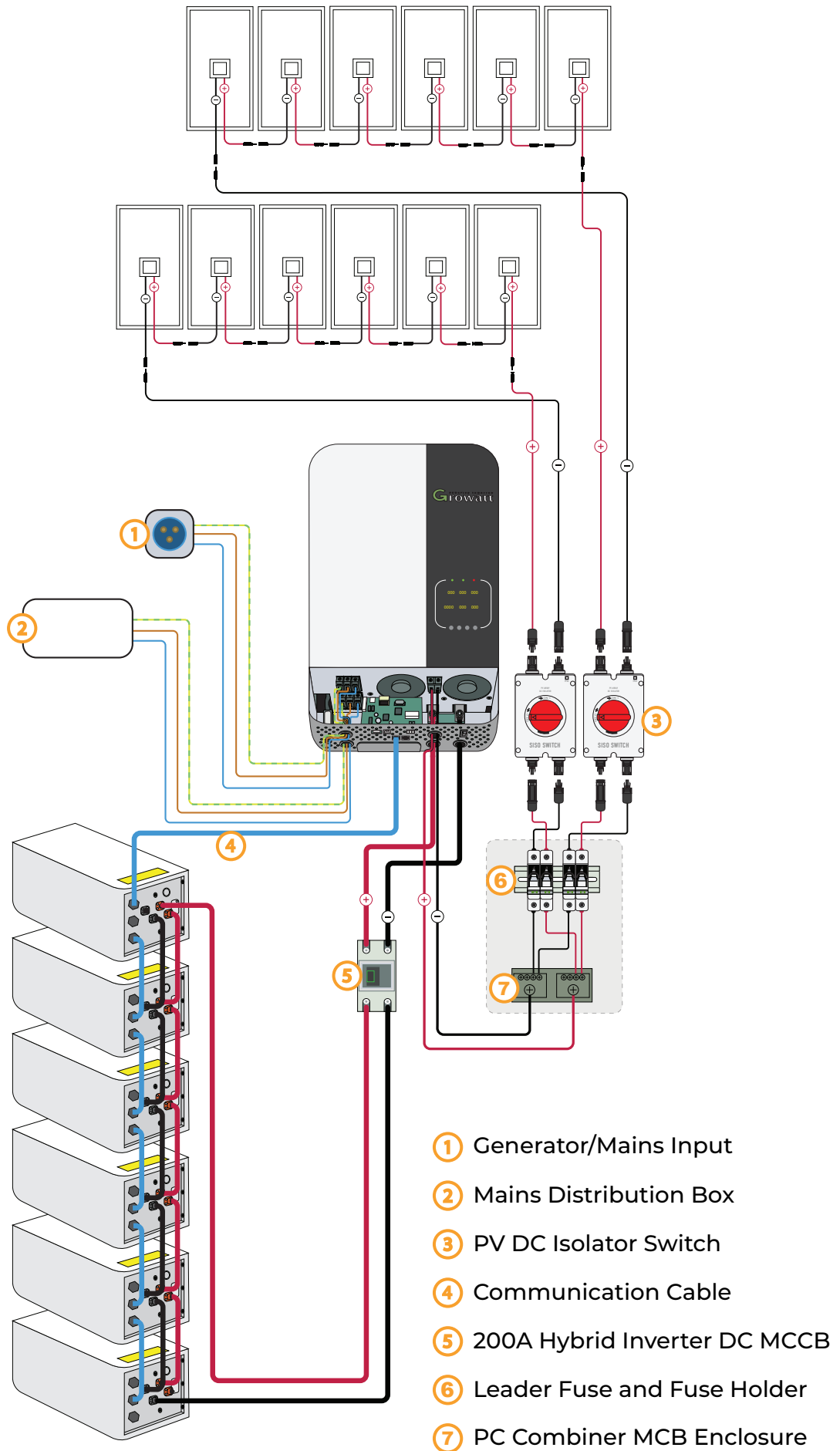

# SOLAR PANEL WIRING

---

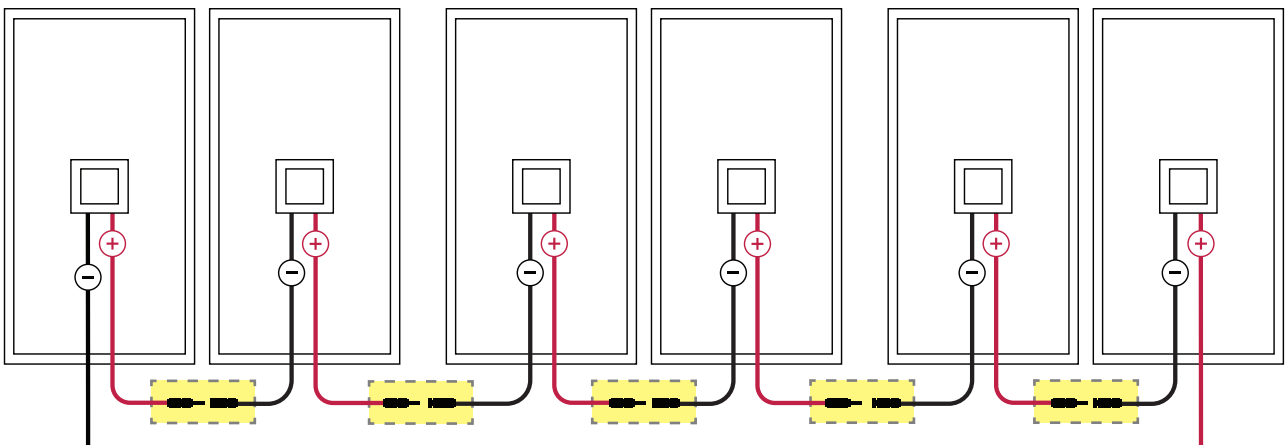
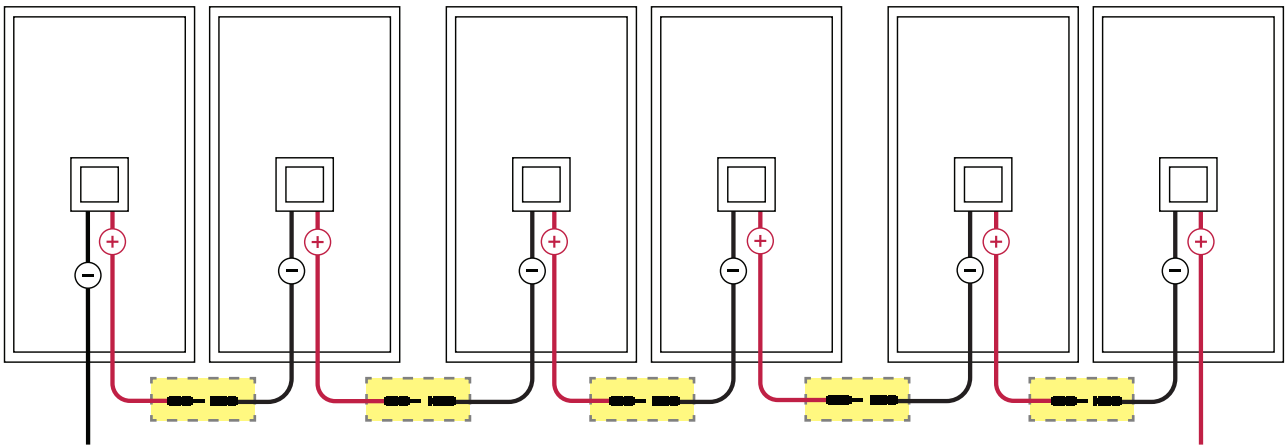
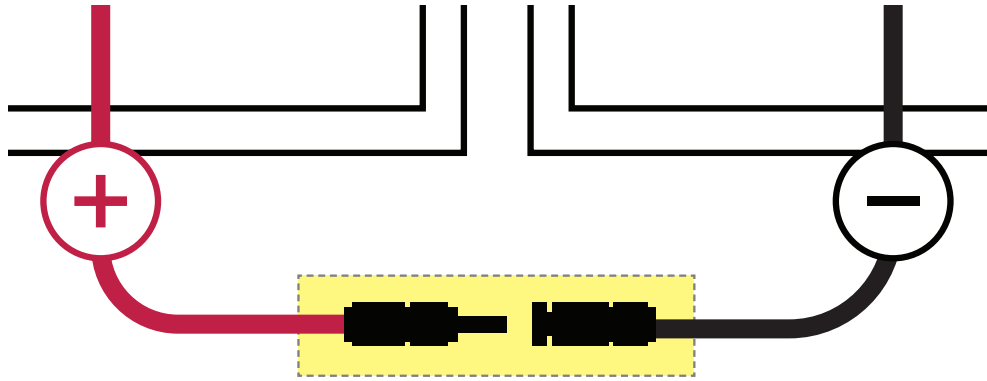

- 1 Start by creating two sets of six panels wired together in series. Connect the positive terminal of one panel to the negative terminal of the next panel.
-



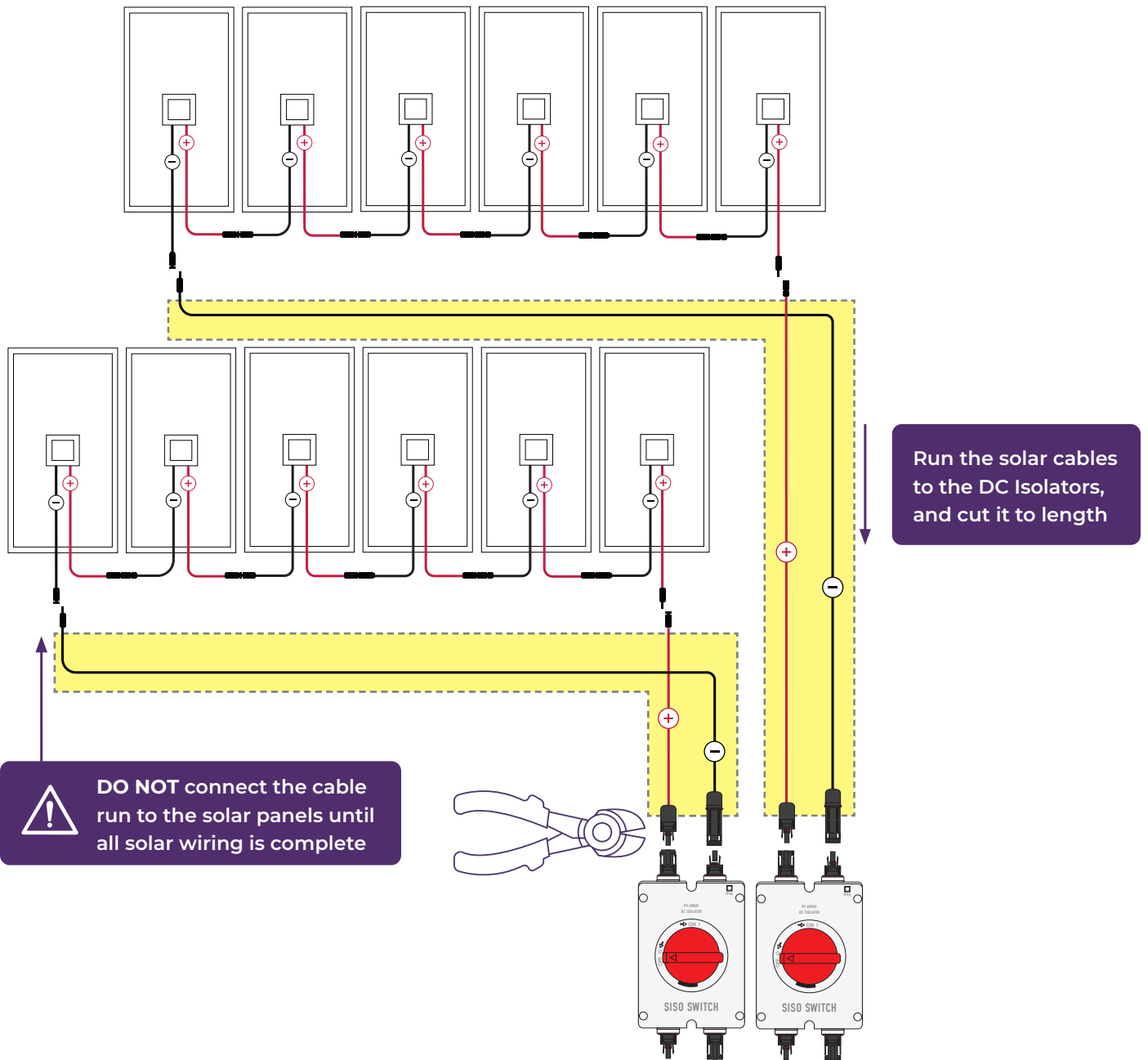

2 Run the 6mm<sup>2</sup> Solar Cables from the solar panels to the DC isolator, and cut it to length.

**DO NOT** connect the cable run to the solar panels as the cables will become live. Wait until all solar wiring is complete

The PV cable must be run inside of a suitable conduit when the cable is run across a roof, floor, or the interior of a building.



Scan the QR code to watch a demonstration video

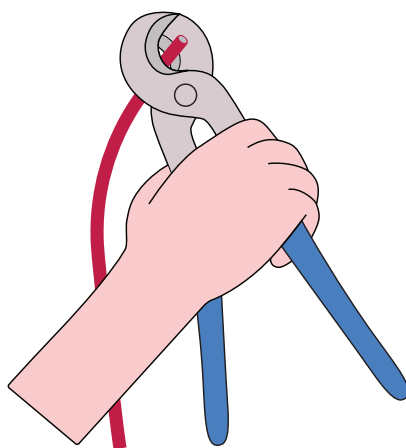

- 3 Use wire strippers to strip the ends off the black and red 6mm<sup>2</sup> solar cables. Strip the cables to approximately 7mm in length.

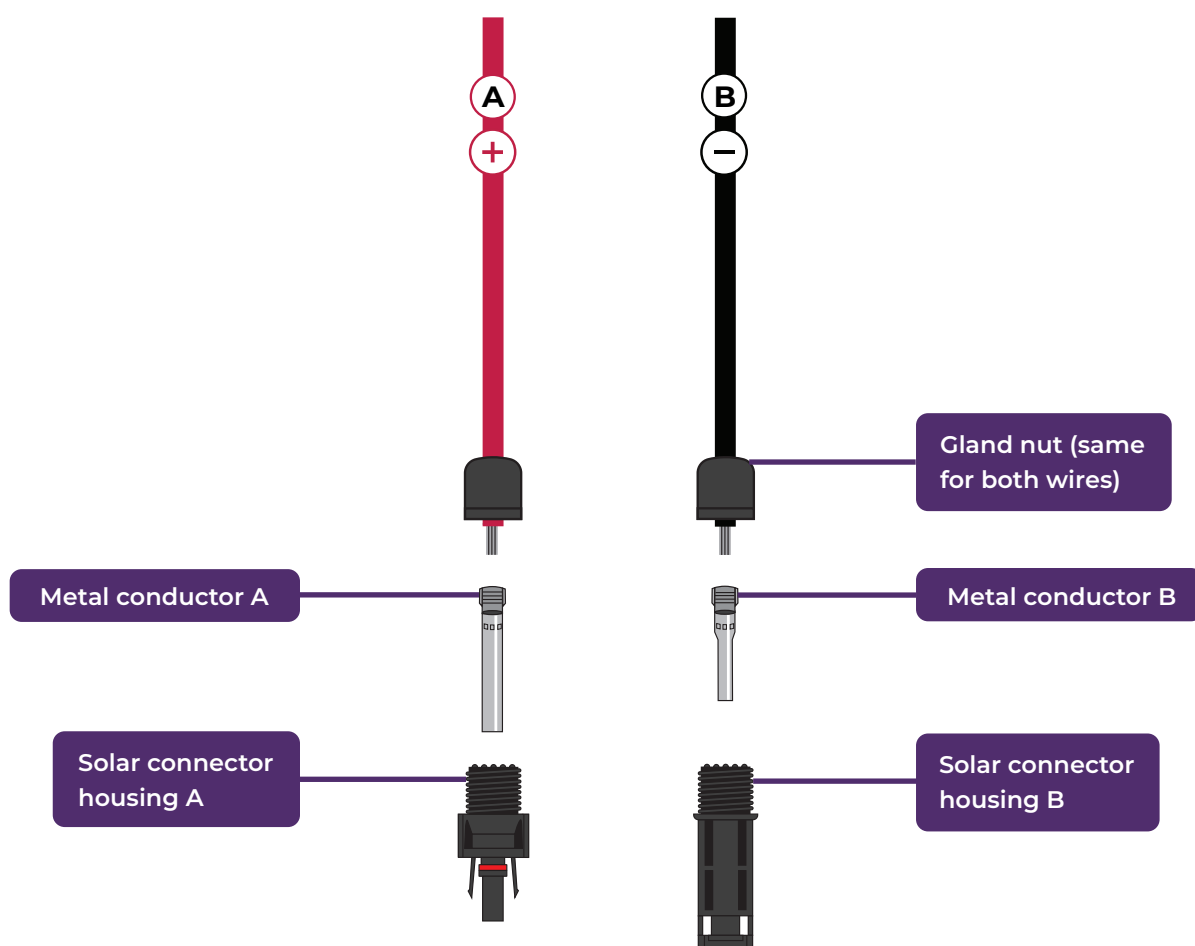

- 4 Ensure you use the correct metal crimp conductor, with the correct housing. Above demonstrates how each wire connects to its solar connector. The positive wire uses “Metal conductor A” and “Solar connector housing A”, the negative wire uses “Metal conductor B” and “Solar connector housing B”.

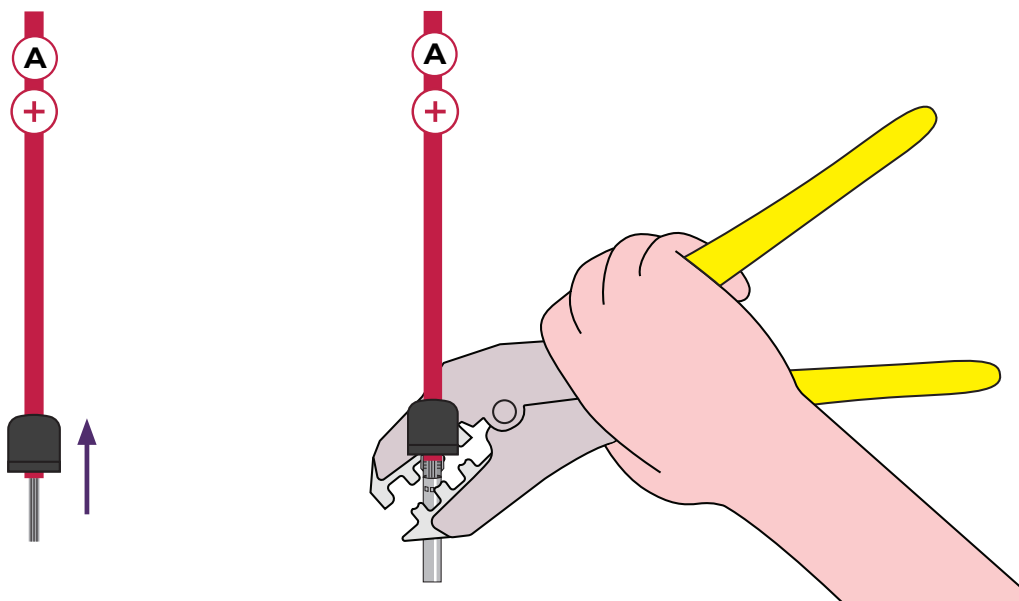

- 5 Starting with the red solar cable, place the silicon gland and gland nut onto the cable. Crimp “Metal Conductor A” onto the cable using the 6mm<sup>2</sup> crimping die.

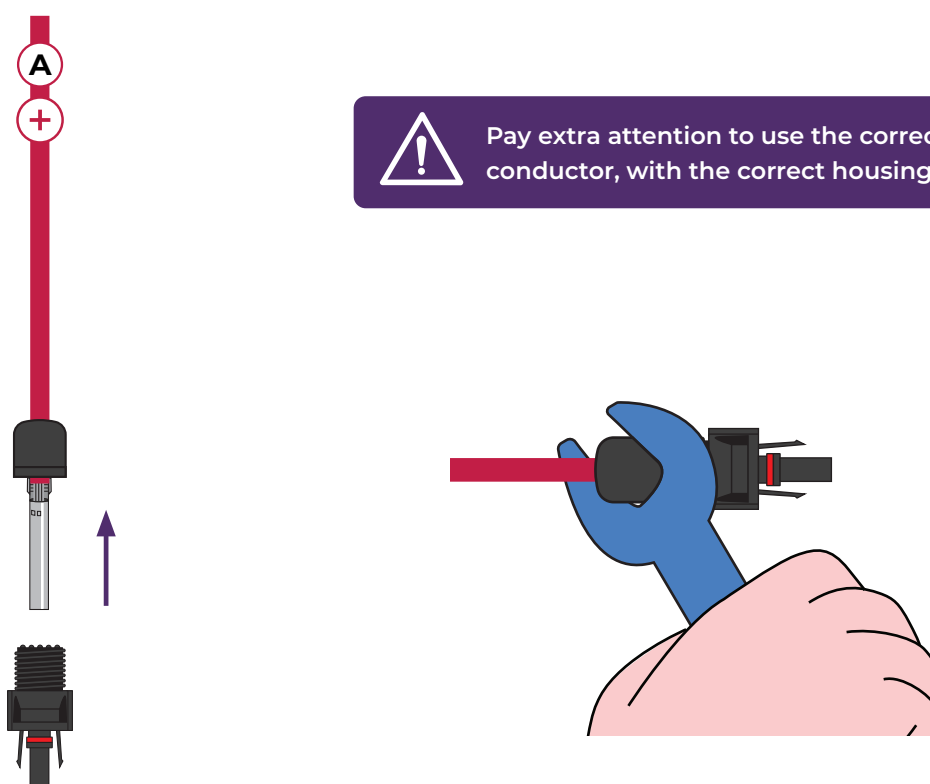

- 6 Insert the crimped “Metal conductor A” into the “Solar connector housing A” until it **clicks**, then tighten the gland nut using a spanner.

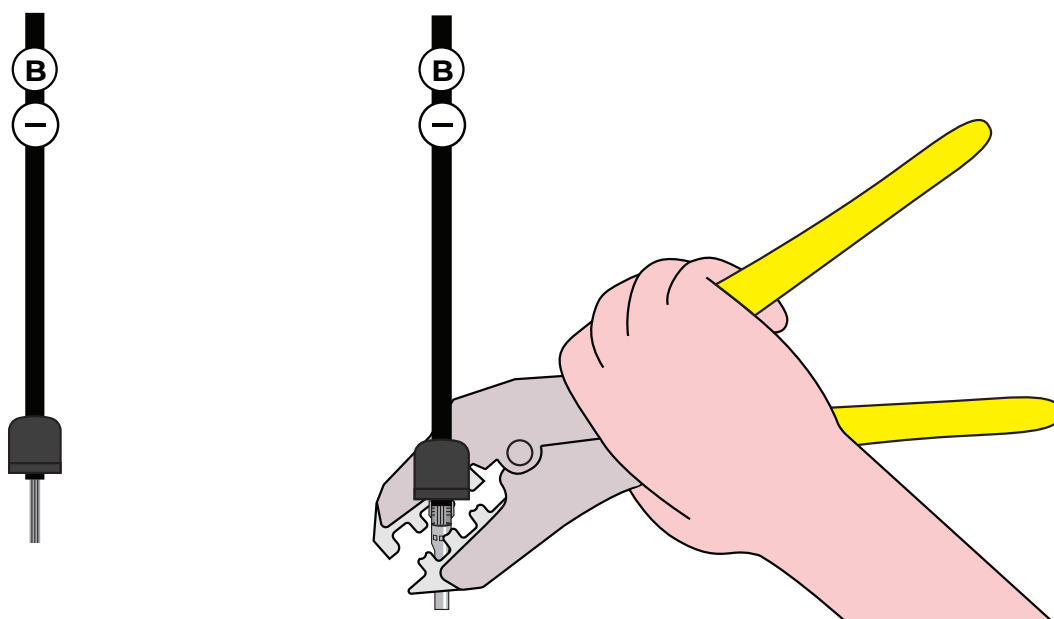

- 7 Move onto the black solar cable. Place the silicon gland and gland nut on to the cable. Crimp “Metal conductor B” onto the cable using the 6mm<sup>2</sup> crimping die.

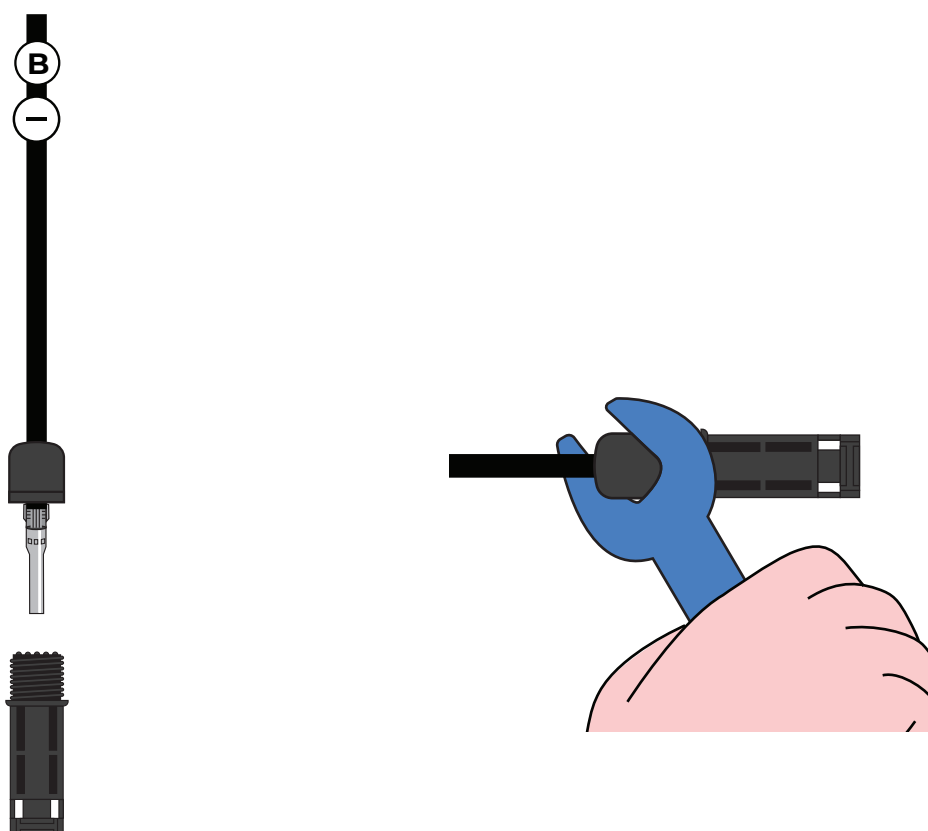

- 8 Insert the crimped “Metal conductor B” into the “Solar connector housing B” until it **clicks**, then check that the housing does not come off easily. Tighten the gland nut using a spanner.

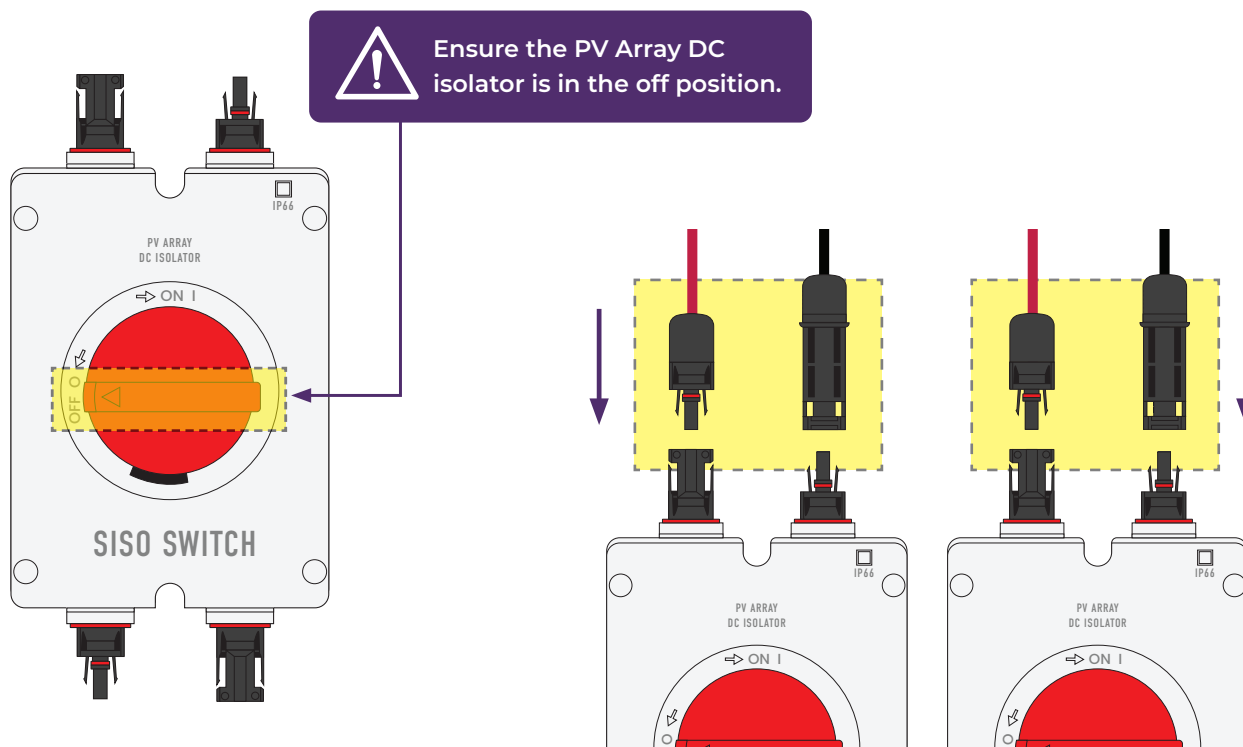

- 9 Ensure the PV Array DC isolator is in the off position. Then, connect the PV cable run from the solar panels. **Ensure the other end of the cables stay disconnected from the solar panels.**

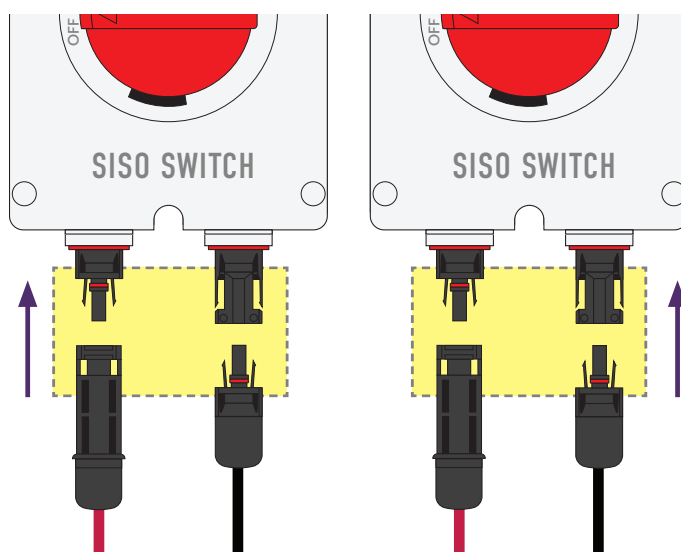

- 10 Repeat the process of crimping MC4 connectors onto a new set of cables (refer to page 9-11), which will connect the PV Array DC isolator to the PV Array fuses.

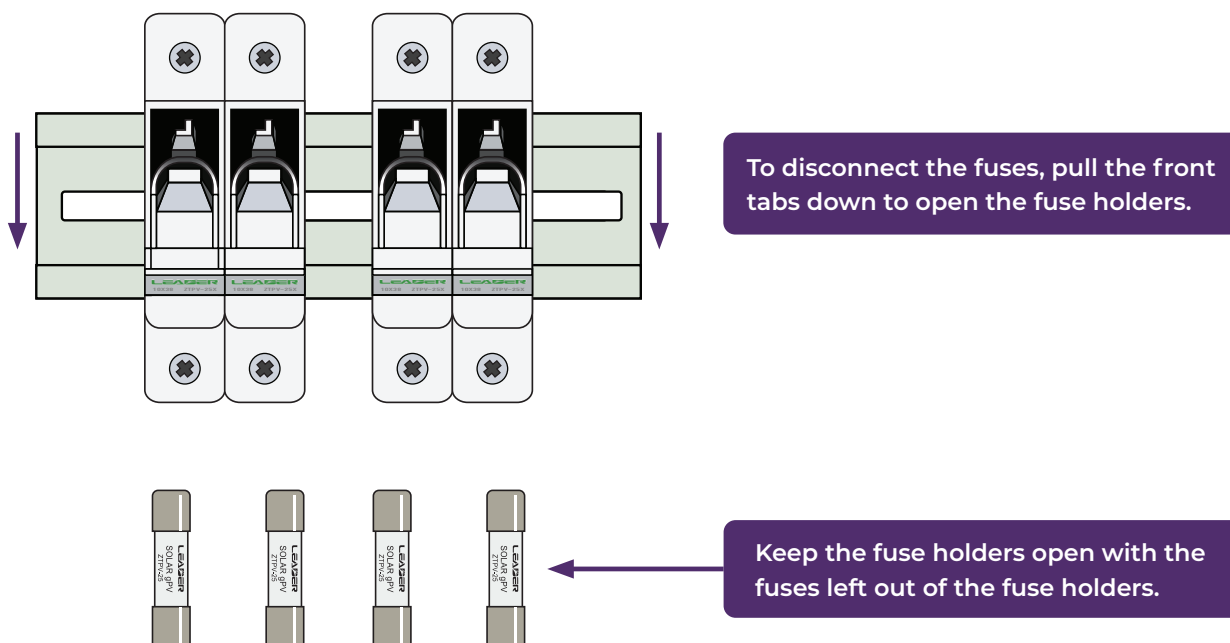

Ensure the solar cable run is **NOT** connected to the solar panels. Keep the fuse holders disconnected by keeping them open with the fuses **OUT** and the PV Array DC isolators are in the off position.

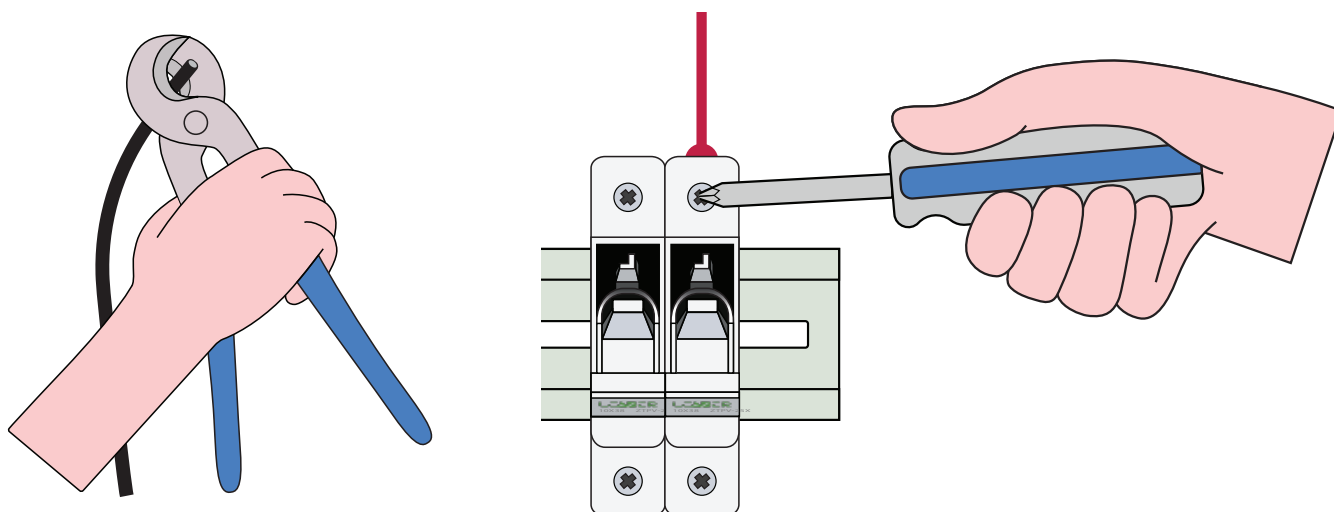

- 11** Ensure the fuse holders are disconnected by keeping them open with the fuses **OUT**. Use wire strippers to strip the ends of the solar cable, and terminate them in the fuse holders by inserting the stripped end and tightening the screw clockwise. Make sure the clamp inside the fuse holders are contacting the metal conductor, and **NOT** the insulation of the wire.

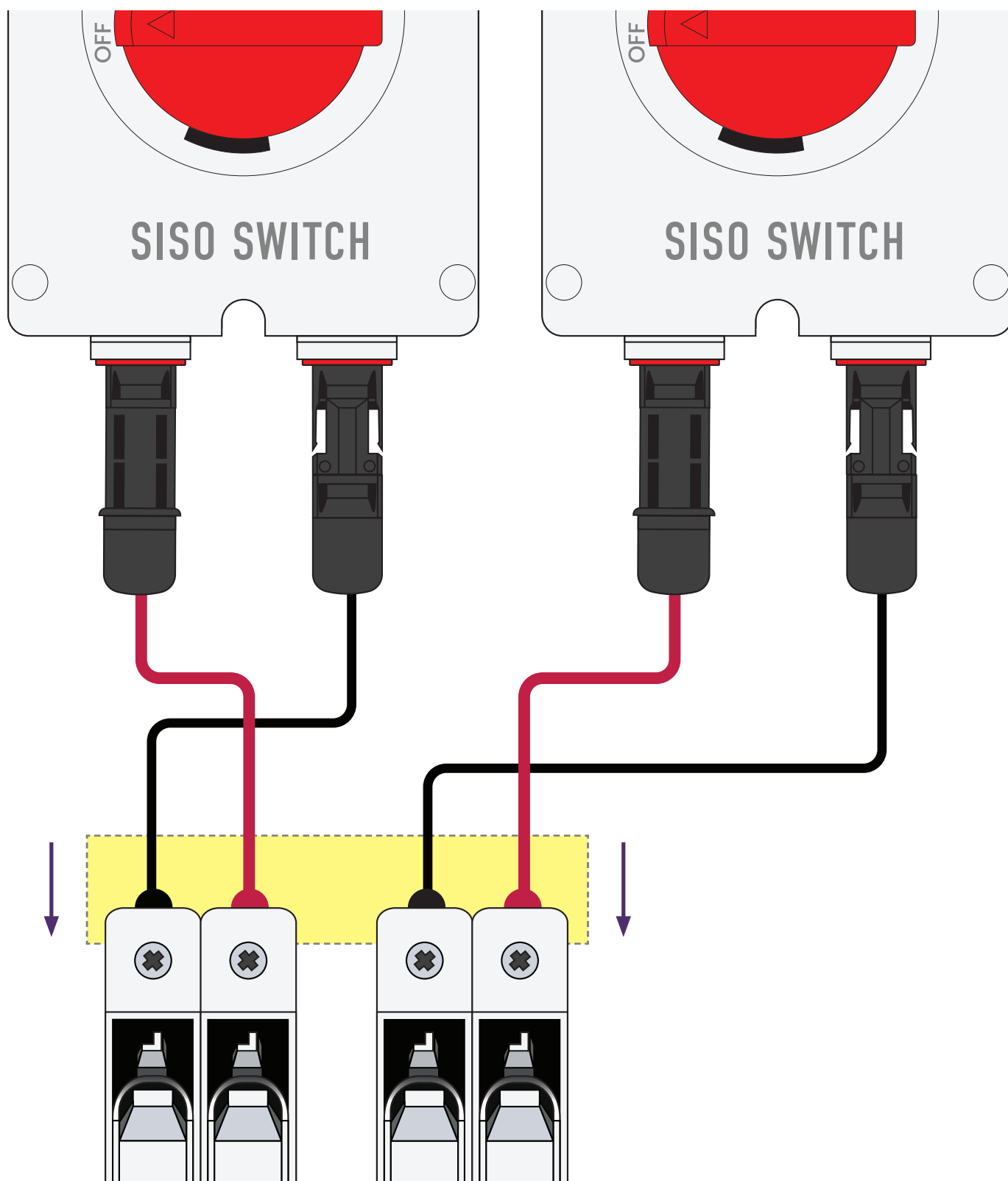

12 The PV Array DC isolator is now wired into the PV Array fuses.

# HYBRID INVERTER WIRING

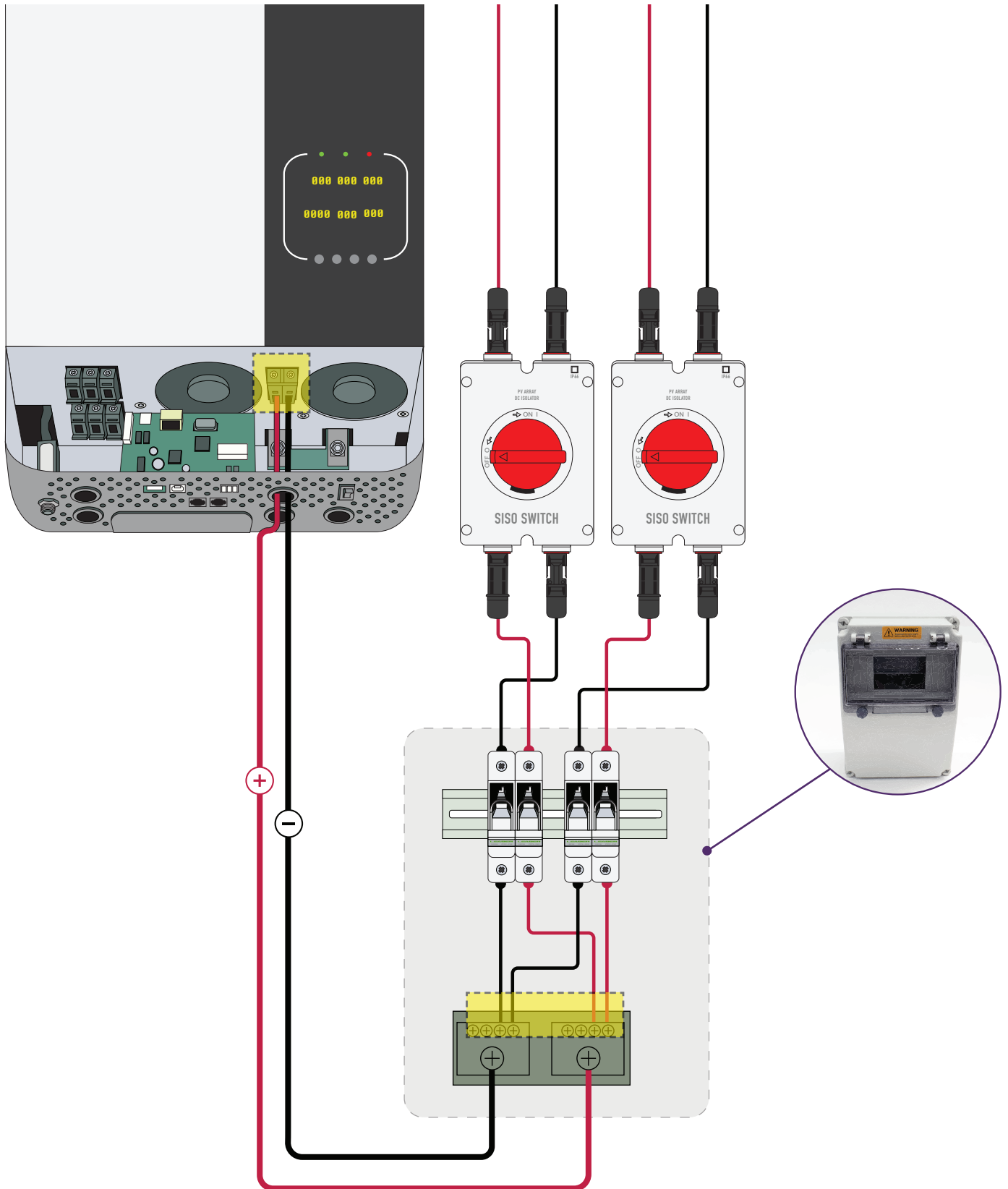

- 1 Use the green terminal combiner block to join both the negatives together in one side of the block, and both positives together in the other side. Then, run the section of 10mm<sup>2</sup> cable from the M8 bolt terminals to the hybrid inverter.



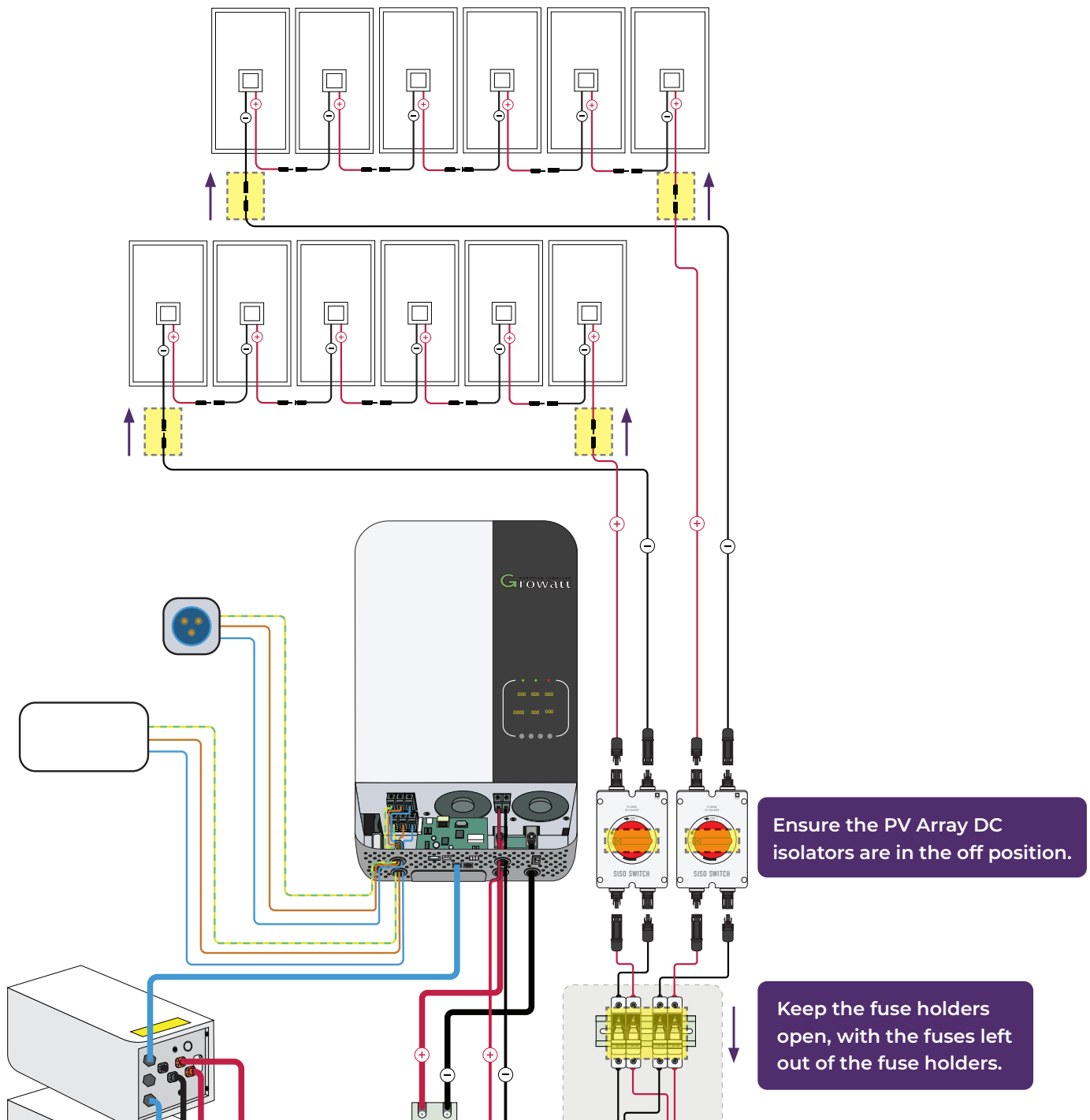

- 2 Once the cables have been terminated in the fuse holders, check the following before proceeding:
- i) the fuses are disconnected by keeping the fuse holder open and the fuses left out
  - ii) the PV Array DC Isolator switch is in the "OFF" position

The cable run can now be connected if the above criteria is met.

The fuses and DC isolator must be disconnected when connecting or disconnecting the solar panels from the cable run. For your safety, do **NOT** connect or disconnect any solar cables when there is current running through them.

 Voltage over 120V requires an electrician.

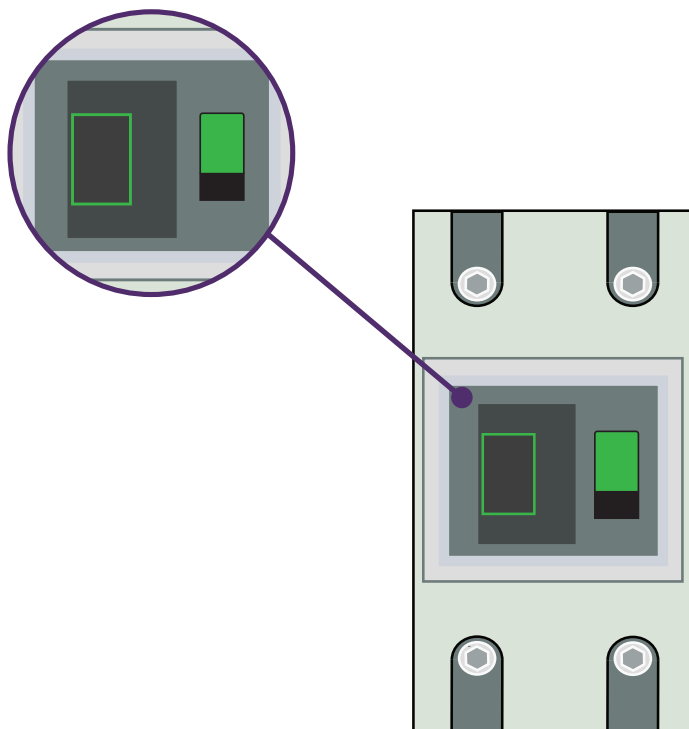

- 3 Ensure the 200A MCCB circuit breaker is switched “OFF” (switch in the down position, indicator showing green).

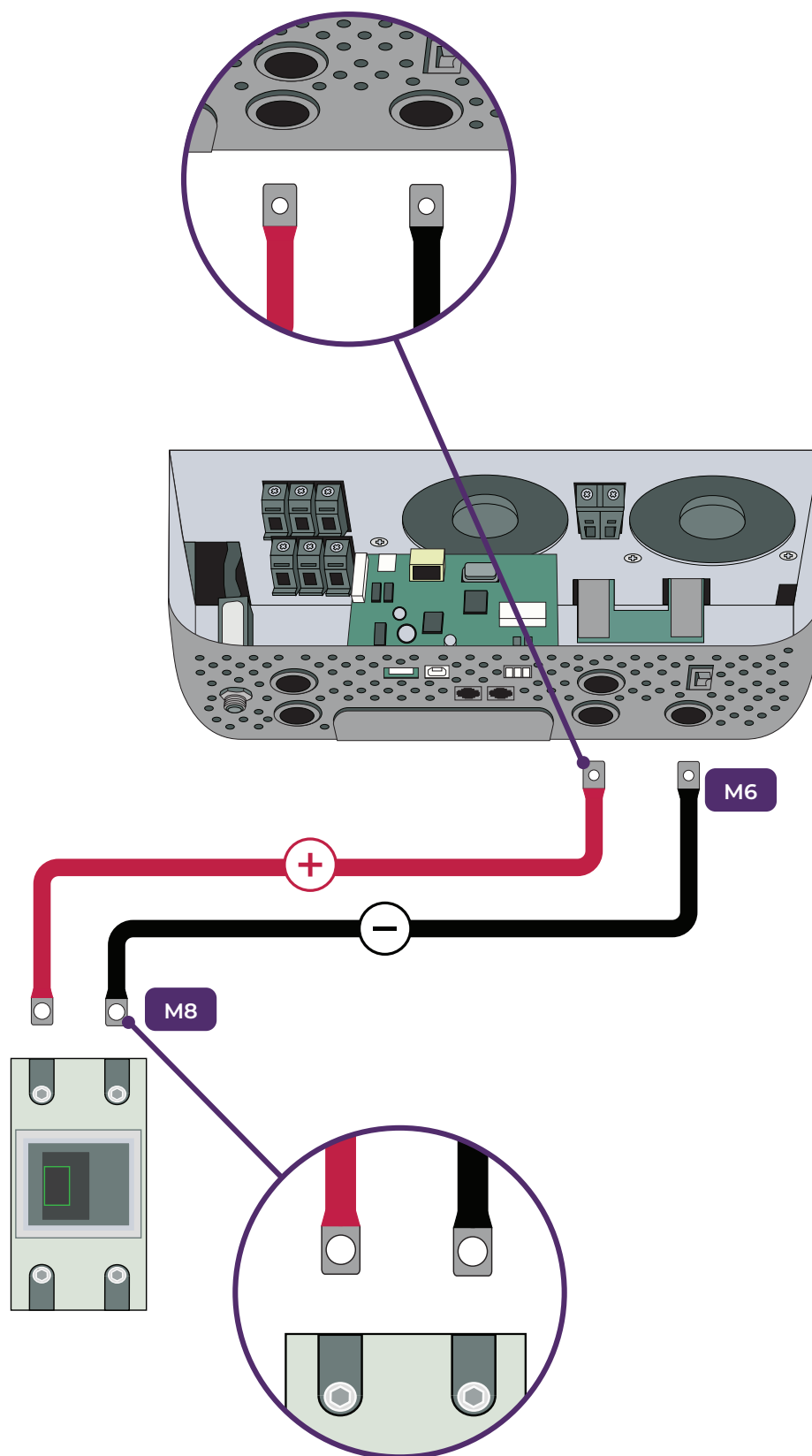

- 4 Before proceeding to connect the hybrid inverter to the 200A MCCB circuit breaker, align the 35mm<sup>2</sup> x 1m cables between the components to ensure that the M6 ends (smaller holes) are inserted into the hybrid inverter, and the M8 ends (larger holes) are inserted into the circuit breaker.

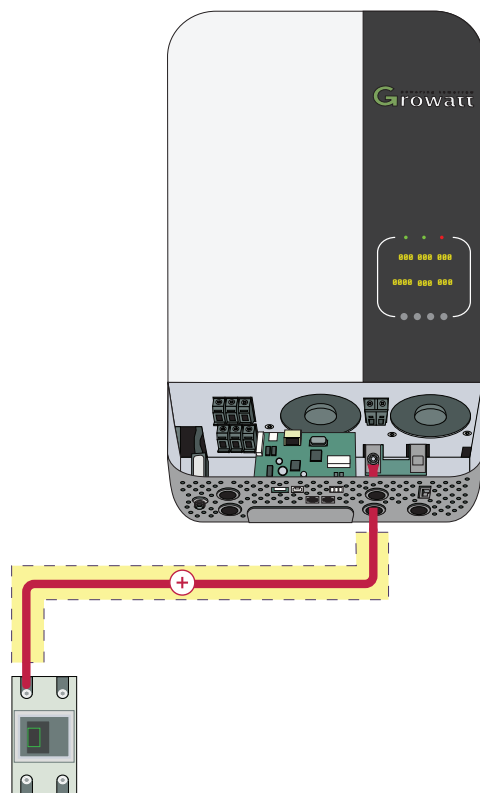

- 5 Wire the positive(+) 35mm<sup>2</sup> cable from the 200A MCCB circuit breaker to the hybrid inverter.

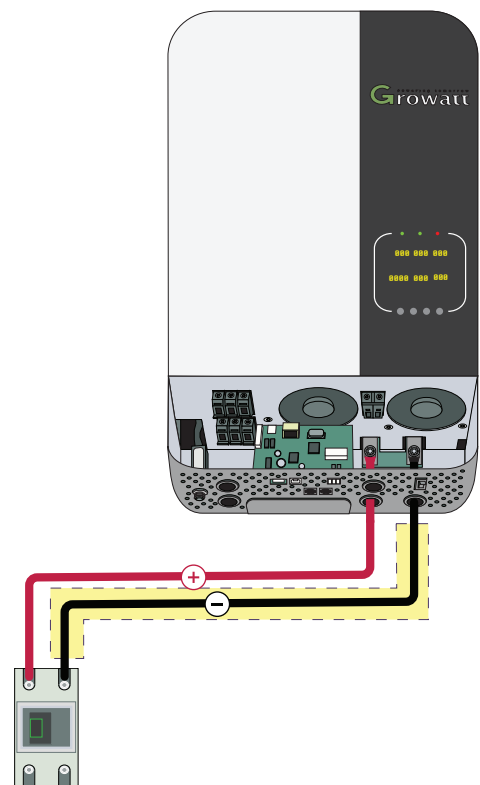

- 6 Wire the negative(-) 35mm<sup>2</sup> cable from the hybrid inverter to the 200A MCCB circuit breaker.

# BATTERY WIRING

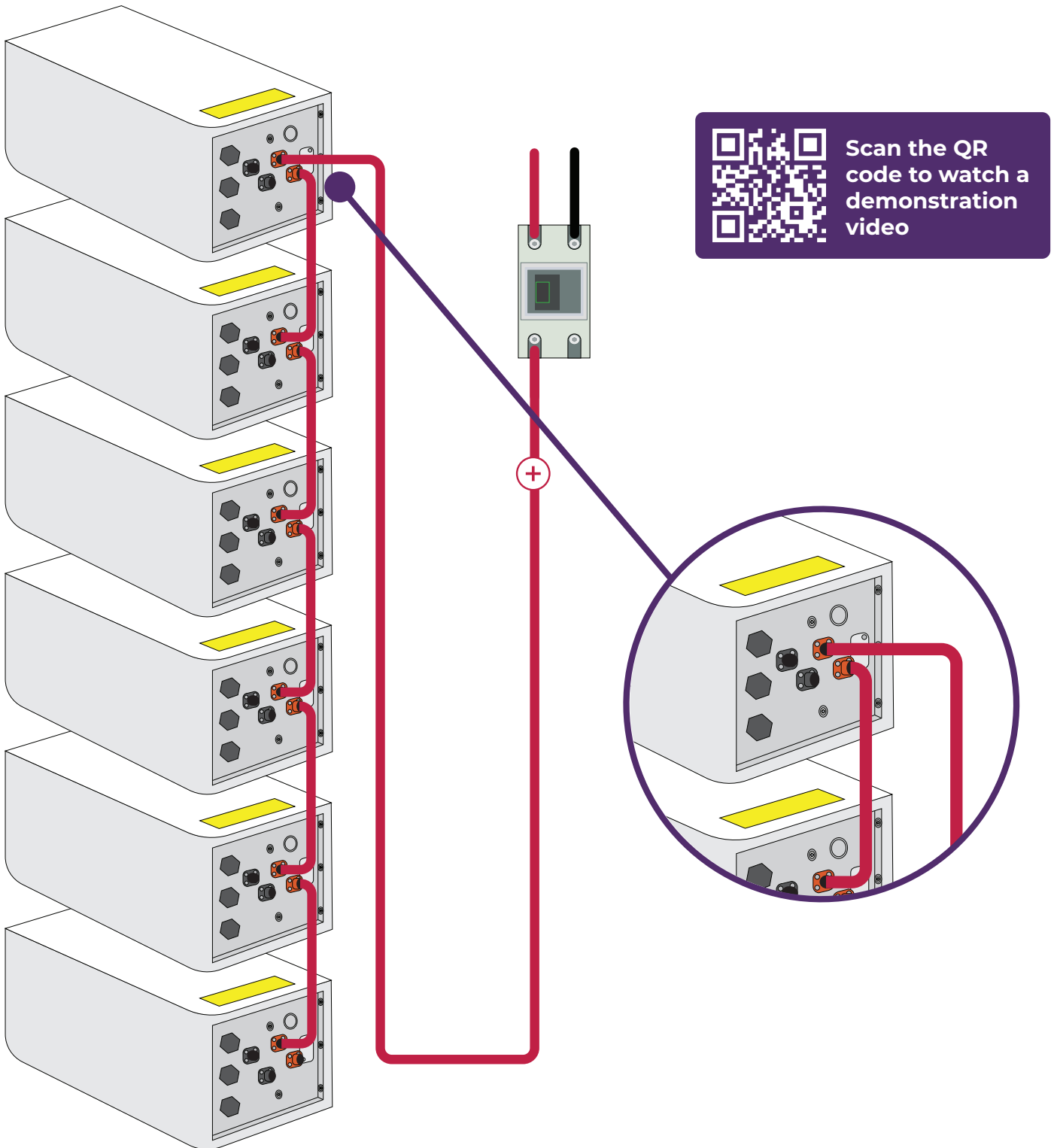

Scan the QR code to watch a demonstration video

- 1 Follow the manual included by Growatt for stacking and mounting the batteries. Using the battery cables supplied in the battery cable set and in the individual battery boxes, connect the positive terminals as shown in the diagram above.

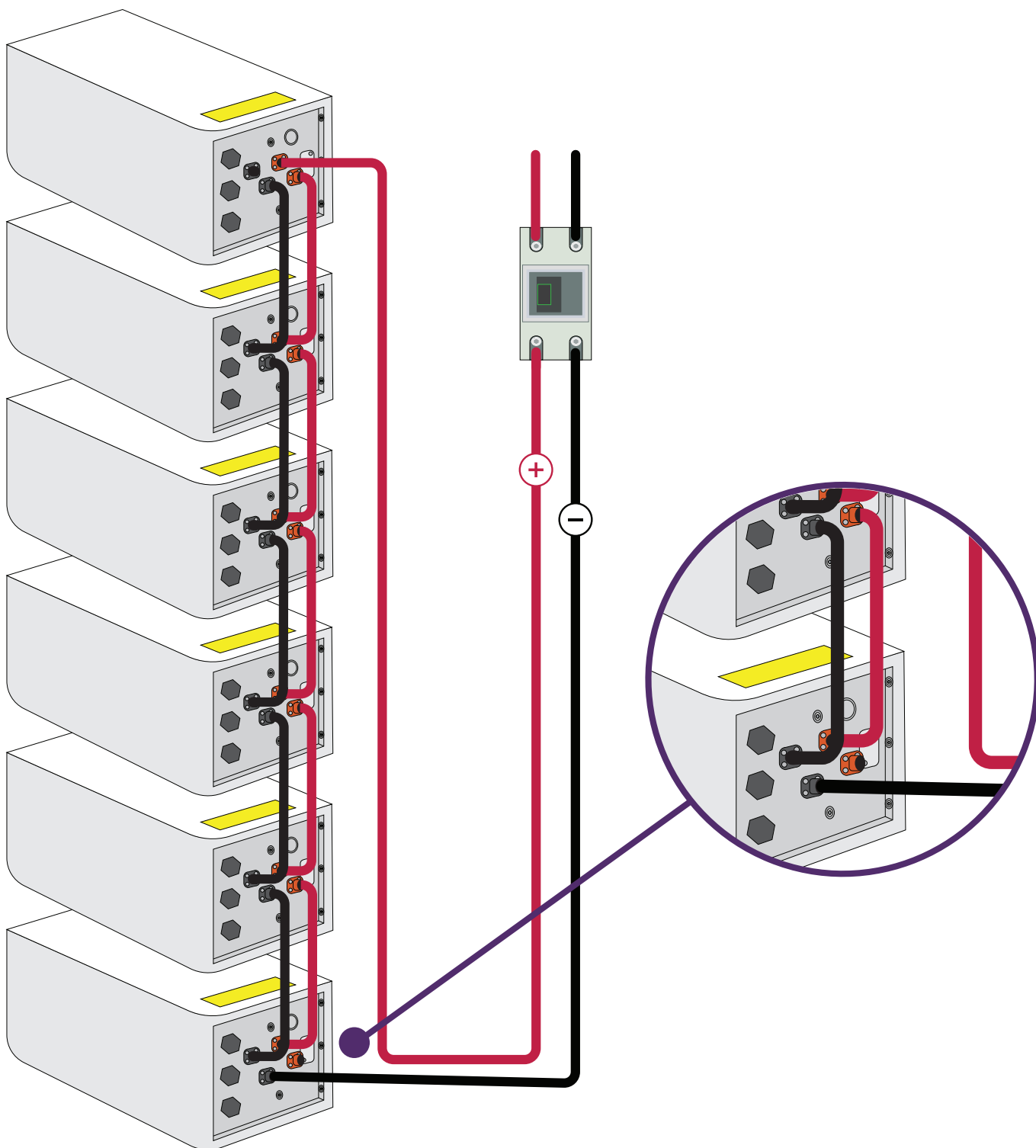

- 2 Connect the power connections, following the instructions detailed in the battery installation manual.

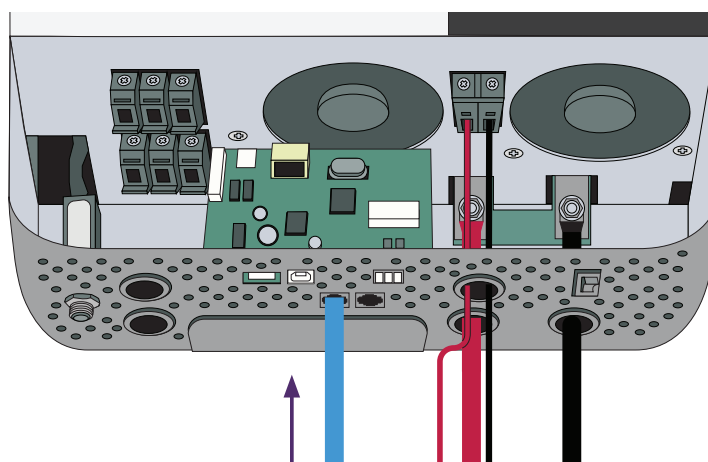
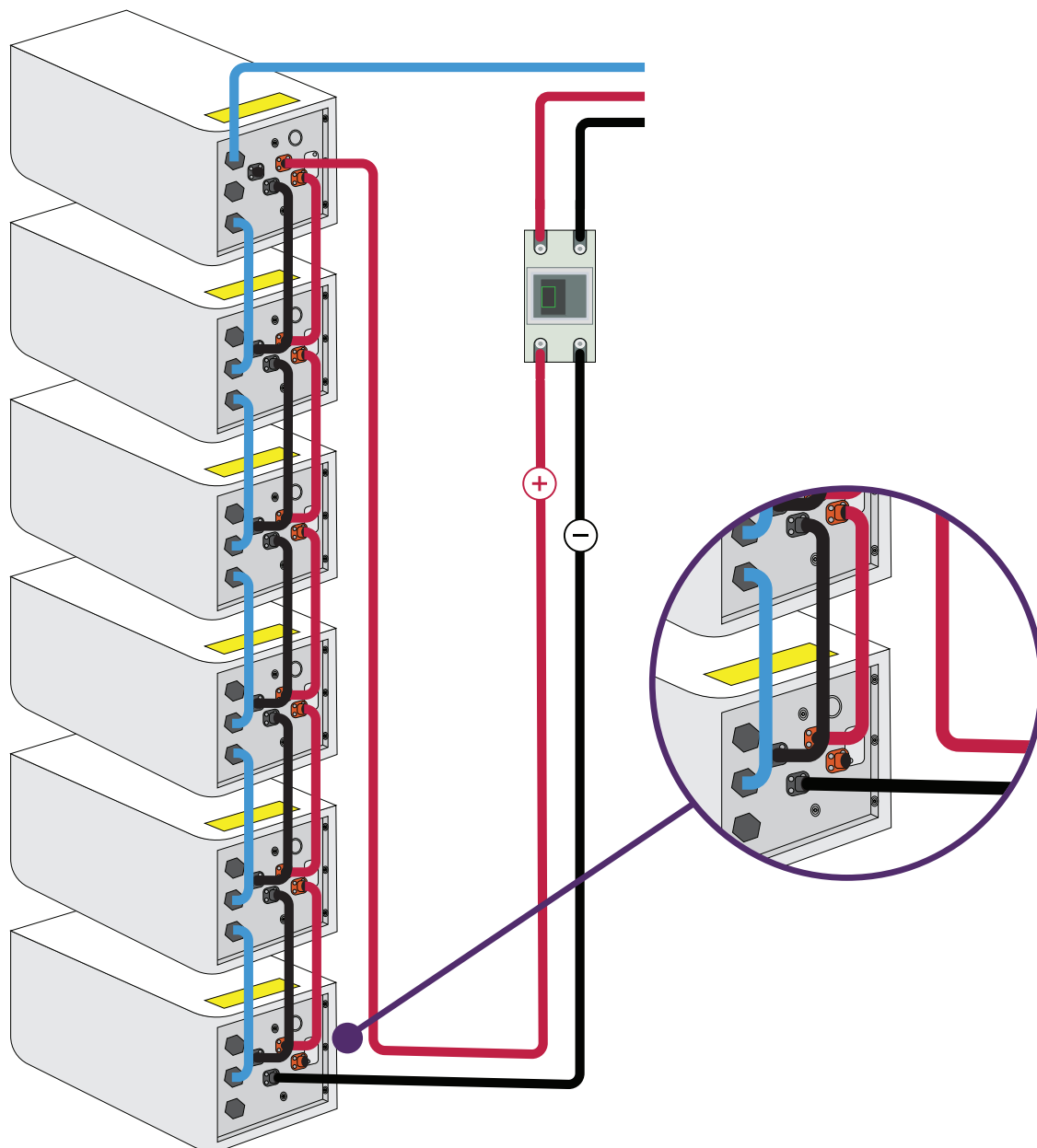

- 3 Connect the CAN communication cables as described in the battery installation manual.

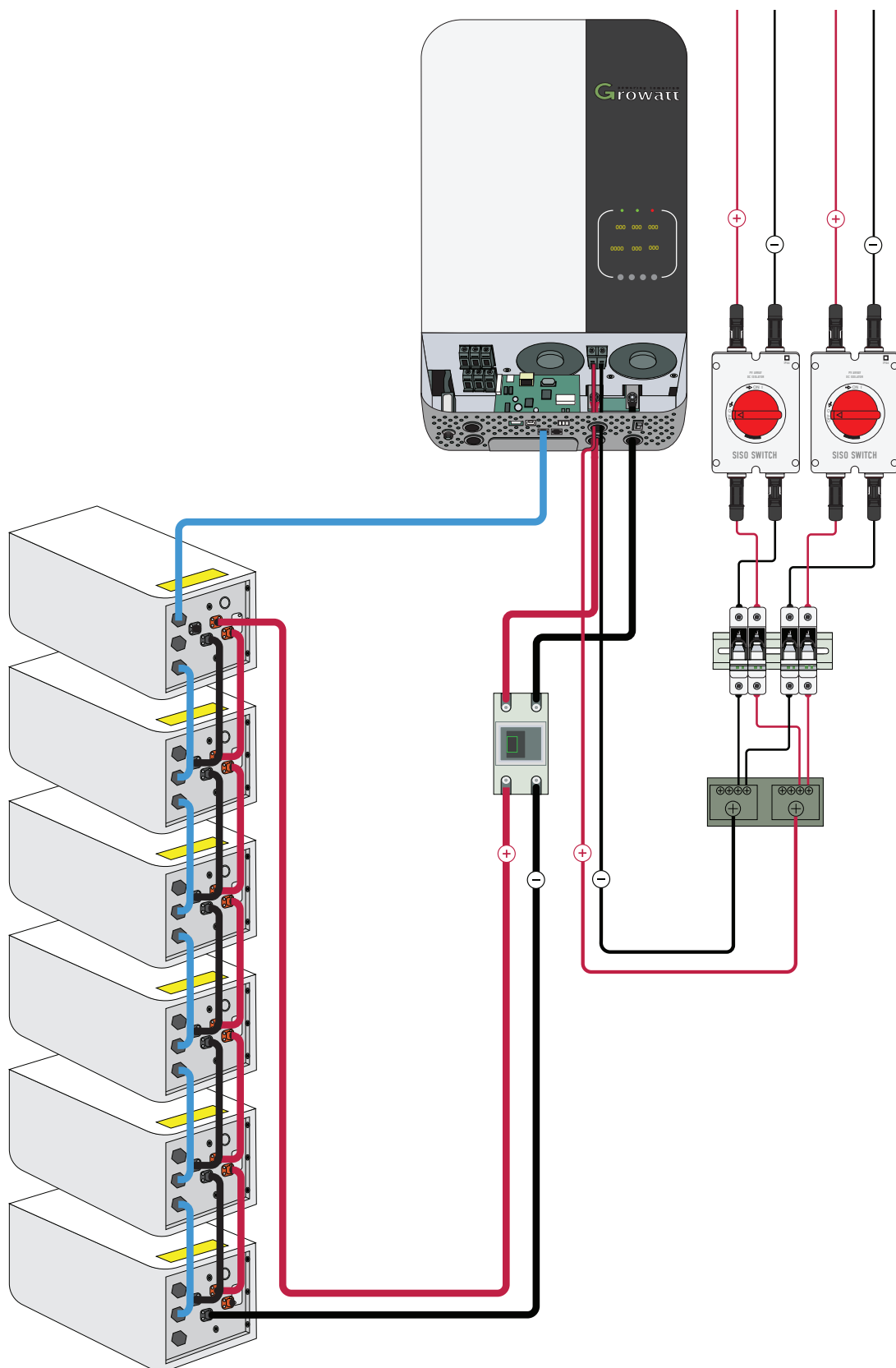

- 4 Once you have wired the batteries into the hybrid inverter, your completed wiring should look like the image above (excluding the panels). Double check everything is wired correctly and tightened before proceeding to prevent damage to your system. All steps in this manual should be done by an electrician.



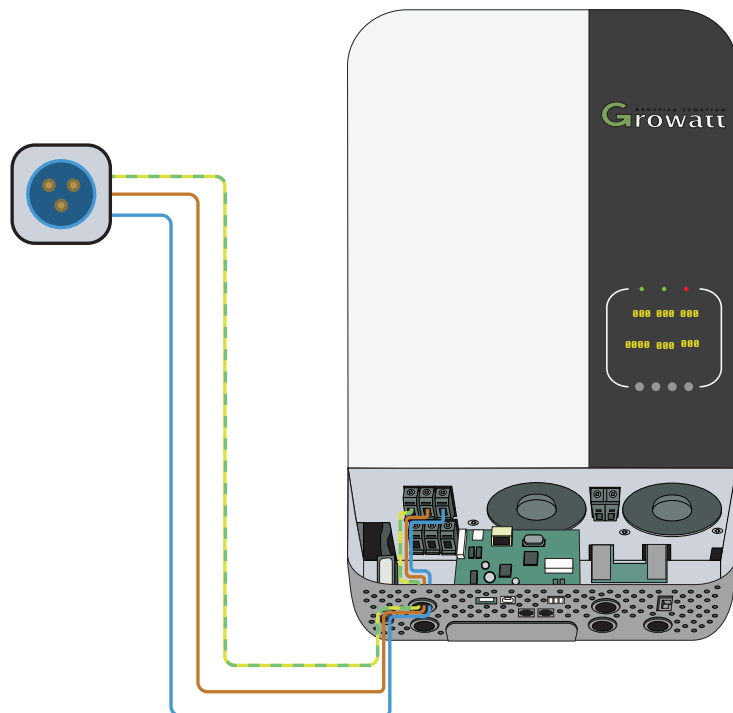

- 5 If using the utility / generator input, use components rated for 50A. If using components rated for less (e.g. a caravan plug), make sure to use an appropriately sized breaker.

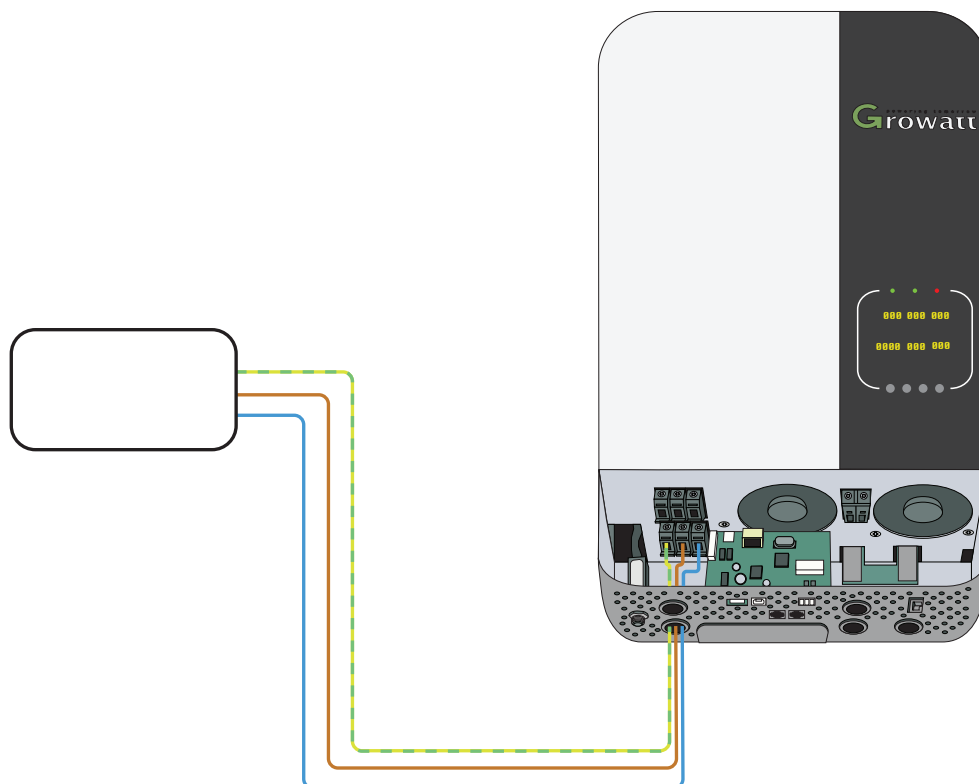

- 6 The output of the inverter is designed to wire into a distribution board.

# STARTUP PROCEDURE

---

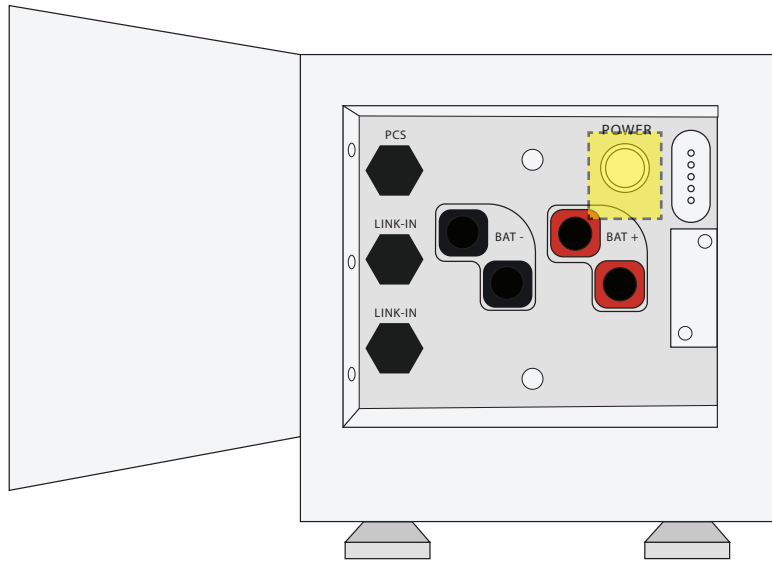

- 1 Power on all the lithium batteries by:
    - i) flicking the breaker switch at the back of the battery to "ON"
    - ii) pressing and holding the power button at the front until the green light turns on
- 

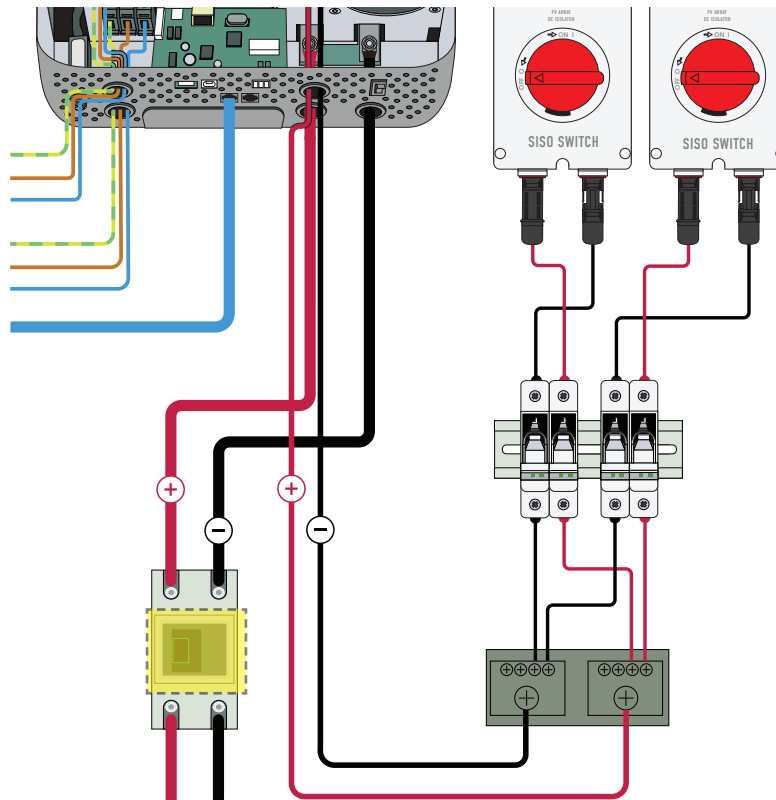

- 2 Switch on the battery to hybrid inverter 200A DC MCCB circuit breaker.
-

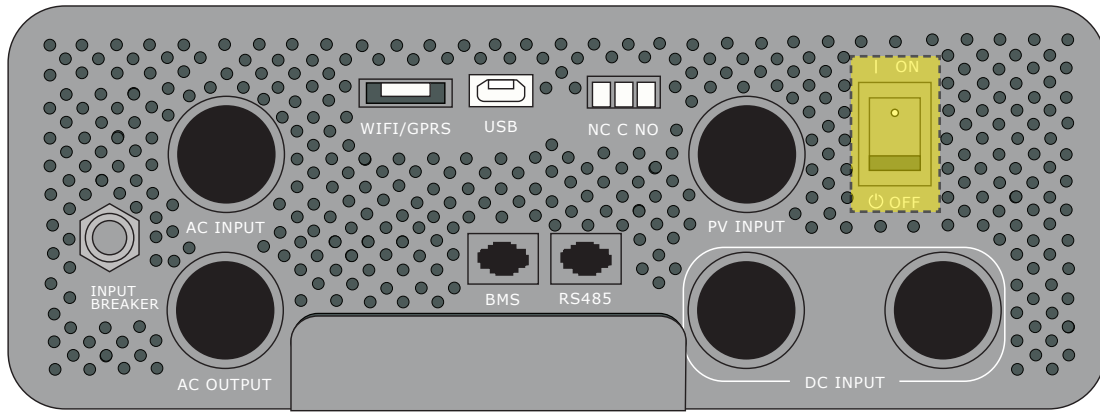

- 3 Flick the switch located at the bottom of the hybrid inverter to “ON”, and refer to the hybrid inverter manual to ensure normal operation.

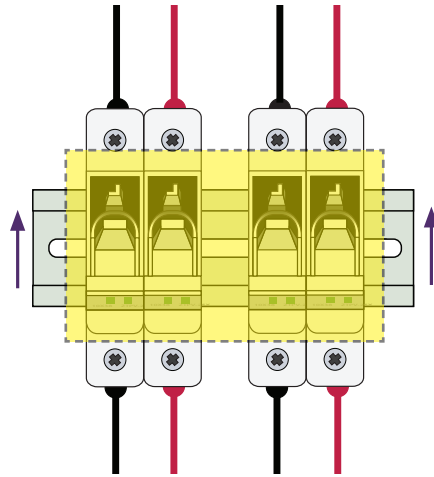

- 4 Connect the panels to the hybrid inverter by inserting the fuses into the fuse holder and closing the fuse holders.

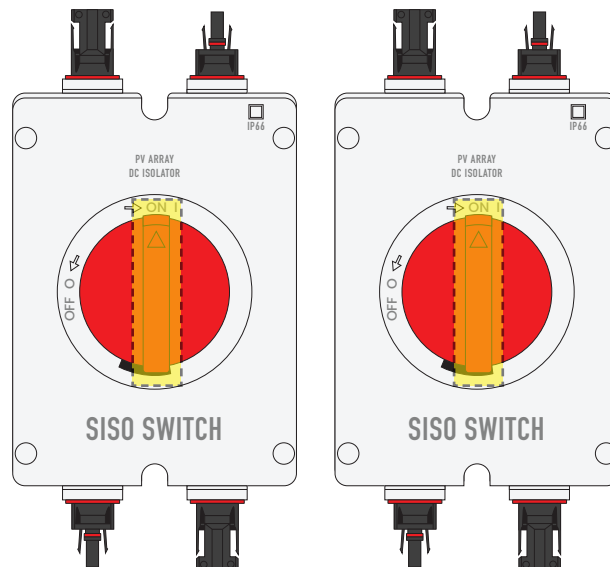

- 5 Switch the PV Array DC isolators to the “ON” position.

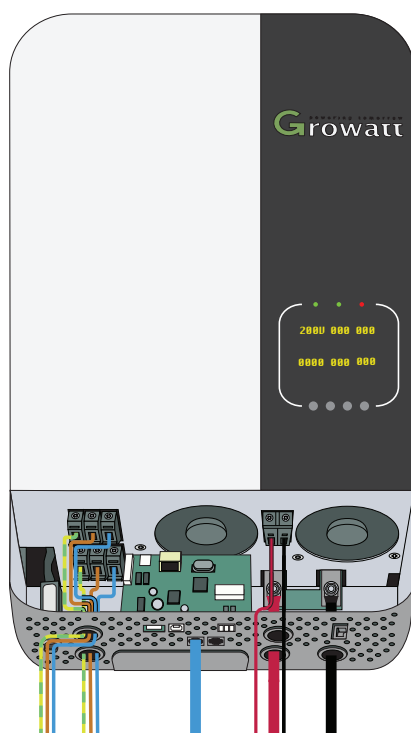

- 7 The green LED on the PV charge should be flashing, and the panel voltage should be around 180V-240V in full sunlight.



- 6
- i) Select the Lithium battery charging mode on the hybrid inverter.
  - ii) Press and hold "ENTER" for 3 seconds.
  - iii) Go to program 5 and set the battery type to "LI".
  - iv) After pressing "ENTER", it will automatically switch to Program 36.
  - v) Press "ENTER" again to enter Program 36.
  - vi) Set Program 36 to L51 and press "ESC".

If there are any issues, please check all cables and connections. Then, double check Program 5 is LI and program 36 is L51.

# TROUBLESHOOTING GUIDE

---

We've compiled this list of common problems our customers may encounter with their solar gear to help you solve any issues as fast as possible.

Please contact us if you don't find the answers you need here or if your issue continues after implementing the given solutions.

## 1. My solar panels are not putting out as much power as normal

Once you've determined the drop in power is not due to weather changes, check your panels for any shade or shadows. Check both morning and afternoon in case the shadows are inconsistent. Ensure they're adequately cleaned, as things such as thick dust or bird droppings can affect your output. Finally, double check all your connections are clean and secure.

If none of these issues are causing your power drop, you'll need to send us clear pictures of your charge controller readings. We need to see the battery voltage, solar panel voltage, and solar panel amps. Please send readings from mid-day with peak sun and the end of the day or early morning.

## 2. My inverter keeps shutting off

Check your battery voltage, as inverters have an auto shut-off feature to protect them from damage when the voltage drops too low. The manual with your inverter will have this information and a troubleshooting guide.

## 4. My batteries aren't charging

It's likely your batteries have been drawn very low and cannot charge fully if you continue to draw power. Check all the wiring is secure and undamaged, then turn off the breaker between the batteries and the inverter, leaving the others on, and let the batteries charge back up to full.

If you don't believe you have knowingly used enough power to drain the batteries, check all your appliances to see if something is using more power than it should.

---

## 5. My batteries drain very fast when the sun goes down

The controller may read 100% while charging at the higher voltage, but it will quickly drop lower when no charge is applied. This could be because the batteries charge at a higher voltage, so when the sun goes down, the battery voltage will stabilise at a lower level. It may also mean the batteries have been drained low, and they need to get more charge to be fully charged by the end of the day.

Try reducing your power usage for a few days to ensure the batteries are fully charged. You should also check that the solar panels have total sunlight exposure or whether an appliance has been left on. When customers notice less solar output, the most common cause is shading - as we transition between winter and summer, the sun's path changes and can cast new shadows across the panels, which weren't noticed when you first installed the system.

## 6. My inverter beeped, and an orange light was flashing

If you check quickly, you may hear your charge controller beep and see an orange light blinking.

This occurs when the battery voltage is too high, and the charge controller is charging the batteries completely.

This usually happens on a very sunny day or when using a high-draw appliance (e.g. toaster). When the high-draw apparatus stops, the solar works very quickly to top off the batteries and can peak the voltage briefly. As it's a smart inverter, it works to protect itself and your batteries, so it can sometimes be a little bit on the overprotective side.

## 7. My inverter fan turns on all the time

You may notice the fan turning on even when you're not using a high-load appliance. The inverter can sometimes be a little overprotective of itself, especially on warm days, and the fan will turn on when it doesn't seem necessary. Make sure there is sufficient airflow around your inverter, and you should be fine.

# CONTACT US

---

**Our website:** [gridfree.store](http://gridfree.store)

**Email us:** [info@gridfree.store](mailto:info@gridfree.store)

**Message us on Facebook:** [@GridFree.Store](https://www.facebook.com/GridFree.Store)

**Give us a call:** (09) 218 5533

**Address:** By Appointment– C4/27 Smales Road, East Tāmaki, Auckland, 2013

**Hours:** 9am-5pm, Monday-Friday

Kit viewings, demos, and pick ups at Auckland warehouse by appointment only.  
Please give us a call and we'll be happy to set up a time to meet you.

---



GRIDFREE