



🔍 Growatt New Energy



Residential Energy Storage User Manual ALP 5.0 ~ 40.0L AU Series Battery System

Shenzhen Growatt New Energy Co., Ltd
4-13/F, Building A, Sino-German (Europe) Industrial Park,
Hangcheng Ave, Bao'an District, Shenzhen, China
T +86 755 2747 1942
E service@ginverter.com
W www.ginverter.com
GR-UM-308-A-00

Contents

About this Document

This document describes the ALP 5.0L-E1- AU Battery System (short for ALP 5.0L) in terms of its installation, electrical connection, operation, commission, maintenance, and troubleshooting.

Before installing and operating ALP 5.0L, ensure that you are familiar with product features, functions, and safety precautions provided in this document.

Symbol	Description
 WARNING	Indicates a potentially hazardous situation, if not avoided, could result in serious injury or death.

1 Product Overview

- 1.1 Intended Use
- 1.2 Appearance
- 1.3 Working Principle and Function

2 Safety

- 2.1 General Safety
- 2.2 Safety Precautions
- 2.3 Warning Labels
- 2.4 Emergency Responses

3 Storage and Transportation

- 3.1 Storage Requirements
- 3.2 Transportation Requirements

4 Installation

- 4.1 Installation Environment
- 4.2 Basic Installation Requirements
- 4.3 Installation Required Tools
- 4.4 Check
- 4.5 Installation

5 Power on and off the Battery System

- 5.1 Power On
- 5.2 Power Off

6 Maintenance Guide

- 6.1 Preparation
- 6.2 PACK Replacement
- 6.3 System Failure Information List and Troubleshooting Suggestions
- 6.4 About mixing old and new batteries in parallel

7 Technical Specifications

- Appendix I
- Appendix II

1 Product Overview

1.1 Intended Use

Each ALP 5.0L consists of 100Ah cells which form a 51.2V voltage battery module and sixteen serial connection (1P16S). A single cluster can connect up to 8 batteries in parallel to expand the capacity and power of the energy storage system. Battery modules of the same type can be connected in parallel regardless of its software version. Specifically, the ALP battery system powers the loads through PCS at nighttime without solar; when solar becomes available during daytime, solar energy powers the loads as a priority and the surplus solar power is stored in the ALP battery system.

1.2 Appearance

ALP 5.0L consists of the battery module (including cells and mechanical parts), battery management system (BMS) as well as power and communication terminals. Product appearance is shown as below.

1.2.1 Dimensions

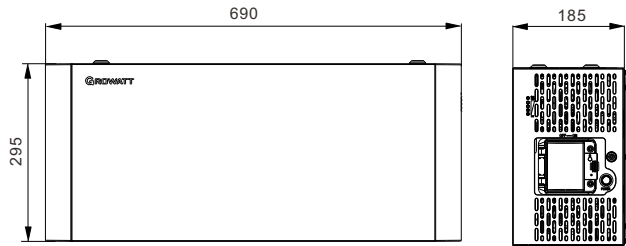

Fig 1.1: Dimensions of the battery module

1.2.2 Introduction to the battery operation panel

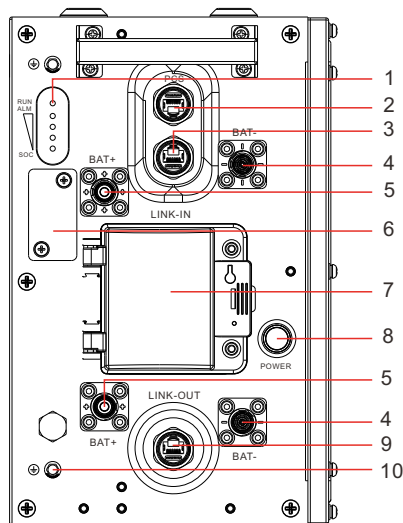

Fig 1.2: Introduction to the battery operation panel

NO.	Description	NO.	Description
1	LED	6	USB interface
2	PCS CAN communication	7	DC breaker
3	LINK-IN CAN communication	8	Power button
4	Negative terminal	9	LINK-OUT CAN communication
5	Positive terminal	10	GND terminal

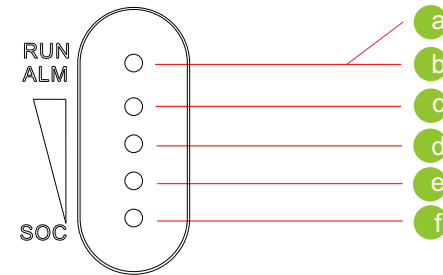

Fig 1.3: LED lights

No.	Name	Color	Description
A	RUN	Green	Normal operation
B	ALM	Red	Failure or protection status
C	LED 4	Blue	76%-100%
D	LED 3	Blue	51%-75%
E	LED 2	Blue	26%-50%
F	LED 1	Blue	0%-25%

1.3 Working Principle and Function

ALP 5.0L is an energy storage unit composed of electrochemical cells, the switch button, the battery management unit, power and signal terminals, and mechanical parts.

ALP 5.0L distinguishes itself with better charging and discharging performance, precise status monitoring, longer cycle life, and less self-discharge loss.

ALP 5.0L enables to connect 8 battery modules in parallel, expanding the capacity and power of the energy storage system greatly.

The whole battery system communicates to Power Conversion System (PCS) via CAN.

- Monitoring: Detect the voltage, current and temperature of each cell and the PACK.
- Protection and Alarm: Generate alarms and provide protection in the cases of over-voltage, under-voltage, over-current, over-temperature or under-temperature.
- Report: Report all alarms and status data to PCS.
- Power failure triggered by fault: Communications between the PACK and PCS is lost for 25 minutes or under-voltage protection for 2 minutes

2 Safety

Observe all the safety precautions provided in this section when performing operations on the batteries. To prevent personal injury and device damage, installation and operation personnel must be familiar with this manual and the precautions required.

2.1 General safety

The PACK has been designed and tested with strict adherence to the international safety certification requirements. Read all safety instructions carefully before performing operations on the equipment and observe the rules. Growatt shall not be liable for any consequence of the following circumstances:

- Damage occurred during transportation.
- Damage caused by improper operations in transportation, storage, installation and use, or the third party fails to convey the correct information about transportation, storage, installation and use to terminal customers.
- Improper installation by unprofessional and unreliable personnel.
- Failure to follow the operation instructions and safety precautions provided in this document.
- Unauthorized modifications or removal of the software package.
- The PACK tamper label is damaged or any item is missing due to customer's negligence or intentional damage.
- Operate and use in environments that cannot meet the requirements specified in this document.
- Damage caused by repairing, disassembling, or altering PACKs without authorization.
- Damage to labels on the shell or altering the date of production.
- PACKs fail to be charged for more than six months.
- Damage due to force majeure (such as lightning, earthquakes, fire, and storms).
- Warranty expiration.

2.2 Safety Precautions









2.2.1 Environment requirements





- Do not expose the battery to temperature above 50°C or heat sources.
- Do not install or use the battery in a wet environment with moisture, corrosive gases or liquids, such as in the bathroom.
- Do not expose the battery to direct sunlight for extended periods of time.
- Place the battery in a safe place and ensure that it is not accessible to children and animals.
- Battery power terminals shall not come in contact with conductive objects such as wires.
- Do not dispose of the battery in fire, which may cause an explosion.
- The battery system must be protected from liquids.
- For indoor installation, do not install it in the bedroom, the living room and the kitchen, etc.

2.2.2 Operation Precautions

- Do not touch the PACK with wet hands.
- Do not disassemble the PACK without permission.
- Do not crush, drop or pierce the PACK and the batteries.
- Dispose of the batteries according to local safety regulations.
- Store and recharge batteries in accordance with this manual.
- Ensure that the ground cable is securely connected.
- Remove all metal objects such as watches and rings that could cause a short circuit before installation, replacement and maintenance.
- The Pack must be repaired, replaced or maintained by qualified and well-trained personnel.
- When storing or handling batteries, do not stack batteries without package.
- Handle the battery with caution to avoid leakage. The leaked electrolyte is toxic and harmful to the skin and eyes.
- Packaged batteries should not be stacked more than specified number stipulated on the packing case.
- Do not use damaged, faulty or deformed batteries, which may lead to safety hazards, such as leakage of corrosion materials, electric shock and fire.

2.3 Warning Labels/Étiquettes d'avertissement

Symbols/ Symboles	Description
	Do not dispose of the battery with the household waste but in accordance with the local regulations
	Lithium ion battery can be recycled
	Certification in European union area
	UK certification
	Electric shock hazard
	Explosive gas
	May leak corrosive electrolyte
	Caution! Unassisted lifting can cause injury

Symbols/ Symboles	Description
	Keep the Pack away from children
	Ensure that the positive and negative terminals are correctly connected
	Australia RCM (Regulatory Compliance Mark)
	Keep away from open flame or ignition sources
	Observe the manual

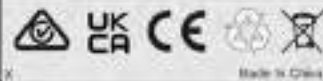
GROWATT Lithium Ion Battery	
Model	ALP 5.0L-E1
Nominal Voltage	51.2V
Nominal/Rated Capacity	100Ah/50Ah
Nominal/Rated Energy	5100Wh/4900Wh
Rated Current	75A
Ingress Protection	IP66
Operating Ambient Temperature	0°C ~ +50°C
Protective Class	I
Maximum Short Current and Duration	650A, 50us
	

Battery Module

GROWATT Lithium Ion Battery	
System Model/ Rated Current/ Nominal Capacity/ Rated Capacity/ Nominal Energy/ Rated Energy	<input type="checkbox"/> ALP 5.0L-E1/75A/100Ah/ 90Ah/5.0kWh/4.6kWh
	<input type="checkbox"/> ALP 10.0L-E1/100A/200Ah/ 180Ah/10.0kWh/9.2kWh
	<input type="checkbox"/> ALP 15.0L-E1/100A/300Ah/ 270Ah/15.0kWh/13.8kWh
	<input type="checkbox"/> ALP 20.0L-E1/100A/400Ah/ 360Ah/20.0kWh/18.4kWh
	<input type="checkbox"/> ALP 25.0L-E1/100A/500Ah/ 450Ah/25.0kWh/23.0kWh
	<input type="checkbox"/> ALP 30.0L-E1/100A/600Ah/ 540Ah/30.0kWh/27.6kWh
	<input type="checkbox"/> ALP 35.0L-E1/100A/700Ah/ 630Ah/35.0kWh/32.2kWh
<input type="checkbox"/> ALP 40.0L-E1/100A/800Ah/ 720Ah/40.0kWh/36.8kWh	
Nominal Voltage	51.2V
Ingress Protection	IP 66
Operating Ambient Temperature	0°C ~ +50°C
Protective Class	I
	

System Module

 **WARNING**

- Do not disassemble or alter the PACK to avoid heat ,explosion or fire.
- Do not use the PACK beyond specified conditions. It might cause heat generation, damage, or deterioration of its performance.
- Do not throw, drop, hit, drive a nail in, stamp on the PACK. It may cause heat generation, explosion, or fire.
- In case of electrolyte leakage, keep leaked electrolyte away from contact with eyes or skin. immediately clean with water and seek help from a doctor.
- Do not put the PACK into a fire. Do not use it or leave it on a place near fire, heaters, or high temperature sources. It may cause over temperature, explosion or fire.
- Do not submerge the PACK in water, or wet the product. It may cause heat generation, explosion , or fire.
- Do not reversely connect the PACK positive(+)and negative(-)terminal.
- Do not short circuit by letting the PACK terminals(+ and -)contact a wire or any metal.
- The unit is heavy enough to cause severe injury.
- Keep out of reach of children or animals.



Fig 2.2: Label

2.4 Emergency Responses

The manufacturer has taken foreseeable risk scenarios into consideration and designed the battery system to mitigate the hazards. In case of an emergency, do as below :

Emergency	Description and measures
Leakage	Avoid contact with leaked liquids or gases. Should you come into direct contact with the battery electrolyte, do as follows: Inhalation : Evacuate the contaminated area, and seek medical help. Eye contact: Flush your eyes with flowing water for 15 minutes, and seek medical help. Skin contact: Wash the affected area with soap and water, and seek immediate medical attention. Ingestion : Spit it out, and seek immediate medical attention.
Fire	Under normal circumstances, the PACK won't ignite spontaneously. If a fire occurs, do not try to extinguish the fire but evacuate people immediately.
Wet Packs	If the PACK is soaked or submerged in water, do not touch the batteries to avoid electric shock. Contact Growatt or your distributor immediately for technical assistance.
Damaged PACKS	Damaged PACKS are dangerous and must be handled with extra attention. Do not use damaged PACKs, which may cause safety hazards. Contact Growatt or a distributor to dispose of them.

3 Storage and Transportation

3.1 Storage Requirements

- Place the PACK following the identification on the packing case during storage.
 - Do not put the PACK upside down or sidelong.
 - Do not store damaged PACKS near undamaged PACKS.
 - The storage environment requirements are as follows
 - 1) Install the PACK in a dry, clean and well-ventilated place.
 - 2) Recommended storage temperature: -20° C to 50°C (storage period: one week), -20°C to 40°C (storage period: over 6 months).
 - 3) Relative humidity: 5%~95%RH.
 - 4) Place the PACK away from corrosive and organic materials and gases.
 - 5) Avoid direct exposure to sunlight and rain .
 - 6) Keep the batteries at least two meters away from heat sources (such as a radiator) .
 - 7) Avoid exposure to intensive infrared radiation.
 - If the PACK has not been used for more than six months, it needs to be charged. The procedure is as follows:
 - 1) Identify the PACK that needs charging;
 - 2) Refer to the quick installation guidance to install the PACK and complete the electrical connection.
- Ensure the PACK is powered off before performing any operations.
- 3) Set the power system as "CC≤25A, CV=55.8V" , activate the PACK and start recharging.
 - 4) Recharge until LED2 flicks.
 - 5) After the battery is charged, leave circuit open for five minutes before you check the voltage. If the voltage is greater than or equals to 52V, the recharge is successful.

3.2 Transportation Requirements

- The PACK passes the certifications of UN38.3 (Section 38.3 of the sixth Revised Edition of the Recommendations on the Transport of Dangerous Goods: Manual of Tests and Criteria) and SN/T 0370.2-2009 (Part 2: Performance Test of the Rules for the Inspection of Packaging for Exporting Dangerous Goods). The PACK belongs to Class 9 dangerous goods.
- The battery pack shall not be transported with other inflammable, explosive or toxic materials.
 - Ensure that the original package and label are intact and identifiable.
 - Avoid direct exposure to sunlight, rain, condensing water caused by temperature difference and mechanical damages.
 - There will be a drop in capacity during transportation and storage.
 - Transportation temperature is between -20°C to 45°C, relative humidity: 5%~95%RH.

Installation 4

 <p>WARNING Avertissement</p>	<ul style="list-style-type: none"> ➢ Read through the Guidance before installation to understand product information and safety cautions/ Assurez-vous de lire le guide avant l'installation afin de comprendre les informations sur le produit et les précautions de sécurité; ➢ Only qualified and well-trained technicians who fully understand the whole photovoltaic system, grid network, battery system, working principle and national/local standards are allowed to perform operations on the battery/ Les opérateurs doivent être des techniciens bien formés et bien comprendre l'ensemble du système photovoltaïque, le réseau électrique, le principe de fonctionnement et les normes régionales nationales; ➢ Installers must use insulating tools and wear safety equipment/ Les installateurs doivent utiliser des outils isolants et porter des équipements de sécurité; ➢ Device damages caused by failure to comply with storage, transportation, installation and use requirements specified in the Guidance are not covered under any Warranty/ Les dommages à l'appareil causés par le non-respect des exigences de stockage, de transport, d'installation et d'utilisation spécifiées dans le guide ne sont pas couverts par la garantie. ➢ The PACK can only be installed indoors. Regarding indoor installation, please do not install it in the bedroom, living room, kitchen, etc./ Le PACK ne peut être installé qu'en intérieur. En ce qui concerne l'installation à l'intérieur, veuillez ne pas l'installer dans la chambre, le salon, la cuisine, etc. ➢ Different types of batteries are not recommended to be mixed and used in parallel/ Il est déconseillé de mélanger et d'utiliser différents types de batteries en parallèle. ➢ The battery system cannot be installed, disassembled, and maintained when it has been powered on. ➢ Please choose to use with isolated PCS.
---	---

4.1 Installation environment

The ambient temperature for the installation of the battery system shall be above 0°C, below 50°C, and the humidity shall be between 5% and 95%.

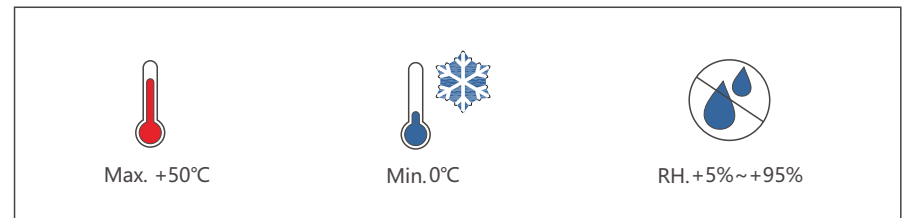

Fig 4.1: Installation environment requirements

4.2 Basic installation requirements

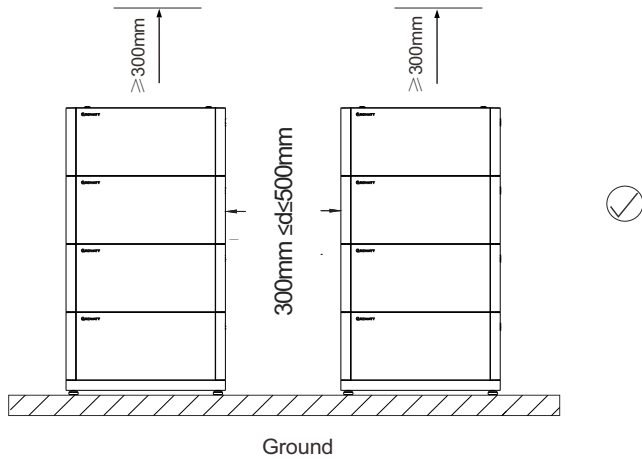
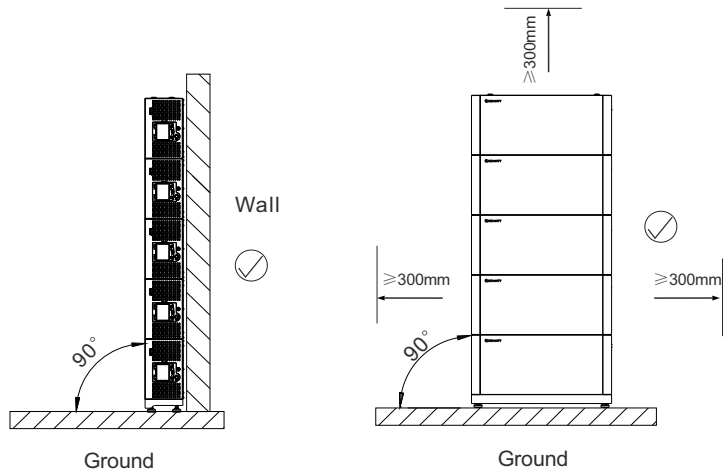

Fig 4.2: Floor-mounted installation



WARNING

Do not turn the PACK upside down, and ensure that the floor is level.

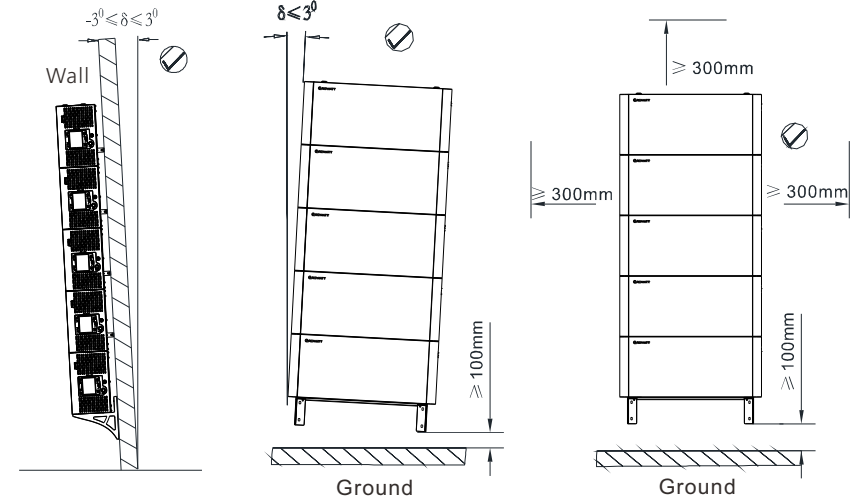

Fig 4.3: Wall-mounted Installation

Note:

The number of battery modules in wall-mounted installation should not exceed five. Ensure that load capacity of the wall exceeds 280kg.

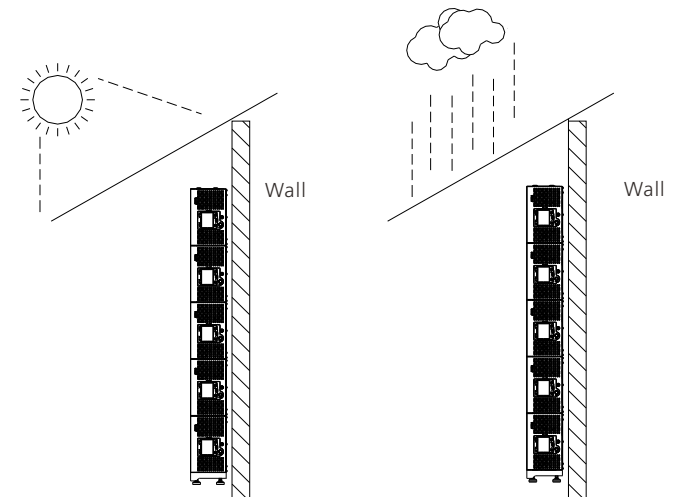

Fig 4.4: Outdoor installation









WARNING

About outdoor installation, install an awning to avoid direct exposure to the sunlight and rain.

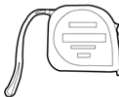
4.3 Installation tools

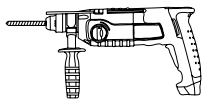
The following tools are required to install the PACK:

		
5mm Allen key	Screw Driver	Wrench
		
Measuring tape	Multimeter	Impact drill
		
Marker		

It is recommended to wear the following safety gear when handling the PACK.

		
Insulated Gloves	Safety Goggles	Safety Shoes

4.4 Check

4.4.1 Pre-installation Check

Check the package	Check the PACK package before unpack it. If any damage is found, do not unpack the Package and contact your distributor.
Check the power	Check and confirm the PACK is powered off before installation.
Check deliverables	Check that the deliverables are intact and complete according to the packing list. If any item is missing or damaged, contact your distributor.

4.4.2 Check the Packing List

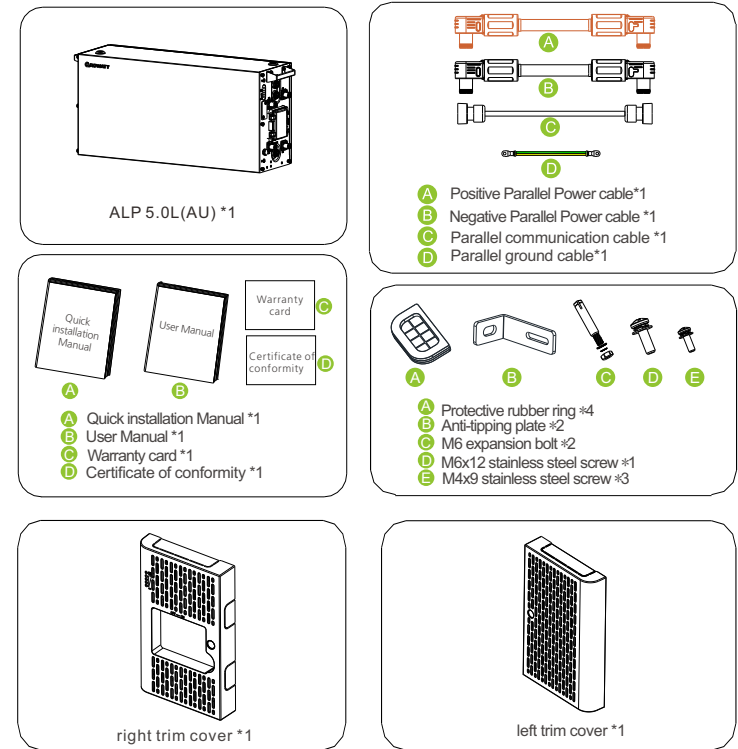

Fig 4.5: ALP 5.0L packing list

4.4.3 Check the accessories

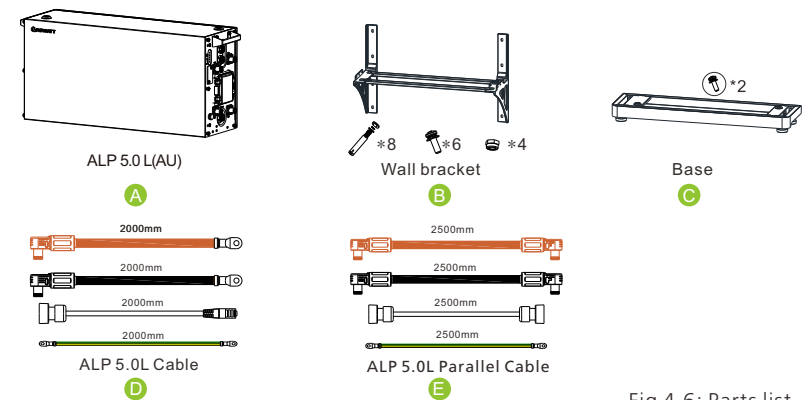



Fig 4.6: Parts list

Installation Method	Compound Mode
Standard wall-mounted installation	$A*N+B+D$
Standard floor-mounted installation	$A*N+C+D$
Wall-mounted battery system stacked in two lines	$A*N+B*2+D+E$
Floor-mounted battery system stacked in two lines	$A*N+C*2+D+E$

Note: "N" stands for the number of batteries.

4.5 Installation

4.5.1 Floor-mounted Installation

 WARNING	<ul style="list-style-type: none"> ➤ The installation base is required while installing the battery system ➤ A maximum of 5 battery packs can be stacked. If there are more than 5 of them, please install them in two lines. ➤ Please make sure the ground is level.
---	--

Hole dimensions (unit: mm)

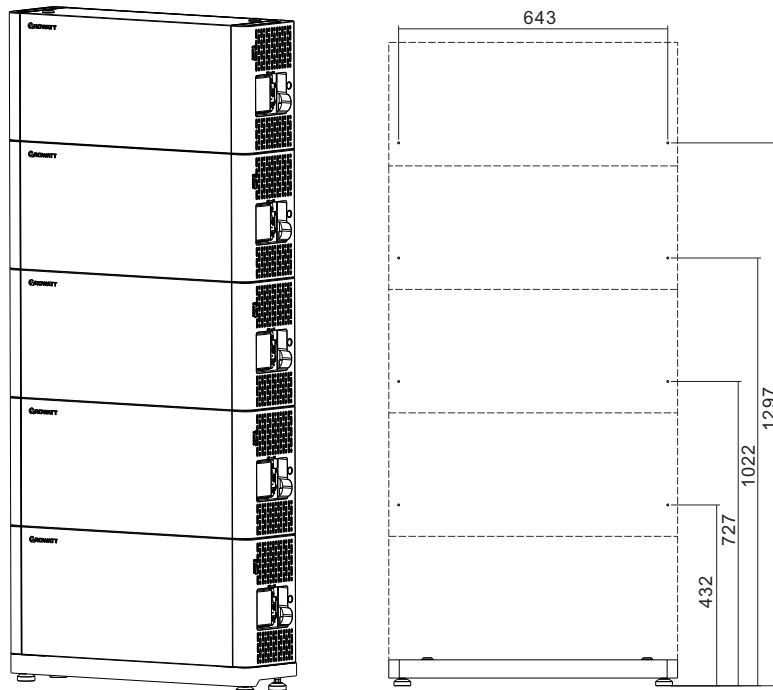

Figure 4.7: Mounting Hole Dimensions

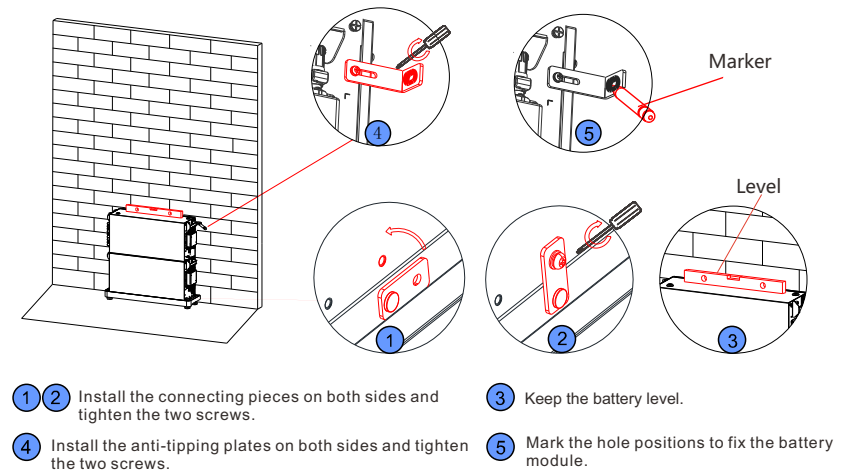

Figure 4.8: Installing the base

Step1: Install the connecting pieces on both sides of the base and tighten the two screws. Place the second battery on the base and keep the module level. Install the anti-tipping plates on both sides and tighten the two screws. Mark the hole positions for the battery.

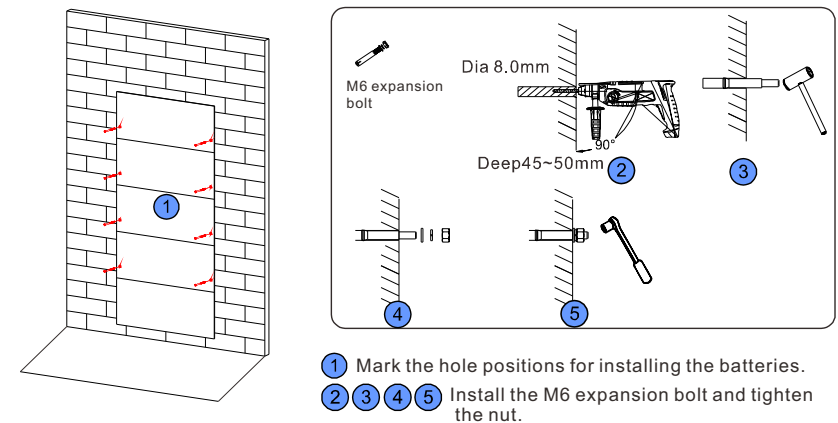

Figure 4.9: Installing expansion bolts

Step 2: Move away the battery. Determine the hole positions for mounting the remaining batteries according to the dimensions shown in Figure 4.7, and mark the hole positions using a marker.
 Drill holes using the alloy drills with a diameter of 8mm (the hole depth: 45mm to 50mm).
 Install the M6 expansion bolts.

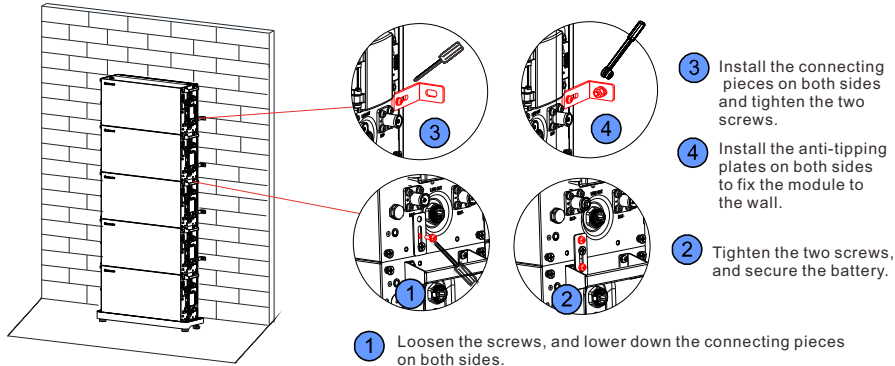

Figure 4.10: Installing the batteries

Step 3: Install the battery modules, ensuring that there are no more than 5 of them. Loosen the screws, lower down the connecting pieces and then tighten the two screws to secure the battery module. Install the connecting pieces on both sides and tighten the two screws. Install the anti-tipping plates on both sides to fix the modules to the wall.

4.5.2 Wall-mounted Installation

Hole dimensions (unit: mm)

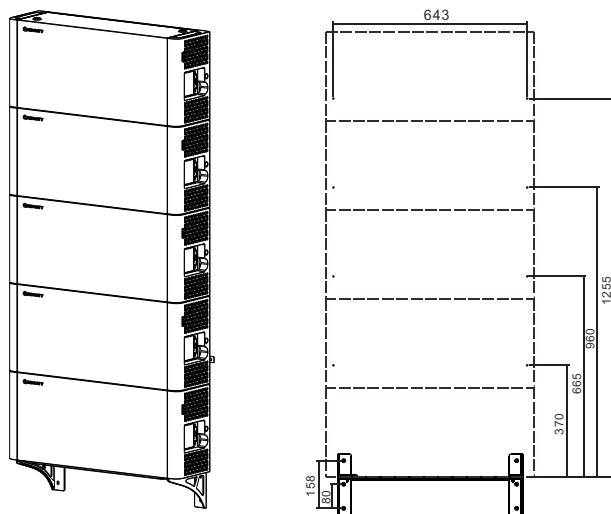

Figure 4.11: Mounting Hole Dimensions

 WARNING	<ul style="list-style-type: none"> ➤ The wall bracket is required while installing the battery system ➤ A maximum of 5 battery packs can be stacked, if there are more than 5 of them, please install them in two lines. ➤ Please make sure the ground is floor.
--------------------	---

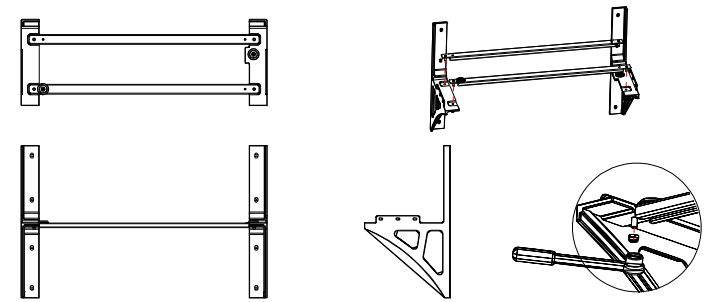

Figure 4.12: Install the wall bracket

Step1: Install the wall bracket

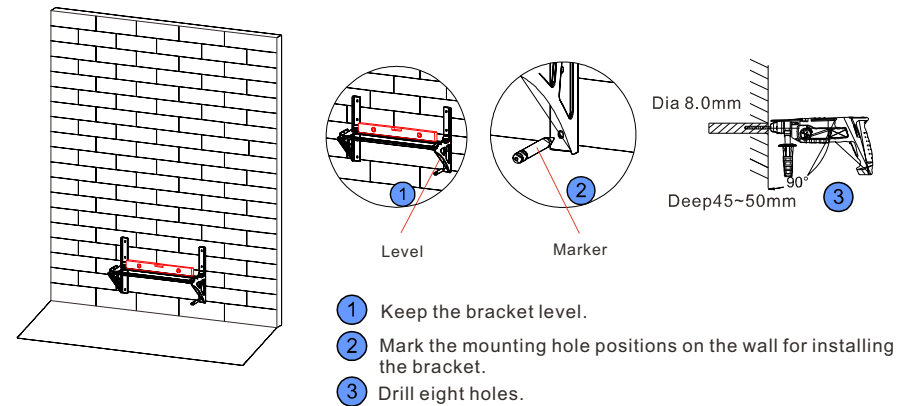

Figure 4.13: Determine the hole positions for installing the wall bracket

Step2: Level the mounting holes using a level, and mark the hole positions for installing the wall bracket using a marker. Drill 8 holes (alloy drill diameter: 8mm; hole depth: 45mm to 50mm).

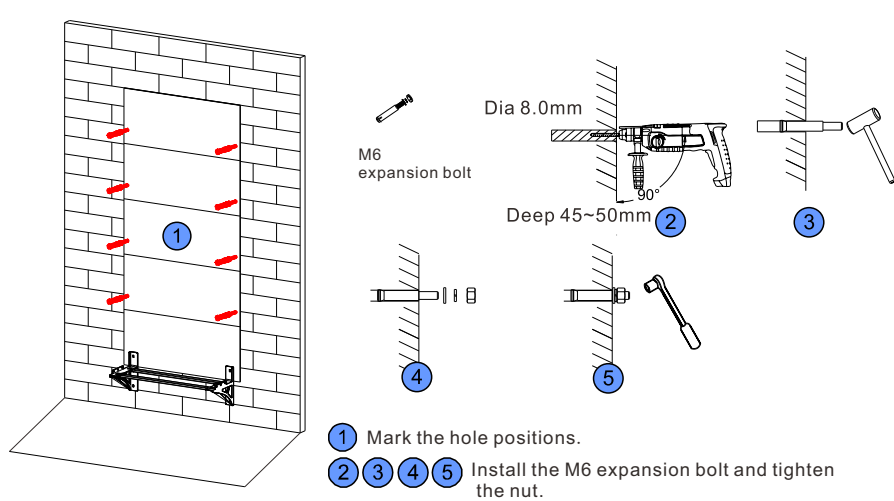

Figure 4.14: Install expansion bolts

Step 3: Fix the wall bracket on the wall. Determine the hole positions for mounting the remaining batteries according to the dimensions shown in Figure 4.11, mark the hole positions using a marker. Drill holes using the alloy drills with a diameter of 8mm (the hole depth: 45mm to 50mm). Install the M6 expansion bolts.

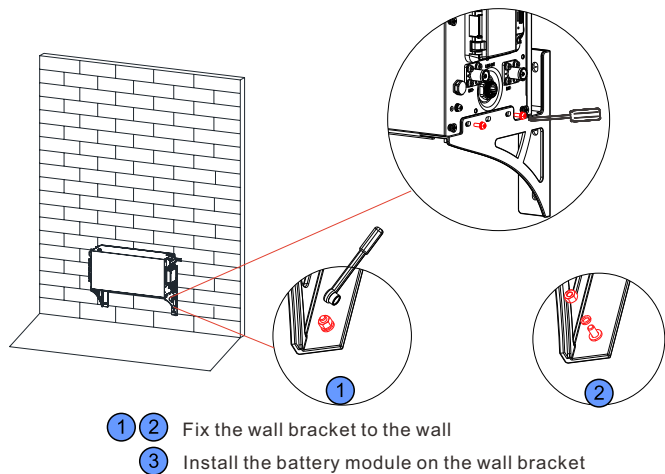

Figure 4.15: Install the bracket and the battery module

Step 4: Fix the wall bracket on the wall and tighten the fixing screws. Place the first battery on the wall bracket. Install the anti-tipping plates on both sides and tighten the two screws.

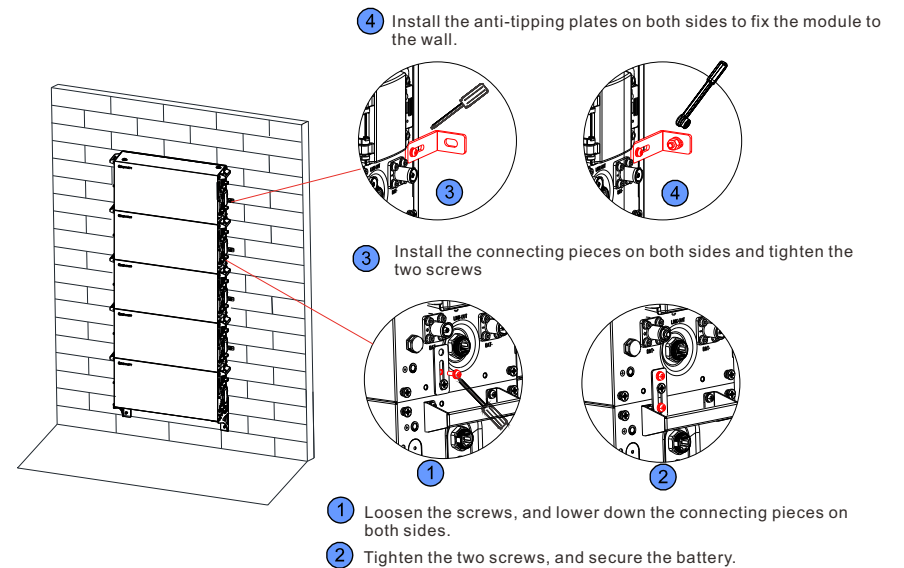

Figure 4.16: Install the remaining the batteries

Step 5: Install the battery modules, ensuring that there are no more than 5 of them. Loosen the screws, lower down the connecting pieces and then tighten the two screws to secure the battery module. Install the connecting pieces on both sides and tighten the two screws. Install the anti-tipping plates on both sides to fix the modules to the wall.

4.5.2 Electrical Connection



WARNING

- Do not forget to wear ESD wrist strap, safety gloves and goggles.
- It is recommended that the power cable and communication cable between the battery and the PCS should not exceed 2 meters.
- Don't forget to install the ground wire, the installation torque of the ground wire is 2N·M.

4.5.2.1 Communication interface definition

Item	Picture of RJ45 Connector	Serial no.	Definition
PCS		1	/
		2	/
		3	GND_COM
		4	CAN_H
		5	CAN_L
		6	GND_COM
		7	WAKE-
		8	WAKE+

4.5.2.2 Communication terminal

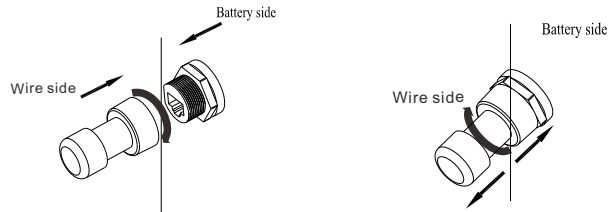

4.5.2.3 Power terminal

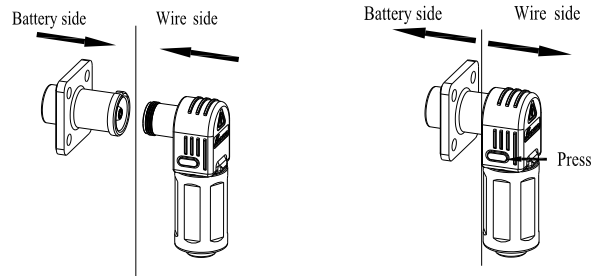

Press the position indicated in the figure above before disconnecting the power terminal.

4.5.2.4 Install the Trim Cover

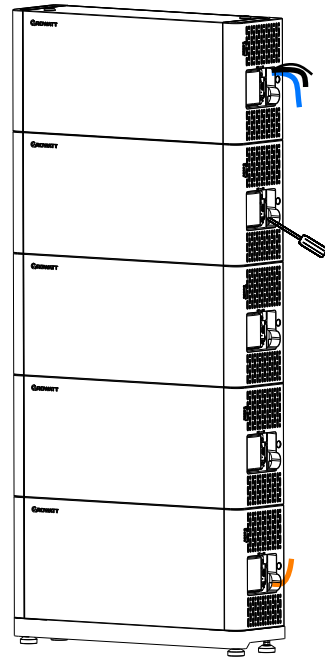
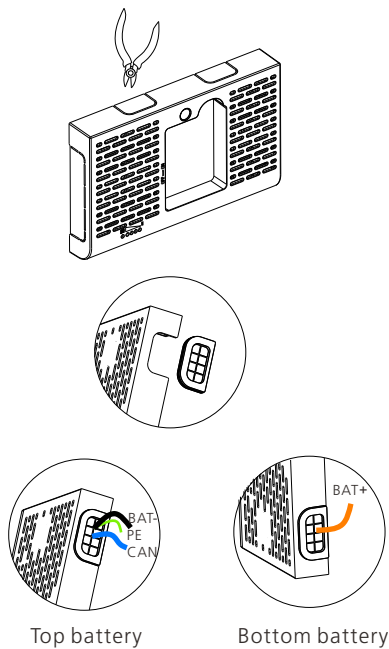

4.5.2.5 Single-column wiring

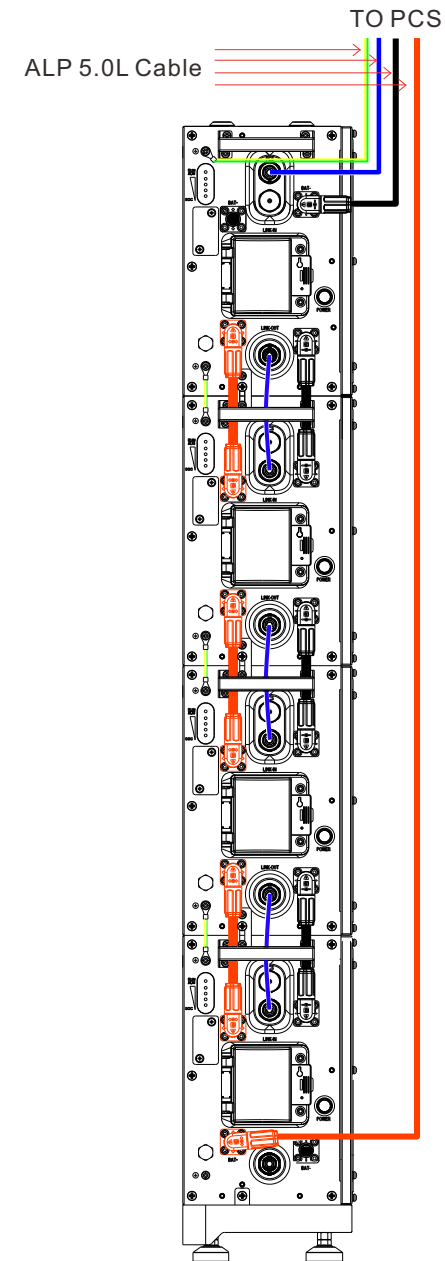

Note:

1. The battery is not allowed to be installed in the running state, and all the RUN lights of battery modules should be off before installation.
2. To ensure system security, do not forget to install the ground wire.
3. For the power cables connected to PCS, the positive power cable is drawn from the top battery module, and the negative power cable is drawn from the bottom battery module.

4.5.2.3 Two-column wiring

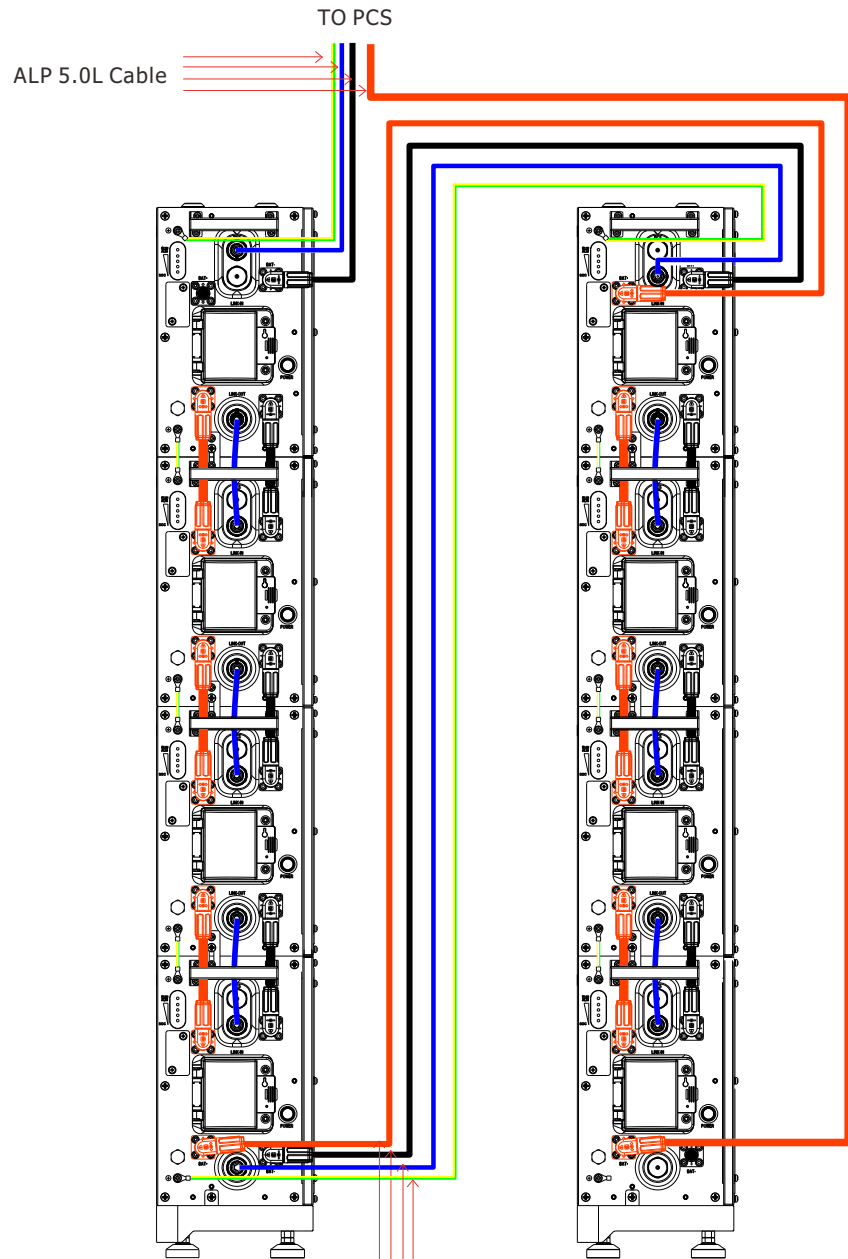

ALP 5.0L Parallel cable

Power on and off the Battery System



WARNING

- Personnel who install and operate the Battery System must receive thorough training and possess the local national required qualifications before operation. Only qualified professionals and trained personnel are allowed to install, operate and maintain the equipment.
- Please stand on dry insulating objects and do not wear conductive material such as watches and necklace during operation. Insulated tools should be used.
- Avoid contact with any parts with electric potential difference.
- Hang the warning sign: Do not touch. Authorized personnel only.
- If any abnormality is found when energizing the equipment, power off the PACK immediately. After solving the problem, turn on the switches again.
- Make sure the inverter is turned off before checking the PACK.

5.1 Power On

When multiple batteries are connected in parallel or multiple clusters of batteries are connected in parallel, press one of the battery power buttons and all the batteries connected in parallel can be turned on (After that, turn on all battery breakers).

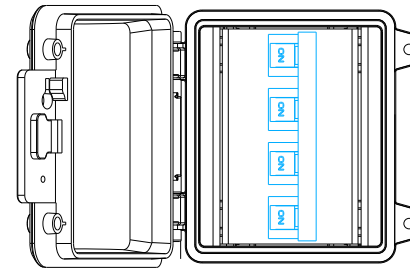

1. Switch the circuit breaker to the "On" position.
2. Press POWER button for 3 seconds. Observe the LED indicator on the panel.
3. The battery LED indicator lights up to indicate that the battery has been turned on.

Power on the PACK by pressing the power button (t>3S)		
Serial	Procedures	Acceptance criteria
1	Connect the battery and PCS	Make sure the wiring harnesses are well connected
2	Switch on the breaker of the PACK	Make sure the breaker is ON
3	Press the POWER button for three to five seconds. Observe the LED indication on panel.	1. If both RUN/ALM and SOC lights are on normally, PACK is powered on successfully. 2. If RUN/ALM light turns red, there is a fault. Do not restart the equipment until the fault is rectified.

Maintenance Guide 6

Power on the PACK by PCS		
1	Connect the battery and PCS	Make sure the wiring harnesses are well connected
2	Switch on the breaker of the PACK	Make sure the breaker is ON
3	Power on the PCS. PCS outputs a wake up signal of 5V or an output main circuit voltage signal of 46-58V	1.If both RUN/ALM and SOC lights turn on normal, PACK powers on successfully. 2.If RUN/ALM light turns red, it indicates a fault and you should solve it before power on the PACK again.

5.2 Power off

Press the power button to turn off the PACK and the five LED lights will flicker three times. If multiple packs are connected in parallel, turning off one of the PACKs will shut down the whole battery system.

6.1 Preparation

- Prepare tools including safety gloves, a cross-head screwdriver and a socket wrench.
 - Turn on and turn off the PACK.
 1. If the PACK is powered off, press and hold the power button for 3-5 seconds to turn it on.
 2. If the PACK is powered on, press the power button once to turn it off.
- Before maintaining the battery, turn off the breaker and press the power button once again to make sure the PACK is power-off. Follow the installation and wire connection procedures specified above. Ensure wires are properly connected before turning the breaker on. After that, turn on the breaker and press the power button on one of the PACKs for 3-5 seconds to check if the system operates normally.
3. When installing or maintaining the equipment, it is recommended that the battery SOC be at 35% ~45%.

6.2 PACK Replacement

- Wear safety gloves.
- Switch off the breaker and power off the PACK.
- Unscrew the safety screws under the power supply, and disconnect the power lines and the CAN communication cables of the PACK.
- Remove the safety part at the left end of the battery and turn the PACK upward.
- Put the PACK into the packing box according to the repair procedure and transport the PACK to the designated repair site.
- Install new PACK based on procedure specified in Section 4.

6.3 System Failure Information List and Troubleshooting Suggestions

Error Indication	Error description	Error cause	Suggested actions
ALM	Discharge under voltage protection	Single cell voltage is below the threshold for under-voltage protection	1. There is a risk of over-discharge. 2. User should stop discharging and arrange recharge
* (ALM Light Flickers)	Charge over voltage protection	Single cell voltage exceeds threshold for protection	1. There is no safety threat. 2. User should stop charging. Wait until the alarm disappears.
	External CAN Communication failure	Communication loss between PCS and PACK	1. There is no safety threat and user should stop using battery. 2. Check if PCS and battery communication terminal is well connected. 3. If the alarm persists after the communication wire is confirmed to be well-connected, user should contact the installer to repair the battery.

Technical Specifications 7

* (ALM Light Flickers)	Interior CAN Communication failure	Communication loss between two batteries	Check Can connection between two batteries, CAN connection between Linkin and Linkout.
	Parallel connection failure protection	Communication failure between two parallel connected PACKs	Check Can connection between two batteries, CAN connection between Battery and PCS.
* (ALM Light on)	Discharge short circuit	External short circuit of PACK	1. There is safety risk and user should stop using the battery. 2. User should contact installer to repair PCS and battery.
	Precharge short circuit		
	Precharge overtime		
	Type inconsistency of PACK	The pack type is different	1. There is safety risk and user should stop using the battery 2. User should contact installer to use the same PACK in Parallel.
Main circuit fault	BMS main power circuit failure	1. There is safety risk and user should stop using the battery. 2. User should contact installer to repair battery.	

6.4 About mixing old and new batteries in parallel

Please ensure batteries in parallel connection are from the same batch, same model and same manufacturer. Do not mix an old battery with a new battery. Batteries undergone less than 300 cycles are defined as new batteries. Ensure that the duration between the installation of the newly added battery and the existing battery is within one year, and the newly added battery must be within the shelf life of 6 months.

Functional parameters of ALP 5.0L Energy Storage System are shown as below:

No.	Items	Specifications	
		1	2
1	Number of parallel battery systems	1	2
2	Battery Model	ALP 5.0L-E1	ALP 10.0L-E1
3	Nominal Capacity/Energy	100Ah/5.0kWh	200Ah/10.0kWh
4	Rated Capacity/Energy	90Ah/4.6kWh	180Ah/9.2kWh
5	Rated Voltage	51.2V	
6	Operating Voltage	46.4 - 57.6V	
7	Rated Charging/discharging current	75A	100A
8	Max Charging/discharging current	90A	125A
9	Over current protection	90A	125A
10	Rated Charging/discharging power	3.7kW	5kW
11	Max Charging/discharging power	4.5kW	6.2kW
12	Battery Type	Cobalt Free Lithium Iron Phosphate (LFP)	
13	Operative temperature range	0°C ~ 50°C	
14	Recommended operating temperature	15°C ~ 30°C	
15	Storage conditions	Temperature: -20°C ~ +50°C / 7 days -20°C ~ 40°C / 6 months Humidity: 5% ~ 95%RH Within six months after initial charge	
16	Cooling	Natural cooling	
17	Dimension (W/D/H) (mm)	690*185*295	690*185*590
18	Weight	44kg	88kg
19	Installation	Wall-mounted/Floor-mounted Installation	
20	Ingress protection	IP 66	
21	Cell safety certification	IEC62619/UL1973	
22	PACK certification	IEC 62619/IEC 63056/ IEC 62040/CE/UKCA/CEC/RoHS/UN38.3	
23	Charging batteries	See Appendix II	
24	Communication port	CAN	
25	Battery Designation	IFpP/51/161/119 /[(1P16S)1P]M/0 +50/90	IFpP/51/161/119 /[(1P16S)2P]M/0+ 50/90

No.	Items	Specifications	
1	Number of parallel battery systems	3	4
2	Battery Model	ALP 15.0L-E1	ALP 20.0L-E1
3	Nominal Capacity/Energy	300Ah/15.0kWh	400Ah/20.0kWh
4	Rated Capacity/Energy	270Ah/13.8kWh	360Ah/18.4kWh
5	Rated Voltage	51.2V	
6	Operating Voltage	46.4 - 57.6V	
7	Rated Charging/discharging current	100A	100A
8	Max Charging/discharging current	125A	125A
9	Over current protection	125A	125A
10	Rated Charging/discharging power	5kW	5kW
11	Max Charging/discharging power	6.2kW	6.2kW
12	Battery Type	Cobalt Free Lithium Iron Phosphate (LFP)	
13	Operative temperature range	0°C~50°C	
14	Recommended operating temperature	15°C~30°C	
15	Storage conditions	Temperature: -20°C ~ +50°C/ 7 days -20°C ~ 40°C/6 months Humidity: 5%~95%RH Within six months after initial charge	
16	Cooling	Natural cooling	
17	Dimensions (W/D/H) (mm)	690*185*885	690*185*1180
18	Weight	132kg	176kg
19	Installation	Wall-mounted/Floor-mounted Installation	
20	Ingress protection	IP 66	
21	Cell safety certification	IEC62619/UL1973	
22	PACK certification	IEC 62619/IEC 63056/ IEC 62040/CE/UKCA/CEC/RoHS/UN38.3	
23	Charging batteries	See Appendix II	
24	Communication port	CAN	
25	Battery Designation	IFpP/51/161/119 /[(1P16S)3P]M/0 +50/90	IFpP/51/161/119/ [(1P16S)4P]M/0+ 50/90

No.	Items	Specifications	
1	Number of parallel battery systems	5	6
2	Battery Model	ALP 25.0L-E1	ALP 30.0L-E1
3	Nominal Capacity/Energy	500Ah/25.0kWh	600Ah/30.0kWh
4	Rated Capacity/Energy	450Ah/23.0kWh	540Ah/27.6kWh
5	Rated Voltage	51.2V	
6	Operating Voltage	46.4 - 57.6V	
7	Rated Charging/discharging current	100A	100A
8	Max Charging/discharging current	125A	125A
9	Over current protection	125A	125A
10	Rated Charging/discharging power	5kW	5kW
11	Max Charging/discharging power	6.2kW	6.2kW
12	Battery Type	Cobalt Free Lithium Iron Phosphate (LFP)	
13	Operative temperature range	0°C~50°C	
14	Recommended operating temperature	15°C~30°C	
15	Storage conditions	Temperature: -20°C ~ +50°C/ 7 days -20°C ~ 40°C/6 months Humidity: 5%~95%RH Within six months after initial charge	
16	Cooling	Natural cooling	
17	Dimensions (W/D/H) (mm)	690*185*1475	690*185*1770
18	Weight	220kg	264kg
19	Installation	Wall-mounted/Floor-mounted Installation	
20	Ingress protection	IP 66	
21	Cell safety certification	IEC62619/UL1973	
22	PACK certification	IEC 62619/IEC 63056/ IEC 62040/CE/UKCA/CEC/RoHS/UN38.3	
23	Charging batteries	See Appendix II	
24	Communication port	CAN	
25	Battery Designation	IFpP/51/161/119 /[(1P16S)5P]M/0 +50/90	IFpP/51/161/119/ [(1P16S)6P]M/0+ 50/90

No.	Items	Specifications	
1	Number of parallel battery systems	7	8
2	Battery Model	ALP 35.0L-E1	ALP 40.0L-E1
3	Nominal Capacity/Energy	700Ah/35.0kWh	800Ah/40.0kWh
4	Rated Capacity/Energy	630Ah/32.2kWh	720Ah/36.8kWh
5	Rated Voltage	51.2V	
6	Operating Voltage	46.4 - 57.6V	
7	Rated Charging/discharging current	100A	100A
8	Max Charging/discharging current	125A	125A
9	Over current protection	125A	125A
10	Rated Charging/discharging power	5kW	5kW
11	Max Charging/discharging power	6.2kW	6.2kW
12	Battery Type	Cobalt Free Lithium Iron Phosphate (LFP)	
13	Operative temperature range	0°C~50°C	
14	Recommended operating temperature	15°C~30°C	
15	Storage conditions	Temperature: -20°C ~ +50°C/ 7 days -20°C ~ 40°C/6 months Humidity: 5%~95%RH Within six months after initial charge	
16	Cooling	Natural cooling	
17	Dimensions (W/D/H) (mm)	690*185*2065	690*185*2360
18	Weight	308kg	352kg
19	Installation	Wall-mounted/Floor-mounted Installation	
20	Ingress protection	IP 66	
21	Cell safety certification	IEC62619/UL1973	
22	PACK certification	IEC 62619/IEC 63056/ IEC 62040/CE/UKCA/CEC/RoHS/UN38.3	
23	Charging batteries	See Appendix II	
24	Communication port	CAN	
25	Battery Designation	IFpP/51/161/119 /[(1P16S)7P]M/0 +50/90	IFpP/51/161/119/ [(1P16S)8P]M/0+ 50/90

LED indication Control Mechanism

Status	Items	LED light definition					RUN/ALM	Remark
		SOC indication						
		LED1	LED2	LED3	LED4	LED5		
Charge SOC	0%-25%	✱(t=1S)				●	RUN/ALM light on and one SOC light flickers	
	26%-50%	●	✱(t=1S)			●		
	51%-75%	●	●	✱(t=1S)		●		
	76%-99%	●	●	●	✱(t=1S)	●		
	100%	●	●	●	●	●		
Discharge SOC	100%-76%	●	●	●	●	●	RUN/ALM light on and one SOC light flickers	
	75%-51%	●	●	●		●		
	50%-26%	●	●			●		
Idle	25%-0%	●				●	RUN/ALM light on and one SOC light flickers	
	100%-76%	●	●	●	●	●		
	75%-51%	●	●	●		●		
	50%-26%	●	●			●		
Parallel connection	Parallel connection is successful						●	RUN/ALM light flickering green
Protection	Cell charge overvoltage alarm	SOC indicates current remaining capacity					✱(t=1S)	RUN/ALM light flickering green
	Cell charge overvoltage protection						✱(t=1S)	RUN/ALM light flickering green
	PACK charge overvoltage alarm						✱(t=1S)	RUN/ALM light flickering green
	PACK charge overvoltage protection						✱(t=1S)	RUN/ALM light flickering green
	Over charge and over discharge alarm						✱(t=1S)	RUN/ALM light flickering green

Protection	Over charge and over discharge protection	SOC indicates current remaining capacity	🌟(t=1S)	RUN/ALM light flickering green
	Charging current limit does failure		🌟(t=1S)	RUN/ALM light flickering green
	Charge and discharge high temperature alarm		🌟(t=1S)	RUN/ALM light flickering green
	Charge and discharge high temperature protection		🌟(t=1S)	RUN/ALM light flickering green
	Charge and discharge low temperature alarm		🌟(t=1S)	RUN/ALM light flickering green
	Charge and discharge low temperature protection		🌟(t=1S)	RUN/ALM light flickering green
	Cell discharge undervoltage alarm		🌟(t=1S)	RUN/ALM light flickering green
	Cell discharge undervoltage protection		🌟(t=1S)	RUN/ALM light flickering green
	PACK discharge undervoltage alarm		🌟(t=1S)	RUN/ALM light flickering green
	PACK discharge undervoltage protection		🌟(t=1S)	RUN/ALM light flickering green
	Charge and discharge Overcurrent hardware protection		🌟(t=1S)	RUN/ALM light flickering green

Protection	Mos high temperature alarm	SOC indicates current remaining capacity	🌟(t=1S)	RUN/ALM light flickering green
	Mos high temperature protection		🌟(t=1S)	RUN/ALM light flickering green
	High temperature environment alarm		🌟(t=1S)	RUN/ALM light flickering green
	High temperature environment protection		🌟(t=1S)	RUN/ALM light flickering green
	Cell Large voltage difference alarm		🌟(t=1S)	RUN/ALM light flickering green
	Cell Large voltage difference protection		🌟(t=1S)	RUN/ALM light flickering green
	difference protection between PACK voltage and module voltage		🌟(t=1S)	RUN/ALM light flickering green
	Parallel connection over charge and over discharge alarm		🌟(t=1S)	RUN/ALM light flickering green
Fault, personnel handling required	Discharge short circuit	SOC indicates current remaining capacity	🔴(t=1S)	RUN/ALM light flickering red
	Precharge short circuit		🔴(t=1S)	RUN/ALM light flickering red
	Precharge overtime		🔴(t=1S)	RUN/ALM light flickering red
	External CAN communication failure		🔴(t=1S)	RUN/ALM light flickering red
	Interior CAN communication failure		🔴(t=1S)	RUN/ALM light flickering red
	Parallel connection failure		🔴(t=1S)	RUN/ALM light flickering red

Fault, personnel handling required	Type inconsistency of PACK	SOC indicates current remaining capacity	✱(t=1S)	RUN/ALM light flickering red
	Batteries failure protection		●	RUN/ALM light steady red
	Voltage sampling anomaly protection		●	RUN/ALM light steady red
	Current sampling fault		●	RUN/ALM light steady red
	Main circuit fault		●	RUN/ALM light steady red

Appendix II

Charging batteries

1) Charge the cells with a constant current of 75A until the highest cell voltage reaches

3.5V.

1) Charge the cells with a constant current of 60A until the highest cell voltage reaches 3.53V.

2) Charge the cells with a constant current of 25A until the highest cell voltage reaches 3.54V.

3) Charge the cells with a constant current of 10A until the highest cell voltage reaches 3.55V.

4) Charge the cells with a constant current of 5A until the highest cell voltage reaches 3.55V.(SOC is 100%)

Shenzhen Growatt New Energy Co., Ltd

4-13/F, Building A, Sino-German (Europe) Industrial Park,
Hangcheng Ave, Bao'an District, Shenzhen, China

T +86 755 2747 1942

E service@ginverter.com

W www.ginverter.com