

BACH KIT

INSTALLATION MAUNAL



WARNING - READ CAREFULLY

While this manual seeks to be as comprehensive as possible, some aspects are not covered due to the different requirements for each installation. We recommend consulting the applicable standards for all installations. These may include:

- AS/NZ 3000
- AS/NZ 4509
- AS/NZ 5033
- AS/NZ 5139

Any installation aspect involving voltages above ELV (120VDC) or groundworks is prescribed electrical work and must be carried out by an accredited electrician.



Risk of Electrical Shock, Burning and Explosion

- Improper installation or failure to follow proper work-site practices can place the installer and user at risk of multiple hazards.
- The installation contains works with multiple voltages that can cause electrical shock.
- Improper installation can cause excessive electrical currents, which may lead to burning.
- Lead-acid batteries can also release hydrogen gas when they are charged, which can create a fire or explosion hazard if it accumulates in an enclosed space.



Risk of Chemical Burn and Poisoning from Battery Electrolyte

- Lead acid batteries contain sulfuric acid, which can cause burns and other injuries if it comes into contact with skin or eyes.
- Risk of respiratory problems from inhaling battery acid fumes.
- Do not open or modify the battery.
- Use correct personal protection equipment, such as rubber gloves, boots and goggles, when handling and installing batteries.



Risk of Injury due to Short Circuit Currents

If a battery bank's output is short-circuited, injury due to heat or eye injury due to arc flash may occur.

When working with the battery bank:

- Connect one wire at a time.
- Use battery caps.
- Use insulated tools.
- Do not wear any conductive items.
- Do not place any tools on the batteries.



Risk of Injury due to the Handling of Heavy Objects

- Components in the installation, such as batteries, are very heavy.
- Get help from a partner or team to lift and move heavy objects.
- Use proper lifting techniques and equipment such as dollies, carts and forklifts.
- Improper handling may lead to back injuries, strains or sprains, slips, trips or falls.

BACH KIT



All wiring and voltages in this kit installation are well under the 120V DC standards for extra-low voltage (ELV). ELV is an electricity supply voltage in a range which carries a very low risk of electrical shock.



Installation of this kit does not require an electrician. However, we recommend seeking help if you are not confident in your ability at any stage.

We are always happy to help guide you through the install, troubleshoot, and answer any questions. You can contact us on 09 218 5533, or info@gridfree.store.

We recommend reading these instructions in full prior to starting your install.

KIT CONTENTS

4x PERC MONO Solar Panel

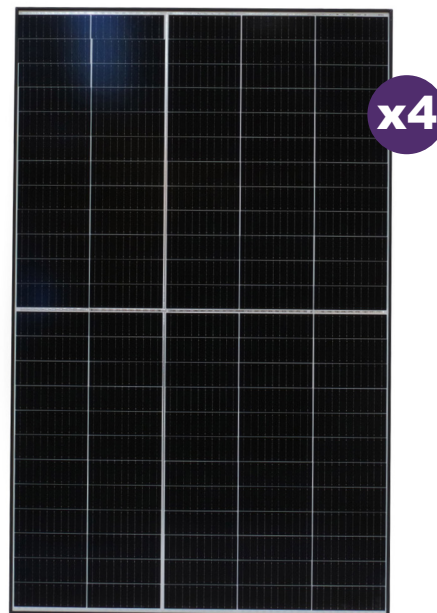

4x 12v200Ah Deep Cycle Gel Battery



1x IPT 3000W 48V Pure Sine Wave Inverter (IPT3000-42)



1x 60A MPPT Charge Controller (6415AN)



1x 32A Solar PV DC Circuit Breaker



1x 63A Charge Controller DC Circuit Breaker



1x 125A Inverter DC Circuit Breaker



1x HT-8 MCB Enclosure



1x 25mm² Cable 3m Pre-Crimped (Red + Black)



2x 25mm² M6 Crimps



1x 16mm² Cable 3m Pre-Crimped (Red + Black)



3x 50mm² 30cm Battery Link Cable



1x 6mm² Solar PV Cable Pair 10m – Pre-Crimped MC4 (Red + Black)



1x MC4 Y-Branch Connector Cable Pair 2.5m



2x PV Inline Fuse



REQUIRED TOOLS

Screwdrivers

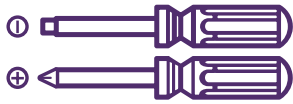

Drill



Wire Strippers

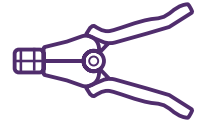

Wire Cutters

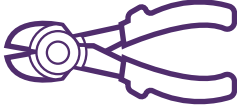

25mm Lug Crimping Tool

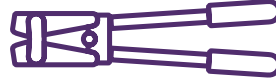

6mm Allen Key



13mm Spanner



Socket Set



SOLAR MOUNT OPTIONS

Ground

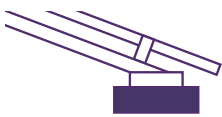

Tilt

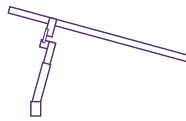

Corrugated



L-Feet



WIRING OVERVIEW

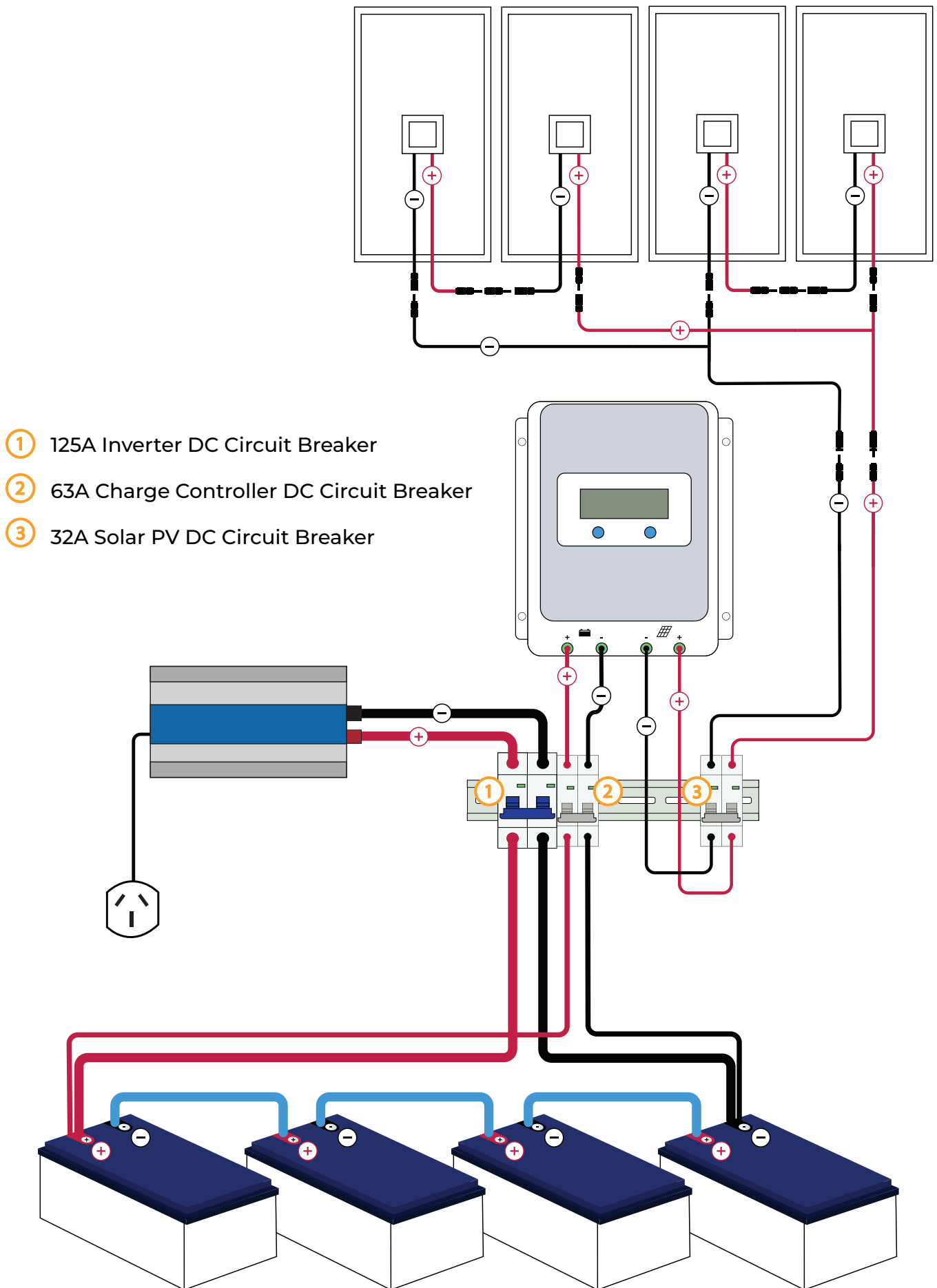

SOLAR PANEL WIRING

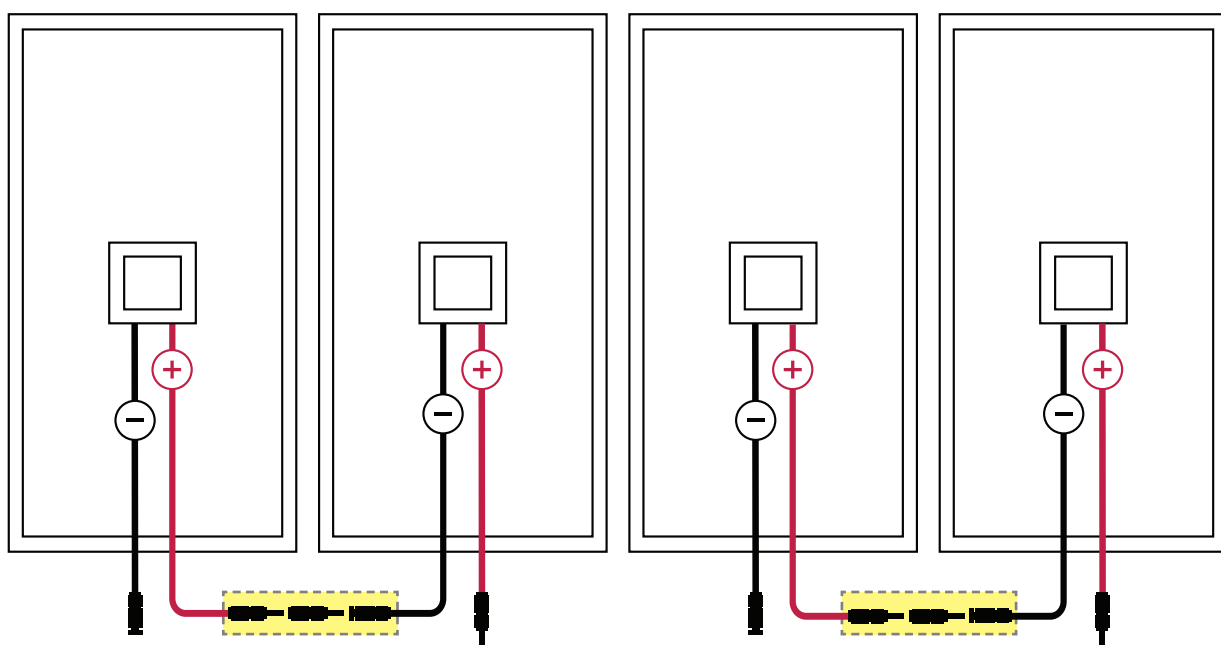
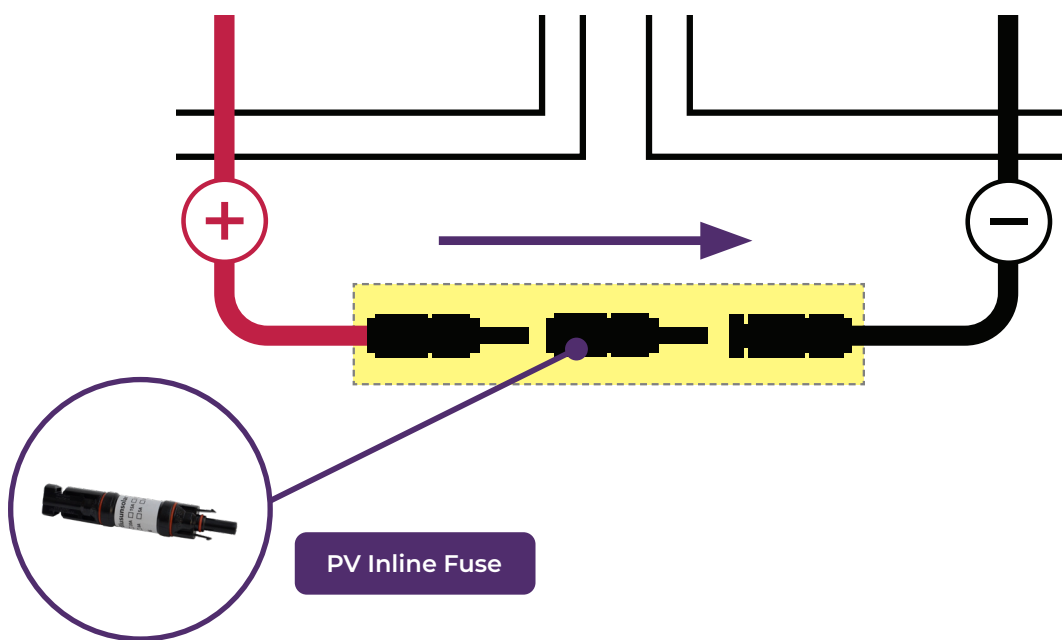

- 1 Start by creating two pairs of panels wired together. Connect the positive terminal of one panel to the inline fuse, then to the negative terminal of the next panel.

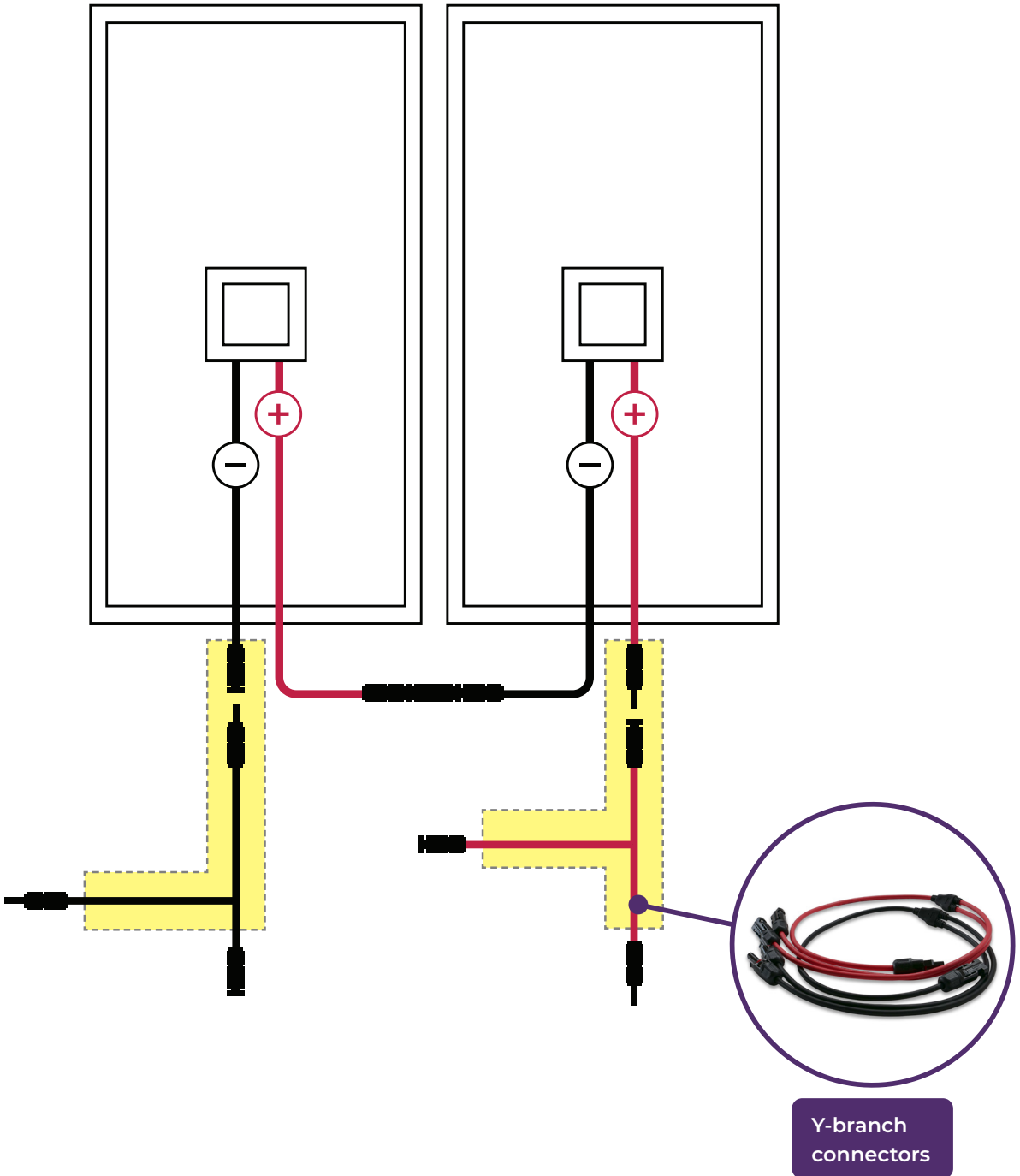

2 Connect the Y-branch connectors to one of the solar panel pairs.

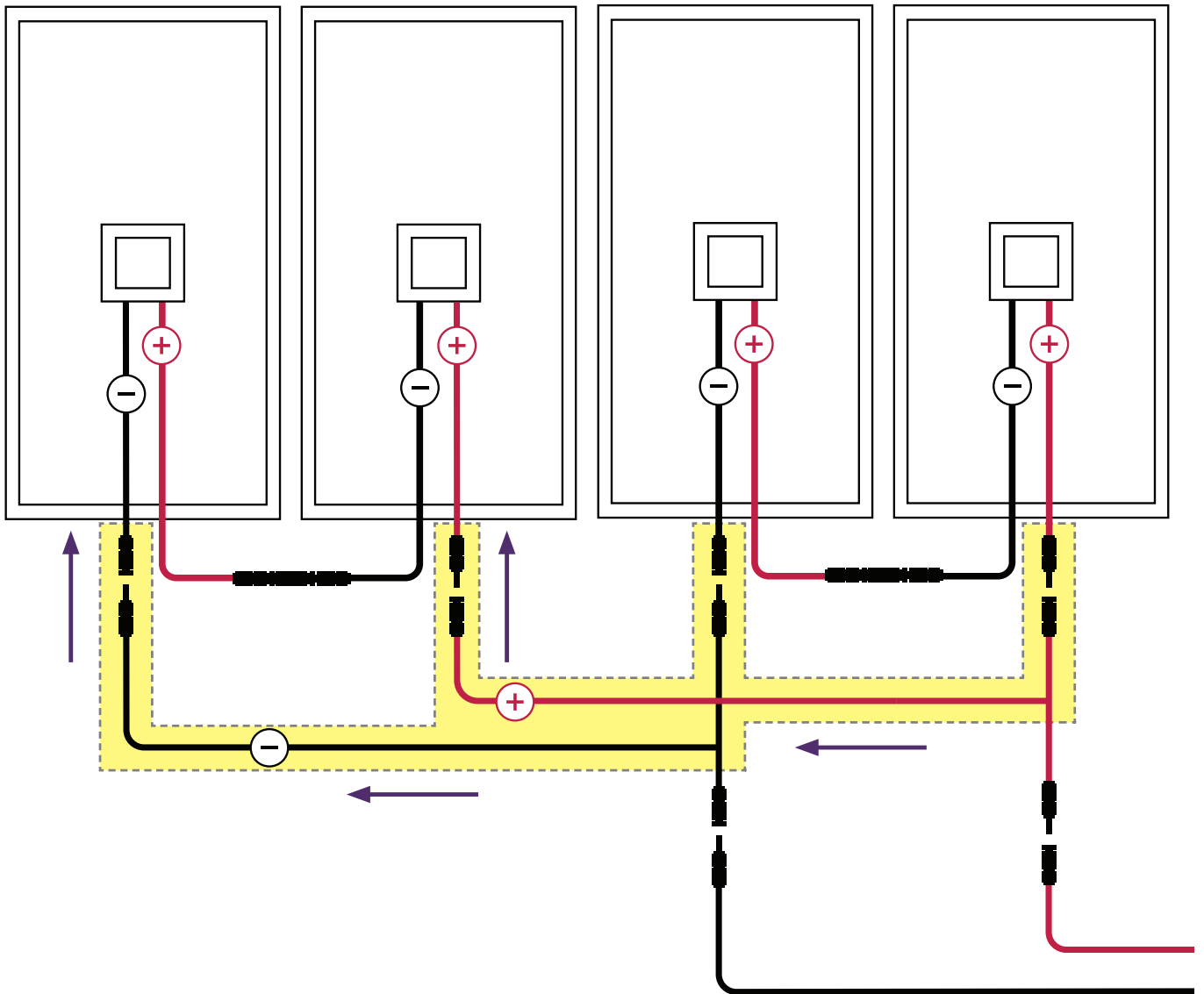

- 3 Connect the other pair of solar panels to the Y-branch connectors, connecting the negative terminals from each pair with the black Y-branch connector, and the positive terminals from each pair with the red.

This creates two outputs from the solar array: one positive (+), one negative (-).

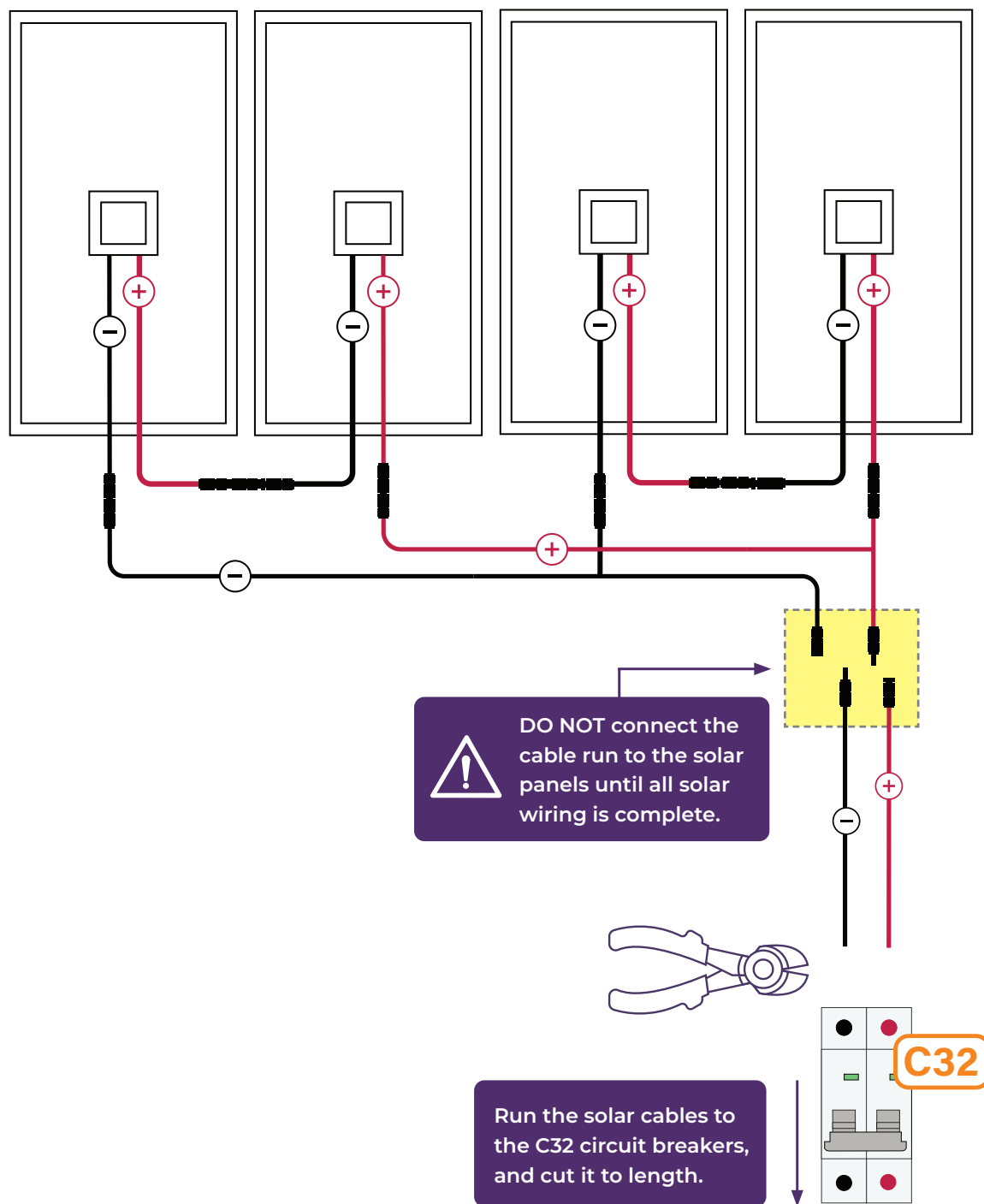

- 4 Run the 6mm² PV solar cables from the solar panels back to the C32 circuit breakers, and cut it to length.



DO NOT connect the cable run to the solar panels as the cables will become live. Wait until all solar wiring is complete

The PV cable must be run inside of a suitable conduit when the cable is run across a roof, floor, or the interior of a building.

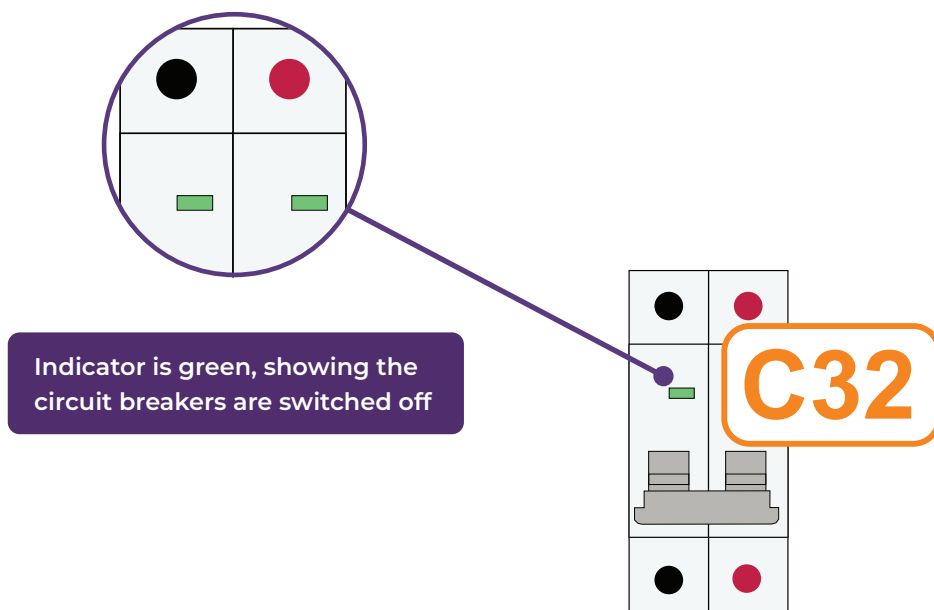

⚠ Ensure the solar cable run is **NOT** connected to the solar panels, and the circuit breakers are switched off (green indicator, switch down)

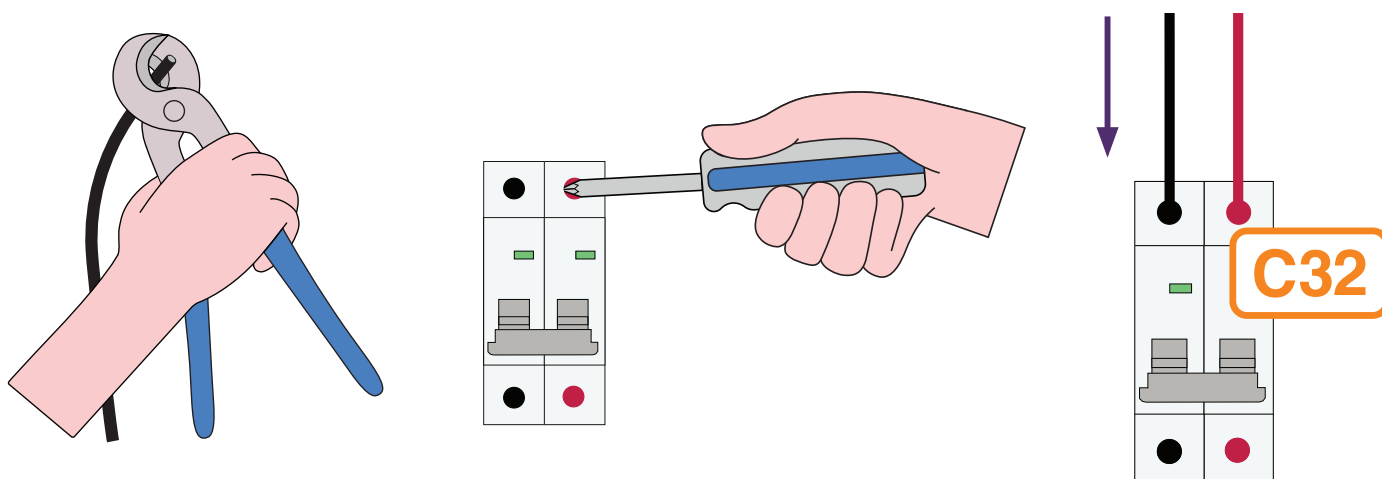

- 5 Use wire strippers to strip the ends of the solar cable, and terminate them in the circuit breaker by inserting the stripped end and tightening the screw clockwise. Make sure the clamp inside the circuit breaker is in contact with the metal conductor, and **NOT** the insulation of the wire.

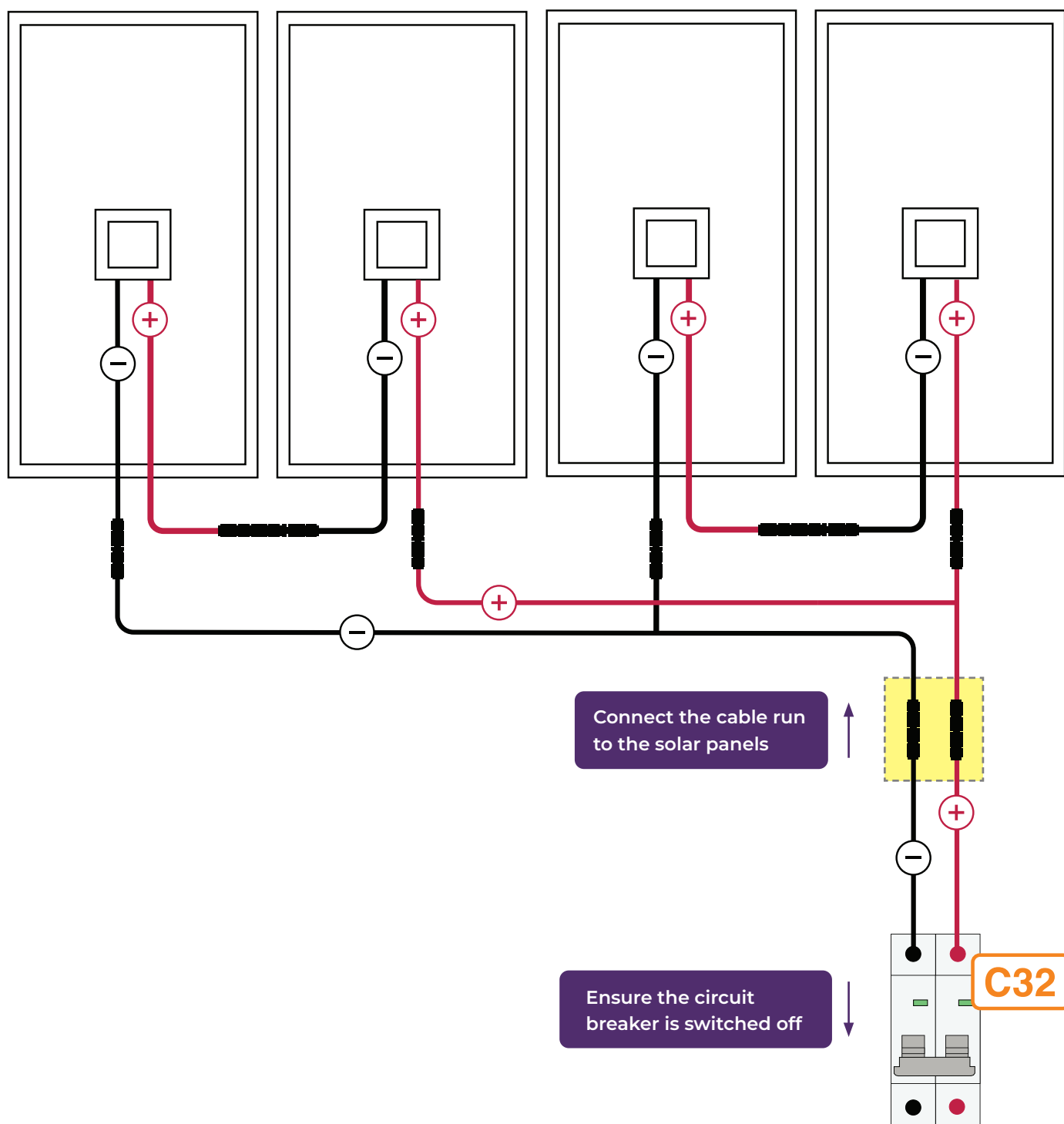

- 6 When the cables have been terminated in the circuit breaker and the circuit breaker is switched off, you can now connect the solar panels to the cable run. The circuit breaker must be switched off when connecting or disconnecting the solar panels from the cable run.

For your safety, **DO NOT** connect or disconnect any solar cables when there is current running through them.

CHARGE CONTROLLER & INVERTER WIRING

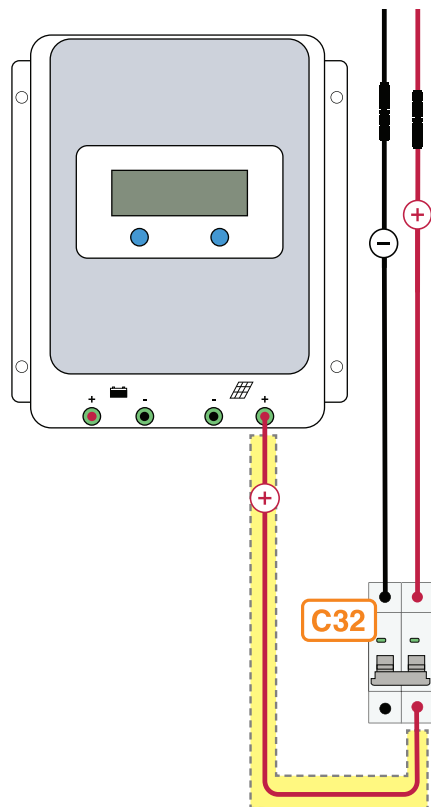

- 1 Wire the positive(+) 6mm² cable from the charge controller to the C32 circuit breaker.

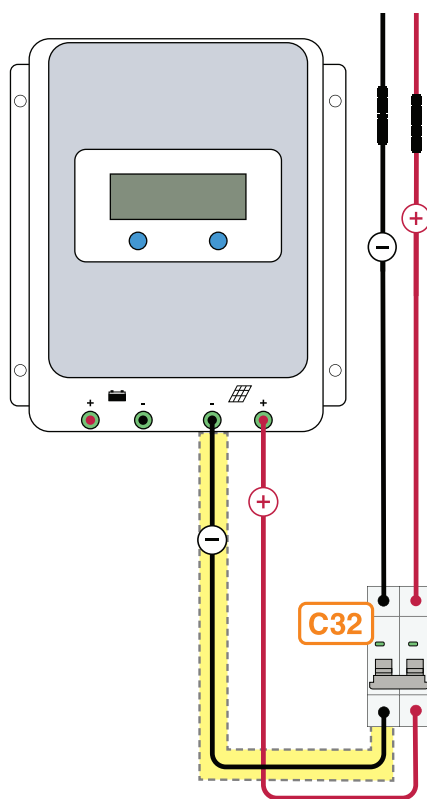

- 2 Wire the negative(-) 6mm² cable from the charge controller to the C32 circuit breaker.

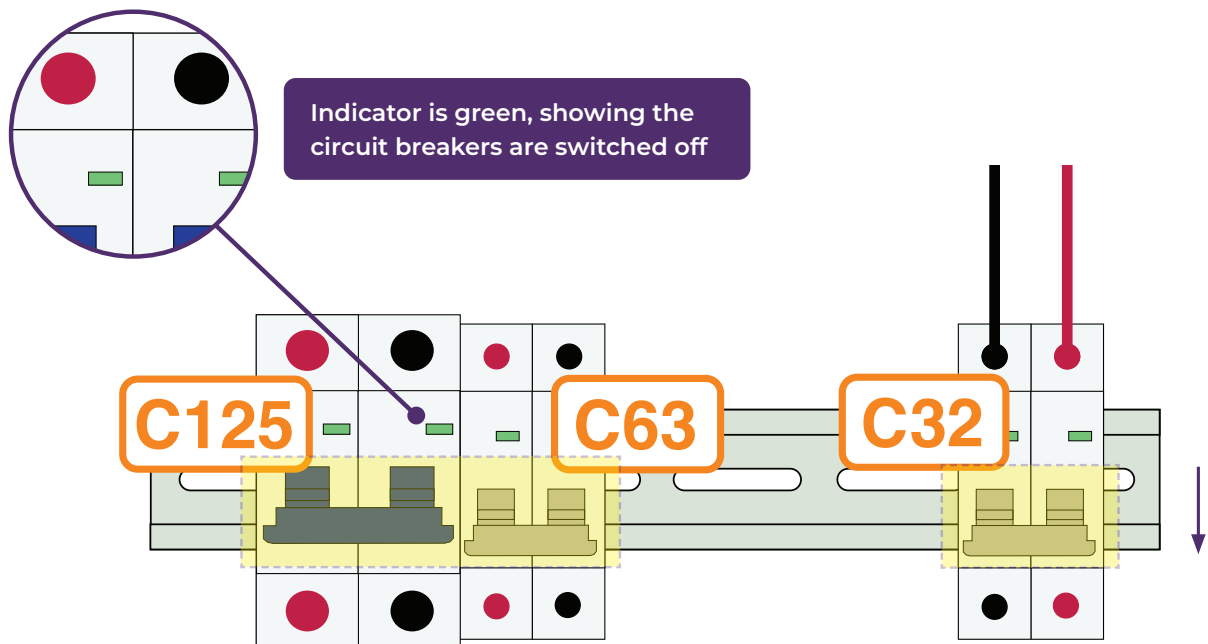

- 3 Ensure all circuit breakers are switched off before wiring (switch down, indicator showing green).

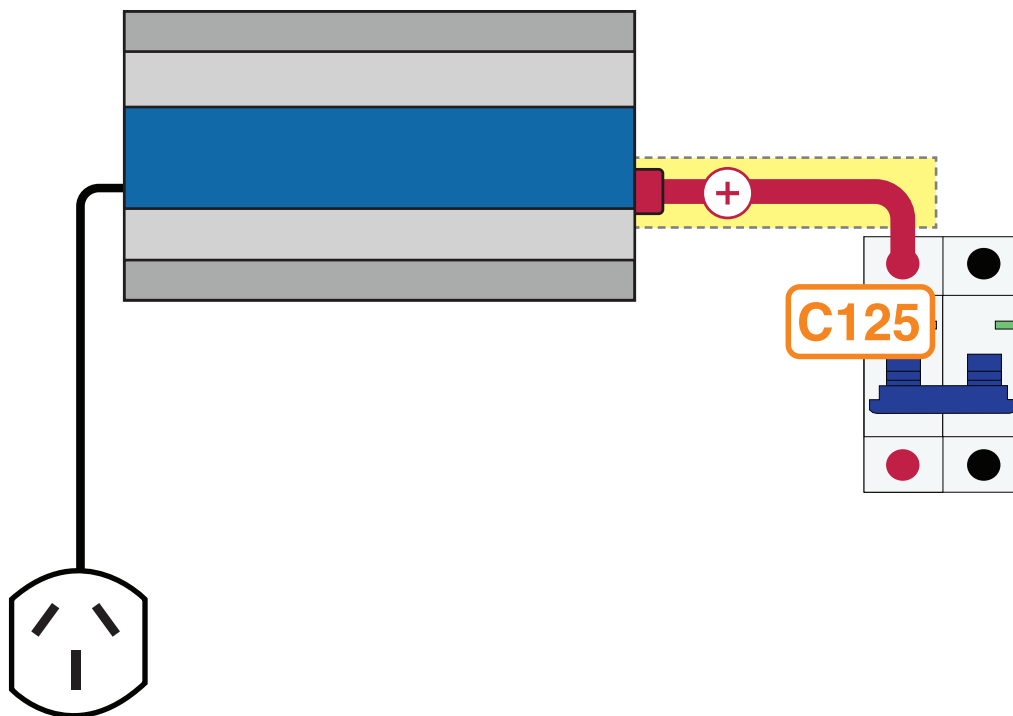

- 4 Wire the positive(+) 25mm² cable from the inverter to the C125 circuit breaker.

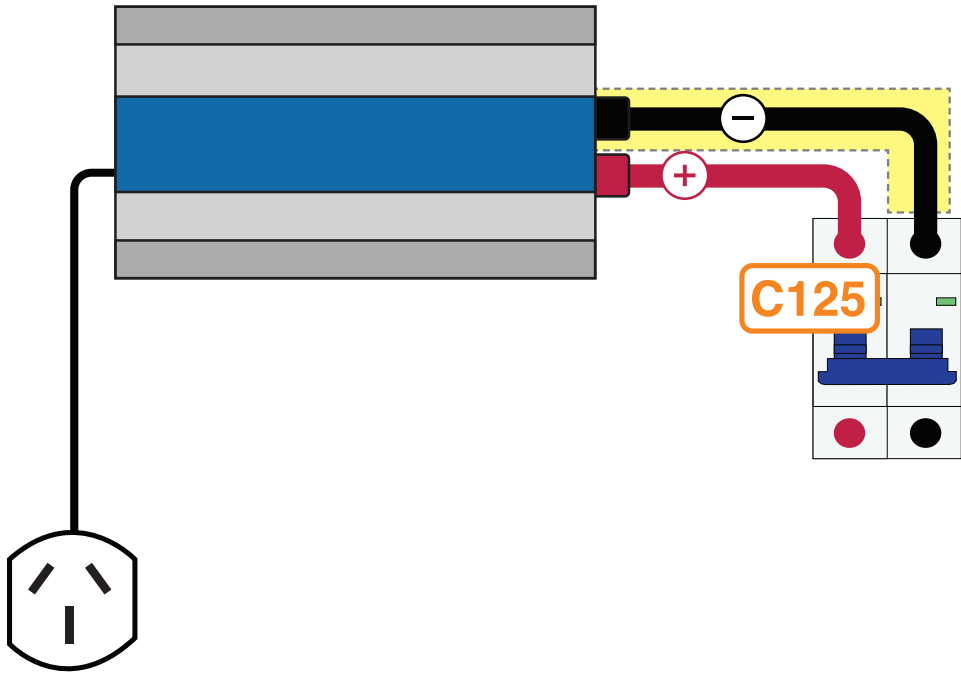

- 5 Wire the negative(-) 25mm² cable from the inverter to the C125 circuit breaker.

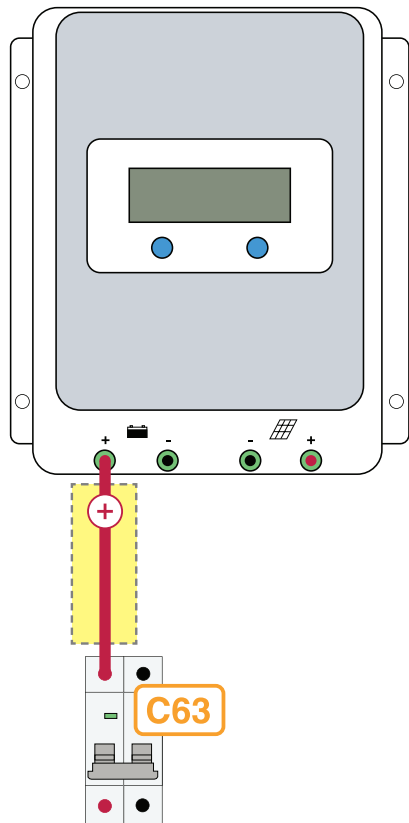

- 6 Wire the positive(+) 16mm² cable from the charge controller to the C63 circuit breaker.

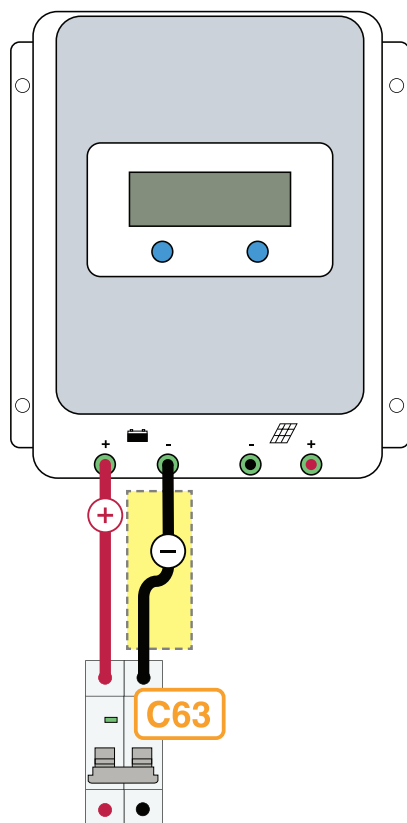

- 7 Wire the negative(-) 16mm² cable from the inverter to the C63 circuit breaker.

BATTERY WIRING

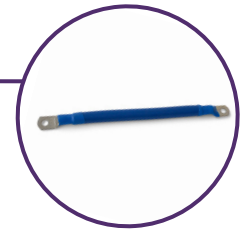
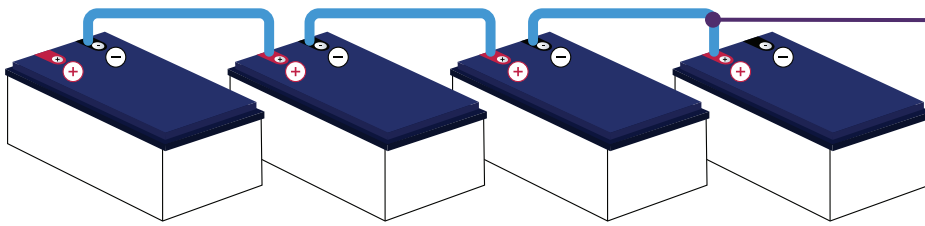

30cm Battery Link Cable

- 1 The battery bank is wired with four 12V batteries in series. This creates a 48V battery bank. The large gauge cable is used to connect the batteries together in series.

Wire the four batteries together from negative to positive with the blue battery link cable.



When wiring the blue cables, ensure that you fully attach each cable at both ends before moving onto the next.

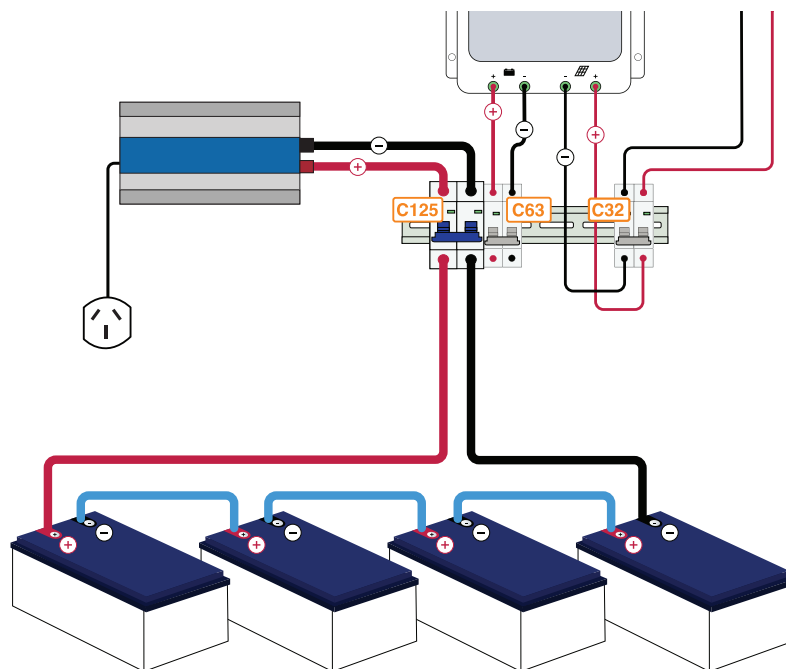

- 2 Wire the 25mm² 3m set of red and black cables to the inverter through the C125 circuit breaker.



When running the wires from the battery bank to the circuit breaker, be very careful not to touch the positive to the negative. This will cause a short circuit, which will result in a spark and possibly cause damage to the batteries or cables.

To minimise risk, we recommend only running one cable at a time and completely terminating the connections before moving onto the next starting at the breaker.

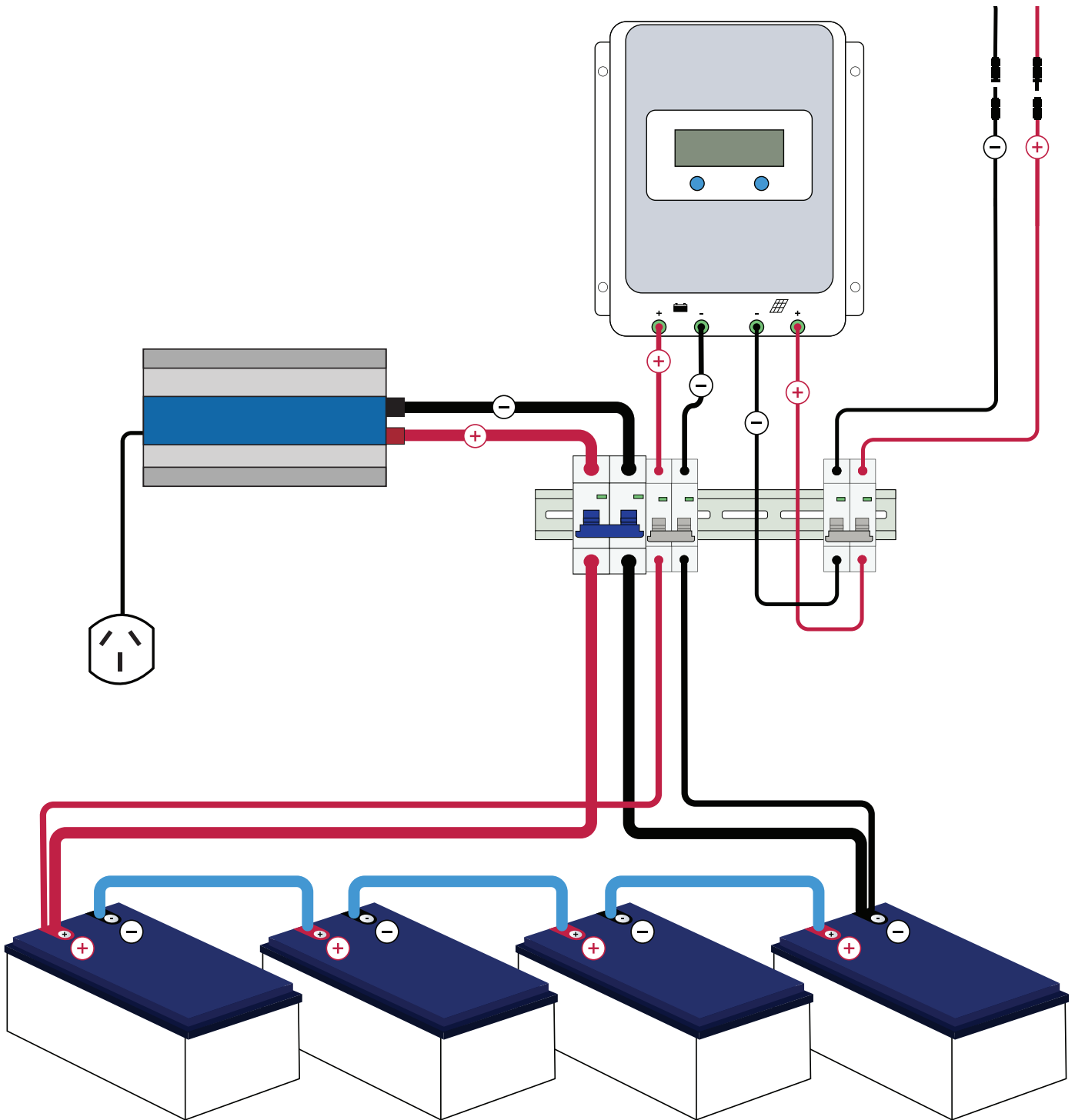

- 3 Wire the remaining set of red and black 16mm² cable to the charge controller through the C63 circuit breaker.

STARTUP PROCEDURE

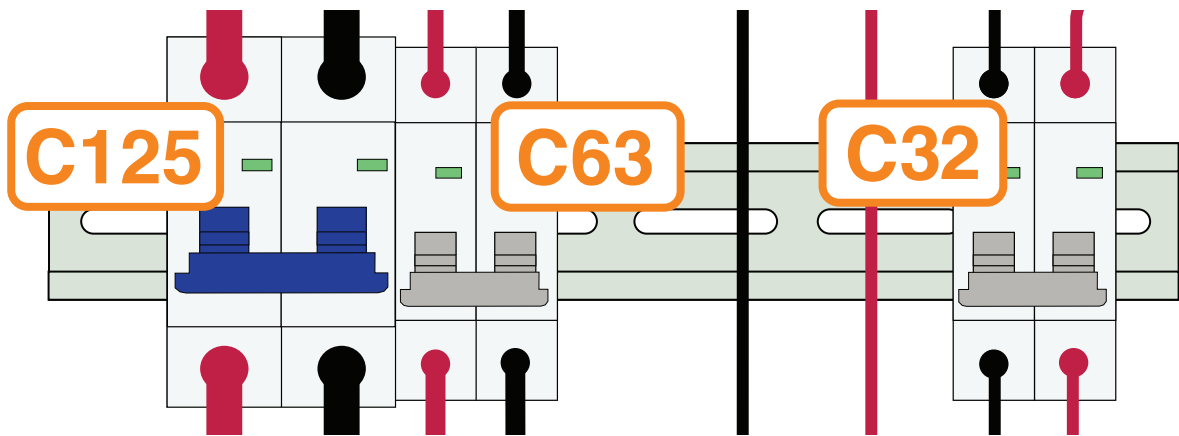

- 1 Switch on the circuit breakers in the following order:
 - i) Battery to charge controller breaker C63.
 - ii) Battery to inverter C125.
 - iii) Panels to charge controller C32.
-

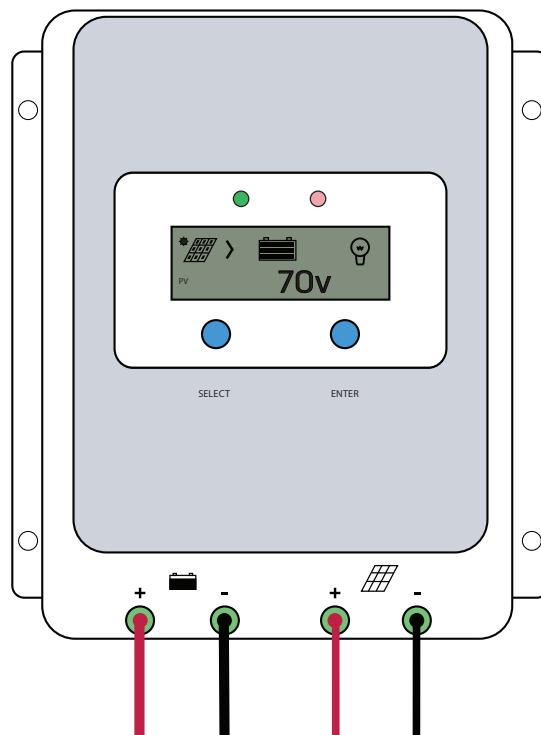

- 2 The green LED on the charge controller should be flashing, and the panel voltage should be around 60V-80V in full sunlight. As this charge controller auto-detects voltage, it can sometimes default to 12V on its first startup and give a battery over voltage warning.

To fix this, switch off all the circuit breakers in the reverse order of the previous step, and switch them back on again in the correct order.

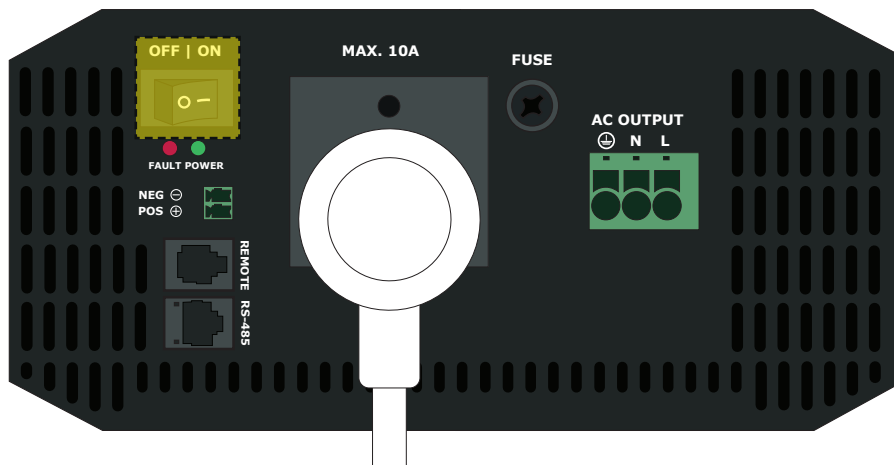

- 3 Flick the switch located on the side of the inverter to “ON”, and check that all three LED indicators are showing green. Other colours may indicate warnings or faults - please consult the inverter manual for more information.

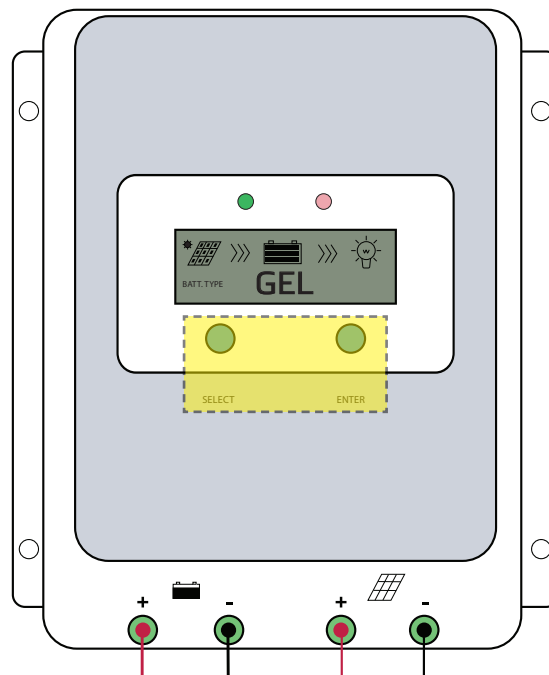

- 4 The system is now fully functional. The last step is to select the GEL battery charging mode on the charge controller. Click “SELECT” until the battery voltage interface is shown.

Hold down “ENTER” for 3 seconds, then click “SELECT” until “GEL” is displayed, and press “ENTER”.



The charge controller can be set to FLD by default. This is the incorrect charging range and will damage your batteries.

GETTING THE MOST OUT OF YOUR KIT

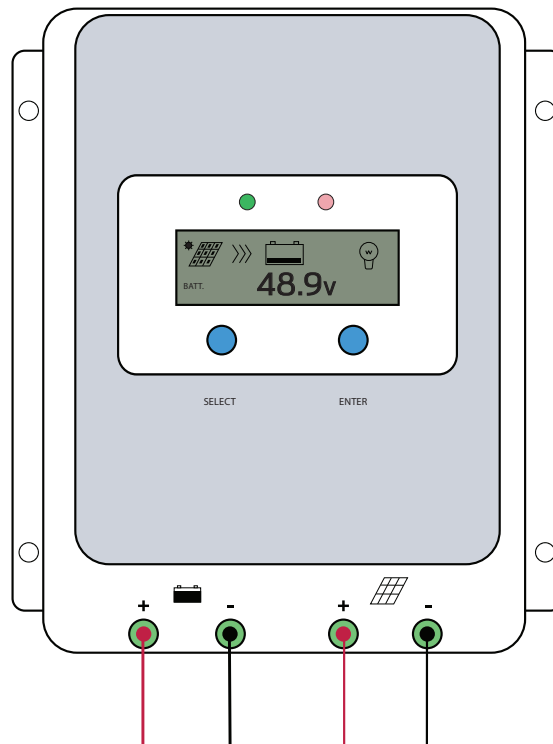

To get the most life out of your batteries, they should not be discharged lower than 50%.

You can check the state of charge of the batteries on the charge controller. Make sure the charge controller is on the screen shown above by pressing the “SELECT” button. The screen will display BATT on the left-hand side.

The charge controller displays the battery level in terms of voltage.

We have included this handy table that helps you convert from battery voltage to battery percentage.

The voltage will be higher than 51V when there is charge coming from the solar panels. Therefore, if the battery voltage displayed is a higher value than 51V, and there is less than 5A going into the batteries, the batteries will be at 100% charge.

Charge	Voltage
100%	51V - 60V
90%	50.5V
80%	50V
70%	49.5V
60%	49V
50%	48.5V

WHAT DIFFERENT CC SCREENS MEAN

Solar Panel Voltage

This shows the voltage of the solar panel array for this kit (between 60V and 75V). The voltage will be higher on sunny days than cloudy days.

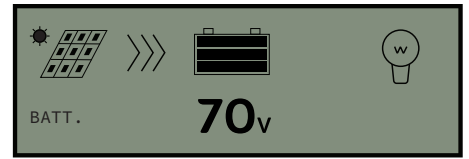

Solar Panel Charge Current

This screen displays the current coming from the solar panels, reading between 0A and 50A. This number will be low if it is cloudy or the batteries are fully charged.

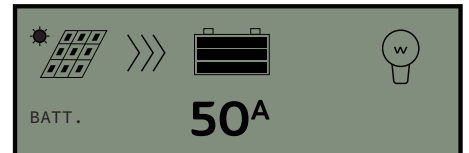

Total Power Generated

This screen displays the total power generated by the system since the last time it was turned on.

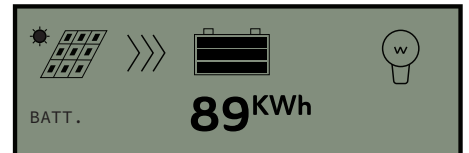

Battery Voltage

This screen displays the voltage of the battery bank and is one of the most important screens. Refer to the Battery Voltage to State of Charge conversion table to use this number to determine how much charge is in the batteries.

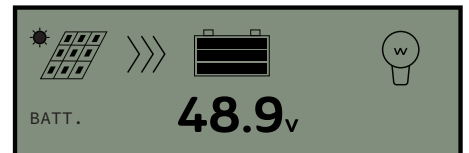

Battery Charge Current

This is the next most important screen - it shows how much charge is going into the batteries. This number should be high if the batteries are discharged and there is a lot of sunlight. If the batteries are fully charged, it is normal for this number to be close to zero.

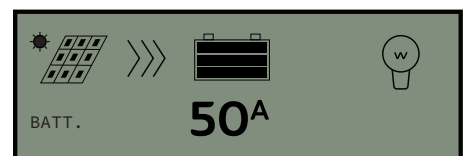

Remote Temperature

If a remote temperature sensor is installed, this screen will display the temperature reading.

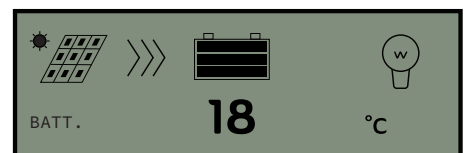

BATTERY CARE INFORMATION

What is Battery Cycle Life and Depth of Discharge?

Depth of Discharge is how much energy is discharged from the battery before it is charged to 100% again. A typical measurement is battery cycle life at 50% D.O.D (Depth of Discharge).

At 50% DOD, the battery has 50% of its energy capacity discharged before it begins charging again.

This is common in a solar situation where the sun charges the battery during the day, and then the energy stored in the battery is used to power appliances.

Cycle life measures how many cycles down to 50% it takes before the battery capacity is reduced to 60% of its power when brand new.

Do I need to add water to my battery?

No. Sealed lead acid batteries do not require additional water to maintain them.

What should I avoid when charging batteries?

1. Avoid mixing batteries of different sizes and ages – you will always be limited to the weakest battery in the string. For optimum performance, you should be using matched cells.
2. Don't run devices off just one battery to get 12V. Use a 48V to 12V step-down. This ensures that the current is shared equally between the batteries so that they are all put under equal stress and have the same lifespan.
3. Never go lower than 50% depth of discharge - not only will this permanently damage your battery, but it will **void your warranty**.
4. Always charge your batteries to 100% - leaving them partially charged will lead to sulfation and reduce your battery's capacity.
5. Don't let your batteries get too cold or too hot – about 20°C is an ideal temperature, and for best results, aim to keep them between 10°C to 30°C.

What happens if I over-discharge batteries?

OVER-DISCHARGING is a problem caused by insufficient battery capacity resulting in the batteries being overworked. Discharges deeper than 50% significantly shorten the Cycle Life of a battery. Infrequent or inadequate recharging can also cause rapid sulfation – a buildup of lead sulphate crystals covering the battery plates.

This coverage deteriorates the overall efficiency and power storage capability, meaning over-discharging will result in battery capacity loss.

It will also void your warranty.

How can you check a battery's performance?

As a battery ages, it will not have the same capacity it had when it was brand new. To test the battery's capacity, you will need to discharge the battery using a constant draw. By knowing how much current is being drawn, measuring the voltage at the beginning and the end of the test and timing the test, you can calculate the battery's capacity.

This can be a complex test and should only be done if you suspect the batteries are failing.

TROUBLESHOOTING GUIDE

We've compiled this list of common problems our customers may encounter with their solar gear to help you solve any issues as fast as possible.

Please contact us if you don't find the answers you need here or if your issue continues after implementing the given solutions.

1. My solar panels are not putting out as much power as normal

Once you've determined the drop in power is not due to weather changes, check your panels for any shade or shadows. Check both morning and afternoon in case the shadows are inconsistent. Ensure they're adequately cleaned, as things such as thick dust or bird droppings can affect your output. Finally, double check all your connections are clean and secure.

If none of these issues are causing your power drop, you'll need to send us clear pictures of your charge controller readings. We need to see the battery voltage, solar panel voltage, and solar panel amps. Please send readings from mid-day with peak sun and the end of the day or early morning.

2. My inverter keeps shutting off

Check your battery voltage, as inverters have an auto shut-off feature to protect them from damage when the voltage drops too low. The manual with your inverter will have this information and a troubleshooting guide.

3. My charge controller is in night mode

Check all the breakers and the wiring going into the breakers for any loose connections. You want to ensure the wires are tight, the metal wire is entirely in contact with the breaker, and the insulation is not preventing a solid connection. Then, check your solar panels' wiring, ensuring all connections are secure and the wires aren't damaged.

Once you ensure all connections are secure, reboot your charge controller by switching the breakers off and back on, as sometimes the charge controller will auto-detect the wrong voltage setting during the first boot-up.

4. My batteries aren't charging

It's likely your batteries have been drawn very low and cannot charge fully if you continue to draw power. Check all the wiring is secure and undamaged, then turn off the breaker between the batteries and the inverter, leaving the others on, and let the batteries charge back up to full.

If you don't believe you have knowingly used enough power to drain the batteries, check all your appliances to see if something is using more power than it should.

5. My batteries drain very fast when the sun goes down

The controller may read 100% while charging at the higher voltage, but it will quickly drop lower when no charge is applied. This could be because the batteries charge at a higher voltage, so when the sun goes down, the battery voltage will stabilise at a lower level. It may also mean the batteries have been drained low, and they need to get more charge to be fully charged by the end of the day.

Try reducing your power usage for a few days to ensure the batteries are fully charged. You should also check that the solar panels have total sunlight exposure or whether an appliance has been left on. When customers notice less solar output, the most common cause is shading - as we transition between winter and summer, the sun's path changes and can cast new shadows across the panels, which weren't noticed when you first installed the system.

6. My inverter beeped, and an orange light was flashing

If you check quickly, you may hear your charge controller beep and see an orange light blinking.

This occurs when the battery voltage is too high, and the charge controller is charging the batteries completely.

This usually happens on a very sunny day or when using a high-draw appliance (e.g. toaster). When the high-draw apparatus stops, the solar works very quickly to top off the batteries and can peak the voltage briefly. As it's a smart inverter, it works to protect itself and your batteries, so it can sometimes be a little bit on the overprotective side.

7. My inverter fan turns on all the time

You may notice the fan turning on even when you're not using a high-load appliance. The inverter can sometimes be a little overprotective of itself, especially on warm days, and the fan will turn on when it doesn't seem necessary. Make sure there is sufficient airflow around your inverter, and you should be fine.

CONTACT US

Our website: gridfree.store

Email us: info@gridfree.store

Message us on Facebook: [@GridFree.Store](https://www.facebook.com/GridFree.Store)

Give us a call: (09) 218 5533

Address: By Appointment– C4/27 Smales Road, East Tāmaki, Auckland, 2013

Hours: 9am-5pm, Monday-Friday

Kit viewings, demos, and pick ups at Auckland warehouse by appointment only.
Please give us a call and we'll be happy to set up a time to meet you.

NOTES



GRIDFREE