



original instructions **IT**

USER MANUAL  
**High vision**



00\_112020



## INDEX

---

### 03 GENERAL INFORMATION

- 03 Purpose of the manual
- 03 Conservation of the manual
- 03 Reading the manual
- 04 Manufacturer
- 04 Certification
- 05 Warranty
- 05 Returns
- 05 Safety rules

---

### 06 DESCRIPTION

- 06 General description
- 07 Technical data
- 07 Sizes and overall dimensions

---

### 08 INSTALLATION

- 08 Display installation
- 10 Keypad installation
- 11 Transport, packaging and storage

---

### 12 USE

- 12 Commands
- 13 Navigation diagram
- 14 Power on
- 14 Power off
- 15 Home
- 16 General screen layout
- 17 Distance screen
- 17 Time screen
- 17 Pace screen
- 17 Energy screen
- 18 "Race" screen
- 19 Summary screen
- 20 Assistance level
- 21 Walk mode
- 22 eBike light adjustment
- 23 Menu
- 24 Reset trip
- 24 System info

---

### 25 Advanced

- 26 Screen brightness
- 27 Language
- 28 Unit of measure
- 29 Weight
- 30 Gender
- 31 Night mode

---

### 32 TROUBLESHOOTING

- 32 Error codes
- 35 Technical assistance
- 36 Cleaning and maintenance
- 36 Disposal

---

### 35 MAINTENANCE AND ASSISTANCE

- 35 Technical assistance
- 36 Cleaning and maintenance



## GENERAL INFORMATION

### DESCRIPTION

### INSTALLATION

### USE

### TROUBLESHOOTING

### MAINTENANCE AND ASSISTANCE

## PURPOSE OF THE MANUAL

This manual is an integral part of the HMI unitHIGH VISION and has been drawn up by the manufacturer in its original language (Italian) to provide all the information necessary for an adequate and safe use of the unit throughout its life cycle: from transport to delivery, use and maintenance, up until disposal .

Before carrying out any operation, users and technicians must carefully read the instructions and strictly comply with them.

In the case of doubts in correctly interpreting them, contact the manufacturer to obtain the necessary clarifications. The regular operation of the unit over time will be ensured and the occurrence of dangerous situations for people and things will be avoided only by observing what is reported below.

The manual provides warnings and instructions relating to safety regulations for the prevention of accidents. In any case, operators must observe the safety regulations imposed on them by the regulations in force with the utmost attention. Any changes to the safety regulations that may take place over time must be acknowledged and implemented.

 **It is recommended to read this manual carefully before putting the unit into operation.**

With a view to continual improvement, OLI eBike Systems may change some characteristics of the

components used without prior notice. This does not affect the validity of the information contained in this document. If inconsistencies are found between what is described in the manual and the use of the unit, please notify the manufacturer.

 *The updated copy of this manual is available on the website [www.oli-ebike.com](http://www.oli-ebike.com).*

## CONSERVATION OF THE MANUAL

The manual must accompany the unit throughout its lifecycle and must be available to all the operators and technicians who may need it.

The manual must follow the unit if it is transferred to a new user or owner.

## READING THE MANUAL

To consult the manual you can use:

- › the initial index;
- › the menu on the left side of each page;
- › the references indicated with *see "chapter name" on page.00*.

If using a digital format, to make the most of the interactive navigation functions, we recommend opening it with the free Adobe reader software (<https://get.adobe.com/it/reader/>).

The icon  indicates additional interactive areas other than those listed above.



- GENERAL INFORMATION**
- DESCRIPTION
- INSTALLATION
- USE
- TROUBLESHOOTING
- MAINTENANCE AND ASSISTANCE

## MANUFACTURER

OLI eBike System is at your disposal for any problem or information.

Communications and requests can be sent to:



### OLI eBike Systems

Via delle pesche, 891  
47522 Cesena (FC) ITALY



### contact details

Tel +39 0547 318322  
info@oli-ebike.com



### site

[www.oli-ebike.com](http://www.oli-ebike.com)



For any need concerning the use, maintenance or request for spare parts, please specify the unit identification data shown on the manufacturer's plate.

## CERTIFICATION

The unit HIGH VISION was made in compliance with the relevant Community Directives applicable at the time of its being placed on the market, and therefore it meets the safety requirements of the machinery directive 2006/42 / EC and the UNI EN 15194: 2018 standard.

The unit complies with the laws in force.

Being a product undergoing significant technical and regulatory development, OLI eBike Systems reserves the right to update it as quickly as possible to the latest technological knowhow and the official applicable standards (UNI, EN, ISO) that become available from time to time.

All the products described in this manual have been manufactured according to the operating procedures defined by the Quality System of OLI eBike Systems, a division of OLI®spa. The company's Quality System, certified in accordance with the UNI EN ISO 9001 Standard, is able to ensure that the entire production process, from the formulation of the order to technical assistance following delivery, is carried out in a controlled and adequate manner in order to guarantee the quality standards of the product.



## GENERAL INFORMATION

### DESCRIPTION

### INSTALLATION

### USE

### TROUBLESHOOTING

### MAINTENANCE AND ASSISTANCE

## WARRANTY

The unit is covered by a warranty on materials for a period of 36 months from the date shown on the shipping document. The buyer loses the right to the warranty in the case of incorrect use or when he or she has made changes or repairs to the supplies without the manufacturer's authorization.

Upon receipt of the product, the recipient must check that there are no defects or damages resulting from transport and / or incompleteness in the supplies. Any complaints must be reported immediately to the manufacturer by means of a written communication countersigned by the carrier.

Labour services, such as sending a technician, are excluded from the warranty.

In no case can compensation for damages be demanded.

For further information on the conditions of assistance under warranty, please refer to the sales contract.

 *Products shipped for repair under warranty must be returned carriage paid to the manufacturer's factory.*

## RETURNS

In case of return, if you have kept the original packaging, reuse it for shipping.

Otherwise, place the unit in a box trying to protect it as well as possible from any impacts resulting from transport.

## SAFETY RULES

In order to minimize the causes that can create dangerous situations for users and others, we invite you to adopt appropriate rules of conduct.

In particular, the following points should be observed when using the eBike:

- › consult your doctor before starting an exercise program;
- › observe the traffic regulations relating to pedal-assisted bicycles;
- › do not get distracted by looking at the display when riding the bicycle;
- › do not use the display as a handle;
- › exclusively use the HMI unit and the supplied keypad;
- › remove the battery before carrying out any type of intervention.

 *The manufacturer declines all responsibility in case of damage to persons or things deriving from improper use of the unit or failure to observe the instructions given in the manual.*

## GENERAL INFORMATION

## DESCRIPTION

## INSTALLATION

## USE

## TROUBLESHOOTING

## MAINTENANCE AND ASSISTANCE

### GENERAL DESCRIPTION

HIGH VISION is an HMI unit that allows you to analyse and view data relating to the eBike and the training in progress.

The unit consists of a sturdy, injection-moulded ABS body housing the LCD display and a keypad containing the keys that allow for control and navigation.

**⚠** The unit **HIGH VISION** is exclusively intended for use as an HMI on an eBike. Uses other than those foreseen and not compliant with what is described in this manual, as well as being considered improper and prohibited, can create dangerous conditions for people and things.

**ⓘ** *The manufacturer declines all responsibility for improper use of the product.*

The unit consists of the following components:

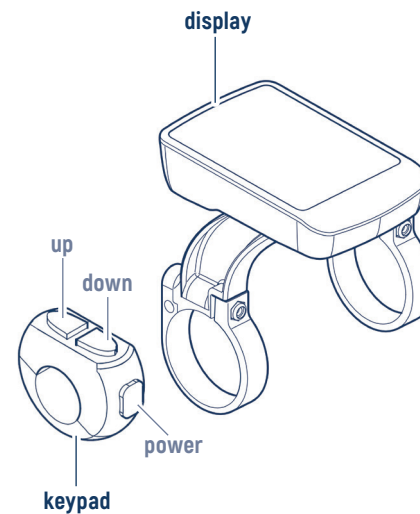

## GENERAL INFORMATION

## DESCRIPTION

## INSTALLATION

## USE

## TROUBLESHOOTING

## MAINTENANCE AND ASSISTANCE

### TECHNICAL DATA

Display type Dot matrix LCD

Operating temperature -5°C / 40°C

Storage temperature -20°C / 60°C

Degree of protection IP 67

### SIZES AND OVERALL DIMENSIONS

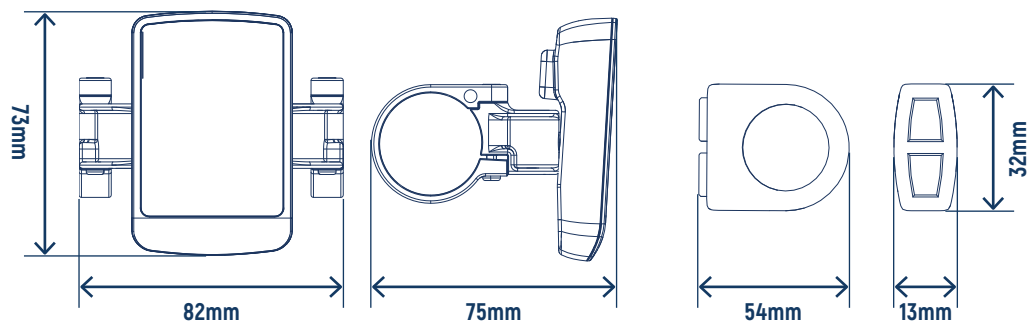



GENERAL  
INFORMATION

DESCRIPTION

INSTALLATION

USE

TROUBLESHOOTING

MAINTENANCE AND  
ASSISTANCE

## DISPLAY INSTALLATION

**1 >** Insert the display holder rings on the handlebar.

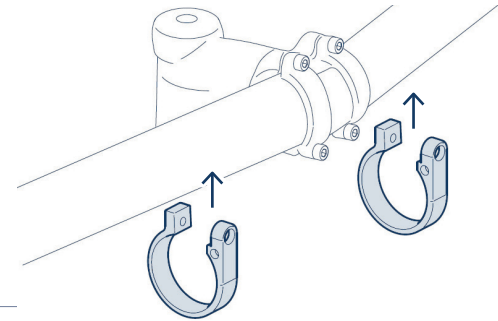

**2 >** Install the display on the support, tightening the M4 fixing screws.



1.5 - 3 Nm

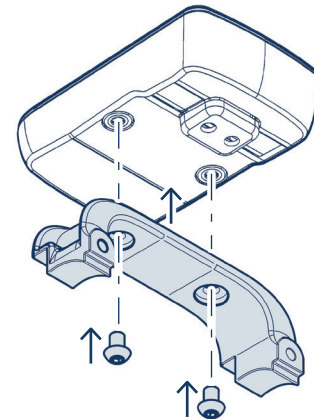





## GENERAL INFORMATION

## DESCRIPTION

## INSTALLATION

## USE

## TROUBLESHOOTING

## MAINTENANCE AND ASSISTANCE

**3** > Position the display on the supports paying attention to the angle (15 ° - 35 ° with respect to the horizontal plane) and tighten the fixing screws with the nuts.



1.5 - 3 Nm

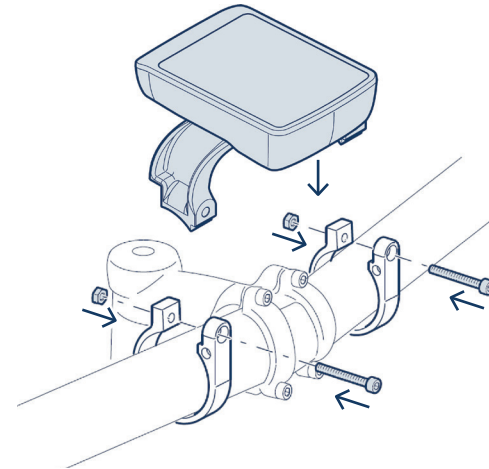



## GENERAL INFORMATION

## DESCRIPTION

## INSTALLATION

## USE

## TROUBLESHOOTING

## MAINTENANCE AND ASSISTANCE

### KEYPAD INSTALLATION

**1** > Position the keypad while paying attention to the angle (15° - 35° with respect to the horizontal plane), so as to allow the user to operate it comfortably while moving.

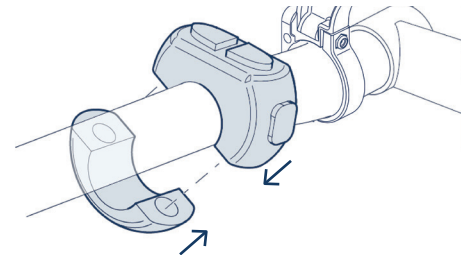

**2** > Tighten the fixing screws.



1.5 - 3 Nm

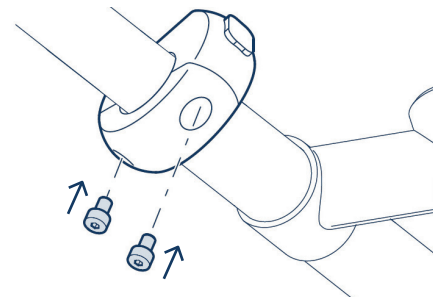

**3** > Insert the display cable into the frame to be able to connect it to the power unit.

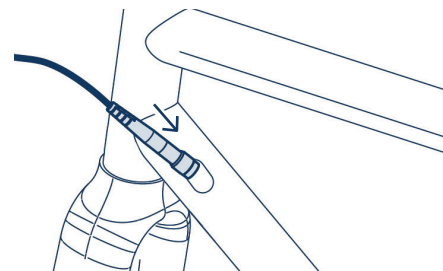



GENERAL  
INFORMATION

DESCRIPTION

INSTALLATION

USE

TROUBLESHOOTING

MAINTENANCE AND  
ASSISTANCE

## TRANSPORT, PACKAGING AND STORAGE

The unit is supplied with dedicated packaging which avoids damage from transport.

Upon receipt of the goods, the customer must check whether the model and quantity received correspond to the data in the order confirmation.

The components must be stored indoors in dry environments, protected from atmospheric agents and at temperatures above  $-10^{\circ}\text{C}$ .







 *It is the user's responsibility to properly dispose of the packaging in compliance with the laws in force.*

- GENERAL INFORMATION
- DESCRIPTION
- INSTALLATION
- USE**
- HOME
- MENU
- ADVANCED
- TROUBLESHOOTING
- MAINTENANCE AND ASSISTANCE

## COMMANDS

To navigate the software there are 3 keys that can be used with short press or with a press of more than 2 seconds.

Throughout this manual, the following icons are used to indicate the type of key and press for each action.

key	short press / <1 second [1"]	long press /> 2 seconds [2"]
power	 allows you to: scroll on the Home screen from one main screen to another; scroll between the Home screen and the Menus; confirm the action during the changes.	 allows you to: turn the display on or off; from the Menu and Advanced section, return to the last displayed Home screen.
up	 allows you to scroll through the menu items, going up	 from any main screen allows you to change the operating mode of the lights
down	 allows you to scroll through the menu items, going down	 from any main screen allows you to activate Walk mode
down+up	-	 from the main screens, pressing the two keys simultaneously allows access to the Menu

- GENERAL INFORMATION
- DESCRIPTION
- INSTALLATION
- USE**
- HOME
- MENU
- ADVANCED
- TROUBLESHOOTING
- MAINTENANCE AND ASSISTANCE

### NAVIGATION DIAGRAM

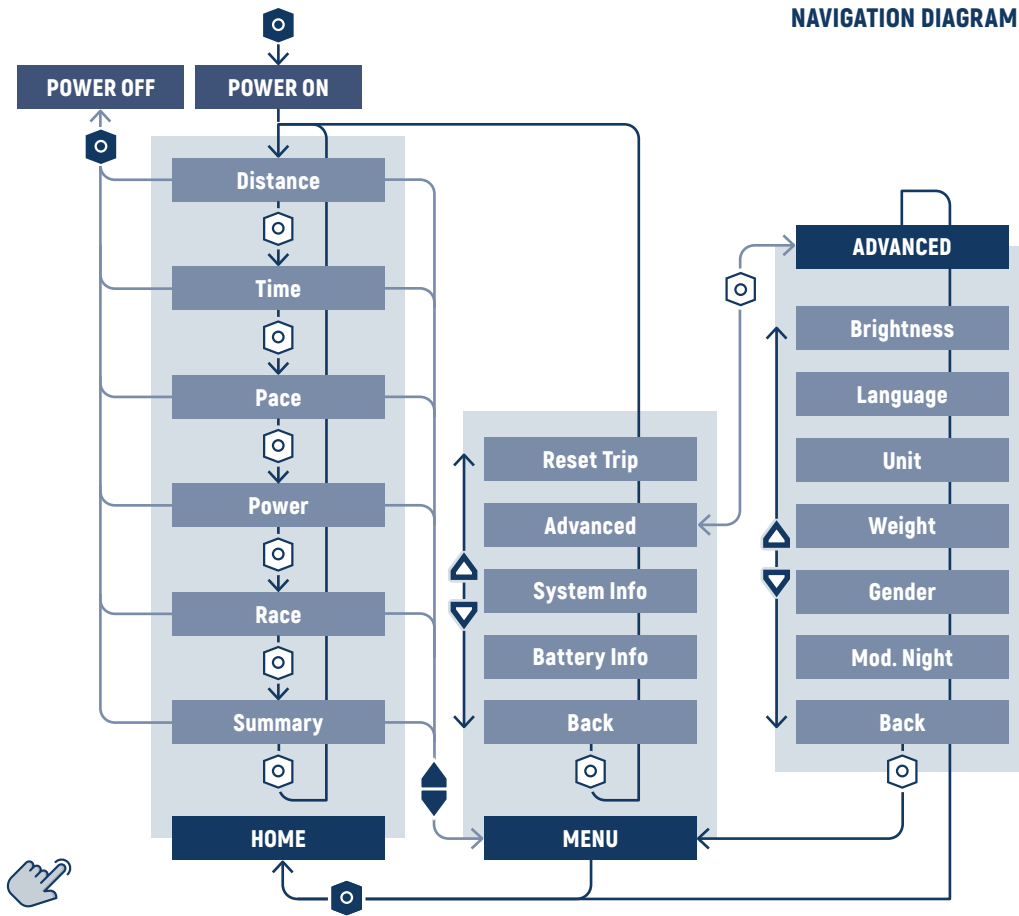

## GENERAL INFORMATION

## DESCRIPTION

## INSTALLATION

## USE

### HOME

### MENU

### ADVANCED

## TROUBLESHOOTING

## MAINTENANCE AND ASSISTANCE

### POWER ON

To turn on the display, depending on the type of battery installed:

- › press and hold the power-on key until the power-on screen with the manufacturer's logo is displayed or press the on key on the battery.

Wait a few seconds to display the first Home screen.

### POWER OFF

To turn off the display, depending on the type of battery installed:

- › press and hold the power-on key until the power-off screen appears or press the off key on the battery.

Wait a few seconds for the system to shut down completely.

**I** *If the eBike is not used for a certain amount of time, depending on the type of battery, the system will switch off automatically.*

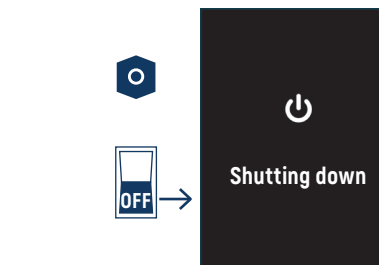
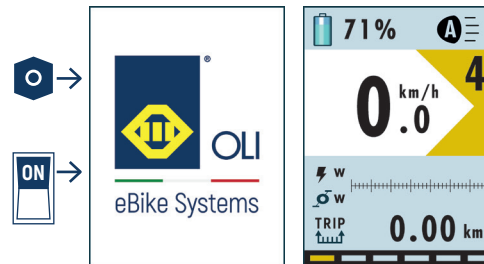





- GENERAL INFORMATION
- DESCRIPTION
- INSTALLATION
- USE**
- HOME
- MENU
- ADVANCED
- TROUBLESHOOTING
- MAINTENANCE AND ASSISTANCE

### HOME

After powering on, the first Distance screen of the Home section is displayed.  
 The Home section consists of 6 screens.  
 To scroll through the screens you need to press the power-on key .

From any screen in the Home section, you can:

- ▶ adjust the assistance level by pressing the up  and down keys ;
- ▶ enter Walk mode by holding down the down key .
- ▶ adjust the brightness of the eBike lights by holding down the up key  for 2";
- ▶ enter the Menu section by holding down the up + down keys at the same time  for 2".

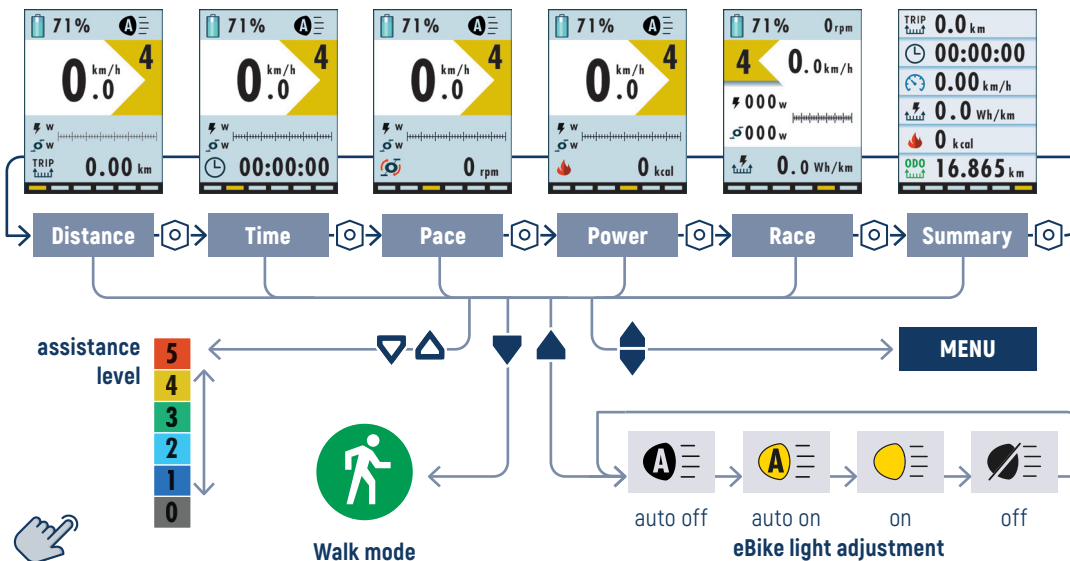

GENERAL INFORMATION

DESCRIPTION

INSTALLATION

USE

HOME

MENU

ADVANCED

TROUBLESHOOTING

MAINTENANCE AND ASSISTANCE

General screen layout

The screens in the Home section differ from each other in the type of information displayed.

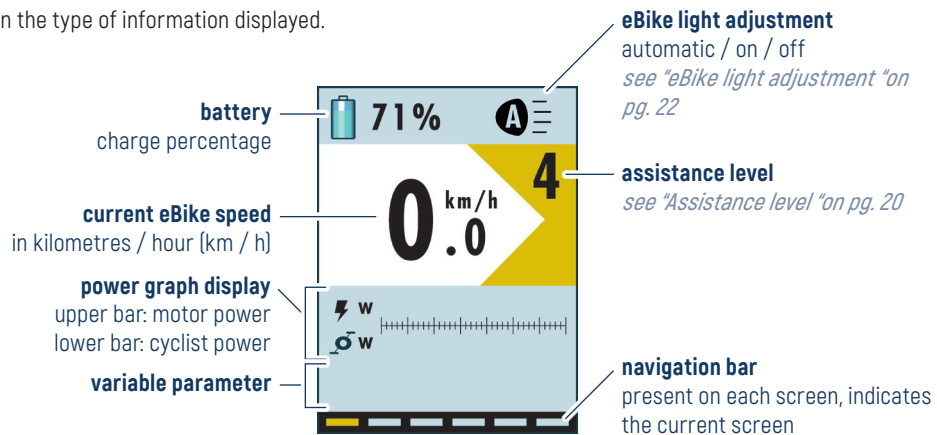

parameters indicated in the screens



motor power



cyclist power



TRIP distance travelled from the start of the lap



time elapsed since the start of the lap



pedal pace



energy burned by the cyclist



average consumption of the eBike



ODO total distance travelled



average speed



GENERAL INFORMATION

DESCRIPTION

INSTALLATION

USE

HOME

MENU

ADVANCED

TROUBLESHOOTING

MAINTENANCE AND ASSISTANCE

The first 4 screens differ only for the variable parameter which is described below.

*To reset the datasee "Reset trip "on pg. 24.*

*For other screen datasee "General screen layout "on pg. 16.*

**Distance screen**

**TRIP**  Indicates the distance travelled in kilometres (km) since the last reset.



**Time screen**

 Indicates the time elapsed in motion since the last reset. The value is expressed in hours: minutes: seconds.



**Pace screen**

 Indicates the instantaneous speed of rotation of the rotating pedals per minute (rpm).



**Energy screen**

 Indicates the energy consumed by the cyclist in kilocalories (kcal) since the last reset.

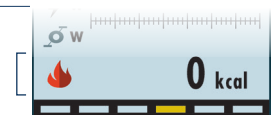

GENERAL INFORMATION

DESCRIPTION

INSTALLATION

USE

HOME

MENU

ADVANCED

TROUBLESHOOTING

MAINTENANCE AND ASSISTANCE

"Race" screen

It is the fifth screen of the Home section. In this screen, the values in watts (w) of the motor power and cyclist power are expressed in full.

 Indicates the instantaneous power delivered by the motor in watts (w).

 Indicates the instantaneous power expressed by the cyclist in watts (w).

 Power graph display  
upper bar: motor power  
lower bar: cyclist power

 Indicates the average energy consumption in watt-hours per kilometre (Wh / km), calculated since the last reset.

This data allows you to adjust the level and, therefore, the consumption of the eBike according to the need. By calculating the relationship between this data and the battery capacity, the exact distance possible for each charge is obtained.

*To reset the datasee "Reset trip "on pg. 24.*

*For other screen datasee "General screen layout "on pg. 16.*

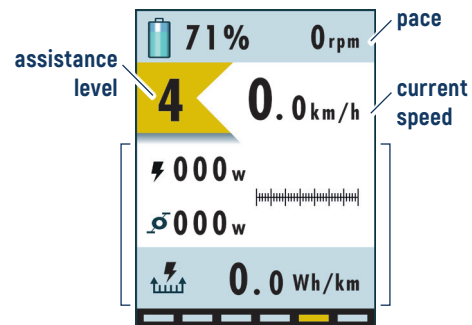

$$\text{battery capacity} \div \text{average consumption} = \text{Kms that can be travelled}$$

GENERAL INFORMATION

DESCRIPTION

INSTALLATION

USE

HOME

MENU

ADVANCED

TROUBLESHOOTING

MAINTENANCE AND ASSISTANCE

**Summary screen**

It is the sixth screen of the Home section. This screen summarizes the variable parameters of the previous screens.

- 

Indicates the distance travelled in kilometres (km) since the last reset.
- 

Indicates the time elapsed in motion since the last reset. The value is expressed in hours: minutes: seconds.
- 

Indicates the average speed in kilometres per hour (km / h) measured since the last reset.
- 

Indicates the average energy consumption in watt-hours per kilometre (Wh / km), calculated since the last reset.
- 

Indicates the energy consumed by the cyclist in kilocalories (kcal) since the last reset.
- 

Indicates the total distance travelled by the eBike in kilometres (km). Non-resettable value.



*To reset the data of these parameters see "Reset trip" on pg. 24.*

*For other screen data see "General screen layout" on pg. 16.*

GENERAL INFORMATION

DESCRIPTION

INSTALLATION

USE

HOME



MENU

ADVANCED

TROUBLESHOOTING

MAINTENANCE AND ASSISTANCE

**Assistance level**

From any screen in the Home section it is possible to change the assistance level by pressing the up key  to increase it and the down key  to decrease it.

The table shows the multiplication factor for each level of assistance.

level	multiplicative factor
0	0% (motor inactive)
1	50%
2	100%
3	200%
4	300%
5	400%

The assistance percentages of the levels are indicative because they can be customized by the eBike manufacturer.

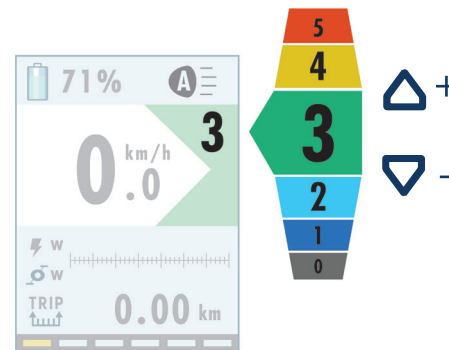



- GENERAL INFORMATION
- DESCRIPTION
- INSTALLATION
- USE**
- HOME
- MENU
- ADVANCED
- TROUBLESHOOTING
- MAINTENANCE AND ASSISTANCE

### Walk mode

The system is equipped with a walk assistance function, which allows you to activate the motor up to a maximum speed of 6 km / h, allowing you to tackle short stretches more easily by pushing the eBike.

To activate the walk assistance function, press and hold the down key ▼. The motor will start in Walk mode and the corresponding icon will appear on the display. To deactivate Walk mode, release the down key ▼.

The motor will shut down in the following cases:

- › release of the down key ▼,
- › speed exceeding 6 km / h,
- › locking the eBike wheel.

 *If assistance level zero [0] is set, the motor is disabled and the walk assistance function cannot be used.*

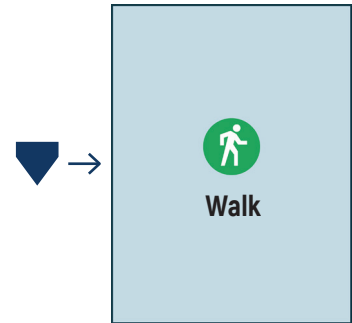



- GENERAL INFORMATION
- DESCRIPTION
- INSTALLATION
- USE**
- HOME
- MENU
- ADVANCED
- TROUBLESHOOTING
- MAINTENANCE AND ASSISTANCE

### eBike light adjustment

The lights of the eBike can be adjusted in four different ways:

- › automatic off (default setting at power-on), shutdown takes place automatically by means of the twilight sensor integrated in the HMI which detects the ambient brightness level;
- › automatic on, switching on takes place automatically through the twilight sensor integrated in the HMI which detects the level of low ambient light;
- › on, lights always on;
- › off, lights always off.

To change the operating mode of the lights:

- › press and hold the up key ▲ for 2",
- › the lights change mode and the icon in the display changes status,
- › release the up key ▲ to confirm the mode.

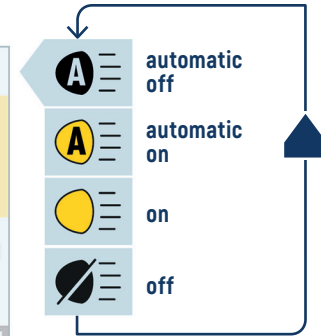
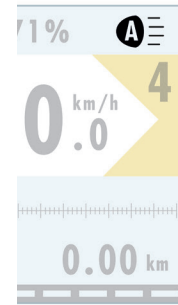



- GENERAL INFORMATION
- DESCRIPTION
- INSTALLATION
- USE**
- HOME
- MENU**
- ADVANCED
- TROUBLESHOOTING
- MAINTENANCE AND ASSISTANCE

### MENU

From the Home section, hold down the up + down keys at the same time  for 2" to enter the Menu section.

From any screen, by holding down the power-on key  for 2", you can return to the last viewed Home screen.

From the Menu page:

- › use the up  and down keys  to scroll through the items present, the selected item is highlighted in the centre in the white line,
- › press the power-on key  to confirm and open the page of the selected item, the Back item takes you to the first screen of the Home section.

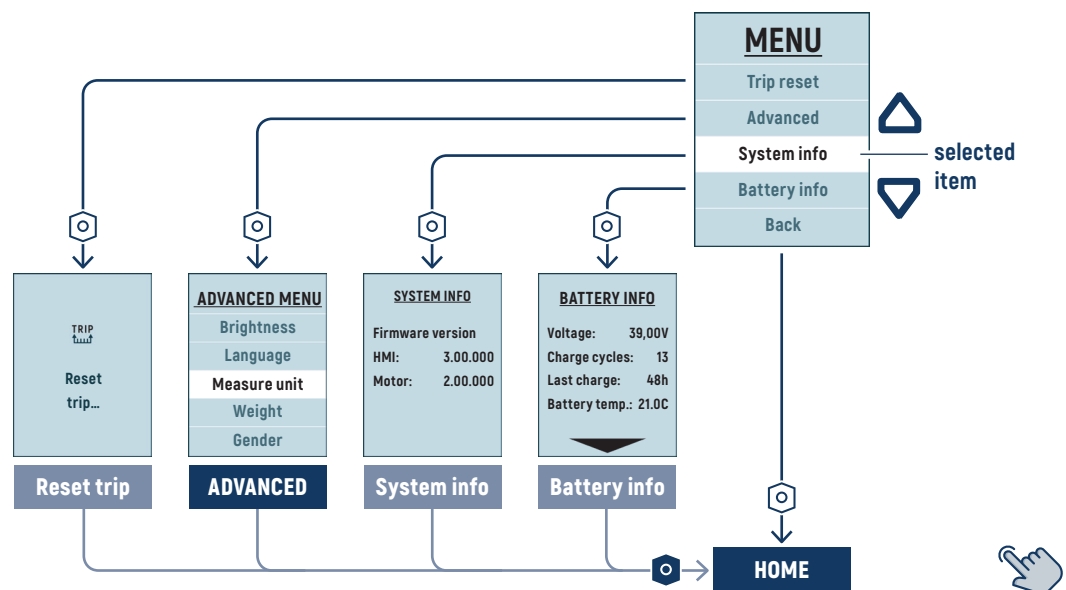

- GENERAL INFORMATION
- DESCRIPTION
- INSTALLATION
- USE**
- HOME
- MENU**
- ADVANCED
- TROUBLESHOOTING
- MAINTENANCE AND ASSISTANCE

### Reset trip

The Reset trip item allows you to reset all the recorded lap data by returning the counters to zero (0).

By pressing the power-on key  it starts immediately upon reset.

The message "Trip reset ..." appears on the display for a few seconds, when the reset is complete, the Menu page is displayed again.

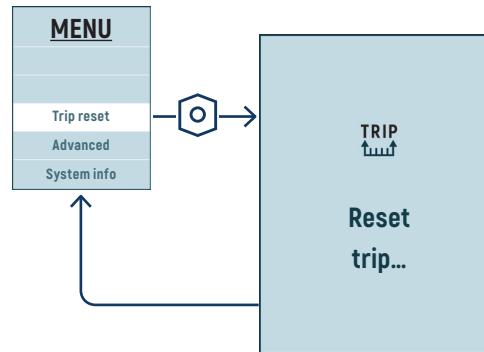

### System info

In this screen you can view the firmware versions:

- › of the installed HMI,
- › of the associated motor.

Press the power-on key  to return to the Menu.

**SYSTEM INFO**

**Firmware version**

**HMI:            3.00.000**

**Motor:         2.00.000**





- GENERAL INFORMATION
- DESCRIPTION
- INSTALLATION
- USE**
- HOME
- MENU
- ADVANCED**
- TROUBLESHOOTING
- MAINTENANCE AND ASSISTANCE

### ADVANCED

From the Menu section it is possible to access the Advanced section by selecting the relevant item.

From any screen, by holding down the power-on key  for 2", you can return to the last viewed Home screen.

From the Advanced page:

- › use the up  and down keys  to scroll through the items, the selected item is highlighted in the centre in the white line,
- › press the power-on key  to confirm and open the page of the selected item, the Back item takes you back to the Menu page.

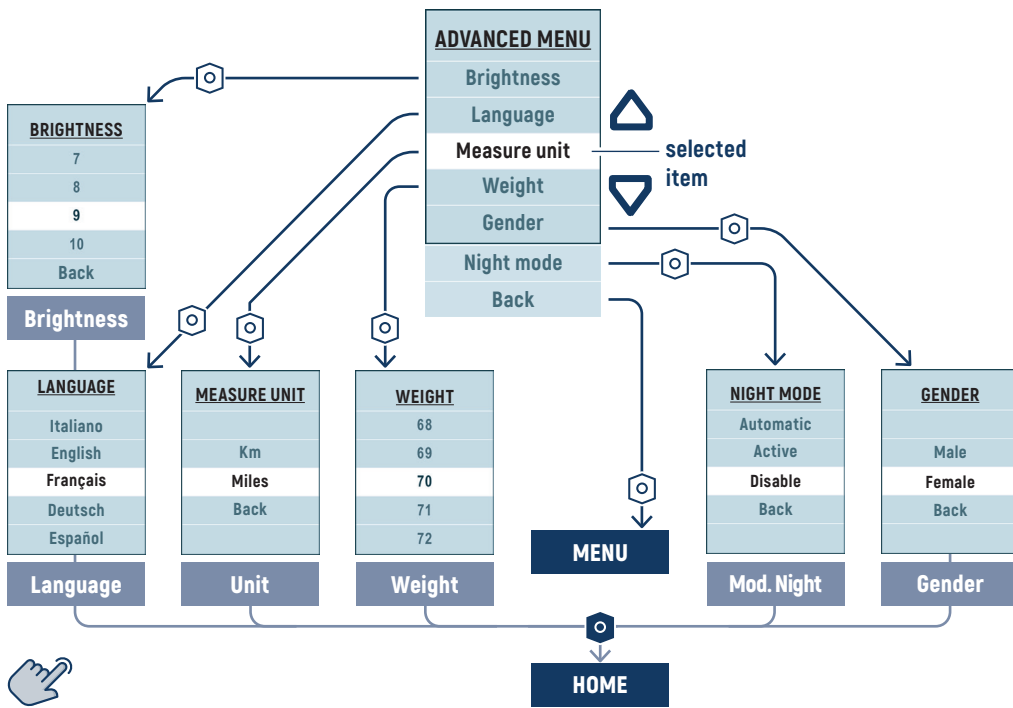





- GENERAL INFORMATION
- DESCRIPTION
- INSTALLATION
- USE**
- HOME
- MENU
- ADVANCED
- TROUBLESHOOTING
- MAINTENANCE AND ASSISTANCE

### Screen brightness

From this screen, you can adjust the brightness of the screen.

Use the up  and down keys  to scroll through the values from 1 to 10. The selected value is highlighted in the centre in the white line.

Press the power-on key  to confirm and return to the Advanced page.

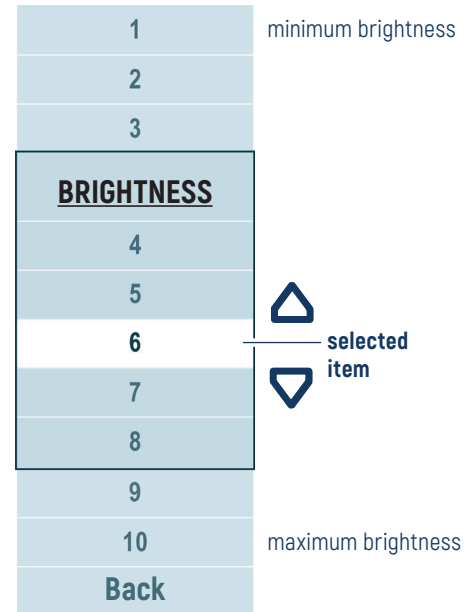

Select the Back item and press the power-on key  to return to the Advanced page without setting any value.



GENERAL INFORMATION
DESCRIPTION
INSTALLATION
<b>USE</b>
HOME
MENU
ADVANCED
TROUBLESHOOTING
MAINTENANCE AND ASSISTANCE

### Language

From this screen you can choose the language of the unit's text.

Use the up  and down keys  to scroll through the available items. The selected value is highlighted in the centre in the white line.

Press the power-on key  to confirm and return to the Advanced page.

Select the Back item and press the power-on key  to return to the Advanced page without changing the language.

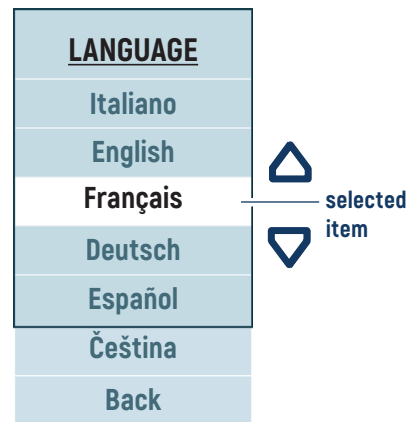





- GENERAL INFORMATION
- DESCRIPTION
- INSTALLATION
- USE**
- HOME
- MENU
- ADVANCED
- TROUBLESHOOTING
- MAINTENANCE AND ASSISTANCE

### Unit of measure

From this screen it is possible to select the unit of measure with which the following are calculated:

- › instantaneous speed,
- › average speed,
- › average consumption,
- › lap distance,
- › total distance.

Use the up  and down keys  to scroll through the available items. The selected value is highlighted in the centre in the white line.

Press the power-on key  to confirm and return to the Advanced page.

Select the Back item and press the power-on key  to return to the Advanced page without changing the unit of measure.

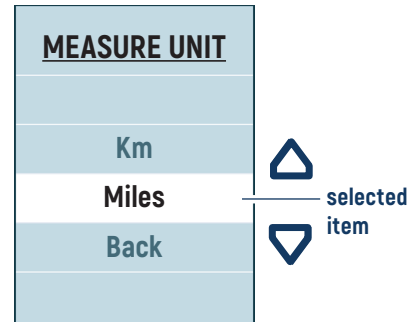

GENERAL INFORMATION

DESCRIPTION

INSTALLATION

USE

HOME

MENU

ADVANCED



TROUBLESHOOTING

MAINTENANCE AND ASSISTANCE

**Weight**



From this screen you can set your body weight by choosing a value between 50 and 150 kg.

 *Setting this datum is not necessary for the eBike to function correctly. The value has the sole purpose of making the calculation of the calories consumed reliable.*

Use the up  and down keys  to scroll through the available items. The selected value is highlighted in the centre in the white line.

Press the power-on key  to confirm and return to the Advanced page.

Select the Back item (located after item 150) and press the power-on key  to return to the Advanced page without changing the weight.



<b>WEIGHT</b>	
68	min 50 Kg
69	
70	selected item
71	
72	max 150 Kg

- GENERAL INFORMATION
- DESCRIPTION
- INSTALLATION
- USE**
- HOME
- MENU
- ADVANCED
- TROUBLESHOOTING
- MAINTENANCE AND ASSISTANCE

## Gender

From this screen you can set your gender.

 *Setting this datum is not necessary for the eBike to function correctly. The value has the sole purpose of making the calculation of the calories consumed reliable.*

Use the up  and down keys  to scroll through the available items. The selected value is highlighted in the centre in the white line.

Press the power-on key  to confirm and return to the Advanced page.

Select the Back item and press the power-on key  to return to the Advanced page without changing the gender.

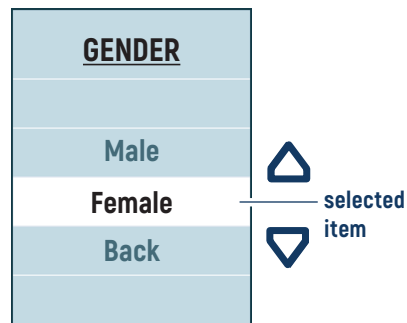





- GENERAL INFORMATION
- DESCRIPTION
- INSTALLATION
- USE**
- HOME
- MENU
- ADVANCED
- TROUBLESHOOTING
- MAINTENANCE AND ASSISTANCE

### Night mode

From this screen you can choose the configuration for night mode:

- › automatic, the night mode is set automatically by means of the twilight sensor inside the display, which detects the ambient brightness;
- › active, night mode always active;
- › deactivated, night mode always deactivated.

Use the up  and down keys  to scroll through the available items. The selected value is highlighted in the centre in the white line.

Press the power-on key  to confirm and return to the Advanced page.

Select the Back item and press the power-on key  to return to the Advanced page without changing the configuration.

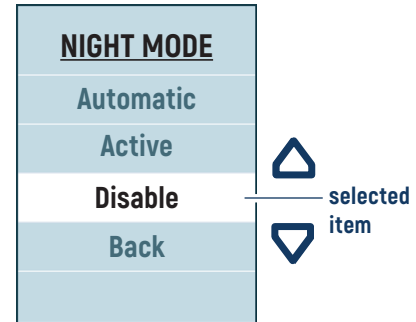

GENERAL INFORMATION

DESCRIPTION

INSTALLATION

USE

**TROUBLESHOOTING**

MAINTENANCE AND ASSISTANCE

**ERROR CODES**

In the event of a fault, the system signals the problem to the user by displaying a danger icon combined with a 4-character code, which allows the user to trace the type of error.

The following table lists the possible faults and the 4-character codes displayed in the error messages.

error	problem	solution
0001	Battery communication problem. Battery status data may be displayed incorrectly.	Check that the battery cables and contacts are intact and connected correctly. Check the cable connections by removing the motor, <i>see the motor user manual</i> .
0101	Communication problem between power unit and HMI.	Check that the wiring is intact and connected correctly. Check the cable connections by removing the motor, <i>see the motor user manual</i> .
0104	Speed sensor not detected.	Check that the speed sensor is installed and connected correctly. Check that the alignment between the magnet and the speed sensor is correct. <i>See motor user manual.</i>

 Depending on the type of fault, the system may prevent the motor from starting or run at reduced power.

 Where "request assistance" is indicated, the intervention of an OLI eBike Systems technician is required.



GENERAL INFORMATION

DESCRIPTION

INSTALLATION

USE

**TROUBLESHOOTING**

MAINTENANCE AND ASSISTANCE

error	problem	solution
0105	Non-compliant torque meter signal. The torque meter signal has a fault. Reduced power operation.	<b>Request assistance.</b>
0106	Non-compliant torque meter offset. The torque meter signal has a fault.	<b>Request assistance.</b>
0801	Motor rotation sensors fault.	<b>Request assistance.</b>
0802	Pedal rotation sensors fault.	<b>Request assistance.</b>
0804	Excessive drive temperature. The temperature sensor inside the drive has detected a temperature above the danger threshold.	Shut down the system temporarily to allow the components to cool. <b>If it occurs frequently, ask for assistance.</b>
0805	Excessive motor temperature. The motor has reached a temperature above the danger threshold.	Shut down the system temporarily to allow the components to cool. <b>If it occurs frequently, ask for assistance.</b>
0806	Non-compliant peripheral bus voltage.	<b>Request assistance.</b>
0808	Locked rotor. The motor failed to start due to a mechanical lock or a problem with the internal wiring of the power unit.	<b>Request assistance.</b>



- GENERAL INFORMATION
- DESCRIPTION
- INSTALLATION
- USE
- TROUBLESHOOTING**
- MAINTENANCE AND ASSISTANCE

error	problem	solution
0809	The battery voltage is higher than the maximum allowed.	Possible battery defect, try alternative or new battery.
<b>0810</b>	Non-compliant current sensor signal.	<b>Request assistance.</b>
<b>0811</b>	The drive has detected an overcurrent.	<b>Request assistance.</b>
1101	Communication problem between power unit and HMI. Check that the wiring is intact and connected correctly.	Check the cable connections by removing the motor, <i>see the motor user manual.</i>
1102	A key on the keypad is stuck in a pushed position.	Try moving the keys on the keypad. <b>If this does not resolve, please request assistance.</b>



GENERAL  
INFORMATION

DESCRIPTION

INSTALLATION

USE

TROUBLESHOOTING

MAINTENANCE AND  
ASSISTANCE

### TECHNICAL ASSISTANCE

Ordinary and extraordinary maintenance must be carried out in accordance with the instructions contained in this manual.

#### Request for assistance

In case of error codes that require assistance *(see "Error codes" on pg. 32)*, problems that could not be solved with the suggested indications, problems not indicated and for any kind of assistance, it is recommended to contact the manufacturer directly.

#### data to be reported in the request for assistance

model *(see identification plate)*

serial number *(see identification plate)*

year of construction *(see identification plate)*

HMI version *(see "System info" on pg. 24)*

motor version *(see "System info" on pg. 24)*

 *The manufacturer declines all responsibility for damage to persons or property, as well as for the faulty operation of the unit, in the event of:*

- > *improper use of the unit;*
- > *errors in use or inexperience, imprudence and negligence with respect to the indications and instructions contained in this manual;*
- > *use of non-original spare parts.*

Correct reference of the data when requesting for assistance guarantees quick and accurate answers.



Tel. +39 0547 318322

customerservice@oli-ebike.com  
info@oli-ebike.com

## GENERAL INFORMATION

## DESCRIPTION

## INSTALLATION

## USE

## TROUBLESHOOTING

## MAINTENANCE AND ASSISTANCE

### CLEANING AND MAINTENANCE

None of the components must be immersed in water or cleaned with a high-pressure jet.

To clean the HMI unit, use a cloth moistened with water.

 **Never use aggressive products or abrasive powders or basic or acidic chemical detergents.**

 *The manufacturer declines all responsibility for damage caused by incorrect cleaning or resulting from the use of unsuitable products.*

### DISPOSAL

 HMI unit, display, keypad, various accessories and packaging must be disposed of in compliance with the environmental regulations in force.

When the unit is put out of service and dismantled, it is necessary to separate the plastic parts and the electrical components, which must be sent to the separate collection centres in compliance with the regulations in force. The metal parts must be separated for correct recycling. Electric and electronic components, marked with a special symbol, must be disposed of in authorized collection centres. Illegal disposal of "Waste Electrical Electronic Equipment" (WEEE) is punished with sanctions regulated by the laws in force on the matter.

Do not dispose of the various components in household waste. Do not throw this product into the fire.

Rechargeable batteries and defective or worn out batteries must be collected separately and sent for ecological reuse.

Return the HMI unit that is no longer functional to an authorized eBike dealer.

 *Disposal operations must be carried out by suitably trained personnel.*



Delete this page in the digital version





**OLI eBike Systems**  
Via delle pesche, 891  
47522 Cesena (FC) Italy



Tel +39 0547 318322  
info@oli-ebike.com  
customerservice@oli-ebike.com



**visit our website**  
[www.oli-ebike.com](http://www.oli-ebike.com)

