

# DEVELON

## Dozers

DD100 / DD130



# DEVELON

## Continuous evolution, for better.

---

We trace our roots to 1937 as one of Korea's first large-scale machine plants. During that time, we have consistently delivered earth-moving equipment to build critical infrastructure for the betterment of communities, societies and the wider world.

We are  
DEVELON.

DEVELON is a bold name that reflects our core ambition to continue developing onward and leaving behind a positive footprint in our world. Moving forward, we will continue providing innovative products and solutions that advance the world we live in today.



# Your Local Dealer Is Dedicated to Your Success.

Your local DEVELON dealer is here for you: helping to solve your unique business challenges and advance the development of your community. Our dealers provide a full lineup of highly productive and fuel-efficient equipment, outstanding value and comprehensive services to help build your success.

## Expanding Equipment Lineup

DEVELON continues to expand our innovative and durable lineup of equipment, providing more of the resources you need to take on a variety of projects and expand your business. Talk with your dealer to find the right equipment, attachments and technologies to move ahead.

## Authorized DEVELON Service Technicians

You can count on experienced and highly skilled professional technicians from your local dealership to keep your valuable DEVELON equipment running at peak performance. You'll get responsive service, reliable parts and trusted advice.

## Parts Availability

With two DEVELON-exclusive parts distribution centers in Georgia and Washington state, your dealer can offer more parts inventory and faster delivery – including less than two-day delivery on a majority of genuine DEVELON parts.

## Machine Assembly Facility

A dedicated facility in Savannah, Georgia, tailors the equipment configuration and final machine assembly for faster delivery to your dealership.



# A Better Dozer Has Arrived.

DEVELON introduces powerful new grading machines to join our tested lineup of durable construction equipment. DEVELON dozers deliver superior horsepower and traction to push more material. Smart technologies and exceptional visibility help operators of all skill levels achieve greater grading precision. A highly durable undercarriage stands up to rugged conditions and lowers maintenance costs.

## More Pushing Power

- Best-in-Class Horsepower (Gross and Net)
- Best-in-Class Weight (DD100 - Base Unit)
- Superior Tractive Effort

## Precise Grading Performance

- Optional 2D Blade Assist Function
- Compatible with Optional 3D Machine Guidance and Machine Control System (DD100)

## Superior Visibility

- Inline Precleaner
- Narrow Front Nose
- Standard Rearview Camera
- Minimized Cab Pillars
- Maximum Glass Area

## Smart Technologies

- Fully Electrohydraulic Controls
- Smart Touch Display
- DEVELON Fleet Management

## Low Maintenance

- Exclusive Undercarriage Design With Dual and Single Flanges
- Cab Tilt System for Convenient Access
- Shared DEVELON Excavator Parts
- Track Guard Options



Awarded to DD100.



Awarded to DD100.

# Never Stop Pushing for More.

DEVELON dozers push the limits of what you can expect from a powerful earthmoving machine – with best-in-class horsepower (gross and net), best-in-class weight (DD100 - base unit) and built-in efficiency features designed for today's toughest grading assignments.

## Superior Pushing Power

DEVELON dozers offer best-in-class horsepower, and the DD100 model has best-in-class weight for more power to the ground and superior tractive effort. This helps you push more material and maximize productivity.

Using the max forward and reverse speeds, you can quickly and easily move from one end of the job site to the other or reposition the machine. Which means you'll get more done.



## Powerful Diesel Engines

Dozer engines deliver the robust power and durability required to take on the most demanding jobs. They're optimized for more power output with reduced fuel consumption and feature Tier 4-compliant diesel engines to reduce emissions.

The DD100 DEVELON D34 diesel engine does not require the use of a diesel particulate filter (DPF) to meet current emissions standards.

## Fuel Efficiency Features

To further improve fuel efficiency without sacrificing grading performance, select the **ECO mode** for light grading conditions and reduce daily fuel consumption up to 5%. The fuel-saving feature lowers the pump power output when working in lower tractive conditions.

To reduce noise, enable job site conversations and reduce fuel consumption, the **auto idle** feature idles the dozer engine automatically when machine functions are not used. Idle time can be set directly from the display monitor. Move the controls and the dozer will automatically return to your previous throttle setting.

The **auto shutdown** feature also saves fuel and helps lower warranty hours. When enabled, the engine shuts down after it has been idling for a specified amount of time. Default shutdown occurs after five minutes of idling, but can be set for longer periods using the Smart Touch display.



## Blade Features

The **6-way power-tilt angle blade** provides more precision pushing capabilities to move and grade dirt, clay and other difficult material. Work more efficiently and reduce the number of passes on each job by lifting, tilting and angling the blade to move dirt or other materials exactly where they need to go.

A **2-way mechanical adjustment** also allows you to adjust the blade pitch to control how steeply it bites into the ground. The DD100 dozer blade pitch

adjusts from 54 – 58 degrees. The DD130 dozer blade pitch adjusts from 52 – 58 degrees. See page 19 for details.

For smooth back grading or fine finishing, select the **blade float function** to enable the blade to move up and down following the contours of the ground.

When grading mucky, clay-like material, use the **blade shake button** to activate a shaking motion to quickly remove material stuck to the blade – without leaving the cab.

# Achieve Greater Grading Precision.

Grading precision is critical but can be challenging if a dozer is difficult to operate. DEVELON dozers deliver easy-to-use controls and advanced grading technologies that help operators of every skill level work efficiently and confidently.



## Fully Electronic Controls

DEVELON dozers are designed to meet the needs of operators of every skill level. Electrohydraulic controls are standard, making the machines easier to operate — even for inexperienced crew members. The ergonomically designed joystick offers low-effort control to help reduce operator fatigue.

The DEVELON dozer cab layout and controls are similar to the DEVELON -7 Series excavators and wheel loaders, making operators more productive as they move from machine to machine throughout the workday.



The user-friendly, multilingual Smart Touch screen — a standard feature — displays all important settings and information on one screen. From the easy-to-read touch screen, operators can monitor critical dozer functions and control machine settings, rearview camera, heating and cooling, radio, Bluetooth® wireless technology and more.



## Optional 2D Blade Assist Function

This optional 2D grading system makes precision grading easier for novice operators. The operator programs the needed inputs, and the machine controls blade functions — finishing the job faster and with better accuracy. No GPS or lasers required.

## Compatible with Optional 3D Machine Guidance and 3D Machine Control System

For greater accuracy and ease of operation, this system can be added to the DD100 model. It reduces operator inputs by up to 80%, activating automatic blade movements based on GPS coordinates to meet critical elevation and slope specifications.

# Keep Pushing in Comfort.

DEVELON dozers are designed with high-traffic job sites, challenging work and long days in mind. Superior visibility and quiet, comfortable cabs help operators make the grade.



## A Leader in Visibility to the Blade

- Visibility was a high priority in the design of DEVELON dozers.
- The narrow design of the front nose hood makes it easier to see your work. The cooling system for the radiator/oil cooler module is hydraulically driven and located at the rear of the machine.
- An in-line precleaner is placed under the hood to provide the operator with a more unobstructed view of the blade.
- Front cab pillars are minimized to reduce obstructions, and all-glass doors result in more glass area — for maximum visibility.

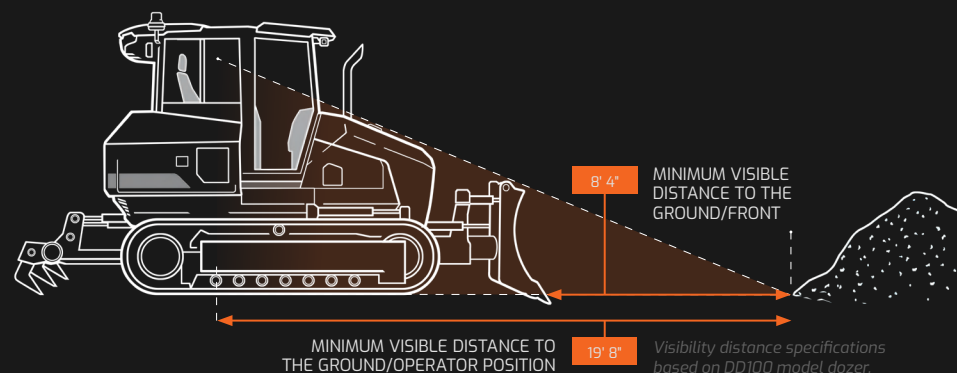

- Standard features include a rearview camera, four high-illumination LED lights and four premium, smooth-glide wiper blades.

## Comfort and Safety Features

The heating and air conditioning system is designed with multiple air vents in the front, rear and floor areas to keep operators comfortable in every season.

The front and door glass defrost vents help improve visibility. The front glass defrost meets EN474 ISO10263 defrost standards.

The cab's suspension system (CabSus mount) dampens vibrations and provides outstanding protection against impact. Driving shock improvements deliver a smoother ride, even when starting and stopping the dozer.

The hands-free audio system allows operators to choose AM/FM, pair and connect a Bluetooth® device, make and answer phone calls using hands-free mode and play audio from a USB device.

A variety of features can help improve the safety of operators on the job, including an Operator Presence Switch (OPS) that stops the machine when the operator stands up, a seatbelt warning alarm and a rotating beacon. Our dozers meet the safety standards of ROPS (Roll Over Protective Structure) and FOPS (Falling Object Protective Structure) requirements.



# DEVELON Durability in a Dozer.

Dozer work can be punishing on machine components. DEVELON dozers are engineered to withstand the most rugged conditions and be easier to maintain — to keep you pushing ahead.



### Exclusive Undercarriage Design

DEVELON developed a unique dozer undercarriage system to help lower the total cost of operation. The undercarriage features sealed and lubricated components, as well as single-and dual-flange rollers, to improve durability and extend component life.

- Dual-flange rollers go outside the chain of the track, and single-flange rollers sit inside the chain of the track. The combination helps ensure that the track stays on the undercarriage, helping to reduce wear and providing greater operator comfort.
- Areas of the undercarriage that naturally experience greater wear and tear are easy to access.

The **oscillating serrated track system**, standard on the DD130, ensures consistent, stable ground contact to improve fine grading performance and operator comfort. The system follows the terrain and enables more precise blade control.

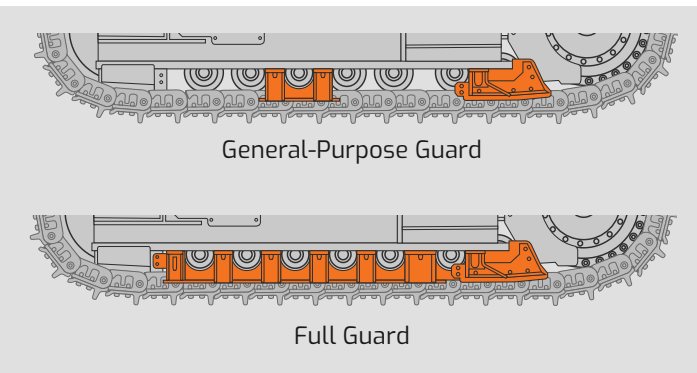

**Two track guard options** are available, general-purpose and full guard, for exceptional performance and uptime protection.

**Trackshoe options** are also available to help distribute the load to the ground, based on job site conditions.

- Thinner tracks are used for rugged, rocky environments.
- A low-ground pressure option is best for sandy soil conditions.



### Easy Maintenance

Regular inspection points are easily accessible at ground level. When maintenance is needed, the dozer cabin tilts up to offer convenient access — there's no need to disassemble the cab to reach critical components.

### Intake System

- A high-efficiency, integrated precleaner helps improve filter life.
- This standard in-line precleaner is integrated with the air cleaner and is more compact to fit in the smaller engine compartment.
- Self-cleaning and maintenance-free, the system can expel all types of mixed debris, including mud, snow, rain, leaves, sawdust and chaff.

### Fuel System

An easily accessible filter-type, high-performance water separator effectively captures moisture in the fuel, reducing impurities and helping eliminate contamination.

- Standard pre-filters and dual main filters achieve a high degree of purity that minimizes fuel system failures.



### Easy Maintenance Access

A centralized grease point at ground level provides one location to grease multiple grease points. Centralized engine filter and hydraulic filter/tank locations are in a secure and protected area.

### Serpentine Belt

The dozer's serpentine belt reduces the number of belts requiring service and inspection.

### Hydraulically Controlled Cooling System

The system offers a reversible fan as a standard feature. Operators can set the fan to automatically reverse at a predetermined time interval.

- The cooling system is located in the rear of the machine instead of in the front. This results in a smaller front engine compartment and improves visibility to the blade.



### Standard Warranty

Full coverage for 12 months or 1,500 hours and powertrain and hydraulic coverage for 36 months or 5,000 hours with parts and service support from your local authorized dealer.

### Extended Warranty

Our Protection Plus® extended warranty coverage offers more than 70 different plan options so you can customize coverage to meet your needs. This coverage protects from deficiencies in materials or workmanship for up to 60 months or 7,500 hours, whichever comes first.



DEVELON Fleet Management > ECO Mode  
> Rearview Camera > Blade Shake >  
Smart Touch Display

## Premium Features Come Standard on DEVELON Dozers.

To compete and succeed, your equipment needs to maximize job site productivity and the bottom line. DEVELON machines do both. To ensure a high return on investment, we add more premium features as standard equipment on every model.

These features are often options that come with an additional cost from other manufacturers. By including them as standard, DEVELON gives you a competitive edge — helping operators work more efficiently and improving safety during the longest workdays.

---

### DEVELON Fleet Management

Power telematics system makes it easy to remotely monitor and maintain your machine. It keeps track of the health, location and productivity of the equipment from a user-friendly app and website.

---

### ECO Mode (Selectable Engine Control)

The ECO mode reduces daily fuel consumption up to 5% without sacrificing grading performance by lowering the pump power output when working in lower tractive conditions.

---

### Rearview Camera

The rearview camera provides the operator with an additional view of the dozer's surroundings, increasing confidence and productivity.

---

### Blade Shake

No need to leave the cab to clear off the blade when working in sticky, clay-like material. A push of the blade shake button activates a shaking motion to quickly remove material stuck to the blade.

---

### Smart Touch Display

An easy-to-read, user-friendly multilingual touch screen displays all important settings and information, including the rearview camera view. Operators can monitor critical dozer functions and control machine settings.



# Monitor Your Equipment From Anywhere.

DEVELON Fleet Management is a powerful equipment diagnostic tool that monitors the health, location and productivity of your DEVELON equipment from a user-friendly mobile app and website.



**Scan the Code**  
Learn more about how DEVELON Fleet Management can help you take care of your valuable DEVELON equipment.

## With DEVELON Fleet Management, You Can:

- Help prevent theft with geofencing feature (GPS location tracking).
- See when maintenance is due.
- Customize alerts to your schedule.
- Track oil pressure, operating temperature and more.
- Use data to train your team for maximum productivity.

The data is uploaded automatically to the DEVELON Fleet Management online system. You can check on your machine status from anywhere using the website and mobile application. Your dealer can also see your equipment status and notify you when it's time for service.

## SMART X-CARE

Let us do the work for you to help protect your equipment investment. DEVELON Smart X-Care™ service gives you peace of mind knowing our experienced team is tracking your machine telematics and providing recommendations. **Talk to your dealer to learn more.**

# Attachments

Dozer attachments bring added versatility to the job and are built to DEVELON machine specifications for superior reliability and performance.



Parallel 3-Shank Ripper Attachment

The DEVELON dozer includes piping for an optional parallel 3-shank ripper attachment, making it easy to add. The ripper attachment features parallel linkage that helps maintain a constant angle to the ground regardless of the height. The ripper attachment helps to quickly break up hard, rugged materials prior to grading.



Towing Draw Bar Attachment

Adding a towing draw bar attachment enables you to use your dozer for towing other equipment around the job site.



Two Blade Options

Choose from a standard (XL) blade or a low-ground pressure (LGP) configuration. See model spec sheets for blade capacity details.

## Blade Tilt

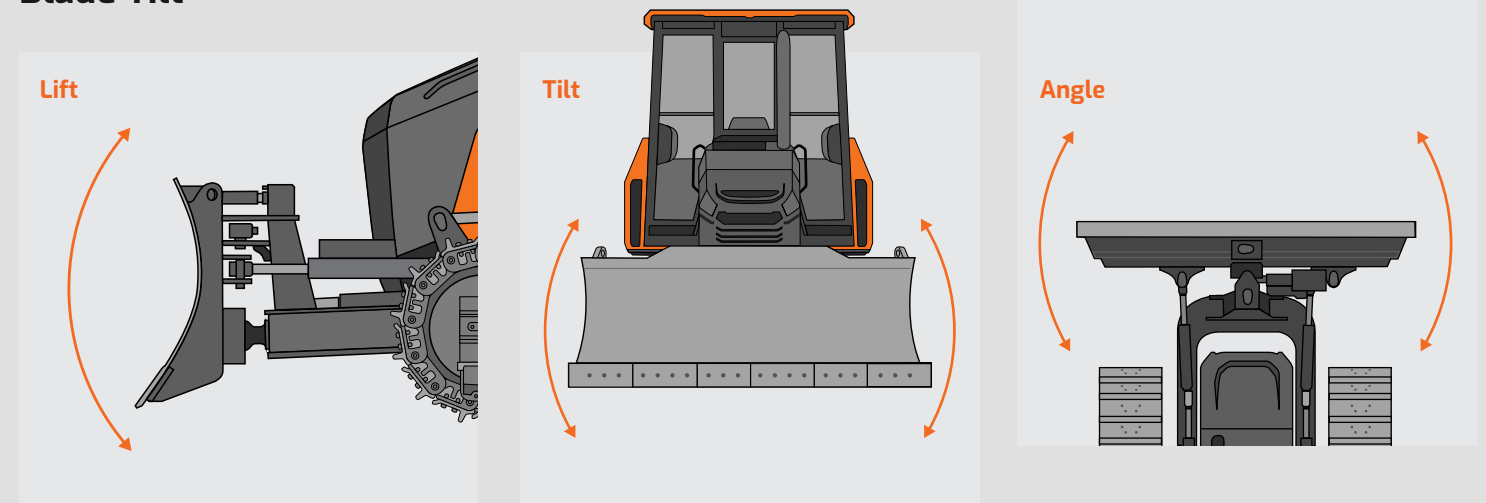

Certain specification(s) are based on engineering calculations and are not actual measurements. Specification(s) are provided for comparison purposes only and are subject to change without notice. Specification(s) for your individual DEVELON equipment will vary based on normal variations in design, manufacturing, operating conditions, and other factors. Pictures of DEVELON units may show other than standard equipment.

# Powered by Innovation

# DEVELON

A brand of HD Hyundai Infracore.

[na.develon-ce.com/dozer](http://na.develon-ce.com/dozer)

Dozer Brochure  
Printed in the U.S.A.  
23910\_003\_D091523

©2023 HD Hyundai Infracore. All rights reserved.