



## **ETRIKE OWNER'S MANUAL**



*GENERATING PURE EXCITEMENT*

We can't thank you enough for choosing to purchase an electric e-bike from Kasen Electric Bicycles. Our mission is to make sure our customers get the utmost enjoyment out of their e-bikes and enjoy them safely.

We hope you'll have a great riding experience on your new e-bike. If you decide to snap some photos of you and your e-bike on your adventures, we'd love to add them to our website's photo gallery. You can email photos to [KasenBikeCustomerService@gmail.com](mailto:KasenBikeCustomerService@gmail.com) or tag us on Instagram by adding the hashtag #Kasenbikes.

If you need to contact us for any reason, feel free to reach us by mail, email or phone at the contact address listed below.

Our hours are as follows:

Monday-Friday: 9 AM – 5 PM (Pacific)

Kasen Electric Bicycles  
4560 Eucalyptus Ave. Unit A  
Chino CA 91710  
Technical Support:  
[KasenBikeCustomerService@gmail.com](mailto:KasenBikeCustomerService@gmail.com)  
Phone: 800.680.6698

## BEFORE YOU RIDE YOUR KASEN ETRIKE

Please carefully read the following information.

- User assumes all risks when using the Kasen eTrike e-bike. Read all instructions and warnings before use! If you have any questions about any instructions in this manual and the e-bike, please contact us at [KasenBikeCustomerService@gmail.com](mailto:KasenBikeCustomerService@gmail.com)
- Please provide this manual to the local e-bike mechanic as needed for any work needed on the e-bike.
- This e-bike is intended to be used as described on the product page for the respective model.
  - It is intended to be used as a bicycle and not intended for interstate, ATV, offroad, or other use not intended for a bicycle of this model.
  - This e-bike is not intended to be used as a replacement or substitute for a motorcycle.
  - This e-bike is not intended to be used for jumps, drops, or extreme riding and/or terrain.
  - Any of the above such non-intended use, and other forms not listed herein, may void the warranty with the product and could subject the rider to serious harm, injury, and/or death.
- Before riding, please learn about your local electric e-bike regulations, including speed limits, surfaces, and areas allowed, and ensure to meet your local requirements when riding.

- The e-bike is not meant to be towed behind a vehicle or any other product or system, motorized or not.
- This Kasen Electric Bicycle is designed with a 21mph speed limit when using pedal assist (PAS), and 21mph on throttle assist only. Users assume all responsibility and liability for using the e-bike either with electric assistance or under the rider's own power beyond 21 mph. The User's responsibility is to ensure that the e-bike's maximum speed meets all local rules and regulations. Changing the top speed of the e-bike is not recommended.
- Only use with one rider at a time.
- Check the e-bike and all related products before each use to confirm proper assembly and that it is in working order
- Check the e-bike and all related products after a crash to ensure it is still safe to operate or needs repair or replacement.
- If the e-bike and all related parts are not in operable condition or you think something is wrong with the product, do not use it. If there is something wrong with the product that cannot be fixed, please contact Kasen Electric Bicycles.
- Kasen Electric Bicycles accept no responsibility or liability for any injury or damage resulting from improper use of our e-bikes or accessories by rider/user. Further, Kasen Electric Bicycles accepts no liability due to incorrect use instructions provided by the e-bike owner to other users.

## RIDING TIPS

- **Maximum weight:** 350 pounds (including rider.)

**Age requirements:** This e-bike is not intended for use by minors or children. Any use of the e-bike in this manner should be done under constant parental supervision after the e-bike's systems, including the electric motor, acceleration, and braking, have been clearly explained. Kasen Electric Bicycles accept no liability in event of injury or death caused under such conditions.

- Abilities – Using this product requires basic riding abilities and using motorized vehicles. Such skills can be learned with this product, but care should be taken. It is recommended that any user know how to ride a bicycle before riding a Kasen Electric Bicycle.
  - Riding a bike that has a long wheelbase and can carry cargo will take getting used to. Practice maneuvering and braking on a flat, hazard and traffic-free area with and without cargo before going out into the world. Carrying heavy cargo involves risks, foremost of which can be decreased braking power and increased stopping distance.
- Medical limitations – Do not use if you have an existing medical condition, injury, or other limitation which could affect your balance or an ability to ride an e-bike. Do not participate activities that can endanger your health and safety. Kasen Electric Bicycles accept no liability in event of injury or death caused under such conditions.
- Usage limitations - This e-bike should be usable almost anywhere a regular bike can be. You and users should be aware of any local rules and regulations regarding motorized transportation. If you

or the users have questions, check with local authorities and the local rules and regulations before riding your Kasen Electric Bicycle.

- Weather – Your e-bike is designed to be water-resistant to rain and snow. It is not designed to be subjected to prolonged heavy rainfall or subjected to the increased water pressure that occurs when transporting an e-bike on a car or truck during rain or snow. Please protect your display from rain when transporting by car or truck.
- When riding on roads and streets, always follow all traffic laws for bicycles, including speed limits, unless otherwise advised by local authorities.
- Transporting e-bikes: It is important to check e-bike rack weight restrictions prior to transporting using a traditional e-bike rack. Weight limits on bike racks are often not compatible with the heavier weight of electric bicycles. As a result, special electric e-bike racks are often required for safe transport. Please follow all instructions on your e-bike rack or other racks you choose for safe transport.
- Safety Equipment and Gear: User should always wear a helmet when riding an e-bike, including on city surfaces in traffic or trails. In addition to a helmet, User should wear clothing appropriate and, in preparation for, the weather. When riding in urban settings, particularly at night, User should wear bright and/or reflective clothing to increase visibility to drivers.

## **RIDING INSTRUCTIONS**

- Check the e-bike before every use to make sure the e-bike and components, including, but not limited to, that wheels are secure, brakes work, and the frame is solid, to confirm they are in working order.
- Check battery level before every use to confirm it is charged.

### **General Components and use:**

- Handlebars:
  - Right side: Rear Brake Lever and Gear Shifter.
  - Center: Full-Color Backlit Display.
  - Left side: Front Brake Lever, Thumb Throttle, Display Controls & Bell.
- Acceleration: The e-bike can be accelerated via regular pedal motion and via electric motor by using the throttle.
  - When starting from a stop, pedal the bike first, then engage the thumb throttle. Failure to do so may damage the motor.
  - When riding the e-bike up steep grades for extended periods of time, use the Pedal Assist (PAS) and avoid using the Thumb Throttle. Failure to do so may damage electrical components and the motor.
- Braking: It is recommended that the Rear Brake is the primary brake used, with the Front Brake being a secondary and support brake. Rider should not depress Front Brake Lever only or at high speeds, as an accident and serious injury could occur. The brakes on your electric e-bike include an automatic motor cut-off, which

means the motor power will be shut off when the brake levers are depressed.

- **Body Position:** First, you should have an e-bike in the size that correctly matches and is appropriate to your body size (primarily by height). The ideal body positioning is:
  - Saddle at a height where you can fully reach the pedals but not where your legs are cramped.
  - When leaning forward, you can reach and control the handlebars, including steering the e-bike.
    - When climbing, you may have to lean forward and stand up on the pedals.
    - When descending, you may have to shift your body weight backwards.
    - You need to make sure all these maneuvers are possible so you can safely maintain control of the e-bike.
- **Speed and Abilities:** As you ride more you may become more comfortable with the e-bike at higher speeds and over challenging terrain. Please ride within your limits. You agree not to hold Kasen Electric Bicycles liable for any injuries incurred due to riding above and beyond your limits and terrain abilities and speed.



## **SAFE STARTING & STOPPING**

Remember that if pedal assist is turned on, the motor will turn on and begin to push you forward anytime the pedals rotate (even if you rotate the pedals unintentionally.) This could be unsafe if you weren't expecting the motor to turn on.

To prevent accidentally engaging the motor on your e-bike, you should turn off pedal assist (by setting the display to level zero) when you are not using it.

The motor interrupt brake levers on Kasen e-bikes stop the motor from running when they are squeezed. This adds an additional measure of safety - when you are sitting on the bike but not moving (for example, when stopped at a stoplight), get into the habit of squeezing the brake levers. This habit stops you from accidentally engaging the motor. Release the brake levers when you begin riding and intend to use pedal assist again.

The motor interrupt brake levers can also control your speed in areas where pedal assist is not desired. For example, if you are riding at slow speed through a pedestrian mall, you can pedal to propel the bike forward while simultaneously lightly dragging the brakes. This allows you to ride without the motor turning on at all.

To prevent accidentally engaging the motor when you're done riding your bike, power it off. Never leave your e-bike powered on when parking, hanging from a hook in the garage, or while loading your e-bike onto a car or truck rack for transport.

If your e-bike ever needs repairs or maintenance (for example, fixing a flat tire), always completely power down the e-bike before starting work.

## **BATTERY AND CHARGING**

The eTrike uses a Lithium-Ion battery, which can be charged either on or off the bike. We recommend charging the battery indoors, in moderate temperature conditions. To charge the battery, plug the charger into the charging port and then connect it to a wall outlet. The LED indicator light will be red when charging and will turn green when charging is complete. When finished, unplug the charger from the wall outlet.

Taking proper care of the battery will ensure a long service life:

- Charge and store the battery indoors whenever possible. The battery can be removed from the bicycle for this purpose.
- Avoid extreme hot and cold temperatures.
- DO NOT submerge your bike or any of the components in water. This action will void the warranty.

To optimize the battery's performance over time, do your best to use it (discharging and charging) at least monthly. If you won't be riding your eTrike for an extended period, it's best to store the battery fully charged. The lifespan of the battery is about 1000 charge/discharge cycles. Battery capacity will reduce range and runtime over time. Replacement batteries are available from Kasen to extend the life of your e-bike.

When you install the battery on the eTrike, lock it into place with the supplied key. To remove the battery, pull the lever located under the saddle upwards and flip the saddle forwards. Turn the key on the left side of the battery to the unlock position. Pull the handle, then gently lift the battery out of its mount. Do not ride the bicycle if the battery rattles or moves - it should be firmly attached.

## **ADJUSTING THE SUSPENSION FORK**

The eTrike features a mechanical suspension fork to help you ride with more comfort and control. You can use this adjustment to customize your riding experience.

### **LOCKOUT**

The lockout knob is located on top of the right (from the rider's perspective) side of the fork crown. Engaging the lockout stops the fork from moving at all. This is useful on smooth roads or extended uphill pavement when no suspension is needed. If you find the fork movement undesirable for the conditions, turn the knob counter-clockwise to engage the lockout. Turn the knob clockwise to disengage the lockout when done. Avoid riding the bike on rough terrain with the lockout engaged.

## MAINTENANCE AND SERVICE

Properly maintaining your eTrike ensures its longevity and smooth operation. Before assembling your bike, please watch the "How To Assemble" video we've prepared for you. If you have questions during the assembly process, please contact Kasen at (909) 393-3799 or email [KasenBikeCustomerService@gmail.com](mailto:KasenBikeCustomerService@gmail.com)

Once you're up and running, please make sure:

- When cleaning your e-bike, use a damp cloth and gentle dish soap.  
*Note: DO NOT use a pressure washer or sprayer.*
- Periodically apply a light bicycle lubricant to moving parts, including the chain, derailleur pivots, and shifter cable inner wire where it enters the cable housing.
- If you ride in wet or humid environments, clean and dry electric connections and apply an anti-corrosive substance.

All bicycles will need a periodic tune-up or adjustments by a professional. An annual "check-up" is beneficial. Your bike's service schedule will depend on the frequency of its use. In between expert services at a bike shop, we suggest:

- Keep tires inflated to their recommended pressure found on the sidewall and check weekly.
- Clean the drivetrain and lubricate the chain (monthly)

For more information about further recommended maintenance, we suggest the excellent video series offered by Park Tool on YouTube.

## **SAFETY**

You should wear an approved bicycle helmet every time you ride a bicycle, regardless of the legal requirement to do so. Additionally, some jurisdictions require helmet use when riding Class II e-bikes like the eTrike. You should comply with local law when riding your Kasen bicycle.

Your eTrike comes with reflectors and an LED reflective taillight; we encourage you not to remove them. You should use the front and rear lights when riding in dim or dark conditions.

Some jurisdictions restrict where e-bikes can and cannot be ridden. These limits may include specific speeds and motor wattages. Your eTrike is a Class II e-bike, 500 watts with pedal assist up to 21 MPH and throttle up to 21 MPH. You should only ride it where it's legal and safe.

Your eTrike will run without the throttle plugged in. You can remove the throttle to comply with local regulations if needed.

## **TROUBLESHOOTING**

Having trouble with your eTrike? Most problems are easy to correct.

1. Start by making sure you have a charged battery. You may wish to leave the battery on the charger overnight to ensure a 100% charge before troubleshooting.
2. If your bike's motor will not engage or only engages intermittently, double-check the cable connection where the rear wheel motor plugs into the rest of the system. To function correctly, this connector must be firmly and fully plugged in. If necessary, loosen the clips holding the cable to the frame to create additional slack in the cable, then re-tighten the clips after the motor cable is firmly plugged in.
3. If you bent the derailleur hanger on your eTrike in a fall, don't worry. It's actually designed to fail, sparing damage to the more expensive frame, and is inexpensive to replace for this reason. If you need more, they are available on [Kasen.com](http://Kasen.com) or at partner bike shops.
4. If your bike powers up normally and shows no error messages but will not run when you turn the pedal assist on, check to ensure the cadence (PAS) sensor under the crank arm is plugged in.

## BATTERY TROUBLESHOOTING

Your e-bike battery uses several sophisticated monitoring systems to prevent damage from overcharging, overheating, deep battery discharge, charging with the wrong voltage, and other errors.

Please use the specific charger supplied with your bike. Other chargers may not supply the correct voltage required for charging. Even if another charger has the required voltage, it may not be programmed to initiate the charge cycle. To resolve this:

1. Remove the battery from the bike.
2. Plug the charging tip into the battery.
3. Plug the charger into wall power.
4. Tap the power button on the battery once to turn it on.
5. Charge the battery overnight.
6. When charging is complete, put the battery back on the bike and check for proper operation.

If a situation occurs that could damage the battery, the battery can go into a protective "sleep mode" - the battery cells inside are OK, but the battery won't turn on and won't take a charge. To "wake up" the battery, please follow this procedure:

1. Put the battery on the bike.
2. Plug the charging tip into the battery.
3. Plug the charger into wall power.
4. Tap the power button on the battery once to turn it on.
5. Press and hold **M** on the controls to turn on the display.
6. Allow the battery to charge overnight.

7. Once charged, remove from wall power and check for proper operation.

Under specific circumstances, you might see one single LED flashing constantly on the battery. One blinking LED is a warning of excessive strain on the battery for its charge level. To correct this issue:

- Reduce the strain on the battery and charge the battery. If it will not take a charge, please take the previous steps to resolve the issue.



## **WARRANTY AND SUPPORT**

Kasen warrants the electrical components (Controller, Motor, Display, Battery, & Charger) of each e-bike against defects in workmanship and materials for 365 days from the date of purchase. Proof of purchase is required for any claim. This warranty does not apply to normal wear and tear, improper assembly, improper or lack of maintenance, incorrect usage of parts or incorrect parts used on the bicycle, damage or failure due to impact from accident, abuse, negligence in use, and labor charge on any replacement components.

The User assumes all inherent risks in the use of the product, including but not limited to personal injury, property damage and/or other losses. If you have any warranty/parts inquiries, please contact our customer service email at [\*\*KasenBikeCustomerService@gmail.com\*\*](mailto:KasenBikeCustomerService@gmail.com) or call us at: (909) 393-3977 to diagnose and repair your Kasen Electric Bicycle.

This is an integrated and final statement of Kasen Electric Bicycles limited warranty. Kasen Electric Bicycles does not authorize or allow anyone to extend any other warranties, express or implied. This warranty is expressly limited to the repair or replacement of a defective item, and said repair or replacement is the sole remedy of the warranty. Kasen Electric Bicycles' liability under this limited warranty shall be no greater than the amount of the original components, and in no event shall Kasen Electric Bicycles be liable for incidental or consequential damages.





---

**Product** TFT LCD Display

**Mode** APT TFT750C

**Abbreviation** 750C

---



## 1 . Product Name

- ☰ TFT LCD display
- ☰ Model: APT TFT 750C

## 2 . Electrical Parameters

- ☰ 3.2inch IPS screen
- ☰ 24V/36V/48V/52V battery supply
- ☰ Rated operating current : 40mA
- ☰ Off leakage current < 1uA
- ☰ Max output current to controller : 100mA
- ☰ Operating temperature: -20~70℃, Storage temperature : -30~80℃

## 3 . Dimensions & Material

- ☰ Product shell is ABS, transparent window is made with high strength Acrylic.
- ☰ Dimensions : host/L110mm\*W68.2mm\*H68mm



## 4. Features

- ☰ Suitable for low temperature, Max -20℃.

- ☰ High-contrast 3.2inch IPS colorful matrix screen.
- ☰ Ergonomic external button design, easy to operate.
- ☰ **Speed display:** AVG SPEED, MAX SPEED, SPEED (Real-time).
- ☰ **Kilometer / Mile:** Can be set according to customers' habits.
- ☰ **Smart battery indicator:** Provide a reliable battery indicator.
- ☰ **9-level Assist :** 3-level/5-level/9-level /**UBE (6-level)** optional.
- ☰ **Mileage indicator:** Odometer/ Trip distance/ Clock/ Riding time/ Range.
- ☰ **Power indicator:** real time power indicator, digital or analog.
- ☰ **Error code indicator.**
- ☰ **Software upgraded:** Software can be upgraded through UART.

## 5 . TFT screen instructions

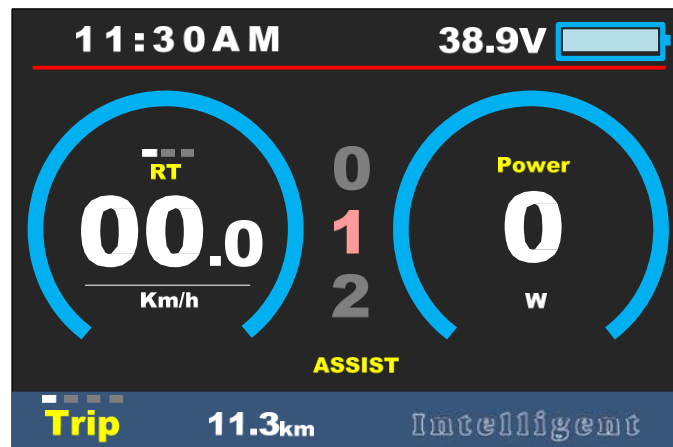

## 6 . Functional Description

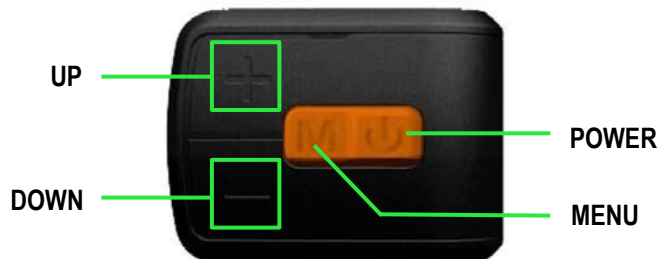

### 6.1 Power On/Off

Press and hold **Power** button for 1 second can turn on/off the display. The Display can automatically shut down when there is no operate & ride for X minutes ( X could be

0~9 ) .

\*If the display has been set password power on, you need to input the right password before start.

## 6.2 Assist level operating

Short press **UP/DOWN** button can change the assist level. Top assist level is 9, 0 for neutral. Level quantities can be adjusted according to the customer requirements.

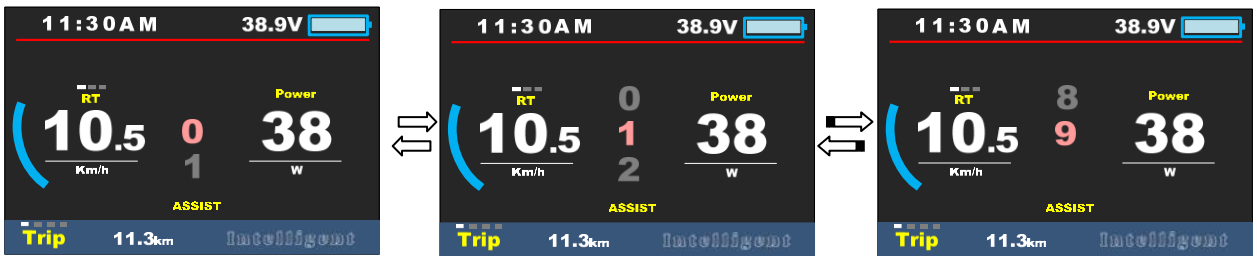

## 6.3 Speed mode switch

Short press **MENU** button can change the speed mode, **Speed**->**AVG Speed**->**MAX Speed**.

\*If there is no operation for 5 seconds, display will return Speed (Real-Time) display automatically.

## 6.4 Mileage mode switch

Short press **POWER** button can change the mileage mode, Trip->ODO-> Time->Range.

## 6.5 Headlight/backlight On/Off

Press and hold **UP** button for 1 second can turn on/off the headlight, and the screen will switch to the corresponding mode.

\*The motor does not work when the battery voltage is low, Display still can keep the headlight on for a while when E-bike is in riding.

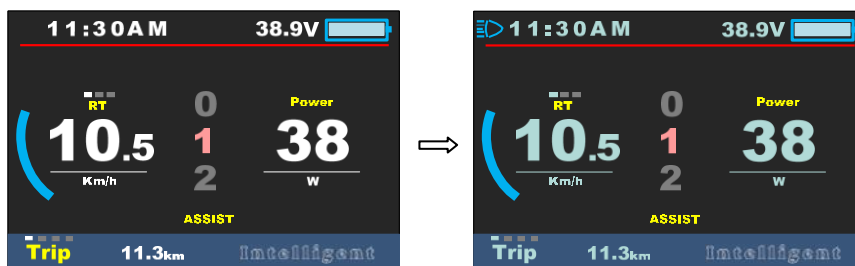

Daytime mode

night mode

## 6.6 Walking mode (6km)

Press and hold **DOWN** button for 2 second can get into walking mode, out of the mode when release the button.

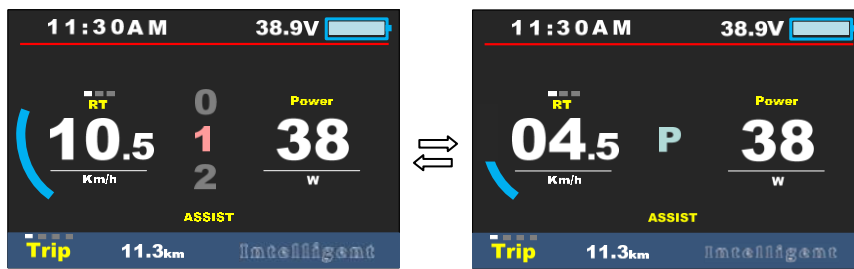

\* This feature needs to be supported by controller.

## 6.7 Data cleanup

Press and hold **UP** & **DOWN** buttons together for 1 second can reset several temporary data, temporary data include **AVG Speed / MAX Speed / Trip / Time**.

\* These temporary data can't be erased by power off.

## 7 . Parameter setting

Double press **MENU** button (press interval less than 0.3 second) can get into setting menus, press **POWER** button to change **Display Setting / Basic setting**, press **UP/DOWN** buttons to change the parameter setting, press **MENU** button can switch to next item. Double press **MENU** button will exit from menu.

\* Display will automatically quit menu when there is no operation for 30 seconds.

\* For safety reasons, display can't get into MENU when riding.

\* Display will quit MENU when start riding.

The order of parameters are as follow.

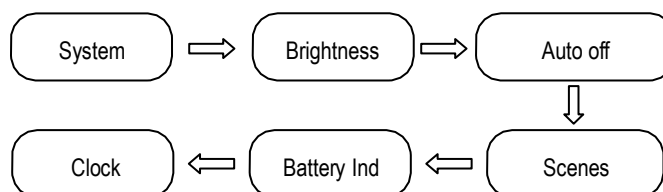

**8.1 System** : Press Up / Down button to switch between Metric / Imperial.

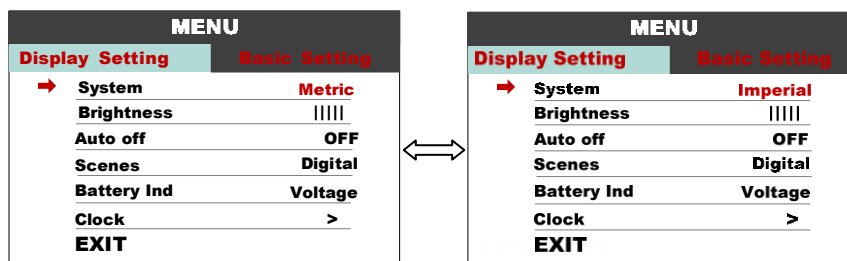

**7.2 Brightness** : Press Up / Down button to change the brightness of the backlight, | is

darkness,  is brightness

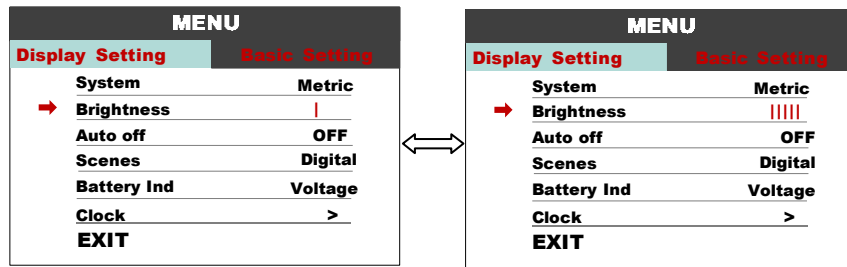

**7.3 Auto off :** Press UP/DOWN button to change the auto power off time, from 1 to 9, the number represent time (minutes) to shutdown, default value is 5 minutes.

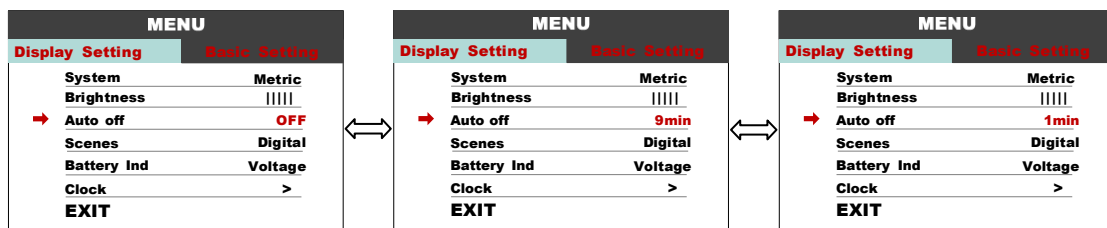

**7.4 Scenes:** Press UP/DOWN button to change the scenes, Digital / Analog.

\*Display only support Analog scenes for now, Digital scenes will be supported for future.

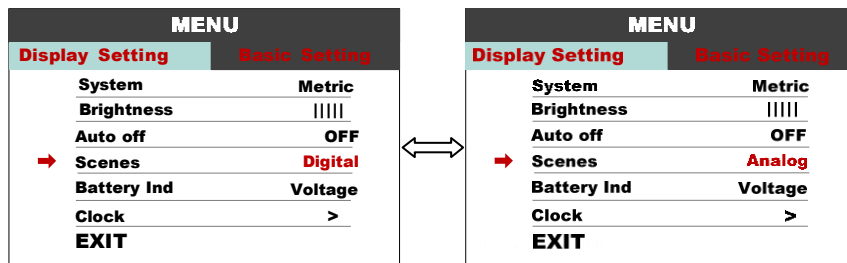

**7.5 Battery Ind :** Press UP/DOWN button to change the battery indicator, Voltage / Percentage / OFF.

\*Accurate percentage needs communication with battery.

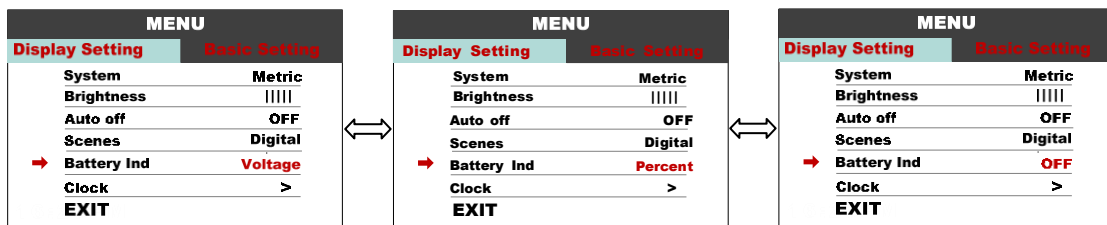



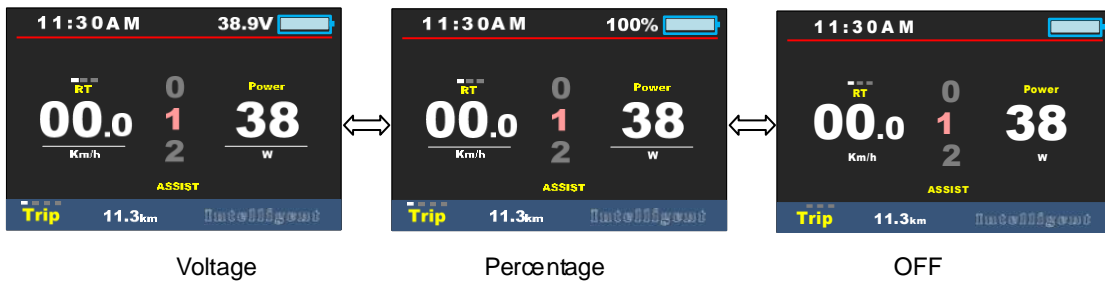

**7.6 Clock** : Clock setting, press **MENU** button get into the clock setting menu, press UP/DOWN button to set Year/Month/Day/Hour/Min/Sec.

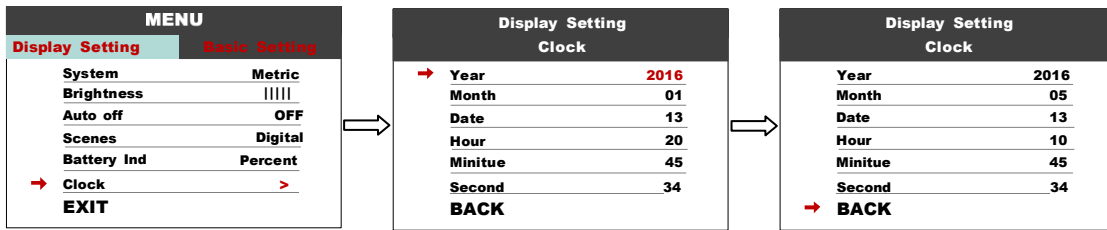

### Basic Setting

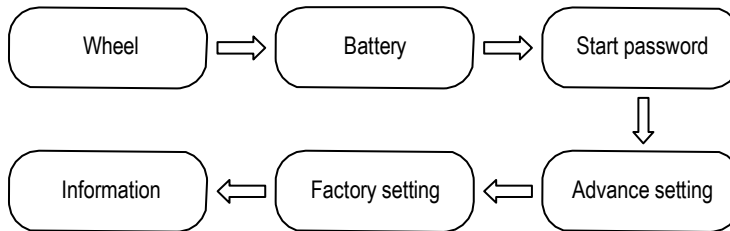

**7.7 Wheel** : Press UP/DOWN can change the wheel setting, optional wheel diameter is [12/14/16/18/20/22/24/26/27/26.5/28/29/30/31](#) inch, 51cm~255cm represent wheel circumference (this needs controller support).

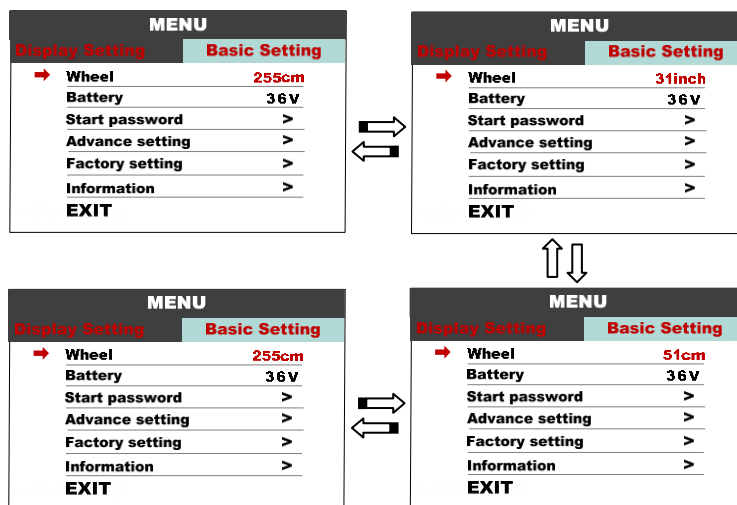

**7.8 Battery** : Press UP/DOWN will change battery voltage setting, optional value is

24V/36V/48V/UBE , UBE means user define value.

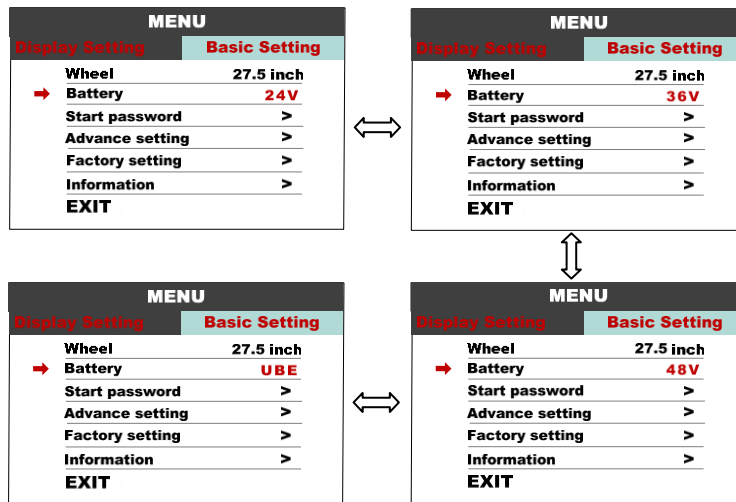

**7.9 Start password :** Press **MENU** button get into the password setting menu. If you had set Start input **ON**, you must input right password before power on, password is accorded to your setting.

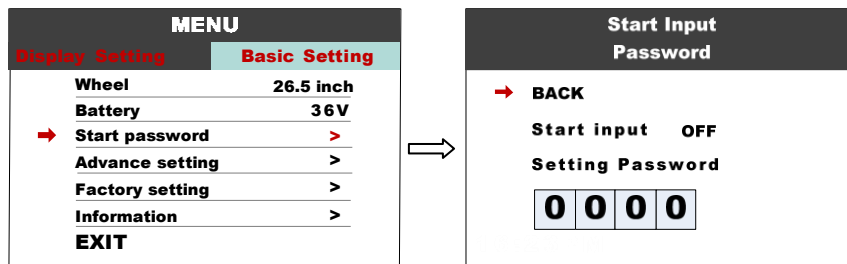

You need to input the right password before start with 30 seconds, display will power off automatically if the password was wrong three times.

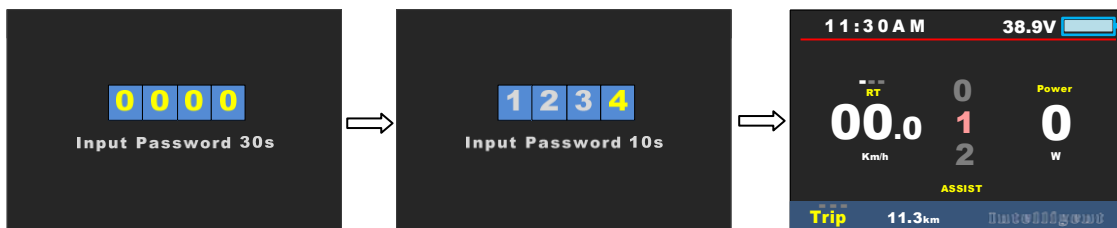

**7.10 Advance setting:** Press **MENU** button can get into the advance setting menu,

default password is '1919'.

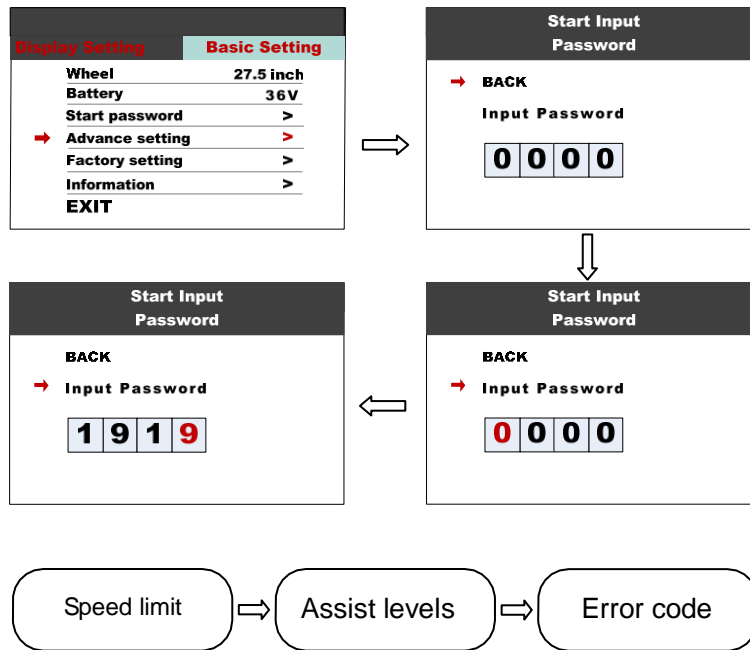

**7.11 Speed limit:** Press UP/DOWN will change speed limit, range 10km/h~60km/h. Default value is 25km/h.

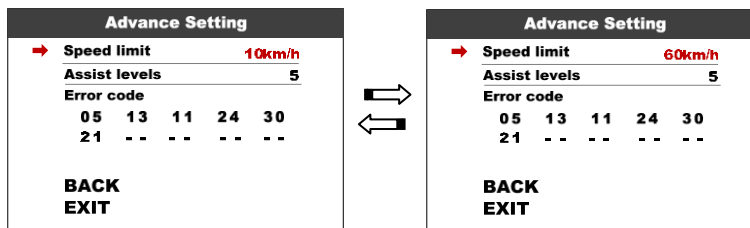

**7.12 Assist levels:** This parameter can customize assist levels, options are 3/5/9/UBE, UBE represent factory default settings.

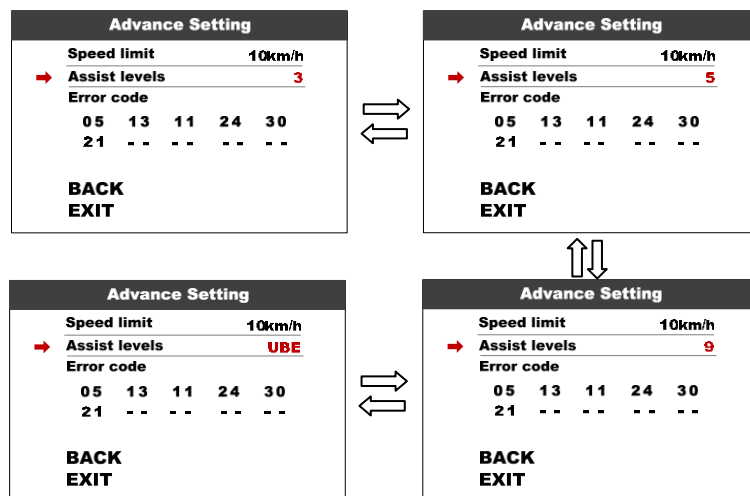

**7.13 Factory setting:** Press **MENU** button enter Restore Factory Settings item, set YES will restore all parameter to factory settings.

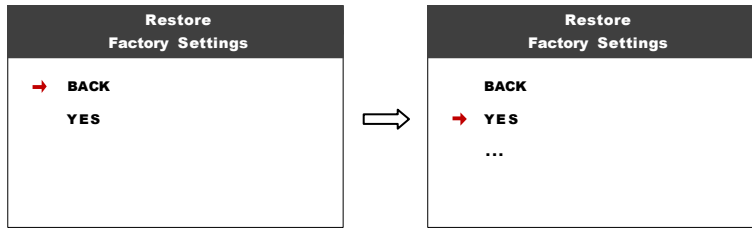

**7.14 Information:** Show information of the E-bike.

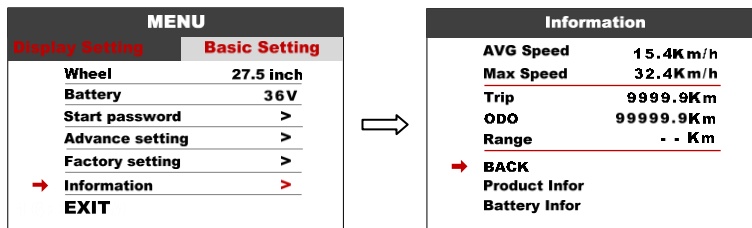

**7.15 Product info:** Get into this item can show hardware version software version...

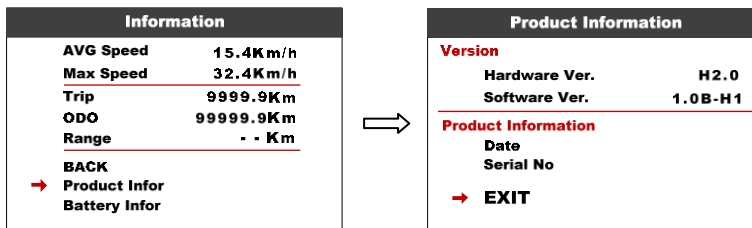

**7.16 Battery info :** Get into this item can show all information of battery, including Voltage, Capacity, Cycle times, Health, Temperature of battery, Remaining Capacity, Full Charge Capacity.

\*These information needs to be supported by battery communication.

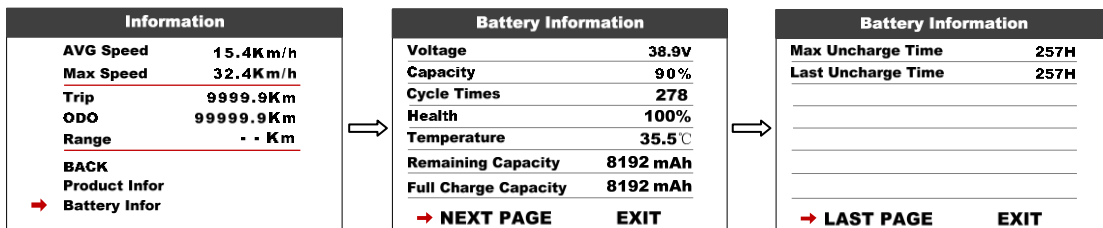

## 8 . Error Code define

750C can show warning message,  icon shows on the screen, and show error code at the bottom of the screen, error code from 01~30, definition see the table below.

Error Code	Error description	Handle
0x04	Throttle turn back fault	Check turn to connect.
0x05	Throttle error	Check turn to connect.
0x06	Under voltage protection	Charge the battery
0x07	Overvoltage protection	Charge the battery
0x08	Hall error	Check the hall connection
0x09	three-phase power error	Check three-phase power line connection
0x10	The controller is overheated	Stop using 10 minutes to restart
0x11	Motor overheating	Stop using 10 minutes to restart
0x12	Sensor error	Check the sensor connection
0x13	battery temperature abnormality	Stop using 10 minutes to restart
0x14	Motor temperature sensor is abnormal	Check the sensor
0x15	Controller temperature sensor failure	Check the sensor
0x21	Speed sensor fault	Check the sensor
0x22	BMS Communication Error	Check the cable connection
0x23	Headlight error	Check the cable connection
0x24	Headlight sensor error	Check the cable connection
0x25	Torque signal error	Contact the supplier
0x26	Torque sensor speed error	Contact the supplier
0x30	Communication Error	Check the cable connection

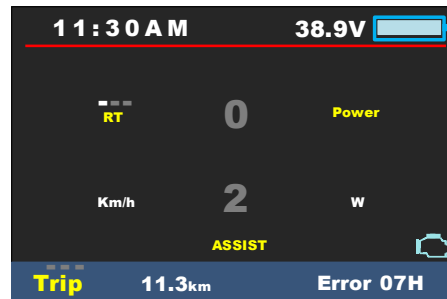
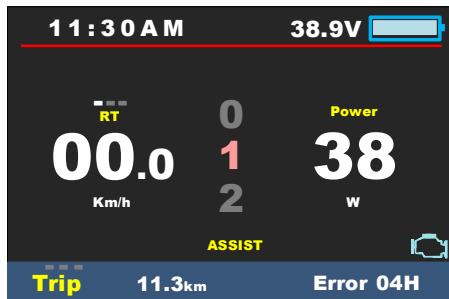

## 9 . Assembly instructions

Please pay attention to the screw's torque value, damaged caused by excessive torque is not within the scope of the warranty.

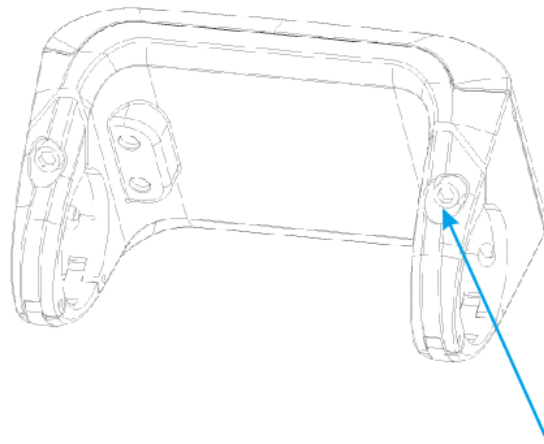

M4\*10  
STD=0.1N.M  
MAX=0.2NM



M3\*8  
STD=0.25N.M  
MAX=0.4N.M

Clamps suit for 3 size of handlebar, 31.8mm, 25.4mm, 22.2mm, there are transfer rings for 25.4mm and 22.2mm (marked with L or R), transfer ring must be assembled with the special directions, pay attention to the green arrow below.

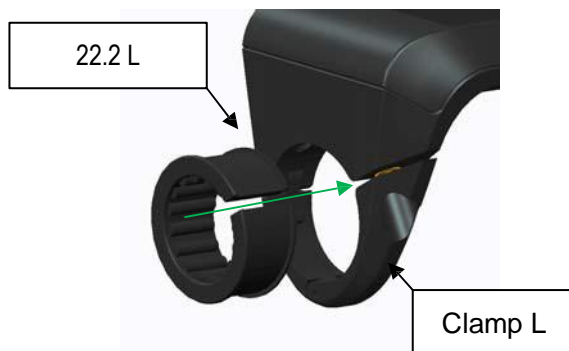

## 10 . Connector descriptions

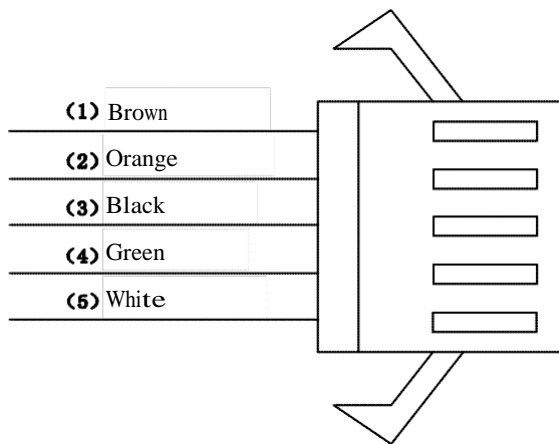

- 1、 Brown wire : Anode(24v/36v/48V/52V)
- 2、 Orange wire : Power cord to the controller
- 3、 Black wire : GND
- 4、 Green wire : RxD (controller -> display)
- 5、 White wire : TxD (display -> controller)

## 11 . Assist level instructions

Assist level can be customized, the highest level is 9, common used assist level see the table below:

3 level	5 level	9 level	UBE (6level)	
0	0	0	0	No power assist
		1	1	
	1	2		
1		3	2	
	2	4		
2		5	3	
	3	6		
		7	4	
	4	8	5	
3	5	9	6	

## 12 . Certification

CE / IP65 (water proof) / ROHS.



**KASEN**

Electric Bicycle