

ET20

Tracked Conventional Tail Excavators



**WACKER
NEUSON**
all it takes!



The evolution of your working world.

Wacker Neuson sets new standards for compact excavators with its new generation of models in the 1.7 through 2.4 t class. Tried and tested innovations are retained and combined with completely new development approaches. The result: A comprehensively renewed machine class right down to the finest details, which promises greater efficiency and performance.

- Innovative, newly designed cab: The redeveloped cab of the ET range sets new standards in terms of clear layout, safety and user comfort with its completely redesigned interior.
- Powerful and efficient performance: The big diesel engines and new, innovative hydraulic system set new standards of operation.
- Maximum connection facilities with up to 4 auxiliary control circuits: Up to 4 additional control circuit options are available ex-works for all models of the ET range.
- Every ET model has its own, optimized undercarriage to guarantee maximum stability and superior drive characteristics in tough everyday conditions.

- Every ET model has its own, optimized boom system with different dipper stick lengths: Thanks to the strong boom system with a choice of two optional dipper stick lengths, every machine achieves maximum digging strength and excavation values.

ET20 Technical specifications

Operating data

Shipping weight min.	1,862 kg
Operating weight	2,005 - 2,324 kg
Biting force max.	12.5 kN
Breakout force max.	18.8 kN
Digging depth max.	2,683 mm
Dumping height	2,713 - 2,836 mm
Digging radius max.	4,317 mm
L x W x H	4,049 x 990 x 2,295 mm

Engine / Motor

Engine / Motor manufacturer	Yanmar
Engine / Motor type	3TNV76
Engine / Motor	Water-cooled 3-cylinder diesel engine
Displacement	1,116 cm ³
RPM / speed	2,200 rpm
Engine performance acc. to ISO	13.2 kW
Battery Voltage	44 Ah
Fuel tank capacity	24 l

Hydraulic system

Duty pump	Double variable pump
Max. flow rate	23.8 + 23.8 l/min
Duty pump	Gear pump
Max. flow rate	19.1 + 6.5 l/min
Operating pressure for working and traction hydraulics	200 bar
Operating pressure Slewing gear	150 bar
RPM / speed Superstructure	10 rpm
Hydraulic oil tank Contents	19 l

Undercarriage

Travel speed max.	4.1 km/h
Chain width	250 mm
Ground clearance	170 mm

Dozer Blade

Width	990 mm
Height	220 mm
Stroke Standard dozer blade above ground	220 mm
Stroke Standard dozer blade below ground	300 mm

Sound level

Sound level (LwA) acc. to 2000/14/EC	93 dB(A)
Cabin - specified sound pressure level LpA acc. to ISO 6394	75.8 dB(A)

ET20 Dimensions

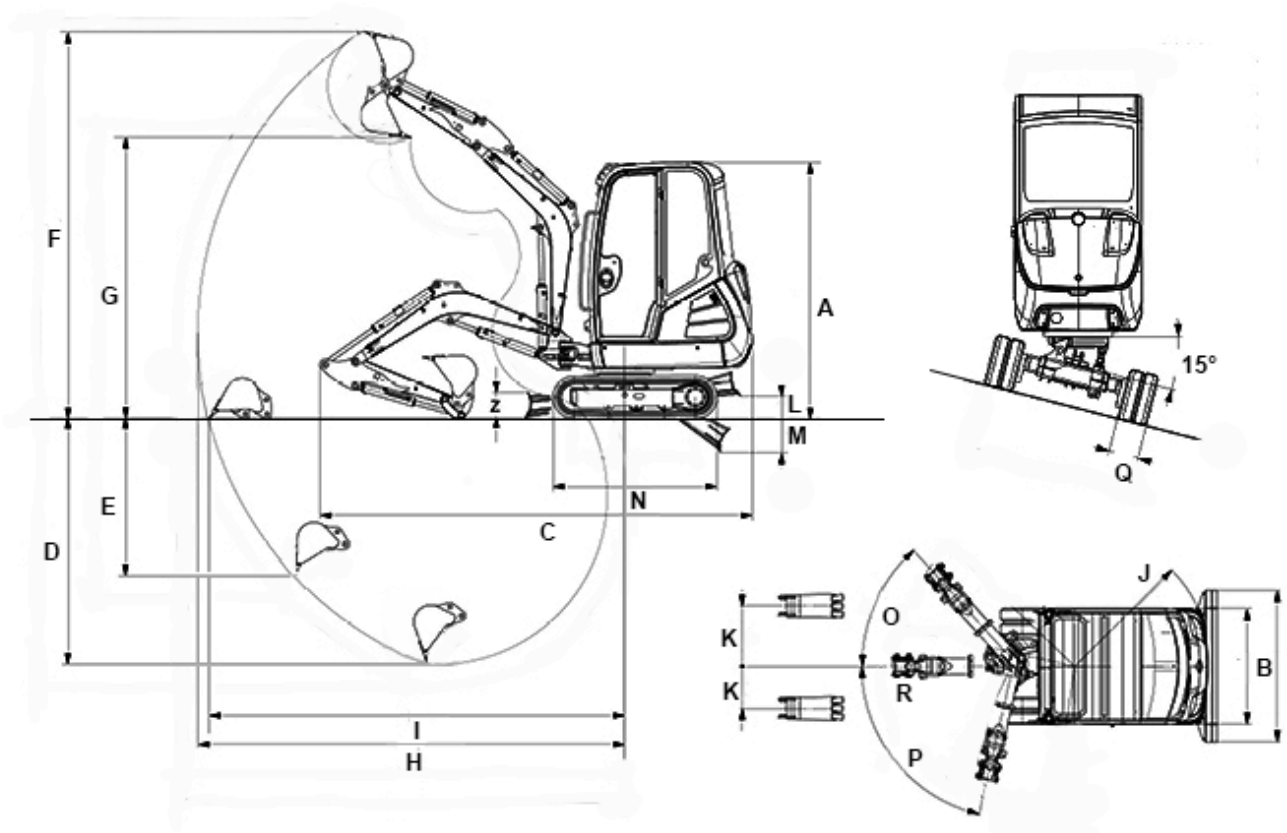

VDS

A	Height	2,295 mm	2,388 mm
B	Width Superstructure	990 mm	990 mm
B	Width undercarriage retracted	990 mm	990 mm
B	Width undercarriage extended (telescopic undercarriage only)	1,300 mm	1,300 mm
B	Width Dozer blade	990 mm	990 mm
B	Width Dozer blade width with extension (telescopic undercarriage only)	1,300 mm	1,300 mm
C	Transport length	4,049 mm	4,024 mm
D	Digging depth max. Max. (short dipper stick)	2,483 mm	2,391 mm
D	Digging depth max. Max. (long dipper stick)	2,683 mm	2,590 mm
E	Insertion depth Max. , vertikal (short dipper stick)	1,660 mm	1,567 mm
E	Insertion depth Max., vertikal (long dipper stick)	1,845 mm	1,752 mm
F	Insertion height Max. (short dipper stick)	3,836 mm	3,929 mm
F	Insertion height Max. (long dipper stick)	3,959 mm	4,052 mm
G	Dump height max. Max. (short dipper stick)	2,713 mm	2,805 mm
G	Dump height max. Max. (long dipper stick)	2,836 mm	2,928 mm
H	Digging radius max. Max. (short dipper stick)	4,129 mm	4,129 mm
H	Digging radius max. Max. (long dipper stick)	4,317 mm	4,317 mm

I	Range Max.,on the ground (short dipper stick)	4,031 mm	4,005 mm
I	Range Max. ,on the ground (long dipper stick)	4,225 mm	4,201 mm
J	Rear swivel radius Min.	1,169 mm	1,169 mm
K	Arm displacement Max. , to centre of bucket, right side	516 mm	516 mm
K	Arm displacement Max. , to centre of bucket, left side	359 mm	359 mm
L	Lift height Max., of dozer blade above ground (short)	216 mm	264 mm
L	Lift height Max., of dozer blade above ground (long)	299 mm	353 mm
M	Scraping depth Max., of dozer blade below ground (short)	297 mm	255 mm
M	Scraping depth Max., of dozer blade below ground (long)	362 mm	312 mm
N	Length Total crawler length (standard undercarriage)	1,708 mm	1,709 mm
--	Length Crawler length Sprocket wheel (standard undercarriage)	1,325 mm	1,326 mm
O	Turning angle Max. of boom system to the right	48 °	48 °
P	Turning angle Max. of boom system to the left	77 °	77 °
R	Boom slewing radius centre	1,666 mm	1,666 mm
--	Boom slewing radius right	1,582 mm	1,582 mm
--	Boom slewing radius left max.	1,356 mm	1,356 mm
--	Boom slewing radius left lock	1,449 mm	1,450 mm
Z	Height Dozer blade	230 mm	230 mm

Please note: that product availability can vary from country to country. It is possible that information / products may not be available in your country. More detailed information on engine power can be found in the operator's manual; the stated power may vary due to specific operating conditions. Subject to alterations and errors excepted. Applicable also to illustrations.
Copyright © 2019 Wacker Neuson SE.