

1601

Wheel Dumpers



**WACKER
NEUSON**
all it takes!



Three different types of skip mean even greater utility

Even greater utility for building processes, logistics and environmental technology: The standard front-tipping skip is ideal for fast material turnover. The high-tipping skip bridges differences in height. The swivel-tipping skip with its 180-degree tilt dumps the material precisely where it is needed.

- Three different types of skip: Front-tipping skip (standard); high-tipping skip and optional swivel tipping skip, maximum payload 1,500 kg.
- Hydrostatic twin-lock all-wheel drive.
- Continuously variable speed up to 16 km/h max.
- Large service and maintenance access.
- Clearly laid out instrument panel and wide, robust leg protection.

1601 Technical specifications

| | Front tip skip | Swivel tip skip | High tip skip |
|--|--------------------|--------------------|--------------------|
| Operating data | | | |
| Payload kg | 1,500 | 1,500 | 1,500 |
| Shipping weight kg | 1,261 | 1,261 | 1,261 |
| Skip capacity level I | 829 | 650 | 650 |
| Skip capacity heaped I | 1,044 | 800 | 800 |
| Skip capacity water level I | 612 | 325 | 420 |
| Engine / Motor | | | |
| Engine / Motor manufacturer | Yanmar | Yanmar | Yanmar |
| Engine / Motor type | 3TNV76 | 3TNV76 | 3TNV76 |
| Engine / Motor | Diesel | Diesel | Diesel |
| Engine performance acc. to ISO 3046/1 kW | 18.9 | 18.9 | 18.9 |
| Displacement cm ³ | 1,116 | 1,116 | 1,116 |
| Engine RPM rpm | 3000 | 3000 | 3000 |
| Travel speed km/h | 16 | 16 | 16 |
| Articulation angle ° | 33 | 33 | 33 |
| Pendulum angle ° | 15 | 15 | 15 |
| Turning radius mm | 3,300 | 3,300 | 3,300 |
| Gradeability % | 50 | 50 | 50 |
| Tires | 10.00/75-15 | 10.00/75-15 | 10.00/75-15 |
| L x W x H mm | 3310 x 1310 x 2550 | 3220 x 1310 x 2550 | 3300 x 1310 x 2550 |
| Steering pump | Axial piston pump | Axial piston pump | Axial piston pump |
| Flow rate l/min | 84 | 84 | 84 |
| Operating pressure bar | 420 | 420 | 420 |
| Duty pump | Gear pump | Gear pump | Gear pump |
| Flow rate l/min | 18 | 18 | 18 |
| Operating pressure bar | 170 | 170 | 170 |
| Fuel tank capacity l | 20 | 20 | 20 |
| Sound level (LwA) dB(A) | 101 | 101 | 101 |

1601 Dimensions

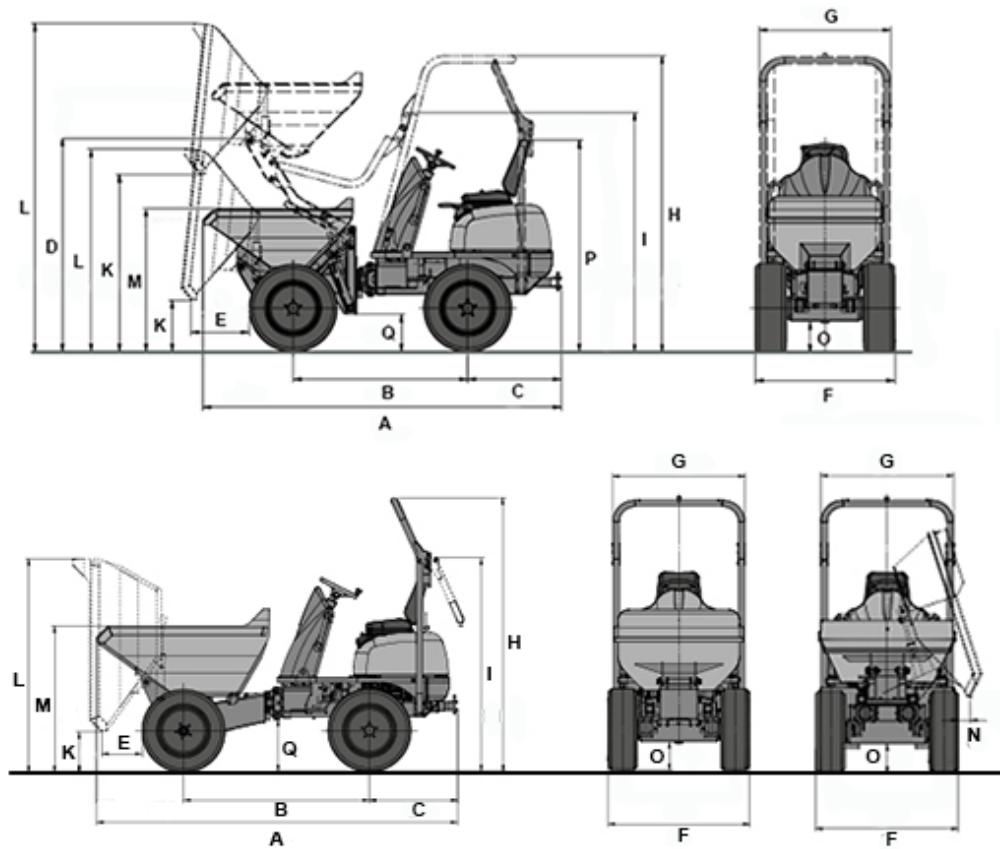

| | | Front tip skip | Swivel tip skip | High tip skip |
|---|---------------------------------------|----------------|-----------------|---------------|
| A | Overall length | 3,310 mm | 3,220 mm | 3,300 mm |
| B | Wheelbase | 1,700 mm | 1,700 mm | 1,650 mm |
| C | Rear overhang | 810 mm | 810 mm | 810 mm |
| D | Height | | | 1,885 mm |
| E | Dumping distance | 370 mm | 280 mm | 400 mm |
| F | Width vehicle | 1,305 mm | 1,305 mm | 1,305 mm |
| G | Skip width | 1,300 mm | 1,260 mm | 1,200 mm |
| H | Height ROPS | 2,550 mm | 2,550 mm | 2,550 mm |
| I | Height ROPS tipped | 1,960 mm | 2,000 mm | 2,000 mm |
| K | Dump height max. | 360 mm | 705 mm | 370 mm |
| K | Dump height max. High tip skip raised | | | 1,600 mm |
| L | Skip height gekippt | 1,970 mm | 2,240 mm | 1,895 mm |
| L | Skip height High tip skip raised | | | 2,975 mm |
| M | Skip height | 1,345 mm | 1,310 mm | 1,345 mm |
| N | Dumping distance lateral | | 100 mm | |
| O | Ground clearance | 260 mm | 270 mm | 270 mm |
| Q | Distance | 460 mm | | 390 mm |

Please note: that product availability can vary from country to country. It is possible that information / products may not be available in your country. More detailed information on engine power can be found in the operator's manual; the stated power may vary due to specific operating conditions. Subject to alterations and errors excepted. Applicable also to illustrations.
Copyright © 2019 Wacker Neuson SE.