

New

Adapter Plate

for KOSMEK Robotic Hand Changer (model SWR)

Connect Robot and Robotic Hand Changer !

Saves Design Time and Costs !

Based on ISO Mounting Pattern

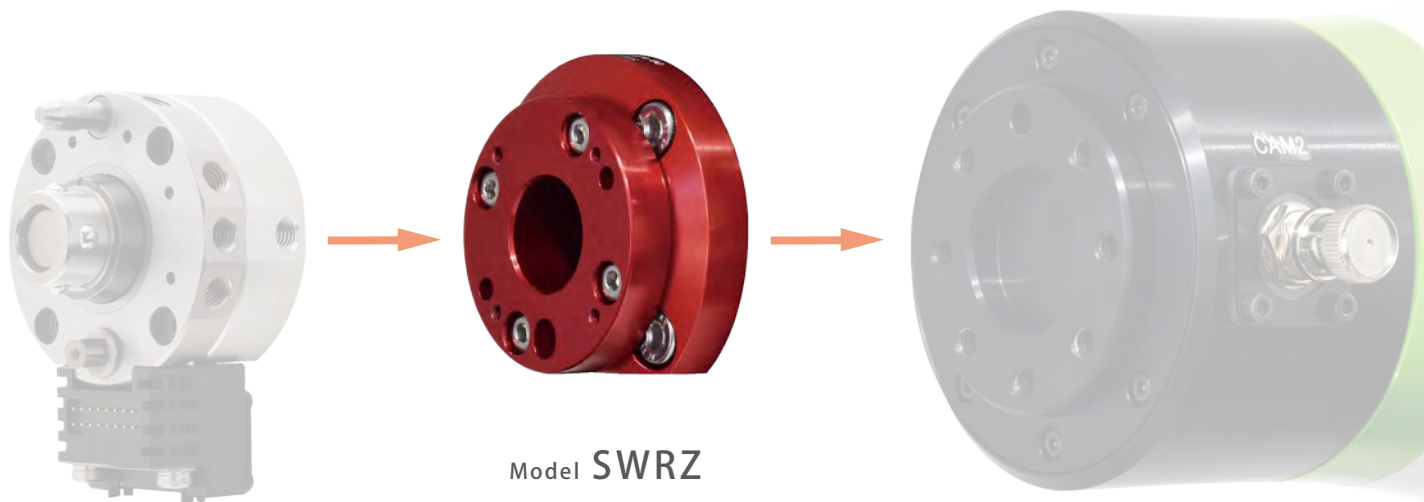

Model SWRZ

Robot Application

Adapter Plate

for SWR Robotic Hand Changer

Model **SWRZ**



Connect Robot and Robotic Hand Changer ! Designing Not Required !
Applicable to ISO Mounting Pattern

Simple & Convenient !

Not required to design or make an adapter plate!

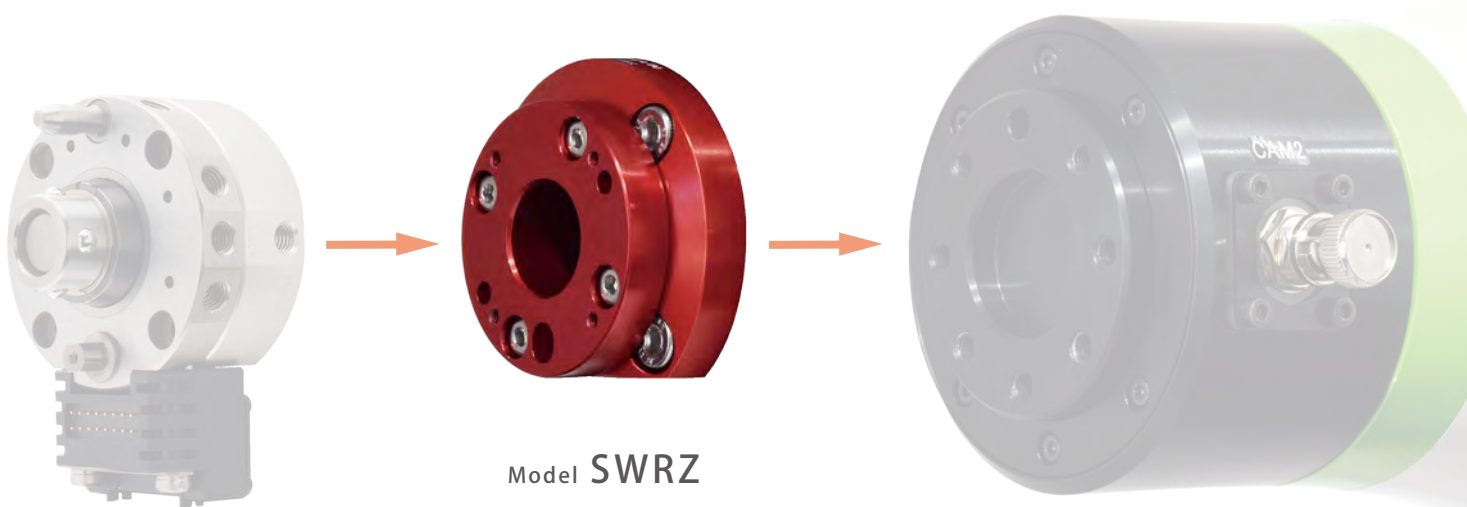

Model **SWRZ**

Applicable to ISO Mounting Pattern

Model No. Indication

SWRZ 007 0 - MF 2

1 2 3

1 Robotic Hand Changer (SWR) Applicable Model

003 : SWR0030
007 : SWR0070
012 : SWR0120
025 : SWR0250
Y01 : SWRY0010

3 Applicable Mounting Pattern Number

2 : ISO Mounting Pattern Number 2
3 : ISO Mounting Pattern Number 3
4 : ISO Mounting Pattern Number 4
5 : ISO Mounting Pattern Number 5

※ Please contact us for other ISO mounting pattern numbers.

2 Design No.

0 : Revision Number

Specifications

Adapter Plate Model No.	Weight ^{※1} (g)	Applicable ISO Mounting Pattern Number	Applicable Robotic Hand Changer (SWR) Model No.	Applicable SWR : 4 External Option Symbol (● = Attachable) ^{※2}			Applicable SWR : 5 Joint Option
				D : D-sub Connector	J : Resin Connector	W : Compact Waterproof Electrode	
SWRZ0030-MF2	23	2	SWR0030	-	●	●	Blank ^{※3}
SWRZ0070-MF2	39	2	SWR0070	-	●	●	Blank ^{※3}
SWRZ0070-MF3	59	3	SWR0070	-	●	●	Blank ^{※3}
SWRZ0070-MF4	100	4	SWR0070	-	●	●	Blank / S
SWRZ0120-MF3	62	3	SWR0120	-	●	●	Blank ^{※3}
SWRZ0120-MF4	105	4	SWR0120	-	●	●	Blank / S
SWRZ0120-MF5	135	5	SWR0120	-	●	●	Blank ^{※3}
SWRZ0250-MF3	126	3	SWR0250	●	●	●	Blank / S
SWRZ0250-MF5	128	5	SWR0250	●	●	●	Blank / S
SWRZY010-MF2	55	2	SWRY0010	-	●	●	Blank ^{※3}

Notes :

- ※1. It shows the weight of an adapter plate only. Bolts and pins are not included.
- ※2. Please note that depending on a construction condition, cables and pipes of an option that are projected from the end surface of the option to the robot flange side may affect robot cables and pipes when operating a robot.
- ※3. Joint Option S : with Check Valve cannot be installed.

(Reference) SWR Master Cylinder Model No. Indication

SWR 003 0 - M - J

Payload Design No.

4

SWR 007 012 025 0 - M F A - J - Blank S

Payload Design No.

Port Option

4

5

SWRY001 0 - M - J

Design No.

4

4 External Option Symbols

Blank : No Option
D : D-sub Connector
J : Resin Connector
W : Compact Waterproof Electrode

5 Joint Option

Blank : No Check Valve (Standard)
S : with Check Valve

External Dimensions : SWRZ0030-MF2

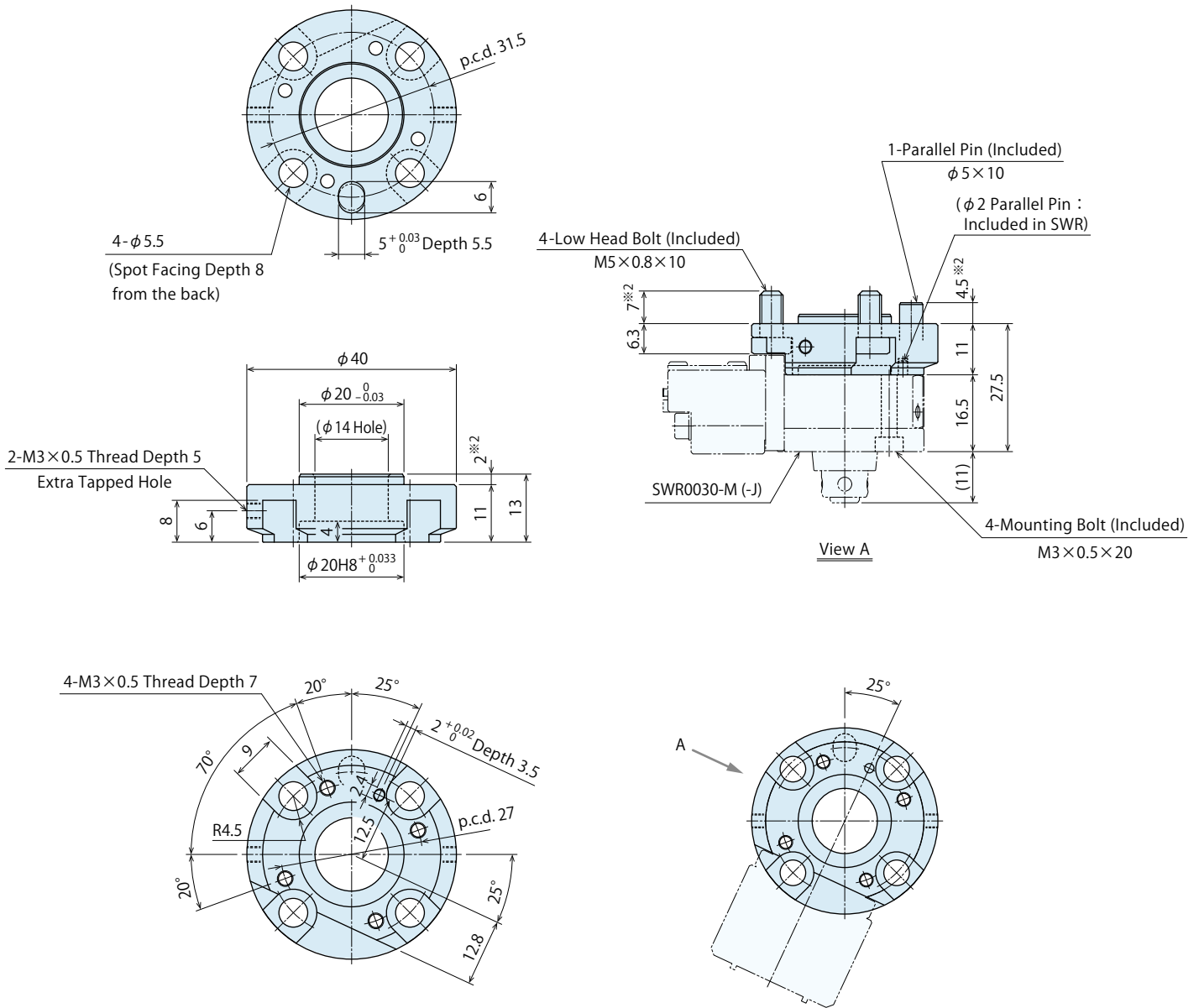

Adapter Plate Model No.	SWRZ0030-MF2
Weight	23g ^{※1}
Applicable Mounting Pattern No.	2
Applicable Robotic Hand Changer Model No.	SWR0030-M
Attachable External Electrode Option	Blank : No Option J : Resin Connector W : Compact Waterproof Electrode
SWR Joint Option	Blank : No Check Valve

1. Material : A2017BE-T4 Surface Finishing : Anodized Aluminum Finishing (Red)
 ※1. It shows the weight of an adapter plate only. Bolts and pins are not included.
 ※2. The hole depth of the robot side differs depending on a robot. Make sure to check the robot flange dimensions before use.

External Dimensions : SWRZ0070-MF2

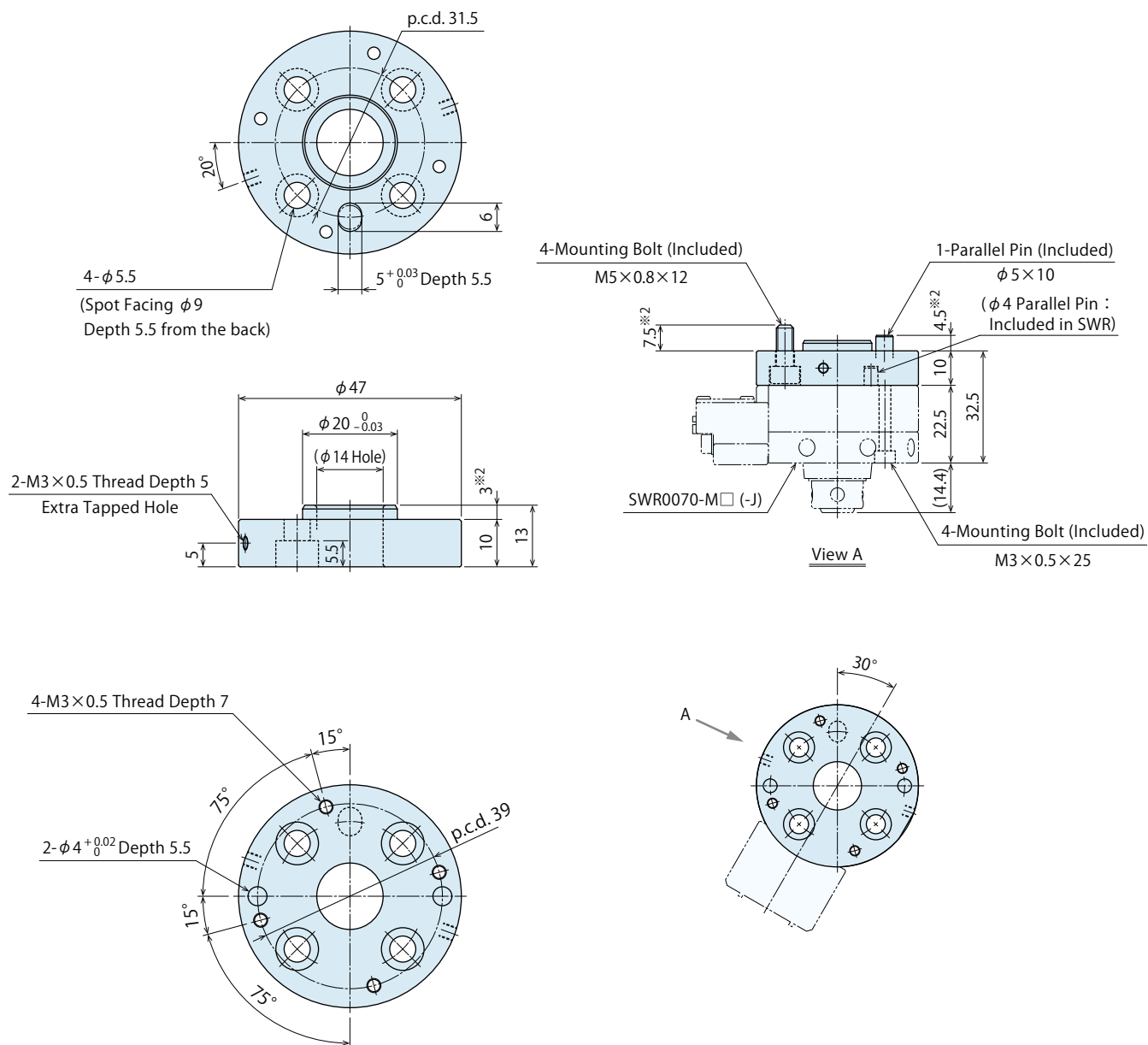

Adapter Plate Model No.	SWRZ0070-MF2
Weight	39g ^{※1}
Applicable Mounting Pattern No.	2
Applicable Robotic Hand Changer Model No.	SWR0070-MF SWR0070-MA
Attachable External Electrode Option	Blank : No Option J : Resin Connector W : Compact Waterproof Electrode
SWR Joint Option	Blank : No Check Valve

1. Material : A2017BE-T4 Surface Finishing : Anodized Aluminum Finishing (Red)

※1. It shows the weight of an adapter plate only. Bolts and pins are not included.

※2. The hole depth of the robot side differs depending on a robot. Make sure to check the robot flange dimensions before use.

External Dimensions : SWRZ0070-MF3

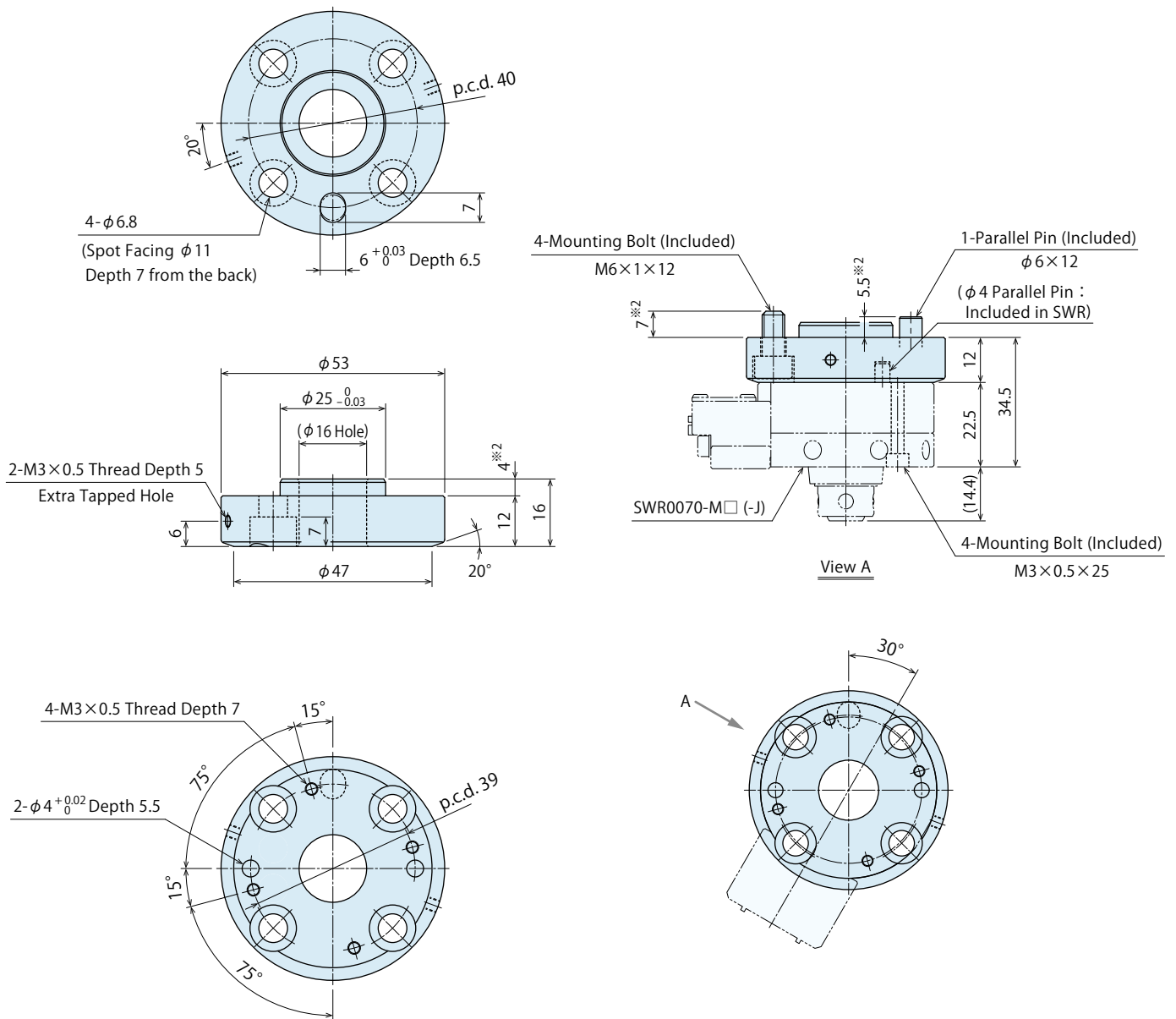

Adapter Plate Model No.	SWRZ0070-MF3
Weight	59g ^{※1}
Applicable Mounting Pattern No.	3
Applicable Robotic Hand Changer Model No.	SWR0070-MF SWR0070-MA
Attachable External Electrode Option	Blank : No Option J : Resin Connector W : Compact Waterproof Electrode
SWR Joint Option	Blank : No Check Valve

1. Material : A2017BE-T4 Surface Finishing : Anodized Aluminum Finishing (Red)
 ※1. It shows the weight of an adapter plate only. Bolts and pins are not included.
 ※2. The hole depth of the robot side differs depending on a robot. Make sure to check the robot flange dimensions before use.

External Dimensions : SWRZ0070-MF4

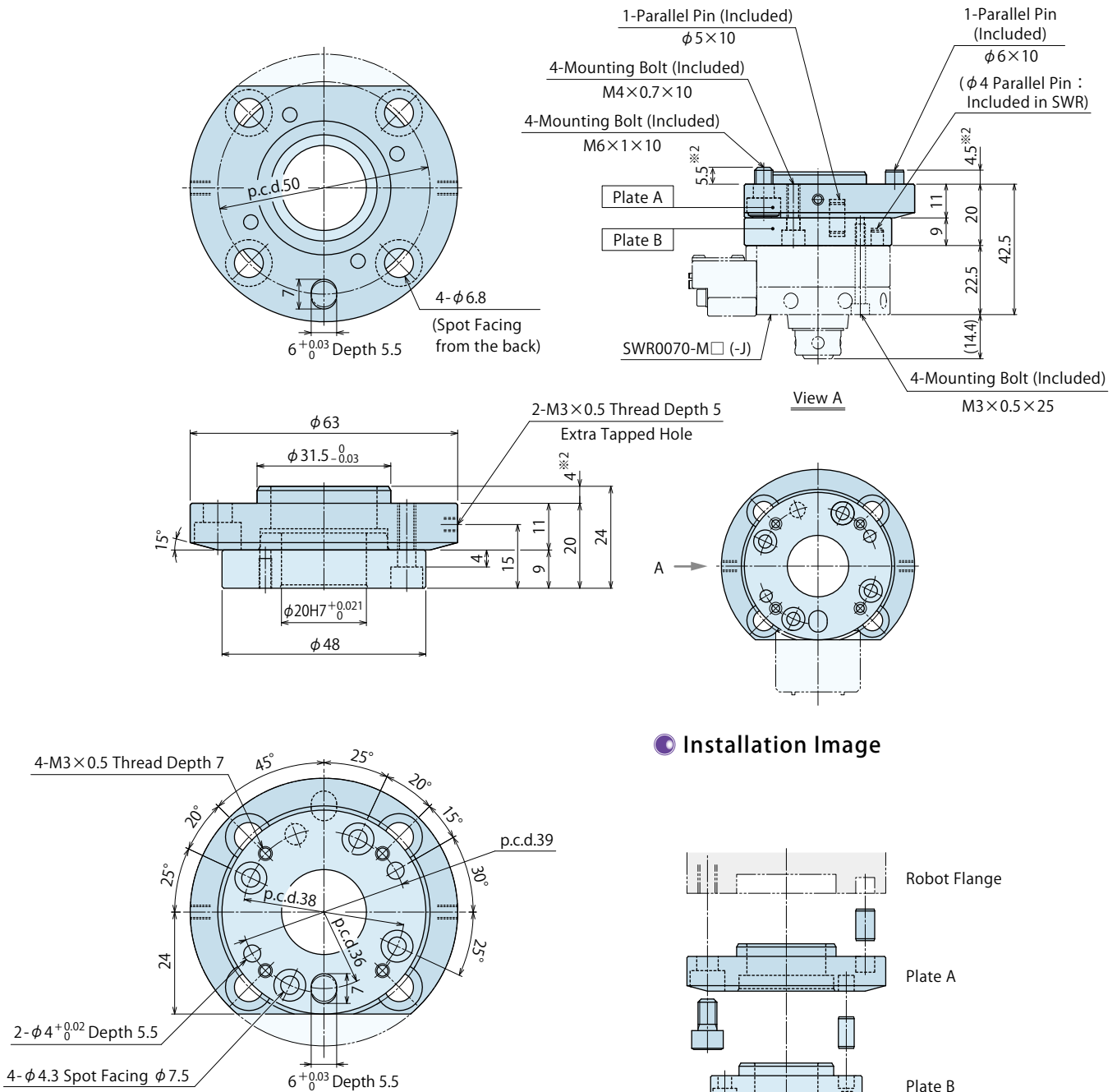

Installation Image

Adapter Plate Model No.	SWRZ0070-MF4
Weight	100g ^{※1}
Applicable Mounting Pattern No.	4
Applicable Robotic Hand Changer Model No.	SWR0070-MF SWR0070-MA
Attachable External Electrode Option	Blank : No Option J : Resin Connector W : Compact Waterproof Electrode
SWR Joint Option	Blank : No Check Valve S : with Check Valve

1. Material : A2017BE-T4 Surface Finishing : Anodized Aluminum Finishing (Red)

※1. It shows the weight of an adapter plate only. Bolts and pins are not included.

※2. The hole depth of the robot side differs depending on a robot. Make sure to check the robot flange dimensions before use.

External Dimensions : SWRZ0120-MF3

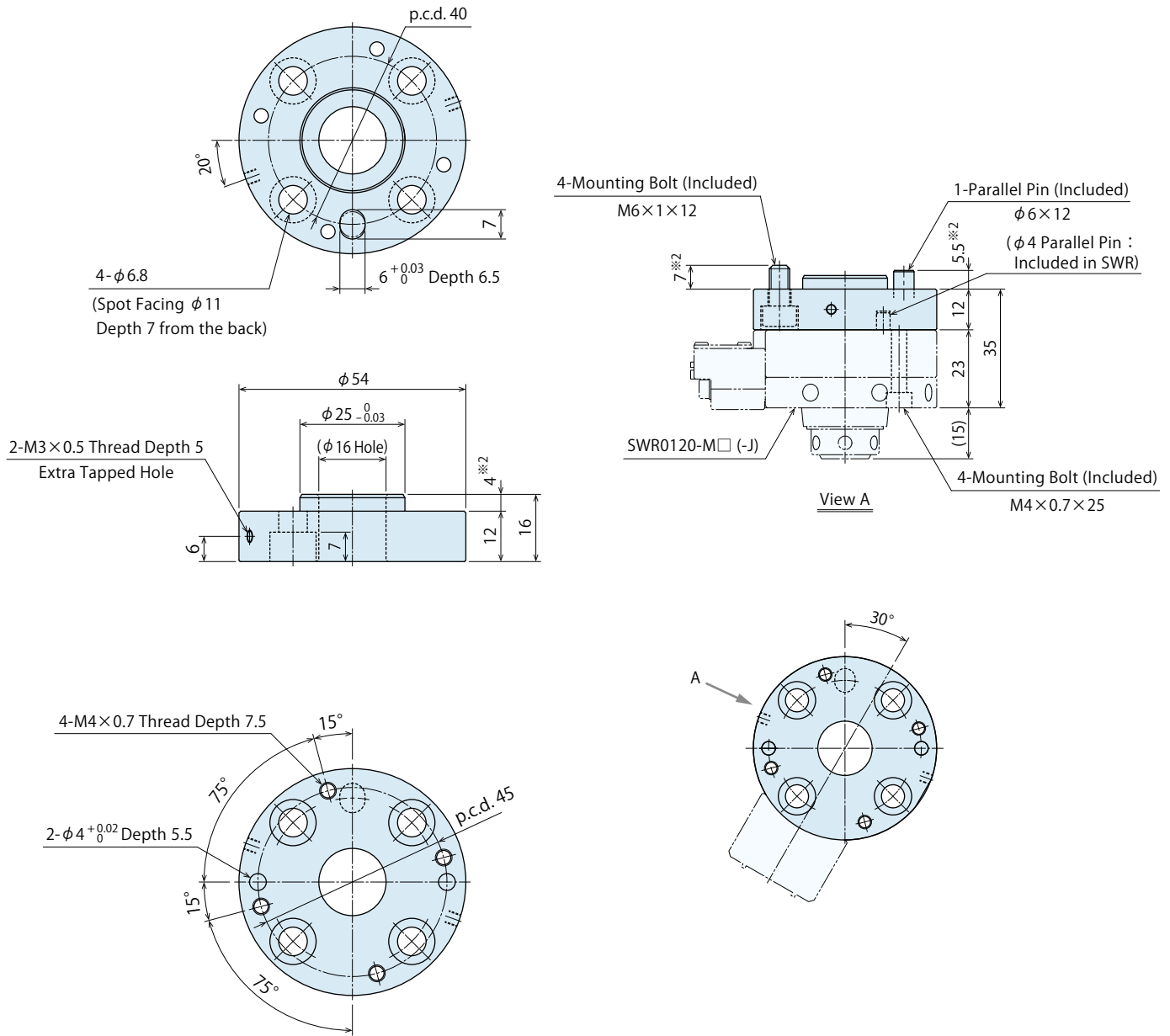

Adapter Plate Model No.	SWRZ0120-MF3
Weight	62g ^{※1}
Applicable Mounting Pattern No.	3
Applicable Robotic Hand Changer Model No.	SWR0120-MF SWR0120-MA
Attachable External Electrode Option	Blank : No Option J : Resin Connector W : Compact Waterproof Electrode
SWR Joint Option	Blank : No Check Valve

1. Material : A2017BE-T4 Surface Finishing : Anodized Aluminum Finishing (Red)
 ※1. It shows the weight of an adapter plate only. Bolts and pins are not included.
 ※2. The hole depth of the robot side differs depending on a robot. Make sure to check the robot flange dimensions before use.

External Dimensions : SWRZ0120-MF4

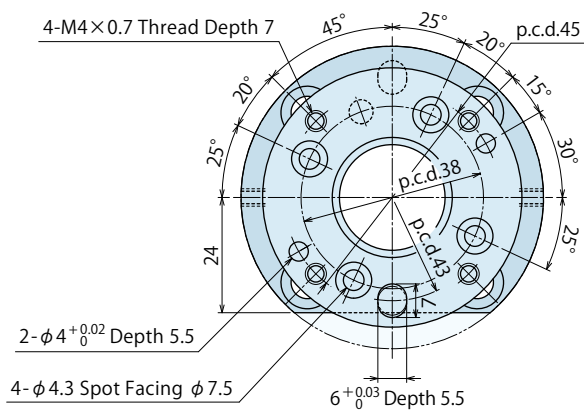
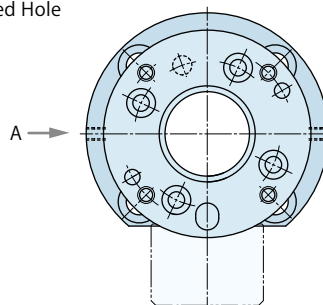
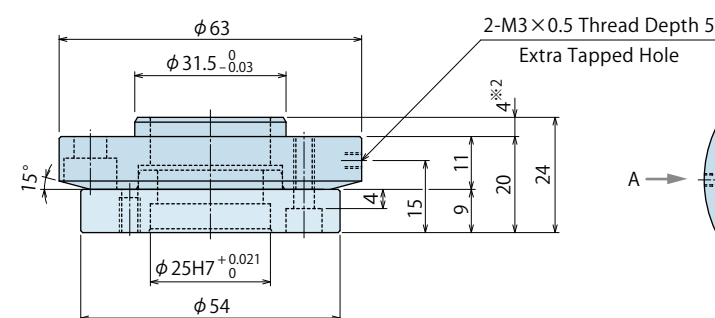
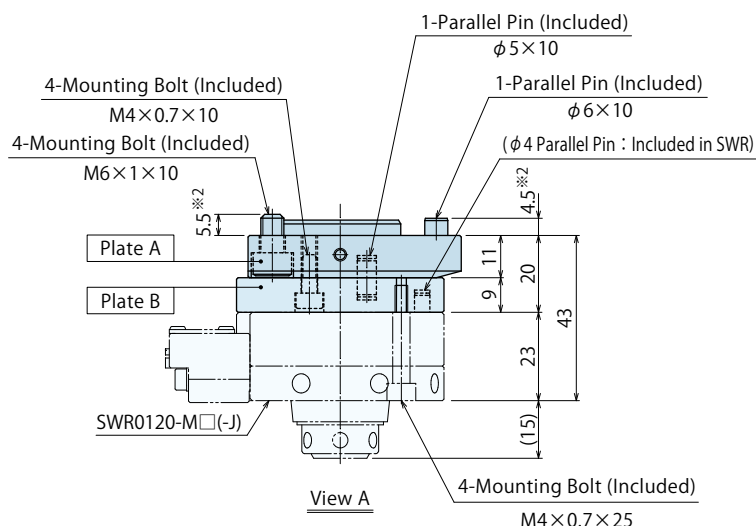
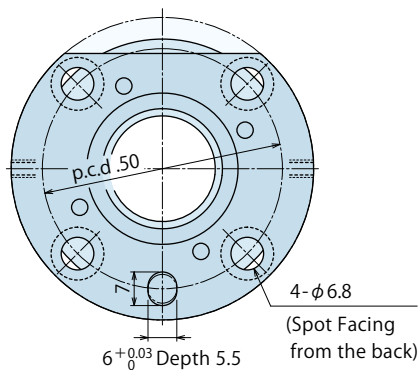

Installation Image

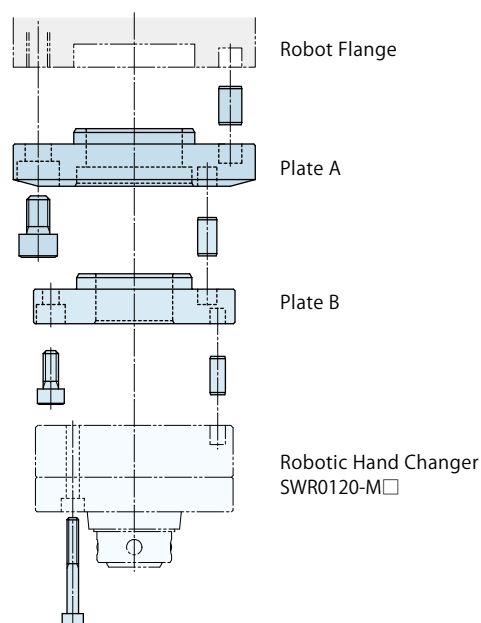

Adapter Plate Model No.	SWRZ0120-MF4
Weight	105g ^{※1}
Applicable Mounting Pattern No.	4
Applicable Robotic Hand Changer Model No.	SWR0120-MF SWR0120-MA
Attachable External Electrode Option	Blank : No Option J : Resin Connector W : Compact Waterproof Electrode
SWR Joint Option	Blank : No Check Valve S : with Check Valve

1. Material : A2017BE-T4 Surface Finishing : Anodized Aluminum Finishing (Red)

※1. It shows the weight of an adapter plate only. Bolts and pins are not included.

※2. The hole depth of the robot side differs depending on a robot. Make sure to check the robot flange dimensions before use.

External Dimensions : SWRZ0120-MF5

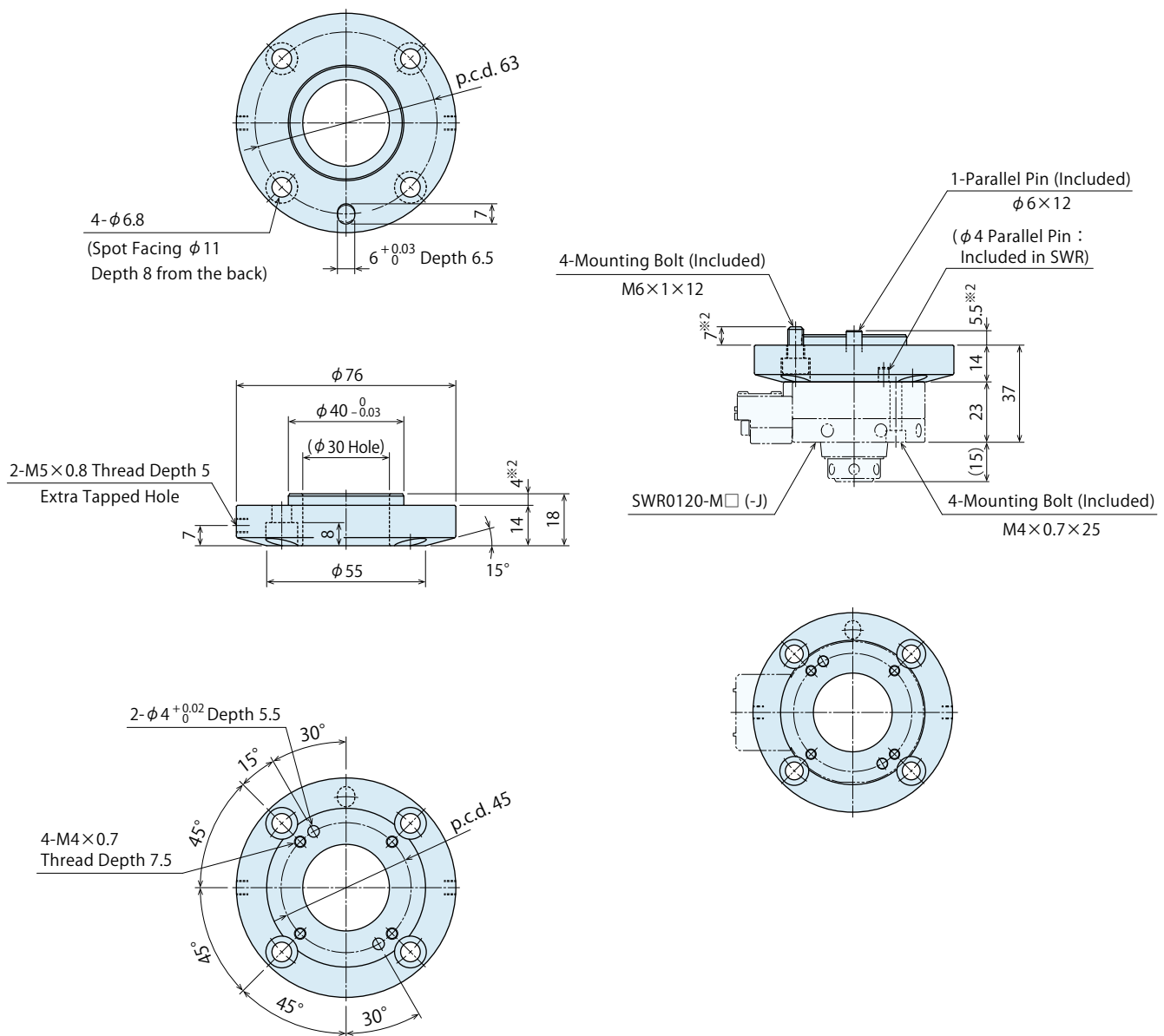

Adapter Plate Model No.	SWRZ0120-MF5
Weight	135g ^{※1}
Applicable Mounting Pattern No.	5
Applicable Robotic Hand Changer Model No.	SWR0120-MF SWR0120-MA
Attachable External Electrode Option	Blank : No Option J : Resin Connector W : Compact Waterproof Electrode
SWR Joint Option	Blank : No Check Valve

1. Material : A2017BE-T4 Surface Finishing : Anodized Aluminum Finishing (Red)

※1. It shows the weight of an adapter plate only. Bolts and pins are not included.

※2. The hole depth of the robot side differs depending on a robot. Make sure to check the robot flange dimensions before use.

External Dimensions : SWRZ0250-MF3

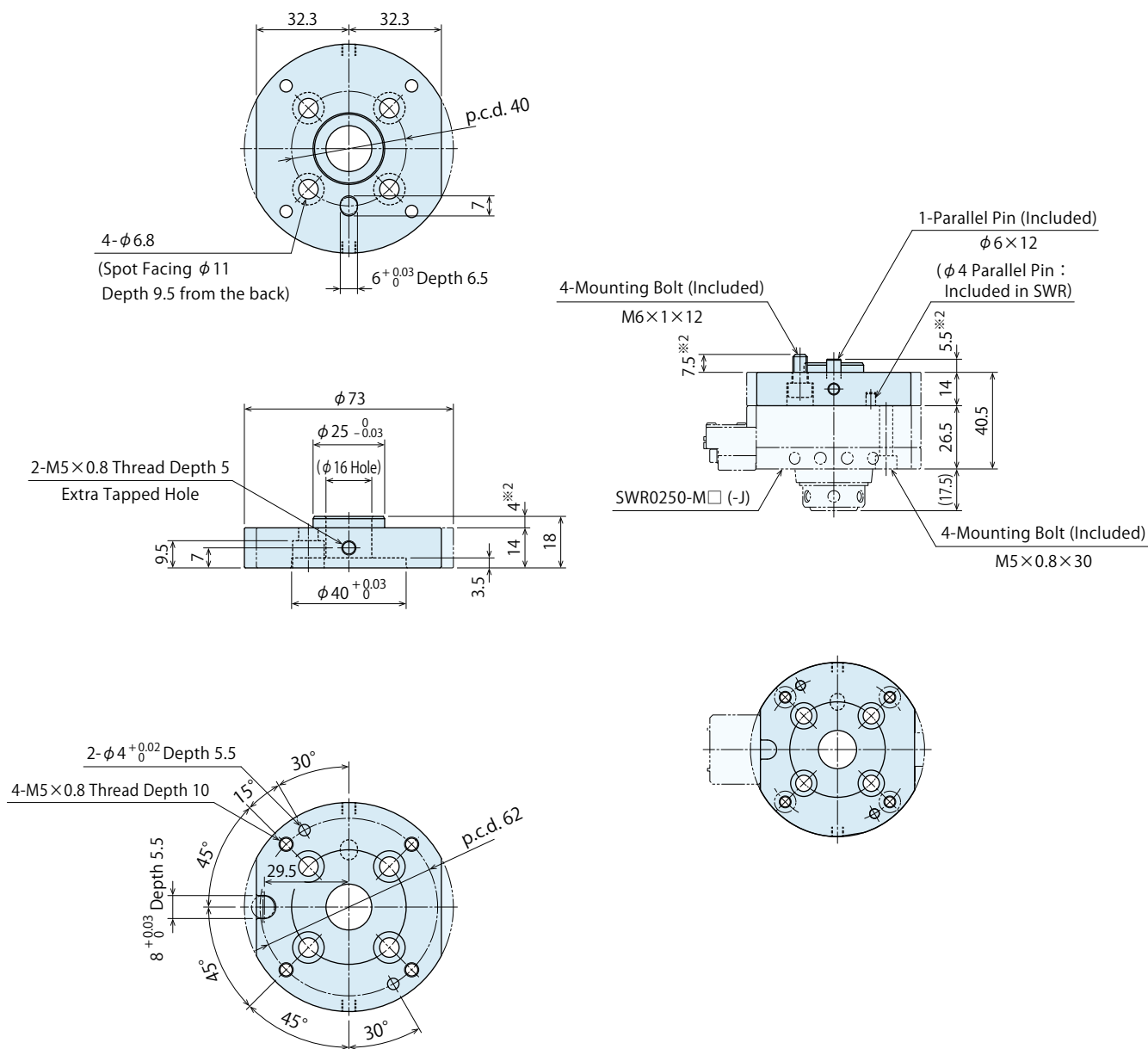

Adapter Plate Model No.	SWRZ0250-MF3
Weight	126g ^{*1}
Applicable Mounting Pattern No.	3
Applicable Robotic Hand Changer Model No.	SWR0250-MF SWR0250-MA
Attachable External Electrode Option	Blank : No Option D : D-sub Connector J : Resin Connector W : Compact Waterproof Electrode
SWR Joint Option	Blank : No Check Valve S : with Check Valve

1. Material : A2017BE-T4 Surface Finishing : Anodized Aluminum Finishing (Red)

*1. It shows the weight of an adapter plate only. Bolts and pins are not included.

*2. The hole depth of the robot side differs depending on a robot. Make sure to check the robot flange dimensions before use.

External Dimensions : SWRZ0250-MF5

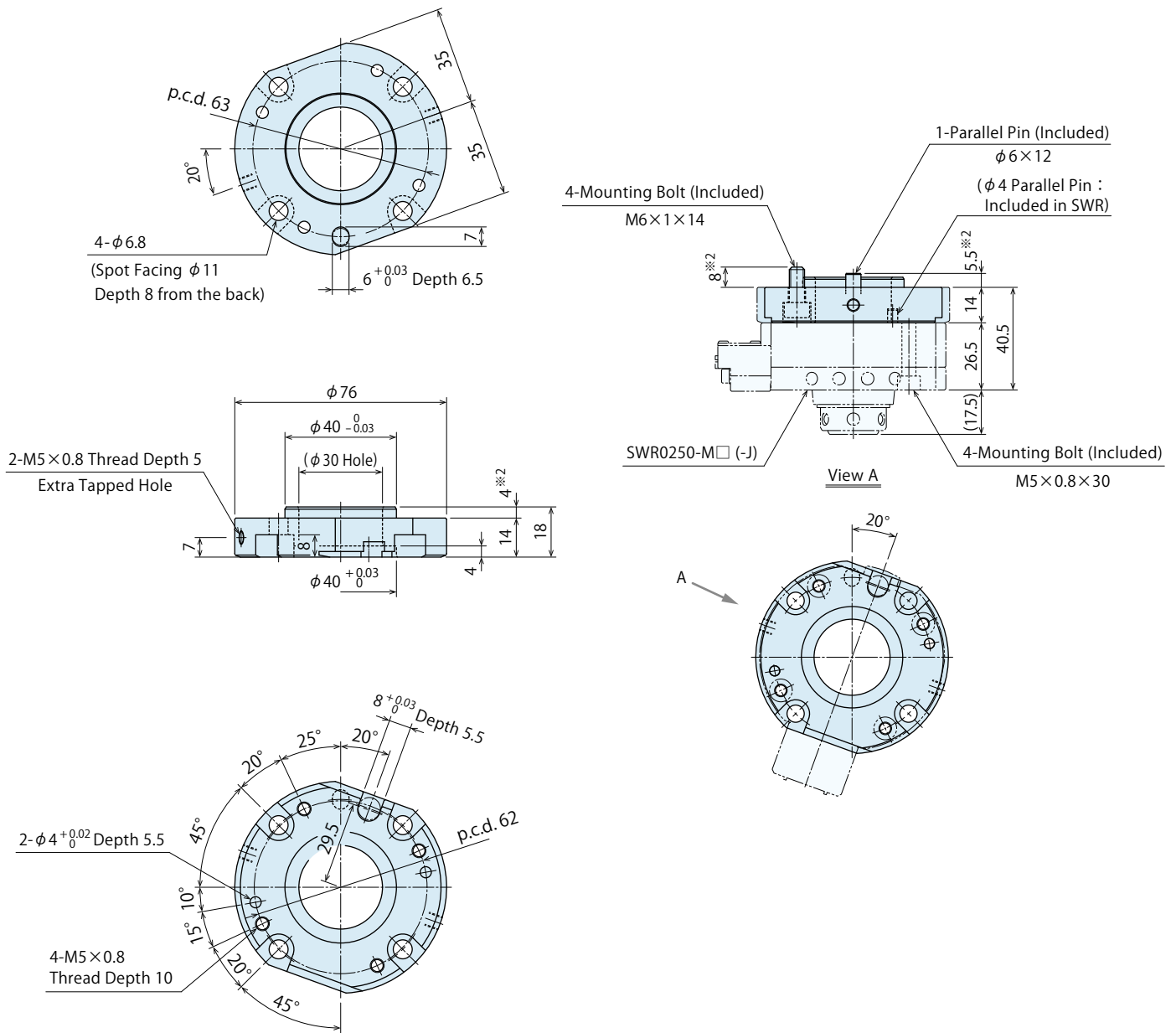

Adapter Plate Model No.	SWRZ0250-MF5
Weight	128g ^{※1}
Applicable Mounting Pattern No.	5
Applicable Robotic Hand Changer Model No.	SWR0250-MF SWR0250-MA
Attachable External Electrode Option	Blank : No Option D : D-sub Connector J : Resin Connector W : Compact Waterproof Electrode
SWR Joint Option	Blank : No Check Valve S : with Check Valve

1. Material : A2017BE-T4 Surface Finishing : Anodized Aluminum Finishing (Red)

※1. It shows the weight of an adapter plate only. Bolts and pins are not included.

※2. The hole depth of the robot side differs depending on a robot. Make sure to check the robot flange dimensions before use.

External Dimensions : SWRZY010-MF2

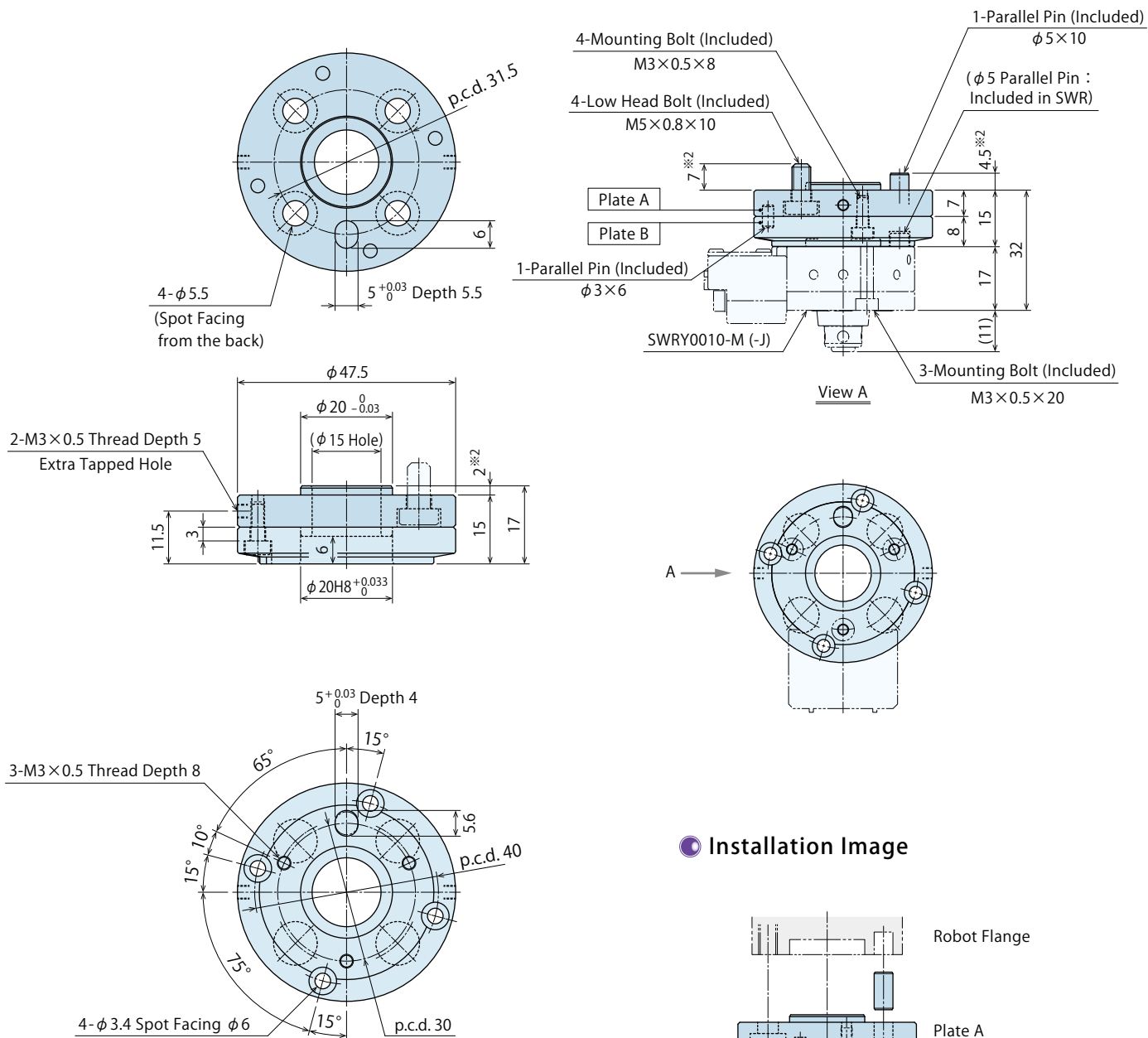

Installation Image

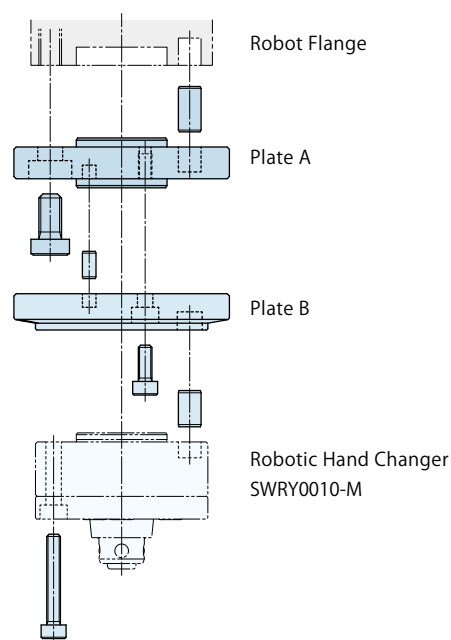

Adapter Plate Model No.	SWRZY010-MF2
Weight	55g ^{※1}
Applicable Mounting Pattern No.	2
Applicable Robotic Hand Changer Model No.	SWRY0010-M
Attachable External Electrode Option	Blank : No Option J : Resin Connector W : Compact Waterproof Electrode
SWR Joint Option	Blank : No Check Valve

1. Material : A2017BE-T4 Surface Finishing : Anodized Aluminum Finishing (Red)

※1. It shows the weight of an adapter plate only. Bolts and pins are not included.

※2. The hole depth of the robot side differs depending on a robot. Make sure to check the robot flange dimensions before use.

Reference : Standard Dimensions of ISO Mounting Pattern

Extracted from JIS B 8436 : 2005 (ISO9409-1 : 2004)

Number : 1 ~ 5

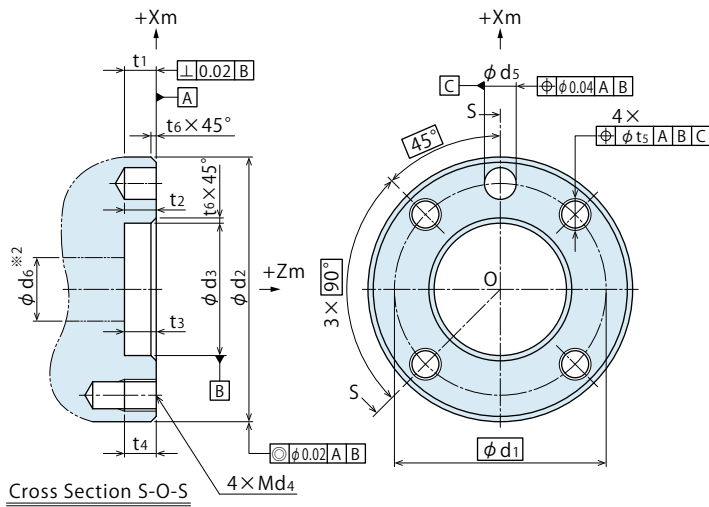

Number : 6 ~ 9, 11

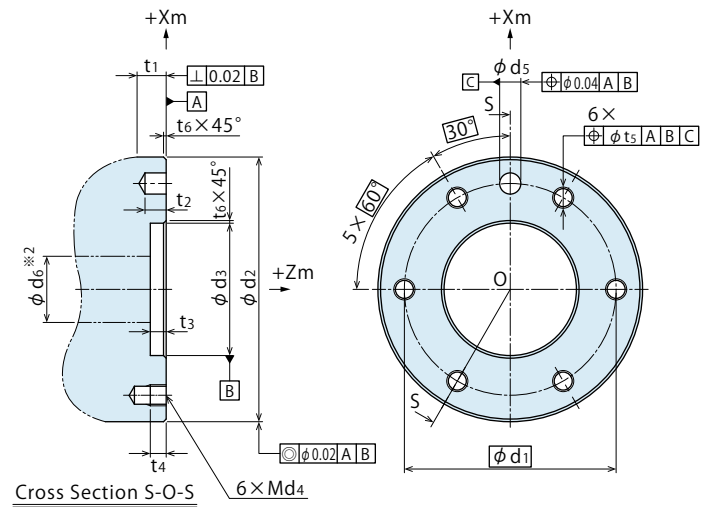

Number : 10

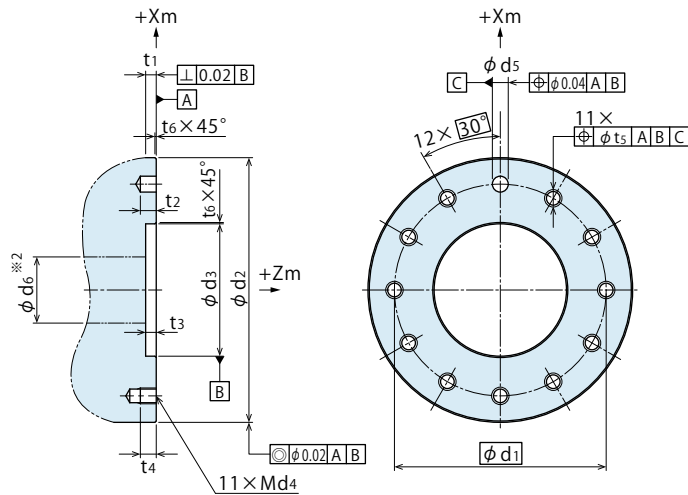

Number : 12

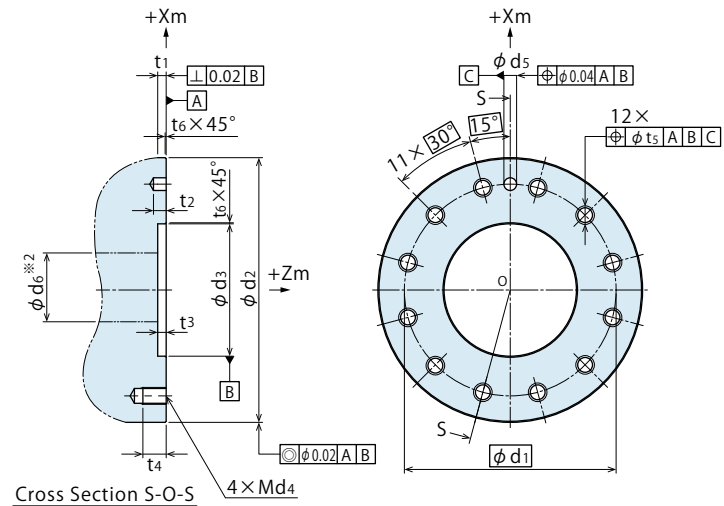

Dimensions of Flange Mounting Pattern

Unit : mm

Number	Pitch Circle Diam. ^{※1} d ₁	d ₂ h8	d ₃ H7	d ₄	d ₅ H7	t ₁ Min.	t ₂ Min.	t ₃ Min.	t ₄	t ₅	t ₆ Min.	Number of Tapped Holes N
	Series 1											
1	25	34	16	M4	4	6	4	4	※1	0.2	0.5	4
2	31.5	40	20	M5	5	6	5	4	※1	0.2	0.5	4
3	40	50	25	M6	6	6	6	6	※1	0.2	1	4
4	50	63	31.5	M6	6	6	6	6	※1	0.2	1	4
5	63	80	40	M6	6	6	6	6	※1	0.2	1	4
6	80	100	50	M8	8	6	8	6	※1	0.4	1	6
7	100	125	63	M8	8	6	8	6	※1	0.4	1	6
8	125	160	80	M10	10	8	10	8	※1	0.4	1	6
9	160	200	100	M10	10	8	10	8	※1	0.4	1	6
10	160	200	100	M12	12	8	12	8	※1	0.4	1	11
11	200	250	125	M12	12	8	12	8	※1	0.4	1	6
12	200	250	125	M16	12	8	12	8	22	0.4	1	11

Notes :

- ※1. Please determine the minimum depth of a tapped hole (t₄) considering the material of the end effector mounting part.
- ※2. Preparation for wiring and piping of dimension (d₆) : A through hole can be machined at the center of the flange. Diameter of the center hole (d₆) should be less than d₃.
- 1. Please refer to JIS B 8436 : 2005 (ISO 9409-1 : 2004) for further information.

● MEMO



KOSMEK LTD.

▶ <http://www.kosmek.com/>

HEAD OFFICE 1-5, 2-chome, Murotani, Nishi-ku, Kobe-city, Hyogo, Japan 651-2241
TEL.+81-78-991-5162 FAX.+81-78-991-8787

United States of America SUBSIDIARY	KOSMEK (USA) LTD. 650 Springer Drive, Lombard, IL 60148 USA TEL. +1-630-620-7650 FAX. +1-630-620-9015
MEXICO REPRESENTATIVE OFFICE	KOSMEK USA Mexico Office Av. Santa Fe 103, Int. 59, col. Santa Fe Juriquilla, Queretaro, QRO, 76230, Mexico TEL. +52-1-55-3044-9983
EUROPE SUBSIDIARY	KOSMEK EUROPE GmbH Schleppeplatz 2 9020 Klagenfurt am Wörthersee Austria TEL. +43-463-287587 FAX. +43-463-287587-20
CHINA SUBSIDIARY	KOSMEK (CHINA) LTD. Room601, RIVERSIDE PYRAMID No.55, Lane21, Pusan Rd, Pudong Shanghai 200125, China TEL. +86-21-54253000
INDIA BRANCH OFFICE	KOSMEK LTD. - INDIA 4A/Old No:649, Ground Floor, 4th D cross, MM Layout, Kavalbyrasandra, RT Nagar, Bangalore -560032 India TEL.+91-9880561695
THAILAND REPRESENTATIVE OFFICE	KOSMEK Thailand Representation Office 67 Soi 58, RAMA 9 Rd., Phatthanakan, Suanluang, Bangkok 10250, Thailand TEL. +66-2-300-5132 FAX. +66-2-300-5133

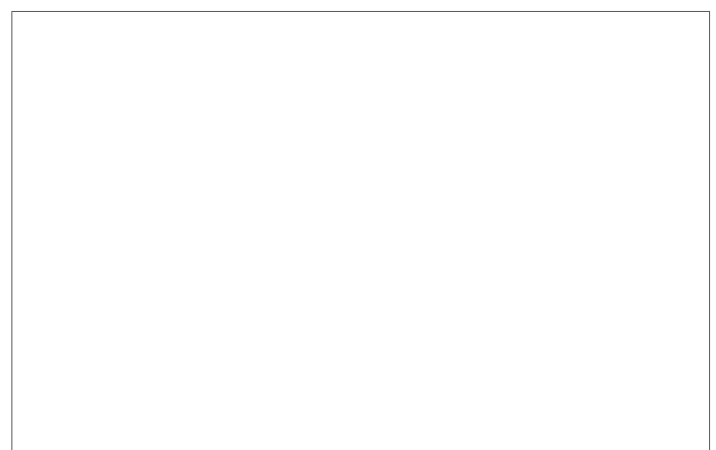

- For Further Information on Unlisted Specifications and Sizes, Please call us.
- Specifications in this Leaflet are Subject to Change without Notice.



JQA-QMA10823
KOSMEK HEAD OFFICE