

Model No. Indication

JES 000 0 - 02 L GN

1 2 3



1 Design No.

0 : Revision Number

2 Shape

Blank : Straight Shaped

L : L Shaped



3 Output Format • Detection Polarity

GN : NPN Output N-Pole Sensor (Cable Color: Black)

GS : NPN Output S-Pole Sensor (Cable Color: Gray)

GPN : PNP Output N-Pole Sensor (Cable Color: Black)

GPS : PNP Output S-Pole Sensor (Cable Color: Gray)

For detecting both lock and release actions, both the N-pole sensor and the S-pole sensor are required.

Application Table

Model No.	JES0000-02G□	JES0000-02LG□
	JES0000-02GP□	JES0000-02LGP□
WPT0500	●	●
WPT0600	●	●
WPT0800	●	●
WPT1000	●	●

Specifications

Model No.	JES0000-02G□	JES0000-02GP□
	JES0000-02LG□	JES0000-02LGP□
Wiring Method	3-Wire	
Applicable Load	Relay, Programmable Logic Controller (PLC)	
Voltage	DC 5 ~ 24V	
Output Specification	NPN (ON when in proximity)	PNP (ON when in proximity)
Output Current	15mA Max.	80mA Max.
Current Consumption	4mA Max.	12mA Max.
Response Speed	16 μsec or less	
Case Material	GF Reinforced PBT : Black	
Indicator Light	Red	
Withstand Voltage	AC1000V (1 minute / Packaged Charging Part / between the Case)	
Insulation Resistance	DC250V (20MΩ or more in Megohms, between the Case)	
Operating Temperature Range	-20°C ~ +85°C (Make sure no condensation)	
Operating Humidity Range	20 ~ 95%RH	
Protection Grade	IP67	
Cable Length	1m	

Performance Curve

JES detects only the magnetic force that is vertical to the detection surface. The operating curve is shown below. Operating point is on the steep part of the operating curve, so even small stroke can be surely detected.

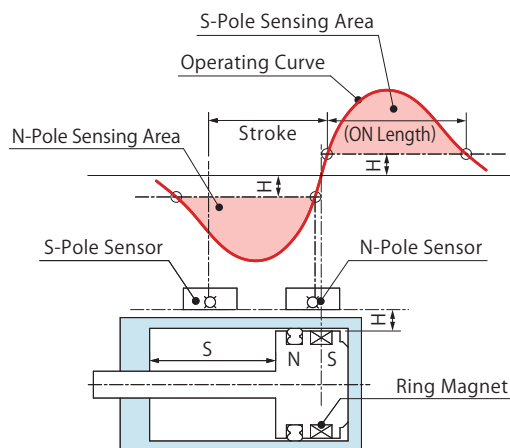

Electric Circuit Diagram

NPN Output

JES0000-02G□
JES0000-02LG□

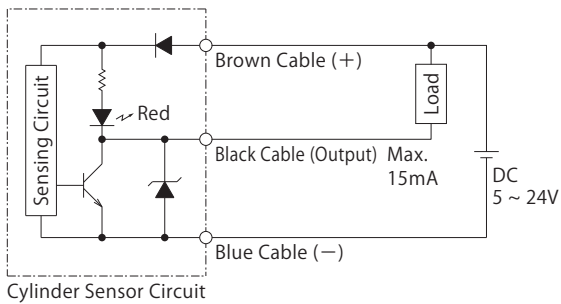

PNP Output

JES0000-02GP□
JES0000-02LGP□

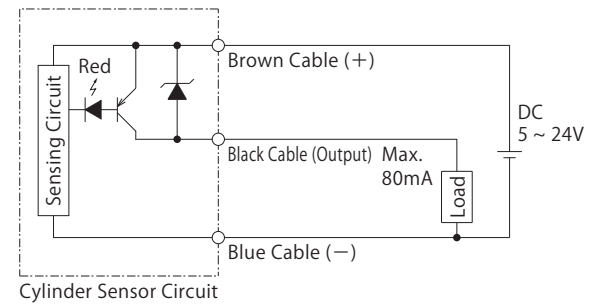

External Dimensions (Straight Shaped) : JES0000-02G□, JES0000-02GP□

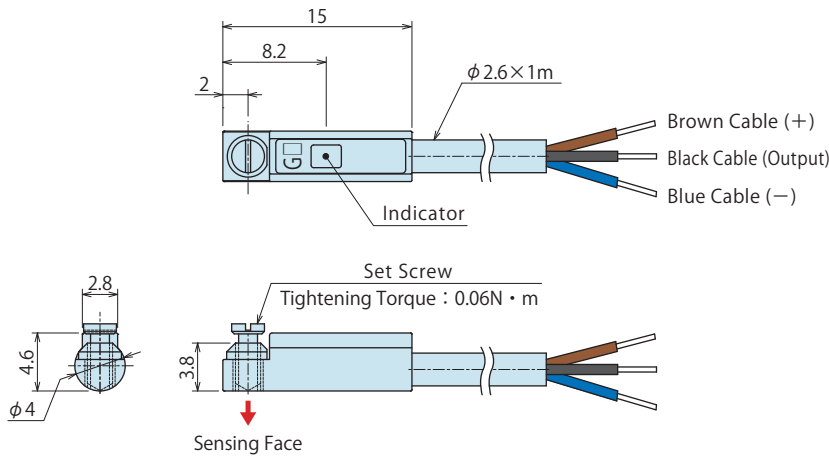

External Dimensions (L Shaped) : JES0000-02LG□, JES0000-02LGP□

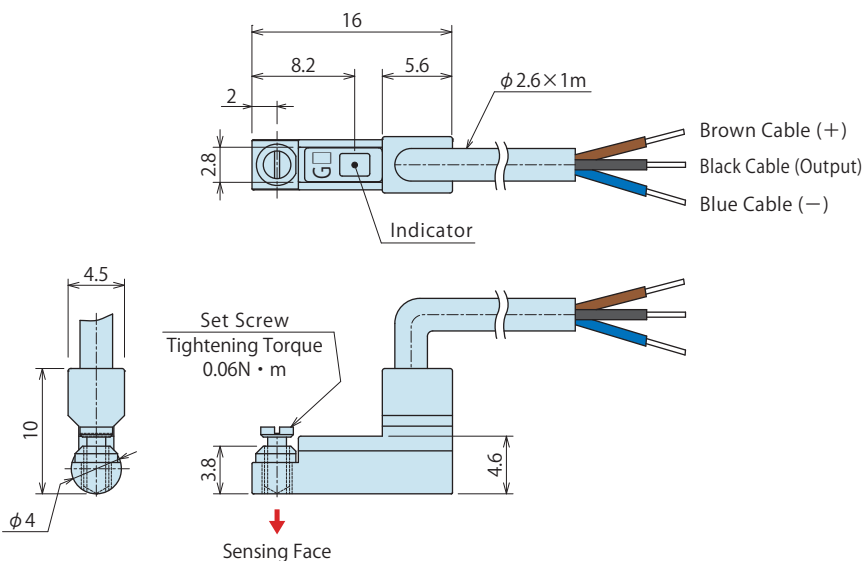

Locating + Clamp
Locating
Hand + Clamp
Support
Valve + Coupler
Cautions + Others
Pallet Gripper
WVA
Locating Pin Clamp
SWP
High-Power Pull Stud Clamp
WPT
JES
FA Pneumatic Hole Clamp
WKH
Lifting Hole Clamp
SWJ
Ball Lock Cylinder
WKA
Pneumatic Robotic Hands
WPW-C
WPS-C
WPA
WPH
WPP
WPQ
Auto Switch Proximity Switch
JEP
High-Power Pneumatic Hole Clamp
SWE
High-Power Pneumatic Swing Clamp
WHE
High-Power Pneumatic Link Clamp
WCE
Pneumatic Hole Clamp
SWA
Pneumatic Swing Clamp
WHA
Double Piston Pneumatic Swing Clamp
WHD
Pneumatic Link Clamp
WCA
Air Flow Control Valve
BZW
Manifold Block
WHZ-MD

Cautions

● Notes for Design

- 1) Check the Specifications
 - Please use each product according to the specifications. The product may be damaged or malfunction if used outside the range of load or specifications.
- 2) Notes on Use in the Interlock Circuit
 - When the sensor is used for an interlock signal that requires high reliability, please use a double interlock system by providing a mechanical protection function. Or by using another sensor together with the product. Also, please perform periodic maintenance and confirm proper operation.
- 3) Please avoid using loads that generate surge voltage.
 - If driving a relay, put a Zener diode in parallel for surge protection.

● Notes on Operating Environment

- 1) Never use the product in an atmosphere with explosive gases.
 - Sensor for Air Cylinder is not designed to prevent explosion. Do not use the product in an atmosphere with explosive gases since it may cause serious explosions.
- 2) The product may malfunction if an intense magnetic field is applied to a pole body.
- 3) Make sure to prepare shield measures when using in the following environments.
 - Where large current and/or strong magnetic field are generated.
 - Where noise occurs due to static electricity, etc.
 - Where magnetic powder or dust such as iron powder occurs or scatters.
- 4) Do not use the product in an environment where it is continuously exposed to coolant or chemical liquid.
 - Although IEC standard IP67 structure is satisfied, please avoid using sensors in an environment where continuously exposed to coolant or chemical liquid. This may cause insulation failure or malfunction.
- 5) Do not use the product in an environment with oil or chemicals.
 - If sensors are used in an environment with coolant or cleaning solvent, even in a short time, they may be adversely affected by improper insulation, malfunction due to swelling of potting resin and or hardening of electric cable.
- 6) Do not use the product in an environment with excessive vibrations or impacts.

● Installation Notes

- 1) Electric Wiring Reverse Connection Protection
 - Follow the electric circuit diagram on P.288 and make sure to connect properly. Never connect the power reversely.
- 2) Tighten sensors with appropriate tightening torque.
 - Use the set screw mounted on the sensor body and tighten it with the following torque.
JES0000 : 0.06N · m
- 3) Wiring
 - Do not damage the cables. Damaged, forcibly bended, stretched, winded, load applied or pinched cables will cause fire, electric shock, and/or malfunction due to electric leakage and/or continuity failure.
 - Do not apply excessive stress on the cable port of the sensor.
 - Minimum bending radius of the cable port is R7.
 - If cables are to move, fix the middle of the cables so that no stress is applied to the cable port.
- 4) Mounting position of the sensor should be adjusted by checking actual operating state.

● Notes on Handling

- 1) It should be operated by qualified personnel.
 - The hydraulic and pneumatic equipment should be operated and maintained by qualified personnel.
- 2) Do not operate or remove the product unless the safety protocols are ensured.
 - ① The machine and equipment can only be inspected or prepared when it is confirmed that the safety devices are in place.
 - ② Before the product is removed, make sure that the above-mentioned safety devices are in place. Shut off the pressure and power source, and make sure no pressure exists in the air and hydraulic circuits.
 - ③ After stopping the product, do not remove until the temperature drops.
 - ④ Make sure there is no trouble/issue in the bolts and respective parts before restarting the machine or equipment.
- 3) Do not disassemble or modify.
 - If the equipment is taken apart or modified, the warranty will be voided even within the warranty period. Never modify the product as it contains a powerful magnet.
- 4) Keep more than one meter away from this product if you have a heart pacemaker, etc. It may be malfunctioned by strong magnetism.
- 5) This sensor is made by ASA Electronics Industry Co. Ltd. Please contact us or ASA Electronics Industry for further inquiries.

● Maintenance and Inspection

- 1) Removal of the Product and Shut-off of Pressure Source
 - Before removing the product, make sure that safety devices and preventive devices are in place. Shut off the pressure and power source, and make sure no pressure exists in the air and hydraulic circuits.
 - Make sure there is no trouble/issue in the bolts and respective parts before restarting.
- 2) Never touch terminals while the power is on.
 - Otherwise it will cause electric shock, malfunction and damage to the sensor for air cylinder.
- 3) Retightening of Set Screw
 - When mounting position of the sensor for air cylinder is shifted due to looseness of set screw, retighten it after adjusting the mounting position.
- 4) Check if the electric cable is damaged or not.
 - Damaged cables may cause insulation failure. Replace a sensor for air cylinder or repair the reed if the electric cable is damaged.
- 5) Product Storage
 - The products should be stored in the cool and dark place without direct sunshine or moisture.

Locating + Clamp
Locating
Hand + Clamp
Support
Valve + Coupler
Cautions + Others
Pallet Gripper
WVA
Locating Pin Clamp
SWP
High-Power Pull Stud Clamp
WPT
JES
FA Pneumatic Hole Clamp
WKH
Lifting Hole Clamp
SWJ
Ball Lock Cylinder
WKA
Pneumatic Robotic Hands
WPW-C
WPS-C
WPA
WPH
WPP
WPQ
Auto Switch Proximity Switch
JEP
High-Power Pneumatic Hole Clamp
SWE
High-Power Pneumatic Swing Clamp
WHE
High-Power Pneumatic Link Clamp
WCE
Pneumatic Hole Clamp
SWA
Pneumatic Swing Clamp
WHA
Double Piston Pneumatic Swing Clamp
WHD
Pneumatic Link Clamp
WCA
Air Flow Control Valve
BZW
Manifold Block
WHZ-MD

※ Please refer to P.716 for common cautions. • Warranty

● Cautions

● Notes on Handling

- 1) It should be operated by qualified personnel.
 - The hydraulic machine and air compressor should be operated and maintained by qualified personnel.
- 2) Do not operate or remove the product unless the safety protocols are ensured.
 - ① The machine and equipment can only be inspected or prepared when it is confirmed that the safety devices are in place.
 - ② Before the product is removed, make sure that the above-mentioned safety devices are in place. Shut off the pressure and power source, and make sure no pressure exists in the air and hydraulic circuits.
 - ③ After stopping the product, do not remove until the temperature drops.
 - ④ Make sure there is no trouble/issue in the bolts and respective parts before restarting the machine or equipment.
- 3) Do not touch a clamp (cylinder) while it is working. Otherwise, your hands may be injured.

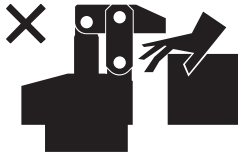

- 4) Do not disassemble or modify.
 - If the equipment is taken apart or modified, the warranty will be voided even within the warranty period.

● Maintenance and Inspection

- 1) Removal of the Machine and Shut-off of Pressure Source
 - Before removing the product, make sure that the safety devices are in place. Shut off the pressure and power source and make sure no pressure exists in the air and hydraulic circuits.
 - Make sure there is no trouble/issue in the bolts and respective parts before restarting.
- 2) Regularly clean the area around the piston rod and plunger.
 - If it is used when the surface is contaminated with dirt, it may lead to packing seal damage, malfunctioning, fluid leakage.

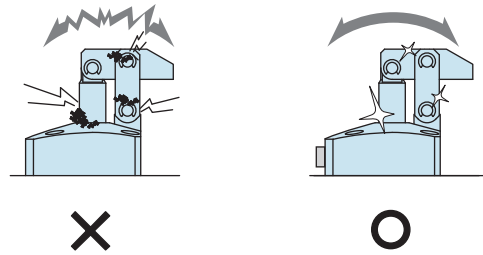

- 3) Regularly clean the reference surfaces (taper reference surface and seating surface) of locating products (SWT/SWQ/SWP/VRA/VRC/VX/VXE/VXF/WVS/VWH/VWM/VWK).
 - Locating products (except VRA/VRC/VX/VXE/VXF and SWR without air blow port) can remove contaminants with the cleaning function. When installing a workpiece or a pallet, make sure there are no contaminants such as thick sludge.
 - Continuous use with dirt on components will lead to locating failure, fluid leakage and malfunction.

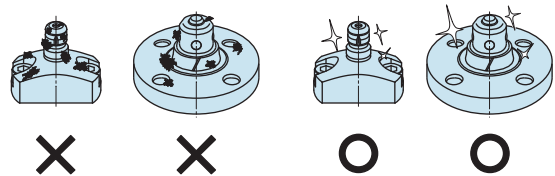

- 4) Regularly tighten pipe, mounting bolt, nut, snap ring, cylinder and others to ensure proper use.
- 5) Make sure the hydraulic fluid has not deteriorated.
- 6) Make sure there is a smooth action without an irregular noise.
 - Especially when it is restarted after left unused for a long period, make sure it can be operated correctly.
- 7) The products should be stored in the cool and dark place without direct sunshine or moisture.
- 8) Please contact us for overhaul and repair.

● Warranty

1) Warranty Period

- The product warranty period is 18 months from shipment from our factory or 12 months from initial use, whichever is earlier.

2) Warranty Scope

- If the product is damaged or malfunctions during the warranty period due to faulty design, materials or workmanship, we will replace or repair the defective part at our expense.

Defects or failures caused by the following are not covered.

- ① If the stipulated maintenance and inspection are not carried out.
- ② Failure caused by the use of the non-confirming state at the user's discretion.
- ③ If it is used or operated in an inappropriate way by the operator. (Including damage caused by the misconduct of the third party.)
- ④ If the defect is caused by reasons other than our responsibility.
- ⑤ If repair or modifications are carried out by anyone other than Kosmek, or without our approval and confirmation, it will void warranty.
- ⑥ Other caused by natural disasters or calamities not attributable to our company.
- ⑦ Parts or replacement expenses due to parts consumption and deterioration. (Such as rubber, plastic, seal material and some electric components.)

Damages excluding from direct result of a product defect shall be excluded from the warranty.

Locating
+
Clamp

Locating

Hand · Clamp

Support

Valve · Coupler

Cautions · Others

Cautions

Installation Notes

Maintenance/
Inspection

Warranty

Company Profile

Company Profile

Our Products

History

Index

Search by
Alphabetical Order

Sales Offices

Sales Offices

Sales Offices across the World

JAPAN HEAD OFFICE Overseas Sales	TEL. +81-78-991-5162	FAX. +81-78-991-8787
	KOSMEK LTD. 1-5, 2-chome, Murotani, Nishi-ku, Kobe-city, Hyogo, Japan 651-2241 〒651-2241 兵庫県神戸市西区室谷2丁目1番5号	
United States of America SUBSIDIARY KOSMEK (USA) LTD.	TEL. +1-630-620-7650	FAX. +1-630-620-9015
	650 Springer Drive, Lombard, IL 60148 USA	
MEXICO REPRESENTATIVE OFFICE KOSMEK USA Mexico Office	TEL. +52-442-161-2347	
	Av. Santa Fe #103 int 59 Col. Santa Fe Juriquilla C.P. 76230 Queretaro, Qro Mexico	
EUROPE SUBSIDIARY KOSMEK EUROPE GmbH	TEL. +43-463-287587	FAX. +43-463-287587-20
	Schleppeplatz 2 9020 Klagenfurt am Wörthersee Austria	
CHINA KOSMEK (CHINA) LTD. 考世美(上海)貿易有限公司	TEL. +86-21-54253000	FAX. +86-21-54253709
	Room601, RIVERSIDE PYRAMID No.55, Lane21, Pusan Rd, Pudong Shanghai 200125, China 中国上海市浦东新区浦三路21弄55号银亿滨江中心601室 200125	
INDIA BRANCH OFFICE KOSMEK LTD - INDIA	TEL. +91-9880561695	
	F 203, Level-2, First Floor, Prestige Center Point, Cunningham Road, Bangalore -560052 India	
THAILAND REPRESENTATIVE OFFICE KOSMEK Thailand Representation Office	TEL. +66-2-300-5132	FAX. +66-2-300-5133
	67 Soi 58, RAMA 9 Rd., Suanluang, Suanluang, Bangkok 10250, Thailand	
TAIWAN (Taiwan Exclusive Distributor) Full Life Trading Co., Ltd. 盈生貿易有限公司	TEL. +886-2-82261860	FAX. +886-2-82261890
	16F-4, No.2, Jian Ba Rd., Zhonghe District, New Taipei City Taiwan 23511 台湾新北市中和區建八路2號 16F-4 (遠東世紀廣場)	
PHILIPPINES (Philippines Exclusive Distributor) G.E.T. Inc, Phil.	TEL. +63-2-310-7286	FAX. +63-2-310-7286
	Victoria Wave Special Economic Zone Mt. Apo Building, Brgy. 186, North Caloocan City, Metro Manila, Philippines 1427	
INDONESIA (Indonesia Exclusive Distributor) PT. Yamata Machinery	TEL. +62-21-29628607	FAX. +62-21-29628608
	Delta Commercial Park I, Jl. Kenari Raya B-08, Desa Jayamukti, Kec. Cikarang Pusat Kab. Bekasi 17530 Indonesia	

Sales Offices in Japan

Head Office Osaka Sales Office Overseas Sales	TEL. 078-991-5162	FAX. 078-991-8787
	〒651-2241 兵庫県神戸市西区室谷2丁目1番5号	
Tokyo Sales Office	TEL. 048-652-8839	FAX. 048-652-8828
	〒331-0815 埼玉県さいたま市北区大成町4丁目81番地	
Nagoya Sales Office	TEL. 0566-74-8778	FAX. 0566-74-8808
	〒446-0076 愛知県安城市美園町2丁目10番地1	
Fukuoka Sales Office	TEL. 092-433-0424	FAX. 092-433-0426
	〒812-0006 福岡県福岡市博多区上牟田1丁目8-10-101	

Global Network

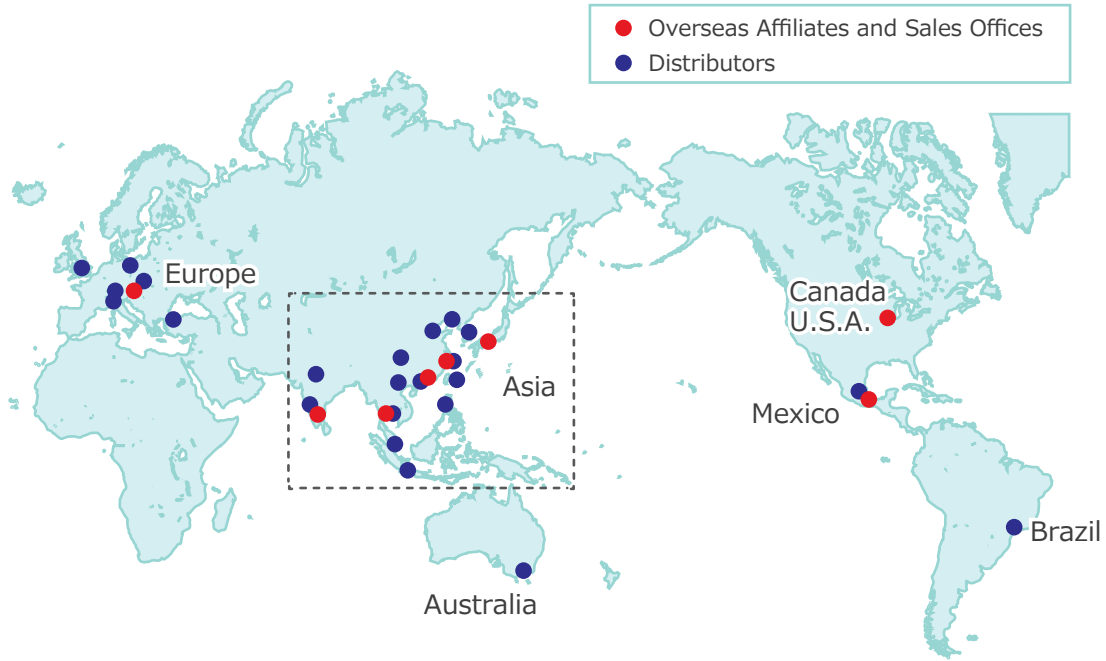

Asia Detailed Map



● FOR FURTHER INFORMATION ON UNLISTED SPECIFICATIONS AND SIZES, PLEASE CALL US.
● SPECIFICATIONS IN THIS CATALOG ARE SUBJECT TO CHANGE WITHOUT NOTICE.

