

Air Sequence Valve

Model BWD



Activates multiple air actuators in sequence.

PAT.

Delay time : 1 ~ 10 sec

Suitable for environment where the electric use is not allowed or when the number of ports is limited.

- **Best Suited for Machining Centers**

It controls the air flow by using a check valve, flow control valve, air tank, switching valve and activates multiple actuators in sequence. This has a compact and high performance sealing structure and can be built into fixtures for machining centers.

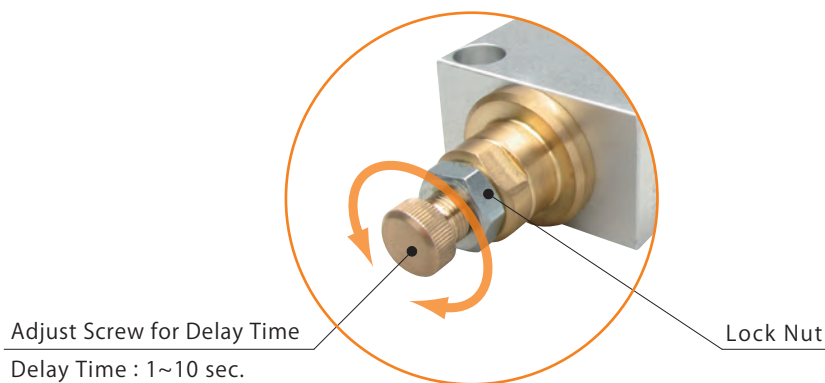

- **Electric control is not required.**

It can be installed in places where there is limited use of electricity such as explosion proof surroundings because electricity control is not required.

- **Air pilot port is not required.**

The actuators can be actuated with no air pilot port and minimum number of ports.

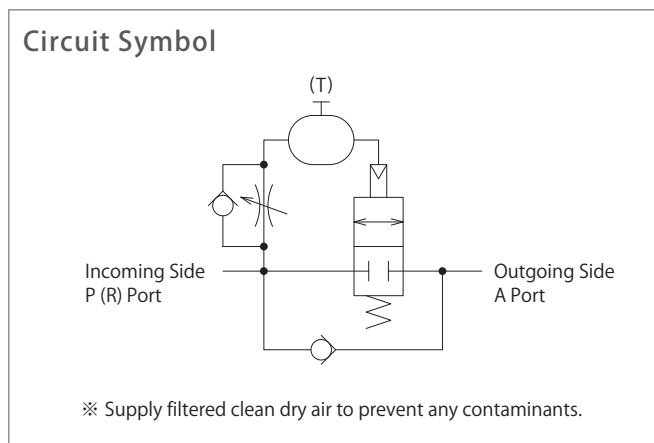

Action Description

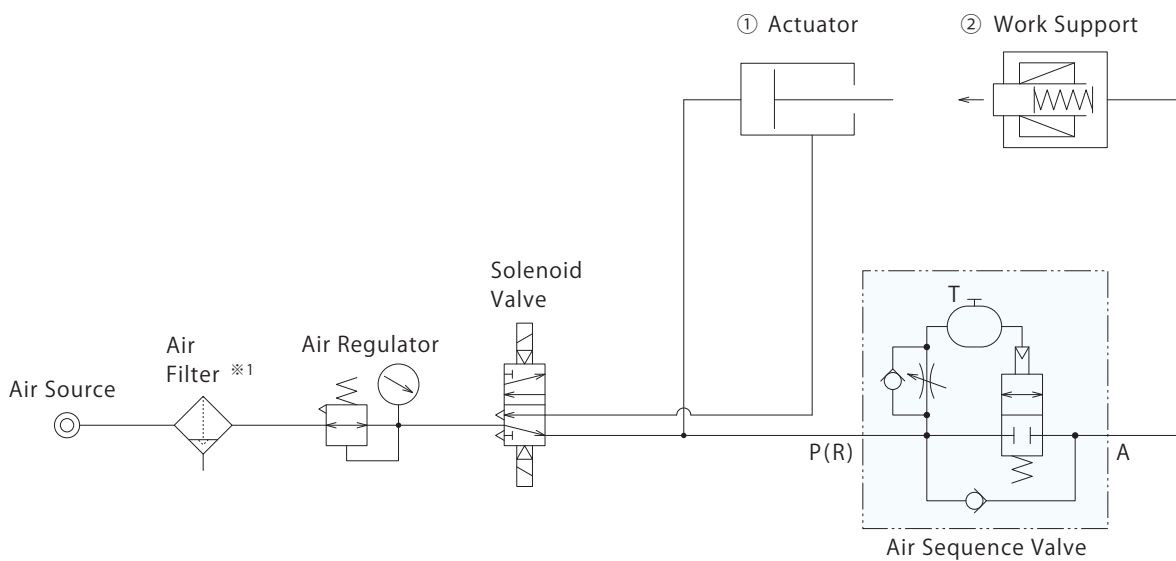
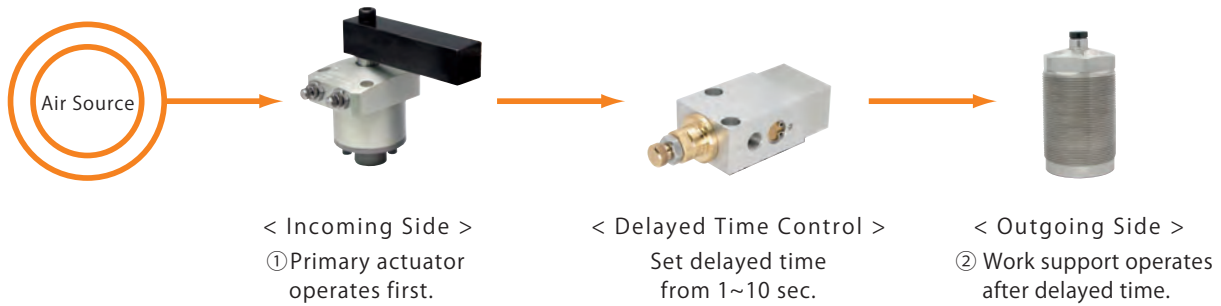

Note : *1. Supply filtered clean dry air to prevent any contaminants.

Operating Procedure		Note
Locking	Air pressure is ON.	
	Actuator ① is activated.	At this moment, Work Support ② is not activated.
	The built-in switching valve activates once the tank in the air sequence valve is full with air.	Delayed Time : 1 ~ 10sec
	Work Support ② is activated.	
	Locking action is completed.	
Machining Process, etc.		
Releasing	Air pressure is OFF.	
	Actuator ① and Work Support ② release at the same time.	
	Releasing action is completed.	

High-Power Series

Pneumatic Series

Hydraulic Series

Valve / Coupler Hydraulic Unit

Manual Operation Accessories

Cautions / Others

Air Sequence Valve

BWD

Hydraulic Non-Leak Coupler

BGA/BGB

BGC/BGD

BGP/BGS

BBP/BBS

BNP/BNS

BJP/BJS

BFP/BFS

Auto Coupler

JTA/JTB

JTC/JTD

JVA/JVB

JVC/JVD

JVE/JVF

JNA/JNB

JNC/JND

JLP/JLS

Rotary Joint

JR

Hydraulic Valve

BK

BEQ

BT

BLS/BLG

BLB

JSS/JS

JKA/JKB

BMA/BMG

AU/AU-M

BU

BP/JPB

BX

BEP/BSP

BH

BC

Air Hydraulic Unit

CV

CK

CP/CPB

CPC/CQC

CB

CC

AB/AB-V

AC/AC-V

Model No. Indication

BWD 010 0

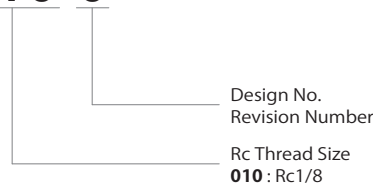

Specifications

Model No.	BWD0100	
Max. Operating Pressure	MPa	0.6
Min. Operating Pressure	MPa	0.2
Withstanding Pressure	MPa	1.5
Delayed Time ^{※1 ※2 ※3 ※4}	sec	1 ~ 10
Min. Passage Area	mm ²	4.0
Operating Temperature	°C	0 ~ 70
Usable Fluid		Dry Air
Weight	kg	0.2

Notes :

- ※1. Depending on the down time, the time delay of initial action may be longer.
- ※2. The time delay can be extended by adding a tank to T port and increasing its capacity.
- ※3. If actuators on the outgoing side do not operate after the time delayed setting, verify setting after pressure returns to zero.
- ※4. The confirmation for delayed time should be done after fastening the lock nut of the delayed time adjusting screw.
 1. Depending on the circuit condition, the pressure of incoming side might decrease during operation of outgoing actuators after directional control valve is switched.
 2. Prepare time gap of more than 5 seconds until air is supplied again after air supply stops (releases).
 3. Recommend the series connection if multiple valves are used in one circuit.

Performance Curve

(Adjusting Screw Turn Ratio and Time Delay at Various Operating Pressures)

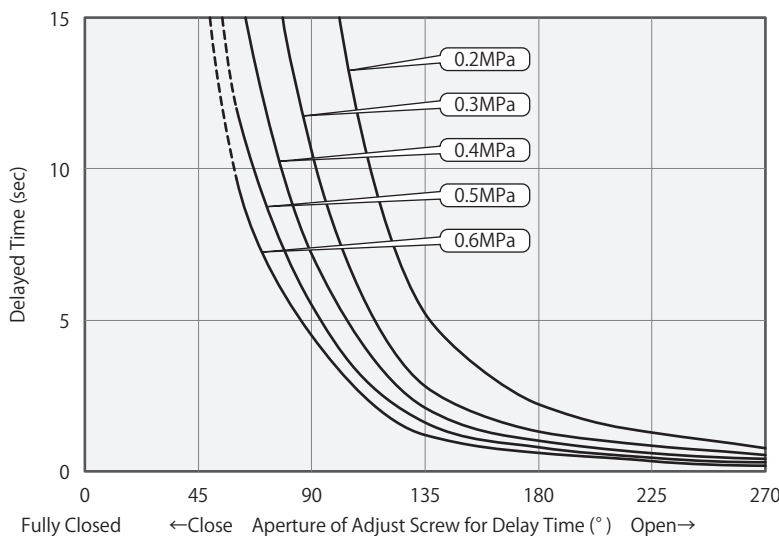

Notes :

1. This graph shows the relationship of the delayed time adjusting thread opening degree and the delayed time.
2. Depending on the circuit condition, the actual delayed time changes. (This graph should be for reference only.)

External Dimensions

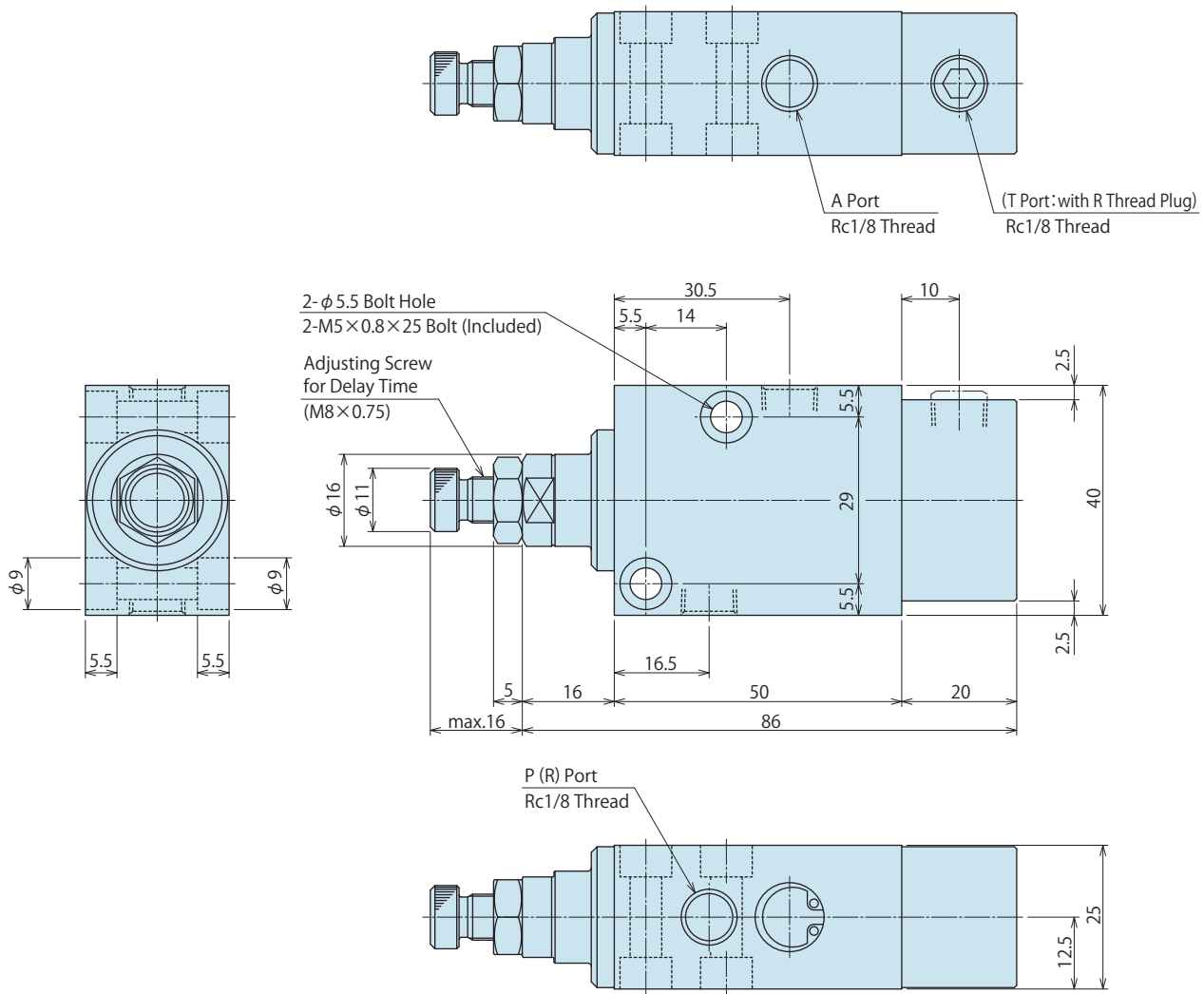

Note :

- Depending on the circuit condition, the actual delayed time changes.
Do not fasten the adjusting screw too tight or loosen it too much. The product may be damaged.

High-Power Series

Pneumatic Series

Hydraulic Series

Valve / Coupler Hydraulic Unit

Manual Operation Accessories

Cautions / Others

Air Sequence Valve

BWD

Hydraulic Non-Leak Coupler

BGA/BGB

BGC/BGD

BGP/BGS

BBP/BBS

BNP/BNS

BJP/BS

BFP/BFS

Auto Coupler

JTA/JTB

JTC/JTD

JVA/JVB

JVC/JVD

JVE/JVF

JNA/JNB

JNC/JND

JLP/JLS

Rotary Joint

JR

Hydraulic Valve

BK

BEQ

BT

BLS/BLG

BLB

JSS/JS

JKA/JKB

BMA/BMG

AU/AU-M

BU

BP/JPB

BX

BEP/BSP

BH

BC

Air Hydraulic Unit

CV

CK

CP/CPB

CPC/CQC

CB

CC

AB/AB-V

AC/AC-V

ⓘ Cautions

● Notes on Handling

- 1) It should be operated by qualified personnel.
 - The hydraulic machine and air compressor should be operated and maintained by qualified personnel.
- 2) Do not operate or remove the product unless the safety protocols are ensured.
 - ① The machine and equipment can only be inspected or prepared when it is confirmed that the safety devices are in place.
 - ② Before the product is removed, make sure that the above-mentioned safety devices are in place. Shut off the pressure and power source, and make sure no pressure exists in the air and hydraulic circuits.
 - ③ After stopping the product, do not remove until the temperature drops.
 - ④ Make sure there is no abnormality in the bolts and respective parts before restarting the machine or equipment.
- 3) Do not touch a clamp (cylinder) while it is working. Otherwise, your hands may be injured due to clinching.

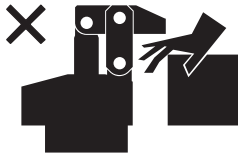

- 4) Do not disassemble or modify.
 - If the equipment is taken apart or modified, the warranty will be voided even within the warranty period.

● Maintenance and Inspection

- 1) Removal of the Machine and Shut-off of Pressure Source
 - Before the machine is removed, make sure that safety devices and preventive devices are in place. Shut off the pressure and power source, and make sure no pressure exists in the air and hydraulic circuits.
 - Make sure there is no abnormality in the bolts and respective parts before restarting.
- 2) Regularly clean the area around the piston rod and plunger.
 - If it is used when the surface is contaminated with dirt, it may lead to packing seal damage, malfunctioning and fluid leakage.

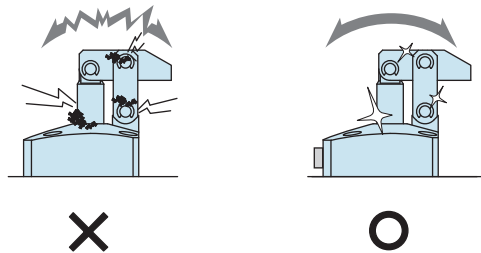

- 3) Please clean out the reference surfaces on a regular basis (taper reference surface and seating surface) of the locating products. (VS/VT/VFL/VFM/VFJ/VFK/WVS/VWM/VWK/VX/VXE/VXF)
 - The locating products, except VX/VXE/VXF model, can remove contaminants with cleaning functions. However, hardened cutting chips, adhesive coolant and others may not be removed. Make sure there are no contaminants before installing a workpiece/pallet.
 - Continuous use with contaminant on components will lead to locating accuracy failure, malfunction and fluid leakage.

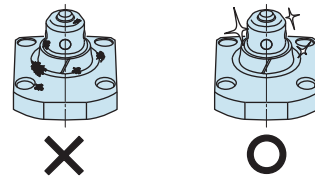

- 4) If disconnecting by couplers, air bleeding should be carried out on a regular basis to avoid air mixed in the circuit.
- 5) Regularly tighten nut, bolt, pin, cylinder, pipe line and others to ensure proper use.
- 6) Make sure the hydraulic fluid has not deteriorated.
- 7) Make sure there is a smooth action without an irregular noise.
 - Especially when it is restarted after left unused for a long period, make sure it can be operated correctly.
- 8) The products should be stored in the cool and dark place without direct sunshine or moisture.
- 9) Please contact us for overhaul and repair.

Cautions
[Installation Notes
\(For Hydraulic Series\)](#)
[Hydraulic Fluid List](#)
[Notes on Hydraulic Cylinder
Speed Control Circuit](#)
[Notes on Handling](#)
[Maintenance/
Inspection](#)
[Warranty](#)

Company Profile

[Company Profile](#)
[Our Products](#)
[History](#)

Index

[Search by
Alphabetical Order](#)

Sales Offices

● Warranty

1) Warranty Period

- The product warranty period is 18 months from shipment from our factory or 12 months from initial use, whichever is earlier.

2) Warranty Scope

- If the product is damaged or malfunctions during the warranty period due to faulty design, materials or workmanship, we will replace or repair the defective part at our expense.

Defects or failures caused by the following are not covered.

- ① If the stipulated maintenance and inspection are not carried out.
- ② If the product is used while it is not suitable for use based on the operator's judgment, resulting in defect.
- ③ If it is used or operated in an inappropriate way by the operator. (Including damage caused by the misconduct of the third party.)
- ④ If the defect is caused by reasons other than our responsibility.
- ⑤ If repair or modifications are carried out by anyone other than Kosmek, or without our approval and confirmation, it will void warranty.
- ⑥ Other caused by natural disasters or calamities not attributable to our company.
- ⑦ Parts or replacement expenses due to parts consumption and deterioration. (Such as rubber, plastic, seal material and some electric components.)

Damages excluding from direct result of a product defect shall be excluded from the warranty.

Sales Offices

Sales Offices across the World

JAPAN HEAD OFFICE Overseas Sales	TEL. +81-78-991-5162	FAX. +81-78-991-8787
	KOSMEK LTD. 1-5, 2-chome, Murotani, Nishi-ku, Kobe-city, Hyogo, Japan 651-2241 〒651-2241 兵庫県神戸市西区室谷2丁目1番5号	
United States of America SUBSIDIARY KOSMEK (USA) LTD.	TEL. +1-630-620-7650	FAX. +1-630-620-9015
	650 Springer Drive, Lombard, IL 60148 USA	
MEXICO REPRESENTATIVE OFFICE KOSMEK USA Mexico Office	TEL. +52-442-161-2347	
	Av. Santa Fe #103 int 59 Col. Santa Fe Juriquilla C.P. 76230 Queretaro, Qro Mexico	
EUROPE SUBSIDIARY KOSMEK EUROPE GmbH	TEL. +43-463-287587	FAX. +43-463-287587-20
	Schleppeplatz 2 9020 Klagenfurt am Wörthersee Austria	
CHINA KOSMEK (CHINA) LTD. 考世美(上海)貿易有限公司	TEL. +86-21-54253000	FAX. +86-21-54253709
	Room601, RIVERSIDE PYRAMID No.55, Lane21, Pusan Rd, Pudong Shanghai 200125, China 中国上海市浦东新区浦三路21弄55号银亿滨江中心601室 200125	
INDIA BRANCH OFFICE KOSMEK LTD - INDIA	TEL. +91-9880561695	
	F 203, Level-2, First Floor, Prestige Center Point, Cunningham Road, Bangalore -560052 India	
THAILAND REPRESENTATIVE OFFICE KOSMEK Thailand Representation Office	TEL. +66-2-300-5132	FAX. +66-2-300-5133
	67 Soi 58, RAMA 9 Rd., Suanluang, Suanluang, Bangkok 10250, Thailand	
TAIWAN (Taiwan Exclusive Distributor) Full Life Trading Co., Ltd. 盈生貿易有限公司	TEL. +886-2-82261860	FAX. +886-2-82261890
	16F-4, No.2, Jian Ba Rd., Zhonghe District, New Taipei City Taiwan 23511 台湾新北市中和區建八路2號 16F-4 (遠東世紀廣場)	
PHILIPPINES (Philippines Exclusive Distributor) G.E.T. Inc, Phil.	TEL. +63-2-310-7286	FAX. +63-2-310-7286
	Victoria Wave Special Economic Zone Mt. Apo Building, Brgy. 186, North Caloocan City, Metro Manila, Philippines 1427	
INDONESIA (Indonesia Exclusive Distributor) PT. Yamata Machinery	TEL. +62-21-29628607	FAX. +62-21-29628608
	Delta Commercial Park I, Jl. Kenari Raya B-08, Desa Jayamukti, Kec. Cikarang Pusat Kab. Bekasi 17530 Indonesia	

Sales Offices in Japan

Head Office Osaka Sales Office Overseas Sales	TEL. 078-991-5162	FAX. 078-991-8787
	〒651-2241 兵庫県神戸市西区室谷2丁目1番5号	
Tokyo Sales Office	TEL. 048-652-8839	FAX. 048-652-8828
	〒331-0815 埼玉県さいたま市北区大成町4丁目81番地	
Nagoya Sales Office	TEL. 0566-74-8778	FAX. 0566-74-8808
	〒446-0076 愛知県安城市美園町2丁目10番地1	
Fukuoka Sales Office	TEL. 092-433-0424	FAX. 092-433-0426
	〒812-0006 福岡県福岡市博多区上牟田1丁目8-10-101	

Global Network

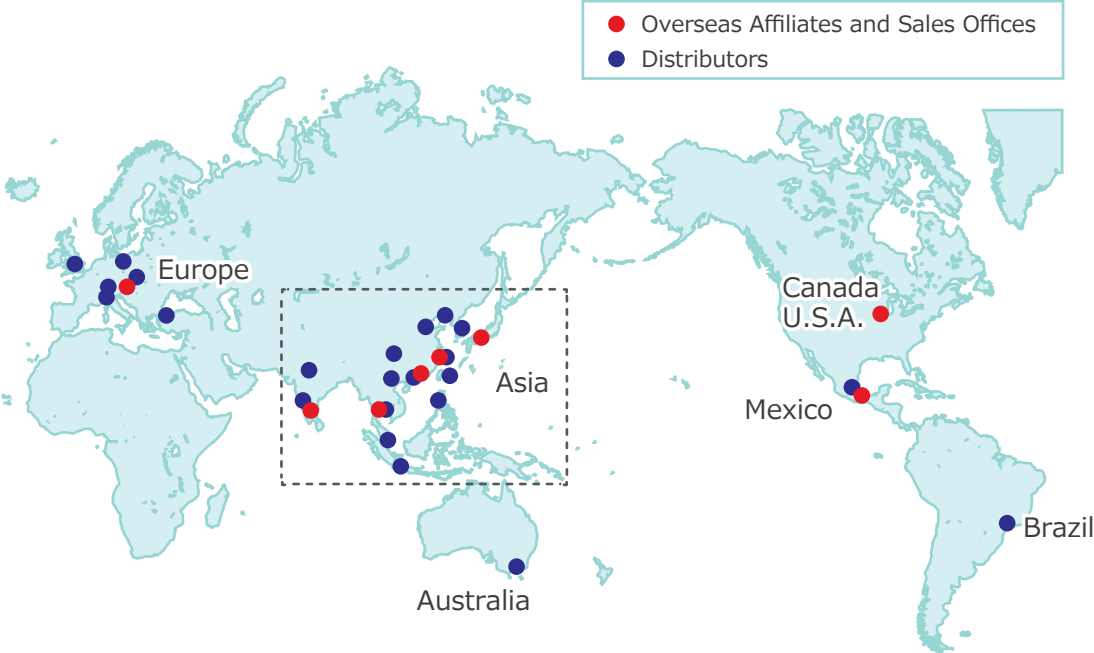

Asia Detailed Map



● FOR FURTHER INFORMATION ON UNLISTED SPECIFICATIONS AND SIZES, PLEASE CALL US.
● SPECIFICATIONS IN THIS CATALOG ARE SUBJECT TO CHANGE WITHOUT NOTICE.

