



# Compact cylinder—NACQ Series

## Compendium of NACQ Series

**In accordance with JIS standard**

**Magnetic switch slots around the cylinder body**  
There are magnetic switch slots around the cylinder body convenient to install inducting switch.

**Two kinds of rod type**

Female thread      Male thread

**Multi-mounting accessories**

FA Type      FB Type      LB Type      CB Type

**Ten bore size are available**  
Bore size: 12\16\20\25\32\40\50\63\80\100mm

**Multi-type cylinder**

|   |  |
|---|--|
| NACQ: Compact cylinder (Double acting)      |  |
| NASQ: Compact cylinder (Single acting-push) |  |
| NATQ: Compact cylinder (Single acting-pull) |  |
| NACQD: Compact cylinder (Double rod)        |  |

**Compact structure**  
C clip is adopted to connect the cylinder body and back cover or front cover, and riveted structure is adopted to connect piston and piston rod to make it compact and reliable.

**Convenient and fast fix sensor switch**  
Sensor can be directly fixed onto the groove of the cylinder, which is convenient and fast.  
the counterpart sensor type is: CMSH、DMSH(S)

## Installation and application



- When load changes in the work, the cylinder with abundant output capacity shall be selected.
- Relative cylinder with high temperature resistance or corrosion resistance shall be chosen under the condition of high temperature or corrosion.
- Necessary protection measure shall be taken in the environment with higher humidity, much dust or water drops, oil dust and welding dregs.
- Dirty substances in the pipe must be eliminated before cylinder is connected with pipeline to prevent the entrance of particles into the cylinder.
- The medium used by cylinder shall be filtered to 40µm or below.
- As both of the front cover and piston of the cylinder are short, typically too large stroke can not be selected.
- Anti-freezing measure shall be adopted under low temperature environment to prevent moisture freezing.
- The cylinder shall avoid the influence of side load in operation to maintain the normal work of cylinder and extend the service life.
- If the cylinder is dismantled and stored for a long time, please conduct anti-rust treatment to the surface.  
Anti-dust caps shall be added in air inlet and outlet ports. The front and back cover can not be dismantled, which shall be especially noticed.
- C clip Installation:
  - Removal & Installation of C clip must be done with proper tool & care.
  - Ensure C clip is securely fitted into the proper slot to prevent leakage.



# Compact cylinder

## NACQ Series



### Ordering code

**NACQ 20X30 S B □ T**

① ② ③ ④ ⑤ ⑥ ⑦

| ① Model                                     | ② Bore size                          | ③ Stroke                          | ④ Magnet                                | ⑤ Rod type                             | ⑥ Mounting type[Note1]  | ⑦ Thread type  |
|---|--------------------------------------|-----------------------------------|---|--|---|----------------|
| NACQ: Compact cylinder (Double acting)      | 12 16 20 25 32 40<br>50 63 80 100    | Refer to stroke table for details | Blank: Without magnet<br>S: With magnet | Blank: Female thread<br>B: Male thread | Blank: No accessories<br>FA: FA type<br>FB: FB type<br>CB: CB type<br>LB: LB type | T: NPT [Note2] |
| NASQ: Compact cylinder (Single acting-push) | 12 16 20 25<br>32 40 50 63           |                                   |   |  |   |                |
| NATQ: Compact cylinder (Single acting-pull) |                                      |                                   |   |  |   |                |
| NACQD: Compact cylinder (Double rod)        | 12 16 20 25<br>32 40 50 63<br>80 100 |                                   |   |  | Blank: No accessories<br>FA: FA type<br>FB: FB type<br>LB: LB type                |                |

[Note1] Please refer to page 184~186 for accessory parts.

[Note2]  $\Phi 12 \sim \Phi 25$  thread is #10-32UNF and is blank here.

### Stroke

| Bore size (mm) |               | Standard stroke (mm)                            | Max.std stroke (mm) | Max.stroke (mm) |             |
|----------------|---------------|---|---------------------|-----------------|-------------|
|                |               |   |                     | Standard        | With magnet |
| 12             | Double acting | 5 10 15 20 25 30 35 40 45 50                    | 50                  | 80              | 70          |
|                | Single acting | 5 10 15 20                                      | 20                  | -               | -           |
| 16             | Double acting | 5 10 15 20 25 30 35 40 45 50 55 60              | 60                  | 80              | 70          |
|                | Single acting | 5 10 15 20                                      | 20                  | -               | -           |
| 20 25          | Double acting | 5 10 15 20 25 30 35 40 45 50 60 70 75 80 90 100 | 100                 | 140             | 130         |
|                | Single acting | 5 10 15 20 25 30                                | 30                  | -               | -           |
| 32 40          | Double acting | 5 10 15 20 25 30 35 40 45 50 60 70 75 80 90 100 | 100                 | 100             | 100         |
|                | Single acting | 5 10 15 20 25 30                                |                     |                 |             |
| 50 63          | Double acting | 5 10 15 20 25 30 35 40 45 50 60 70 75 80 90 100 | 100                 |                 |             |
|                | Single acting | 5 10 15 20 25 30                                |                     |                 |             |
| 80 100         | Double acting | 5 10 15 20 25 30 35 40 45 50 60 70 75 80 90 100 | 100                 | -               | -           |
|                | Single acting | 5 10 15 20 25 30                                |                     |                 |             |

Note) 1. Please contact the company for other special strokes.

2. The dimensions of non-std stroke cylinder has the same dimensions as the next longer stroke std. stroke cylinder.

e.g. 23mm stroke cylinder has the same dimensions of 25 std. stroke cylinder.

### Specification

| Bore size(mm)       | 12   | 16 | 20 | 25 | 32     | 40                    | 50     | 63 | 80     | 100 |
|---------------------|--|----|----|----|--------|-----------------------|--------|----|--------|-----|
| Acting type         | Double acting  |    |    |    |        |                       |        |    |        |     |
|                     | Single acting_Push type, Single acting_Pull type                           |    |    |    |        |                       |        |    |        | -   |
| Fluid               | Air(to be filtered by 40 $\mu$ m filter element)                           |    |    |    |        |                       |        |    |        |     |
| Operating pressure  | Double acting: 22~145psi(0.15~1.0MPa) Single acting: 28~145psi(0.2~1.0MPa) |    |    |    |        |                       |        |    |        |     |
| Proof pressure      | 215psi(1.5MPa)   |    |    |    |        |                       |        |    |        |     |
| Temperature         | -5°F~160°F(-20°C~70°C)   |    |    |    |        |                       |        |    |        |     |
| Speed range mm/s    | Double acting: 30~500  |    |    |    |        | Single acting: 50~500 |        |    |        |     |
| Stroke tolerance mm | $\begin{matrix} +1.0 \\ 0 \end{matrix}$                                    |    |    |    |        |                       |        |    |        |     |
| Cushion type        | Bumper   |    |    |    |        |                       |        |    |        |     |
| Port size           | #10-32UNF  |    |    |    | NPT1/8 |                       | NPT1/4 |    | NPT3/8 |     |

Add) Refer to P427 for detail of sensor switch.



## NACQ Series

### Product feature

1. JIS standard is implemented.
2. C clip is adopted to connect the cylinder body and back cover or front cover, and riveted structure is adopted to connect piston and piston rod to make it compact and reliable.
3. The internal diameter of the body is treated with rolling followed by the treatment of hard anodizing, forming an excellent abrasion resistance and durability.
4. The seal of piston adopts heterogeneous two-way seal structure. It has compact dimension and the function of grease reservation.
5. Compact structure can effectively save installation space.
6. There are magnetic switch slots around the cylinder body, which is convenient to install inducting switch.
7. Installing accessories with various specifications are optional.

### Criteria for selection: Cylinder thrust

Unit: Newton(N)

| Bore size(mm) | Rod size(mm) | Acting type   |           | Pressure area(mm <sup>2</sup> ) | Operating pressure(psi) |        |        |        |        |        |        |
|---------------|--------------|---------------|-----------|---------------------------------|-------------------------|--------|--------|--------|--------|--------|--------|
|               |              |               |           |                                 | 15                      | 30     | 45     | 60     | 75     | 90     | 105    |
| 12            | 6            | Single acting | Push side | 113.1                           | -                       | 13.6   | 24.9   | 36.2   | 47.5   | 58.9   | 70.2   |
|               |              |               | Pull side | 84.8                            | -                       | 8.0    | 16.4   | 24.9   | 33.4   | 41.9   | 50.4   |
|               |              | Double acting | Push side | 113.1                           | 11.3                    | 22.6   | 33.9   | 45.2   | 56.5   | 67.9   | 79.2   |
|               |              |               | Pull side | 84.8                            | 8.5                     | 17.0   | 25.4   | 33.9   | 42.4   | 50.9   | 59.4   |
| 16            | 8            | Single acting | Push side | 201.1                           | -                       | 27.0   | 47.1   | 67.2   | 87.3   | 107.4  | 127.5  |
|               |              |               | Pull side | 150.8                           | -                       | 17.0   | 32.0   | 47.1   | 62.2   | 77.3   | 92.4   |
|               |              | Double acting | Push side | 201.1                           | 20.1                    | 40.2   | 60.3   | 80.4   | 100.5  | 120.6  | 140.7  |
|               |              |               | Pull side | 150.8                           | 15.1                    | 30.2   | 45.2   | 60.3   | 75.4   | 90.5   | 105.6  |
| 20            | 10           | Single acting | Push side | 314.2                           | -                       | 36.8   | 68.2   | 99.7   | 131.1  | 162.5  | 193.9  |
|               |              |               | Pull side | 235.6                           | -                       | 21.1   | 44.7   | 68.2   | 91.8   | 115.4  | 138.9  |
|               |              | Double acting | Push side | 314.2                           | 31.4                    | 62.8   | 94.2   | 125.7  | 157.1  | 188.5  | 219.9  |
|               |              |               | Pull side | 235.6                           | 23.6                    | 47.1   | 70.7   | 94.2   | 117.8  | 141.4  | 164.9  |
| 25            | 12           | Single acting | Push side | 490.9                           | 18.1                    | 67.2   | 116.3  | 165.3  | 214.4  | 263.5  | 312.6  |
|               |              |               | Pull side | 377.8                           | 6.8                     | 44.6   | 82.3   | 120.1  | 157.9  | 195.7  | 233.4  |
|               |              | Double acting | Push side | 490.9                           | 49.1                    | 98.2   | 147.3  | 196.3  | 245.4  | 294.5  | 343.6  |
|               |              |               | Pull side | 377.8                           | 37.8                    | 75.6   | 113.3  | 151.1  | 188.9  | 226.7  | 264.4  |
| 32            | 16           | Single acting | Push side | 804.2                           | 27.4                    | 107.8  | 188.3  | 268.7  | 349.1  | 429.5  | 510.0  |
|               |              |               | Pull side | 603.2                           | 7.3                     | 67.6   | 128.0  | 188.3  | 248.6  | 308.9  | 369.2  |
|               |              | Double acting | Push side | 804.2                           | 80.4                    | 160.8  | 241.3  | 321.7  | 402.1  | 482.5  | 563.0  |
|               |              |               | Pull side | 603.2                           | 60.3                    | 120.6  | 181.0  | 241.3  | 301.6  | 361.9  | 422.2  |
| 40            | 16           | Single acting | Push side | 1256.6                          | 44.7                    | 170.3  | 296.0  | 421.7  | 547.3  | 673.0  | 798.6  |
|               |              |               | Pull side | 1055.6                          | 24.6                    | 130.1  | 235.7  | 341.2  | 446.8  | 552.3  | 657.9  |
|               |              | Double acting | Push side | 1256.6                          | 125.7                   | 251.3  | 377.0  | 502.7  | 628.3  | 754.0  | 879.6  |
|               |              |               | Pull side | 1055.6                          | 105.6                   | 211.1  | 316.7  | 422.2  | 527.8  | 633.3  | 738.9  |
| 50            | 20           | Single acting | Push side | 1963.5                          | 96.3                    | 292.7  | 489.0  | 685.4  | 881.7  | 1078.1 | 1274.4 |
|               |              |               | Pull side | 1649.3                          | 64.9                    | 229.9  | 394.8  | 559.7  | 724.7  | 889.6  | 1054.5 |
|               |              | Double acting | Push side | 1963.5                          | 196.3                   | 392.7  | 589.0  | 785.4  | 981.7  | 1178.1 | 1374.4 |
|               |              |               | Pull side | 1649.3                          | 164.9                   | 329.9  | 494.8  | 659.7  | 824.7  | 989.6  | 1154.5 |
| 63            | 20           | Single acting | Push side | 3117.2                          | 141.7                   | 453.4  | 765.2  | 1076.9 | 1388.6 | 1700.3 | 2012.1 |
|               |              |               | Pull side | 2803.1                          | 110.3                   | 390.6  | 670.9  | 951.2  | 1231.5 | 1511.9 | 1792.2 |
|               |              | Double acting | Push side | 3117.2                          | 311.7                   | 623.4  | 935.2  | 1246.9 | 1558.6 | 1870.3 | 2182.1 |
|               |              |               | Pull side | 2803.1                          | 280.3                   | 560.6  | 840.9  | 1121.2 | 1401.5 | 1681.9 | 1962.2 |
| 80            | 25           | Double acting | Push side | 5026.5                          | 502.7                   | 1005.3 | 1508.0 | 2010.6 | 2513.3 | 3015.9 | 3518.6 |
|               |              |               | Pull side | 4535.7                          | 453.6                   | 907.1  | 1360.7 | 1814.3 | 2267.8 | 2721.4 | 3175.0 |
| 100           | 32           | Double acting | Push side | 7854.0                          | 785.4                   | 1570.8 | 2356.2 | 3141.6 | 3927.0 | 4712.4 | 5497.8 |
|               |              |               | Pull side | 7049.7                          | 705.0                   | 1409.9 | 2114.9 | 2819.9 | 3524.9 | 4229.8 | 4934.8 |

# Compact cylinder

## NACQ Series

### Dimensions

#### NACQ

Φ12, Φ16

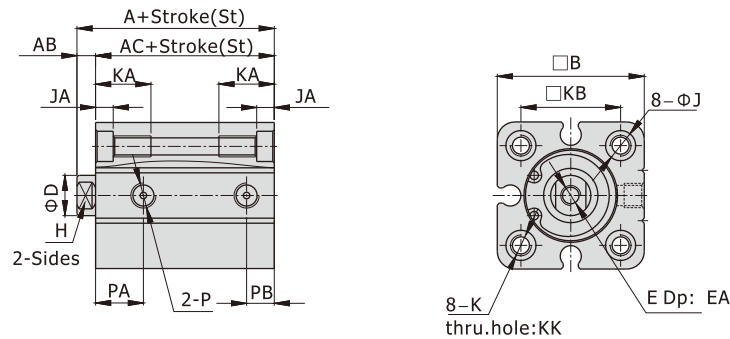

Φ20, Φ25

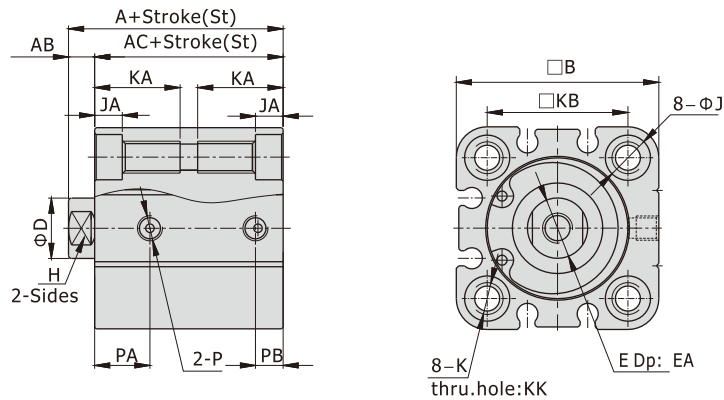

[Unit: mm]

| Type           | Without magnet |       |       |       |       |       | With magnet |      | AB  | B  | D  | EA | J | JA  | KK   | KA | KB   | PA  | PB  |
|----------------|----------------|-------|-------|-------|-------|-------|-------------|------|-----|----|----|----|---|-----|------|----|------|-----|-----|
|                | A              |       | AC    |       |       |       | A           | AC   |     |    |    |    |   |     |      |    |      |     |     |
| Bore size\Item | St≤50          | St=55 | St≥60 | St≤50 | St=55 | St≥60 | A           | AC   |     |    |    |    |   |     |      |    |      |     |     |
| 12             | 20.5           | -     | -     | 17    | -     | -     | 30.5        | 27   | 3.5 | 25 | 6  | 6  | 6 | 3.5 | Φ3.4 | 11 | 15.5 | 7.5 | 5   |
| 16             | 22             | 22    | -     | 18.5  | 18.5  | -     | 32          | 28.5 | 3.5 | 29 | 8  | 6  | 6 | 3.5 | Φ3.4 | 11 | 20   | 8   | 5.5 |
| 20             | 24             | -     | 34    | 19.5  | -     | 29.5  | 34          | 29.5 | 4.5 | 36 | 10 | 8  | 9 | 5.5 | Φ5.2 | 17 | 25.5 | 9   | 5.5 |
| 25             | 27.5           | -     | 37.5  | 22.5  | -     | 32.5  | 37.5        | 32.5 | 5   | 40 | 12 | 10 | 9 | 5.5 | Φ5.2 | 17 | 28   | 11  | 5.5 |

[Unit: Inch]

| Bore size(mm)\Item | E          | K          | P          | H    |
|--------------------|------------|------------|------------|------|
| 12                 | #8-32 UNC  | #8-32 UNC  | #10-32 UNF | 3/16 |
| 16                 | #8-32 UNC  | #8-32 UNC  | #10-32 UNF | 1/4  |
| 20                 | #10-32 UNF | 1/4-20 UNC | #10-32 UNF | 5/16 |
| 25                 | 1/4-28 UNF | 1/4-20 UNC | #10-32 UNF | 3/8  |

# Compact cylinder

## NACQ Series

Φ32~Φ100 (Stroke≤100)

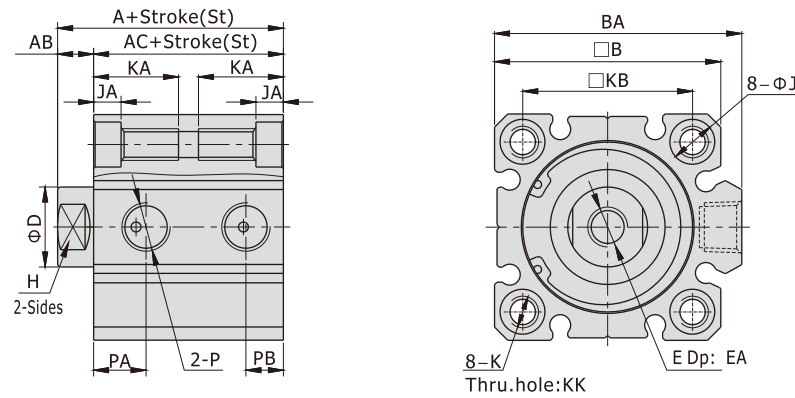

[Unit: mm]

| Item<br>Bore size | A(Without magnet) |       | A<br>(With magnet) | AB | AC(Without magnet) |       | AC<br>(With magnet) | B   | BA    | D  | EA | J    | JA  | KK    | KA   | KB |
|-------------------|-------------------|-------|--------------------|----|--------------------|-------|---------------------|-----|-------|----|----|------|-----|-------|------|----|
|                   | St≤50             | St≥60 |                    |    | St≤50              | St≥60 |                     |     |       |    |    |      |     |       |      |    |
| 32                | 30                | 40    | 40                 | 7  | 23                 | 33    | 33                  | 45  | 49.5  | 16 | 13 | 9    | 5.5 | Φ5.2  | 17   | 34 |
| 40                | 36.5              | 46.5  | 46.5               | 7  | 29.5               | 39.5  | 39.5                | 53  | 57    | 16 | 15 | 9    | 5.5 | Φ5.2  | 17   | 40 |
| 50                | 38.5              | 48.5  | 48.5               | 8  | 30.5               | 40.5  | 40.5                | 64  | 71    | 20 | 18 | 10.5 | 6.5 | Φ6.7  | 22.5 | 50 |
| 63                | 44                | 54    | 54                 | 8  | 36                 | 46    | 46                  | 77  | 84    | 20 | 18 | 14   | 9   | Φ8.5  | 28.5 | 60 |
| 80                | 53.5              | 63.5  | 63.5               | 10 | 43.5               | 53.5  | 53.5                | 98  | 104   | 25 | 20 | 17   | 11  | Φ10.4 | 35.5 | 77 |
| 100               | 65                | 75    | 75                 | 12 | 53                 | 63    | 63                  | 117 | 123.5 | 32 | 26 | 17   | 11  | Φ10.4 | 35.5 | 94 |

| Item<br>Bore size | Without magnet |      | With magnet |      |      |
|-------------------|----------------|------|-------------|------|------|
|                   | PA             | PB   | PA          | PB   |      |
| 32                | St=5           | 7.5  | 6.5         | 10.5 | 7.5  |
|                   | St>5           | 10.5 | 7.5         |      |      |
| 40                |                | 11   | 8           | 11   | 8    |
| 50                | St=5           | 9    | 9           | 10.5 | 10.5 |
|                   | St>5           | 10.5 | 10.5        |      |      |
| 63                | St=5           | 14   | 9.5         | 15   | 10.5 |
|                   | St>5           | 15   | 10.5        |      |      |
| 80                |                | 16   | 14          | 16   | 14   |
| 100               |                | 20   | 17.5        | 20   | 17.5 |

[Unit: Inch]

| Item<br>Bore size(mm) | E           | K           | P      | H      |
|-----------------------|-------------|-------------|--------|--------|
| 32                    | 5/16-24 UNF | 1/4-20 UNC  | NPT1/8 | 9/16   |
| 40                    | 3/8-24 UNF  | 1/4-20 UNC  | NPT1/8 | 9/16   |
| 50                    | 1/2-20 UNF  | 5/16-18 UNC | NPT1/4 | 11/16  |
| 63                    | 1/2-20 UNF  | 7/16-14 UNC | NPT1/4 | 11/16  |
| 80                    | 5/18-18 UNF | 1/2-13 UNC  | NPT3/8 | 7/8    |
| 100                   | 3/4-16 UNF  | 1/2-13 UNC  | NPT3/8 | 1-1/16 |

Note) The dimensions of non-std stroke cylinder has the same dimensions as the next longer stroke std. stroke cylinder.  
e.g. 55mm stroke cylinder has the same dimensions of 60 std. stroke cylinder.

### Male thread

(Bore size: Φ12~Φ100, Stroke≤100)

[Unit: mm]

[Unit: Inch]

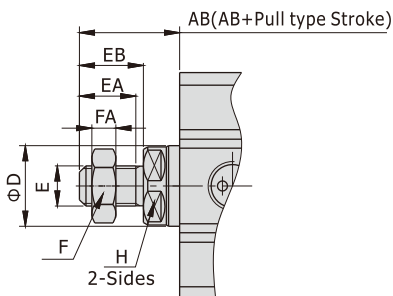

| Bore size\Item | AB   | D  | EA   | EB  |
|----------------|------|----|------|-----|
| 12             | 11.5 | 6  | 6.5  | 7.5 |
| 16             | 11.5 | 8  | 6.5  | 7.5 |
| 20             | 12.5 | 10 | 6.5  | 7.5 |
| 25             | 14.5 | 12 | 7.5  | 9   |
| 32             | 19.5 | 16 | 12   | 13  |
| 40             | 23   | 16 | 14   | 16  |
| 50             | 27.5 | 20 | 19   | 20  |
| 63             | 27.5 | 20 | 19   | 20  |
| 80             | 35.5 | 25 | 25   | 26  |
| 100            | 40.5 | 32 | 27.5 | 29  |

| Item<br>Bore size(mm) | E           | F     | FA   | H      |
|-----------------------|-------------|-------|------|--------|
| 12                    | #8-32 UNC   | 11/32 | 0.13 | 3/16   |
| 16                    | #8-32 UNC   | 11/32 | 0.13 | 1/4    |
| 20                    | #10-32 UNF  | 3/8   | 0.13 | 5/16   |
| 25                    | 1/4-28 UNF  | 7/16  | 0.16 | 3/8    |
| 32                    | 5/16-24 UNF | 1/2   | 0.19 | 9/16   |
| 40                    | 3/8-24 UNF  | 9/16  | 0.22 | 9/16   |
| 50                    | 1/2-20 UNF  | 3/4   | 0.31 | 11/16  |
| 63                    | 1/2-20 UNF  | 3/4   | 0.31 | 11/16  |
| 80                    | 5/18-18 UNF | 15/16 | 0.38 | 7/8    |
| 100                   | 3/4-16 UNF  | 1-1/8 | 0.42 | 1-1/16 |

# Compact cylinder

## NACQ Series

### NASQ NATQ

Φ12, Φ16

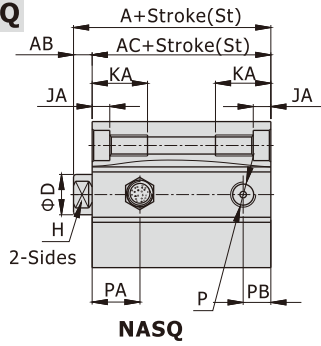

**NASQ**

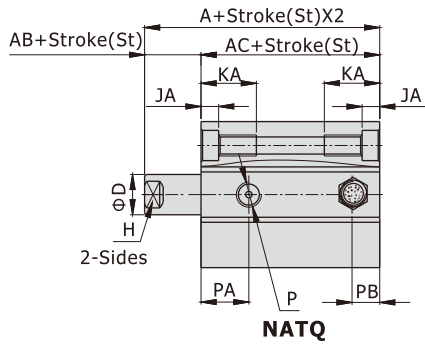

**NATQ**

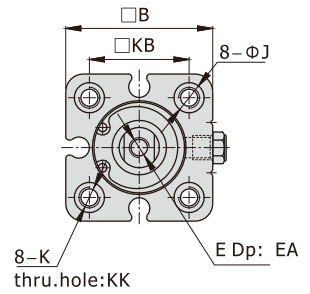

Φ20, Φ25

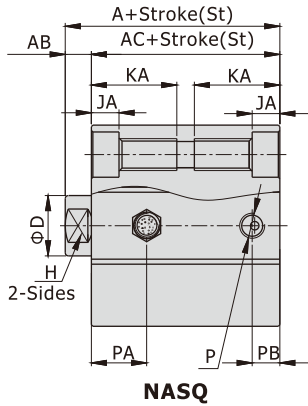

**NASQ**

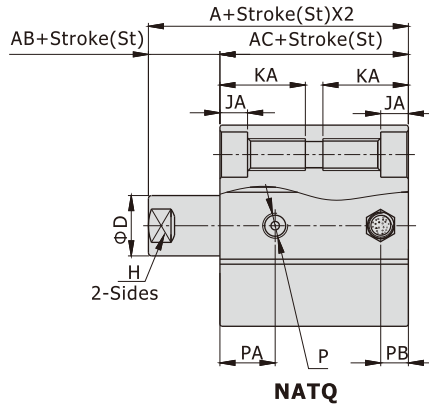

**NATQ**

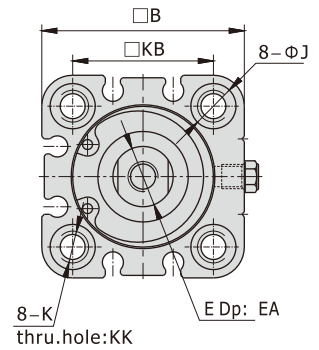

Φ32-Φ63

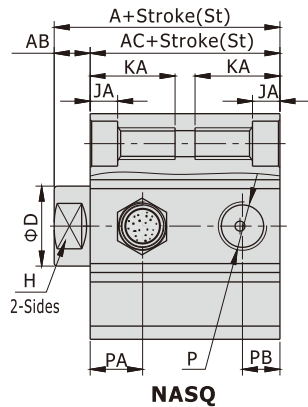

**NASQ**

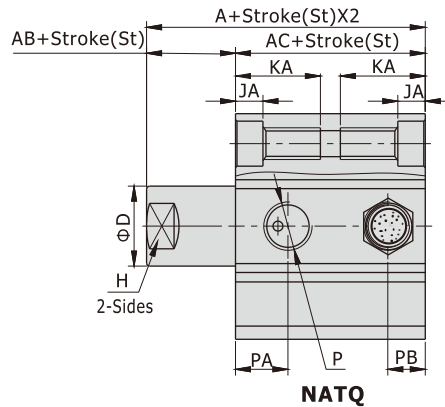

**NATQ**

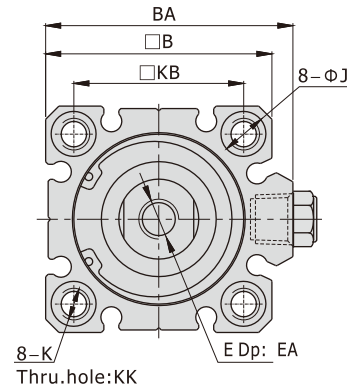

[Unit: mm]

| Bore size\Item | A(Without magnet) |       |       | A(With magnet) |       |       | AB  | AC(Without magnet) |       |       | AC(With magnet) |       |       | B  | BA   | D  | EA | J    | JA  |
|----------------|-------------------|-------|-------|----------------|-------|-------|-----|--------------------|-------|-------|-----------------|-------|-------|----|------|----|----|------|-----|
|                | 5\10              | 15\20 | 25\30 | 5\10           | 15\20 | 25\30 |     | 5\10               | 15\20 | 25\30 | 5\10            | 15\20 | 25\30 |    |      |    |    |      |     |
| 12             | 25.5              | 30.5  | -     | 35.5           | 40.5  | -     | 3.5 | 22                 | 27    | -     | 32              | 37    | -     | 25 | -    | 6  | 6  | 6    | 3.5 |
| 16             | 27                | 32    | -     | 37             | 42    | -     | 3.5 | 23.5               | 28.5  | -     | 33.5            | 38.5  | -     | 29 | -    | 8  | 6  | 6    | 3.5 |
| 20             | 29                | 34    | 39    | 39             | 44    | 49    | 4.5 | 24.5               | 29.5  | 34.5  | 34.5            | 39.5  | 44.5  | 36 | -    | 10 | 8  | 9    | 5.5 |
| 25             | 32.5              | 37.5  | 42.5  | 42.5           | 47.5  | 52.5  | 5   | 27.5               | 32.5  | 37.5  | 37.5            | 42.5  | 47.5  | 40 | -    | 12 | 10 | 9    | 5.5 |
| 32             | 35                | 40    | 45    | 45             | 50    | 55    | 7   | 28                 | 33    | 38    | 38              | 43    | 48    | 45 | 49.5 | 16 | 13 | 9    | 5.5 |
| 40             | 41.5              | 46.5  | 51.5  | 51.5           | 56.5  | 61.5  | 7   | 34.5               | 39.5  | 44.5  | 44.5            | 49.5  | 54.5  | 53 | 57   | 16 | 15 | 9    | 5.5 |
| 50             | 48.5              | 53.5  | 58.5  | 58.5           | 63.5  | 68.5  | 8   | 40.5               | 45.5  | 50.5  | 50.5            | 55.5  | 60.5  | 64 | 71   | 20 | 18 | 10.5 | 6.5 |
| 63             | 54                | 59    | 64    | 64             | 69    | 74    | 8   | 46                 | 51    | 56    | 56              | 61    | 66    | 77 | 84   | 20 | 18 | 14   | 9   |

| Bore size\Item | KK   | KA   | KB   | PA   | PB   |
|----------------|------|------|------|------|------|
| 12             | Φ3.4 | 11   | 15.5 | 7.5  | 5    |
| 16             | Φ3.4 | 11   | 20   | 8    | 5.5  |
| 20             | Φ5.2 | 17   | 25.5 | 9    | 5.5  |
| 25             | Φ5.2 | 17   | 28   | 11   | 5.5  |
| 32             | Φ5.2 | 17   | 34   | 10.5 | 7.5  |
| 40             | Φ5.2 | 17   | 40   | 11   | 8    |
| 50             | Φ6.6 | 22.5 | 50   | 10.5 | 10.5 |
| 63             | Φ9.4 | 28.5 | 60   | 15   | 10.5 |

[Unit: Inch]

| Bore size(mm)\Item | E           | K           | P          | H     |
|--------------------|-------------|-------------|------------|-------|
| 12                 | #8-32 UNC   | #8-32 UNC   | #10-32 UNF | 3/16  |
| 16                 | #8-32 UNC   | #8-32 UNC   | #10-32 UNF | 1/4   |
| 20                 | #10-32 UNF  | 1/4-20 UNC  | #10-32 UNF | 5/16  |
| 25                 | 1/4-28 UNF  | 1/4-20 UNC  | #10-32 UNF | 3/8   |
| 32                 | 5/16-24 UNF | 1/4-20 UNC  | NPT1/8     | 9/16  |
| 40                 | 3/8-24 UNF  | 1/4-20 UNC  | NPT1/8     | 9/16  |
| 50                 | 1/2-20 UNF  | 5/16-18 UNC | NPT1/4     | 11/16 |
| 63                 | 1/2-20 UNF  | 7/16-14 UNC | NPT1/4     | 11/16 |



# Compact cylinder

## NACQ Series

### NACQD

Φ12, Φ16

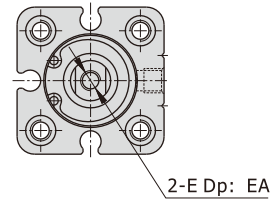
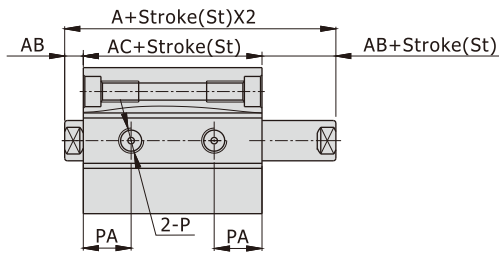

Φ20, Φ25

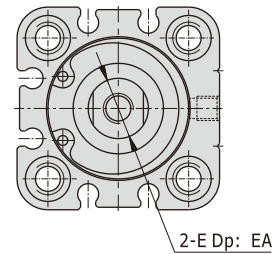
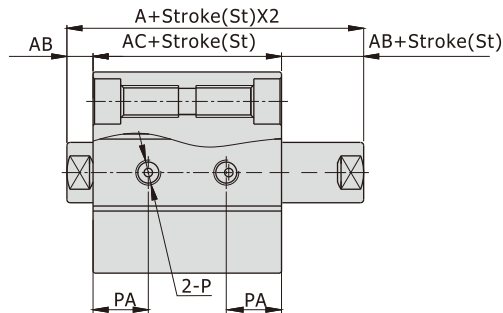

Φ32~Φ100

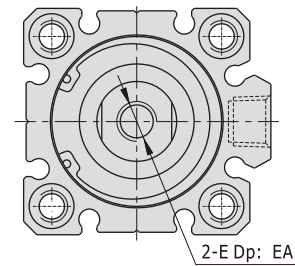
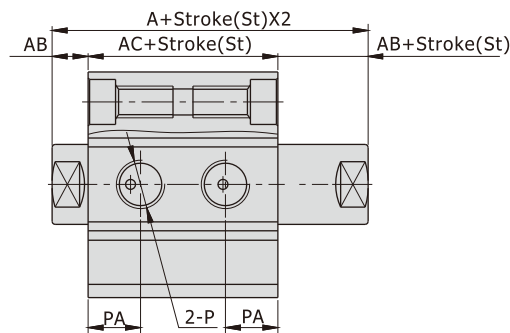

| Item<br>Bore size | Without magnet |      | With magnet |      | [Unit: mm] |      |                     |                     | [Unit: Inch]          |             |
|-------------------|----------------|------|-------------|------|------------|------|---------------------|---------------------|-----------------------|-------------|
|                   | A              | AC   | A           | AC   | AB         | AF   | EA                  | PA                  | Item<br>Bore size(mm) | E           |
| 12                | 32.2           | 25.2 | 42.2        | 35.2 | 3.5        | 17   | 6                   | 9                   | 12                    | #8-32 UNC   |
| 16                | 33             | 26   | 43          | 36   | 3.5        | 21   | 6                   | 9.5                 | 16                    | #8-32 UNC   |
| 20                | 35             | 26   | 45          | 36   | 4.5        | 25   | 8                   | 9.5                 | 20                    | #10-32 UNF  |
| 25                | 39             | 29   | 49          | 39   | 5          | 27   | 9.5(St=5)/10(St>5)  | 11                  | 25                    | 1/4-28 UNF  |
| 32                | 44.5           | 30.5 | 54.5        | 40.5 | 7          | 28   | 9(St≤10)/13(St>10)  | 10                  | 32                    | 5/16-24 UNF |
| 40                | 54             | 40   | 64          | 50   | 7          | 28   | 11(St≤10)/15(St>10) | 13                  | 40                    | 3/8-24 UNF  |
| 50                | 56.5           | 40.5 | 66.5        | 50.5 | 8          | 29   | 12(St≤10)/18(St>10) | 13.5                | 50                    | 1/2-20 UNF  |
| 63                | 58             | 42   | 68          | 52   | 8          | 29   | 12(St≤10)/18(St>10) | 14.5(St=5)/16(St>5) | 63                    | 1/2-20 UNF  |
| 80                | 71             | 51   | 81          | 61   | 10         | 35.5 | 14(St≤15)/20(St>15) | 16                  | 80                    | 5/18-18 UNF |
| 100               | 84.5           | 60.5 | 94.5        | 70.5 | 12         | 42.5 | 20(St=20)/26(St>20) | 21                  | 100                   | 3/4-16 UNF  |

Remark) The unmarked dimension is the same as NACQ standard type.

# Compact cylinder

## NACQ Series—Accessories

### List for ordering code of accessories

| Accessories<br>Bore size | Mounting accessories |             |             | Knuckle    |            | Sensor switch            |
|--------------------------|----------------------|-------------|-------------|------------|------------|--------------------------|
|                          | LB                   | FA/FB       | CB          | I          | Y          |                          |
| 12                       | F-NACQ12LB           | F-NACQ12FA  | F-NACQ12CB  | F-NACQ12I  | F-NACQ12Y  | CM SH<br>DM SH<br>DM SHS |
| 16                       | F-NACQ16LB           | F-NACQ16FA  | F-NACQ16CB  | F-NACQ16I  | F-NACQ16Y  |                          |
| 20                       | F-NACQ20LB           | F-NACQ20FA  | F-NACQ20CB  | F-NACQ20I  | F-NACQ20Y  |                          |
| 25                       | F-NACQ25LB           | F-NACQ25FA  | F-NACQ25CB  | F-NACQ25I  | F-NACQ25Y  | CM SH<br>DM SH<br>DM SHS |
| 32                       | F-NACQ32LB           | F-NACQ32FA  | F-NACQ32CB  | F-NACQ32I  | F-NACQ32Y  |                          |
| 40                       | F-NACQ40LB           | F-NACQ40FA  | F-NACQ40CB  | F-NACQ40I  | F-NACQ40Y  |                          |
| 50                       | F-NACQ50LB           | F-NACQ50FA  | F-NACQ50CB  | F-NACQ50I  | F-NACQ50Y  |                          |
| 63                       | F-NACQ63LB           | F-NACQ63FA  | F-NACQ63CB  |            |            |                          |
| 80                       | F-NACQ80LB           | F-NACQ80FA  | F-NACQ80CB  | F-NACQ80I  | F-NACQ80Y  |                          |
| 100                      | F-NACQ100LB          | F-NACQ100FA | F-NACQ100CB | F-NACQ100I | F-NACQ100Y |                          |

### Accessory selection

| Cylinder model \ Accessories |               |                | Mounting accessories |    |    |        | Knuckle |   | Sensor switch |          |
|------------------------------|---------------|----------------|----------------------|----|----|--------|---------|---|---------------|----------|
|                              |               |                | LB                   | FA | FB | CB [1] | I       | Y | CM SH         | DM SH(S) |
| NACQ                         | Female thread | Without magnet |                      |    |    |        | ×       | × | ×             | ×        |
|                              |               | With magnet    | ●                    | ●  | ●  | ●      |         |   | ●             | ●        |
|                              | Male thread   | Without magnet |                      |    |    |        | ●       | ● | ×             | ×        |
|                              |               | With magnet    |                      |    |    |        |         |   | ●             | ●        |
| NASQ<br>NATQ                 | Female thread | Without magnet |                      |    |    |        | ×       | × | ×             | ×        |
|                              |               | With magnet    | ●                    | ●  | ●  | ●      |         |   | ●             | ●        |
|                              | Male thread   | Without magnet |                      |    |    |        | ●       | ● | ×             | ×        |
|                              |               | With magnet    |                      |    |    |        |         |   | ●             | ●        |
| NACQD                        | Female thread | Without magnet |                      |    |    |        | ×       | × | ×             | ×        |
|                              |               | With magnet    | ●                    | ●  | ×  | ×      |         |   | ●             | ●        |
|                              | Male thread   | Without magnet |                      |    |    |        | ●       | ● | ×             | ×        |
|                              |               | With magnet    |                      |    |    |        |         |   | ●             | ●        |

[Note1] CB is attached with relevant PIN.

### Material of accessories

| Accessories<br>Bore size(mm) | Mounting accessories |    |    |    | Knuckle |   |
|------------------------------|----------------------|----|----|----|---------|---|
|                              | LB                   | FA | FB | CB | I       | Y |
| 12, 15                       | ■                    | ●  | ●  | ●  | ■       | ■ |
| 20, 25                       | ■                    | ●  | ●  | ●  | ■       | ■ |
| 32~100                       | ■                    | ●  | ●  | ■  | ■       | ■ |

●—Aluminum alloy, ■—Steel



# Compact cylinder

## NACQ Series—Accessories

### Dimensions

#### FA/FB

Φ12~Φ25

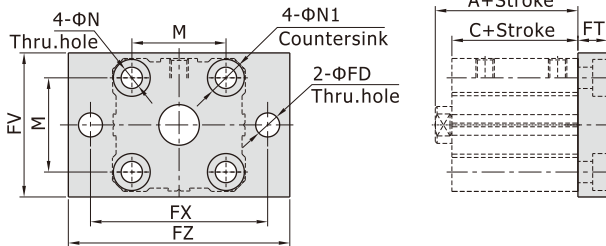

Φ32~Φ100

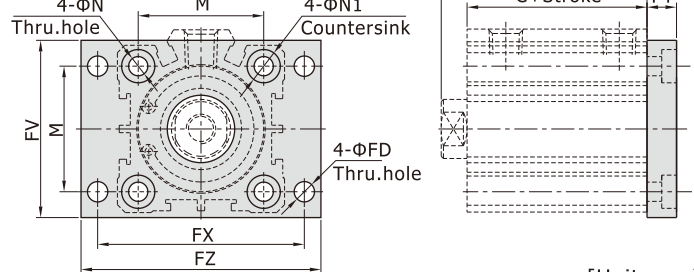

[Unit: mm]

| Item | A [Note1]      |     |      |             | C              |      |      |             | M    | N    | N1   | FD  | FT  | FV   | FX  | FZ  |
|------|----------------|-----|------|-------------|----------------|------|------|-------------|------|------|------|-----|-----|------|-----|-----|
|      | Without magnet |     |      | With magnet | Without magnet |      |      | With magnet |      |      |      |     |     |      |     |     |
|      | Stroke         | ≤50 | 55   |             | ≥60            | ≤50  | 55   |             |      |      |      |     |     |      |     |     |
| 12   | 20.5           | -   | -    | 30.5        | 17             | -    | -    | 27          | 15.5 | 4.6  | 7.5  | 4.6 | 5.5 | 25   | 45  | 55  |
| 16   | 22             | 22  | -    | 32          | 18.5           | 18.5 | -    | 28.5        | 20   | 4.6  | 7.5  | 4.6 | 5.5 | 30   | 45  | 55  |
| 20   | 24             | -   | 34   | 34          | 19.5           | -    | 29.5 | 29.5        | 25.5 | 6.8  | 10   | 6.8 | 8   | 39.5 | 48  | 60  |
| 25   | 27.5           | -   | 37.5 | 37.5        | 22.5           | -    | 32.5 | 32.5        | 28   | 6.8  | 10   | 6.8 | 8   | 42   | 52  | 64  |
| 32   | 30             | -   | 40   | 40          | 23             | -    | 33   | 33          | 34   | 6.8  | 10   | 5.5 | 8   | 48   | 56  | 65  |
| 40   | 36.5           | -   | 46.5 | 46.5        | 29.5           | -    | 39.5 | 39.5        | 40   | 6.8  | 10   | 5.5 | 8   | 54   | 62  | 72  |
| 50   | 38.5           | -   | 48.5 | 48.5        | 30.5           | -    | 40.5 | 40.5        | 50   | 8.5  | 11.5 | 6.8 | 9   | 67   | 76  | 89  |
| 63   | 44             | -   | 54   | 54          | 36             | -    | 46   | 46          | 60   | 11.6 | 16.5 | 9   | 10  | 80   | 92  | 108 |
| 80   | 53.5           | -   | 63.5 | 63.5        | 43.5           | -    | 53.5 | 53.5        | 77   | 13.2 | 19.5 | 11  | 12  | 99   | 116 | 134 |
| 100  | 65             | -   | 75   | 75          | 53             | -    | 63   | 63          | 94   | 13.2 | 19.5 | 11  | 12  | 117  | 136 | 154 |

[Note] Valve A and C in the above table are only for NACQ series.  
Please refer to relevant content for valve A and C of other series.

#### LB

Φ12~Φ25

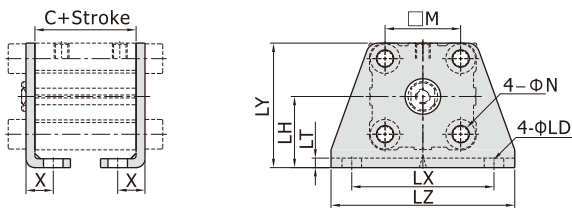

Φ32~Φ100

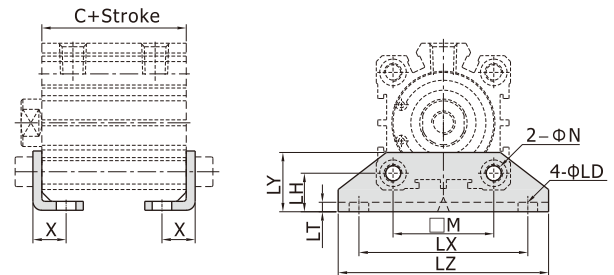

[Unit: mm]

| Bore size\Item | C [Note]       |      |      |             | M    | N    | X    | LD   | LH   | LT  | LX  | LY   | LZ  |
|----------------|----------------|------|------|-------------|------|------|------|------|------|-----|-----|------|-----|
|                | Without magnet |      |      | With magnet |      |      |      |      |      |     |     |      |     |
|                | Stroke         | ≤50  | 55   |             |      |      |      |      |      |     |     |      |     |
| 12             | 17             | -    | -    | 27          | 15.5 | 4.6  | 8    | 4.6  | 17   | 2   | 34  | 29.5 | 44  |
| 16             | 18.5           | 18.5 | -    | 28.5        | 20   | 4.6  | 8    | 4.6  | 19   | 2   | 38  | 33.5 | 48  |
| 20             | 19.5           | -    | 29.5 | 29.5        | 25.5 | 6.8  | 9.2  | 6.8  | 24   | 3   | 48  | 42   | 62  |
| 25             | 22.5           | -    | 32.5 | 32.5        | 28   | 6.8  | 10.7 | 6.8  | 26   | 3   | 52  | 46   | 66  |
| 32             | 23             | -    | 33   | 33          | 34   | 6.8  | 11.2 | 6.8  | 13   | 3   | 57  | 20   | 71  |
| 40             | 29.5           | -    | 39.5 | 39.5        | 40   | 6.8  | 11.2 | 6.8  | 13   | 3   | 64  | 20   | 78  |
| 50             | 30.5           | -    | 40.5 | 40.5        | 50   | 8.5  | 12.2 | 8.5  | 14   | 3   | 79  | 22   | 95  |
| 63             | 36             | -    | 46   | 46          | 60   | 11.6 | 13.7 | 11.6 | 16   | 3   | 95  | 26   | 113 |
| 80             | 43.5           | -    | 53.5 | 53.5        | 77   | 13.5 | 16.5 | 13.5 | 20.5 | 4.5 | 118 | 32   | 140 |
| 100            | 53             | -    | 63   | 63          | 94   | 13.5 | 23   | 13.5 | 24   | 6   | 137 | 36   | 162 |

[Note] Valve C in the above table is only for NACQ series. Please refer to relevant content for valve C of other series.

# Compact cylinder

## NACQ Series—Accessories

**CB**  $\phi 12\text{--}\phi 25$

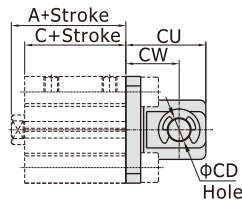
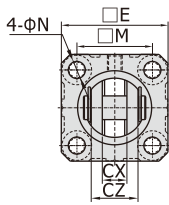

$\phi 32\text{--}\phi 100$

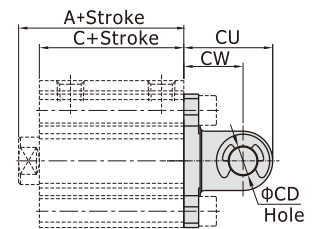
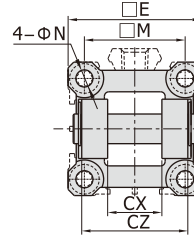

[Unit: mm]

| Item | A [Note]       |     |             |      | C              |      |             |      | E     | M    | N    | CD (inch) | CU | CW | CX   | CZ   |
|------|----------------|-----|-------------|------|----------------|------|-------------|------|-------|------|------|-----------|----|----|------|------|
|      | Without magnet |     | With magnet |      | Without magnet |      | With magnet |      |       |      |      |           |    |    |      |      |
|      | Stroke         | ≤50 | 55          | ≥60  | Stroke         | ≤50  | 55          | ≥60  |       |      |      |           |    |    |      |      |
| 12   | 20.5           | -   | -           | 30.5 | 17             | -    | -           | 27   | 25    | 15.5 | 4.6  | 3/16      | 20 | 14 | 5.3  | 9.8  |
| 16   | 22             | 22  | -           | 32   | 18.5           | 18.5 | -           | 28.5 | 29    | 20   | 4.6  | 3/16      | 21 | 15 | 6.8  | 11.8 |
| 20   | 24             | -   | 34          | 34   | 19.5           | -    | 29.5        | 29.5 | 36    | 25.5 | 6.8  | 5/16      | 27 | 18 | 8.3  | 15.8 |
| 25   | 27.5           | -   | 37.5        | 37.5 | 22.5           | -    | 32.5        | 32.5 | 40    | 28   | 6.8  | 3/8       | 30 | 20 | 10.3 | 19.8 |
| 32   | 30             | -   | 40          | 40   | 23             | -    | 33          | 33   | 45.5  | 34   | 6.8  | 3/8       | 30 | 20 | 18.3 | 35.8 |
| 40   | 36.5           | -   | 46.5        | 46.5 | 29.5           | -    | 39.5        | 39.5 | 53.5  | 40   | 6.8  | 3/8       | 32 | 22 | 18.3 | 35.8 |
| 50   | 38.5           | -   | 48.5        | 48.5 | 30.5           | -    | 40.5        | 40.5 | 64.5  | 50   | 8.5  | 1/2       | 42 | 28 | 22.3 | 43.8 |
| 63   | 44             | -   | 54          | 54   | 36             | -    | 46          | 46   | 77.5  | 60   | 11.6 | 1/2       | 44 | 30 | 22.3 | 43.8 |
| 80   | 53.5           | -   | 63.5        | 63.5 | 43.5           | -    | 53.5        | 53.5 | 98.5  | 77   | 13.2 | 3/4       | 56 | 38 | 28.3 | 55.8 |
| 100  | 65             | -   | 75          | 75   | 53             | -    | 63          | 63   | 117.5 | 94   | 13.2 | 7/8       | 67 | 45 | 32.3 | 63.8 |

[Note] Valve A and C in the above table are only for NACQ series.  
Please refer to relevant content for valve A and C of other series.

### Y Knuckle



**F-NACQ12Y**  
**F-NACQ16Y**  
**F-NACQ20Y**  
**F-NACQ25Y**

**F-NACQ32Y**  
**F-NACQ40Y**  
**F-NACQ50Y**  
**F-NACQ80Y**  
**F-NACQ100Y**

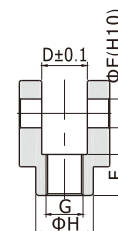
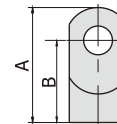
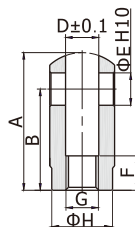
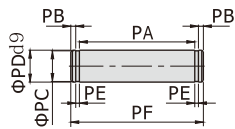
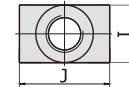

[Unit: mm]

| Type\Item  | A  | B  | D    | E (inch) | F    | G          | H  | I  | J  | PA   | PB  | PC | PD (inch) | PE  | PF   |
|------------|----|----|------|----------|------|------------|----|----|----|------|-----|----|-----------|-----|------|
| F-NACQ12Y  | 22 | 16 | 5.3  | 3/16     | 6    | #8-32UNC   | 9  | 10 | -  | 10.2 | 1.5 | 4  | 3/16      | 0.7 | 14.6 |
| F-NACQ16Y  | 28 | 21 | 6.6  | 3/16     | 11   | #8-32UNC   | 11 | 12 | -  | 12.4 | 1.5 | 4  | 3/16      | 0.7 | 16.8 |
| F-NACQ20Y  | 34 | 25 | 8.3  | 5/16     | 8.5  | #10-32UNF  | 15 | 16 | -  | 16.2 | 1.5 | 7  | 5/16      | 0.9 | 21   |
| F-NACQ25Y  | 41 | 30 | 10.3 | 3/8      | 10.5 | 1/4-28UNF  | 19 | 20 | -  | 20.2 | 2   | 8  | 3/8       | 1.1 | 26.4 |
| F-NACQ32Y  | 42 | 30 | 18.4 | 3/8      | 16   | 5/16-24UNF | 22 | 22 | 36 | 36.2 | 2   | 8  | 3/8       | 1.1 | 42.4 |
| F-NACQ40Y  | 42 | 30 | 18.4 | 3/8      | 16   | 3/8-24UNF  | 22 | 22 | 36 | 36.2 | 2   | 8  | 3/8       | 1.1 | 42.4 |
| F-NACQ50Y  | 56 | 40 | 22.4 | 1/2      | 20   | 1/2-20UNF  | 28 | 28 | 44 | 44.2 | 2   | 12 | 1/2       | 1.1 | 50.4 |
| F-NACQ80Y  | 71 | 50 | 28.4 | 3/4      | 23   | 5/8-18UNF  | 38 | 38 | 56 | 56.2 | 2   | 15 | 3/4       | 1.7 | 63.6 |
| F-NACQ100Y | 79 | 55 | 32.4 | 7/8      | 24   | 3/4-16UNF  | 44 | 44 | 64 | 64.2 | 2.5 | 19 | 7/8       | 1.7 | 72.6 |

[Unit: mm]

### I Knuckle

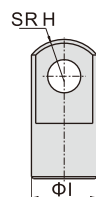
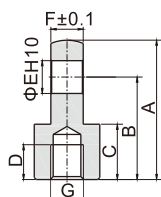

| Type\Item  | A    | B  | C    | D  | E (inch) | F    | G          | H    | I  |
|------------|------|----|------|----|----------|------|------------|------|----|
| F-NACQ12I  | 21.5 | 16 | 9    | 6  | 3/16     | 4.7  | #8-32UNC   | 6.3  | 10 |
| F-NACQ16I  | 32   | 25 | 11   | 6  | 3/16     | 6.2  | #8-32UNC   | 8.1  | 12 |
| F-NACQ20I  | 34   | 25 | 13.5 | 6  | 5/16     | 7.7  | #10-32UNF  | 10.3 | 16 |
| F-NACQ25I  | 41   | 30 | 16   | 8  | 3/8      | 9.7  | 1/4-28UNF  | 12.8 | 20 |
| F-NACQ32I  | 42   | 30 | 16   | 14 | 3/8      | 17.6 | 5/16-24UNF | 12   | 22 |
| F-NACQ40I  | 42   | 30 | 16   | 14 | 3/8      | 17.6 | 3/8-24UNF  | 12   | 22 |
| F-NACQ50I  | 56   | 40 | 20   | 18 | 1/2      | 21.6 | 1/2-20UNF  | 16   | 28 |
| F-NACQ80I  | 71   | 50 | 23   | 21 | 3/4      | 27.6 | 5/8-18UNF  | 21   | 38 |
| F-NACQ100I | 79   | 55 | 24   | 22 | 7/8      | 31.6 | 3/4-16UNF  | 24   | 44 |