

ABB IRB 6700

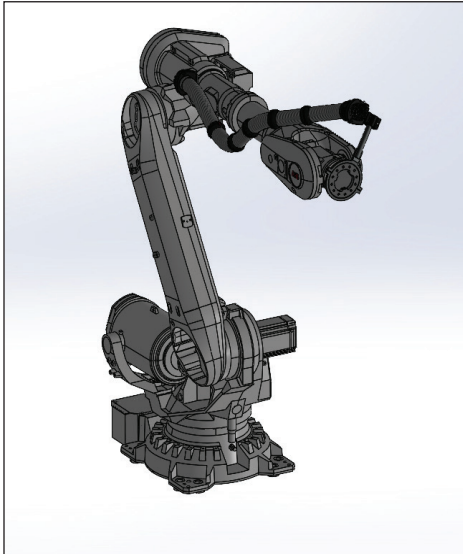

26.70.021.01 Complete robotic dresspack, Axis 3-6, without retraction system, high-flex conduit with ID 64mm

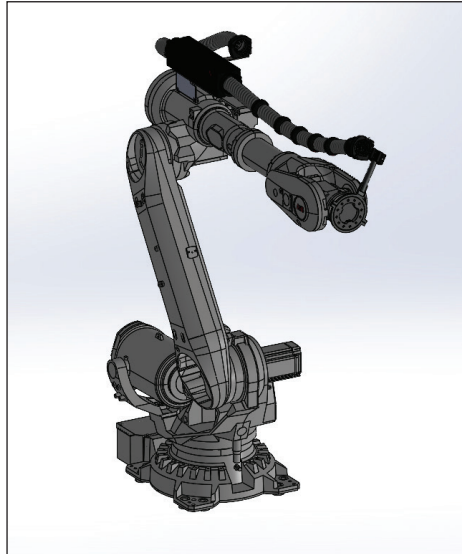

26.70.121.01 Complete robotic dresspack, Axis 3-6, TecLiner retraction system, 350mm stroke, high-flex conduit with ID 64mm

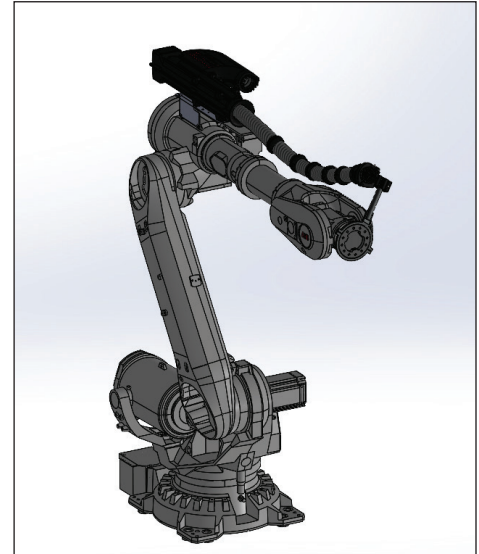

26.70.321.01 Complete robotic dresspack, Axis 3-6, TecBox retraction system, 600mm stroke, high-flex conduit with ID 64mm

Product Information

Our robotic dresspacks offer effective cable protection for the most demanding robotic applications. Specifically designed for cable routing on ABB IRB 6700 robots, our dresspacks include mounting brackets, our high-flex EWX-PAE robotic conduit, effective strain relief and optionally, a retraction system for highly dynamic applications.

Conduit Specifications



Mod. Polyamide PA 12



According to IEC EN 61386
Crush Resistance: > 1200 N



According to IEC EN 61386
Cycles: > 5000000 ~



According to IEC EN 61386
Tier: 4



According to IEC EN 61386
System tear-out strength > 100 N



-40 - 120°F
Short Periods 150°F



acc. to UL94 HB



RoHS

Part Number	Axes	Robot Model	Conduit	Retraction System	Strain Relief
26.48.021.01	A3-A6	ABB IRB 6700	M50/P48 (ID: 36.7mm)	no retraction system	finger strain relief
26.48.321.01	A3-A6	ABB IRB 6700	M50/P48 (ID: 36.7mm)	TecBox, Size 48, 400mm	finger strain relief
26.48.421.01	A3-A6	ABB IRB 6700	M50/P48 (ID: 36.7mm)	TecLiner, Size 48, 400mm	finger strain relief
26.70.021.01	A3-A6	ABB IRB 6700	70 Jumbo (ID: 64mm)	no retraction system	finger strain relief
26.70.121.01	A3-A6	ABB IRB 6700	70 Jumbo (ID: 64mm)	Tecliner, Size 70, 350mm	finger strain relief
26.70.221.01	A3-A6	ABB IRB 6700	70 Jumbo (ID: 64mm)	Tecliner, Size 70, 550mm	finger strain relief
26.70.321.01	A3-A6	ABB IRB 6700	70 Jumbo (ID: 64mm)	Tecbox, Size 70, 600mm	finger strain relief

**Custom non-populated or fully populated dresspacks for any type of industrial robot along all axes can also be requested.*