

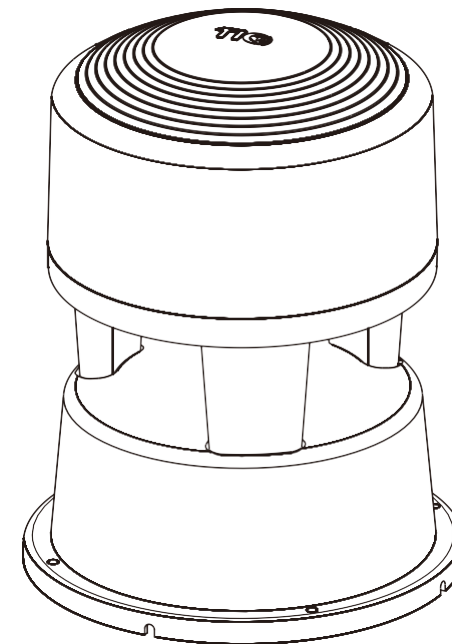

B series

Outdoor Omnidirectional
In-Ground/Surface-Mount Speaker

Instruction Manual



[page intentionally left blank]

Before you begin

A passive outdoor loudspeaker system is one of the best audio entertainment investments you can make for both residential and commercial installations. Investing the time and labor to install a wired speaker system will provide the safest and most dependable sound solution that can be easily upgraded and customized over time.

Before connecting the speakers, please take the time to design and review the overall system, making sure the speakers are well-situated to provide an even coverage with adequate sound level. Depending on the specific model, the speaker may or may not include a wire tail. You will likely need to purchase additional speaker wires to connect the entire sound system. The longer the distance covered, the higher gauge of speaker wires should be used to maximize audio performance.

When selecting and connecting an amplifier to a passive loudspeaker, it is important to understand the relationship and impact of the impedance load and power wattage between the amplifier and loudspeaker. Caution must be used to ensure the impedance load of the loudspeaker and system is compatible with the selected amplifier's operable range, especially when loudspeakers are wired in parallel series, or a combination of the two. Incorrect impedance matching may cause irreparable damage to your audio equipment.

When considering the power of your amplifier, most audio professionals and audiophile will recommend an amplifier with an output power above the loudspeaker's power handling rating. This is the ideal set up to maximize audio performance as the extra power will ensure delivery of sufficient power during short periods of audio peaks along with fuller dynamic range and effortless loud volume output. However, the ability to deliver extra power may cause potential damage to the loudspeaker, especially when playing loudly in a sustained period. Caution and restraint must be used to ensure longevity of the loudspeaker under the ideal set up. If longevity and safe operation is more important than optimal audio performance, you should select an amplifier with an RMS power rating at or slightly below the loudspeaker's rating. Please consult a professional installer if you are unsure about impedance and power level matching. If you need help or have further question, please contact us at www.ticcorp.com.

Wiring Diagram

Choose the appropriate wiring option depending on your model and overall system design.

Simple 8Ω installation

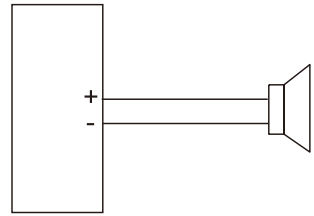

mono or bridged mode

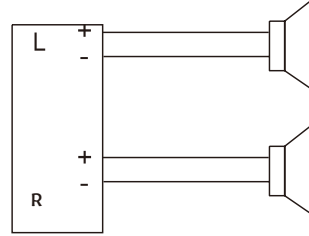

stereo mode

** Colorized version of wiring diagrams is available on our website (www.ticcorp.com). In typical installations, positive terminals are connected to red wires and negative terminals are connected to black wires.*

Four 8Ω speakers 2-channel installation

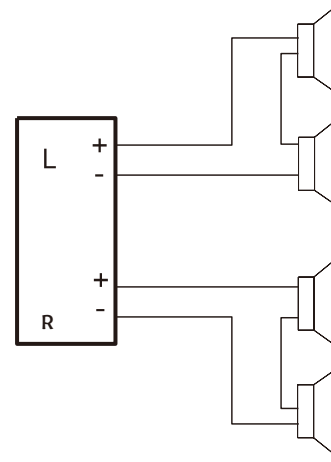

series wiring(16Ω/channel)

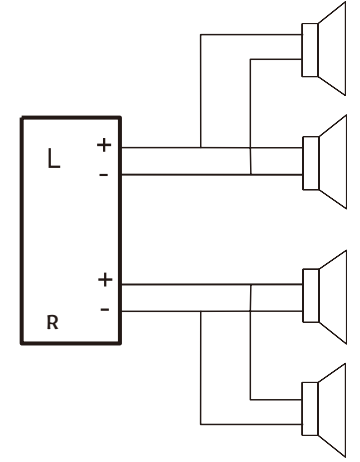

parallel wiring(4Ω/channel)

Eight 8Ω speakers 2-channel installation

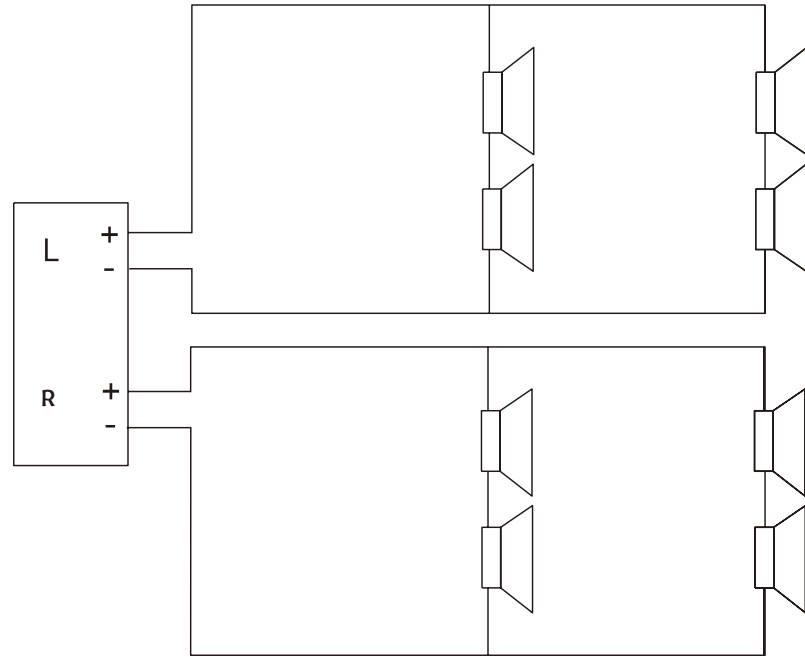

series-parallel wiring(8Ω/channel)

Subwoofer installation

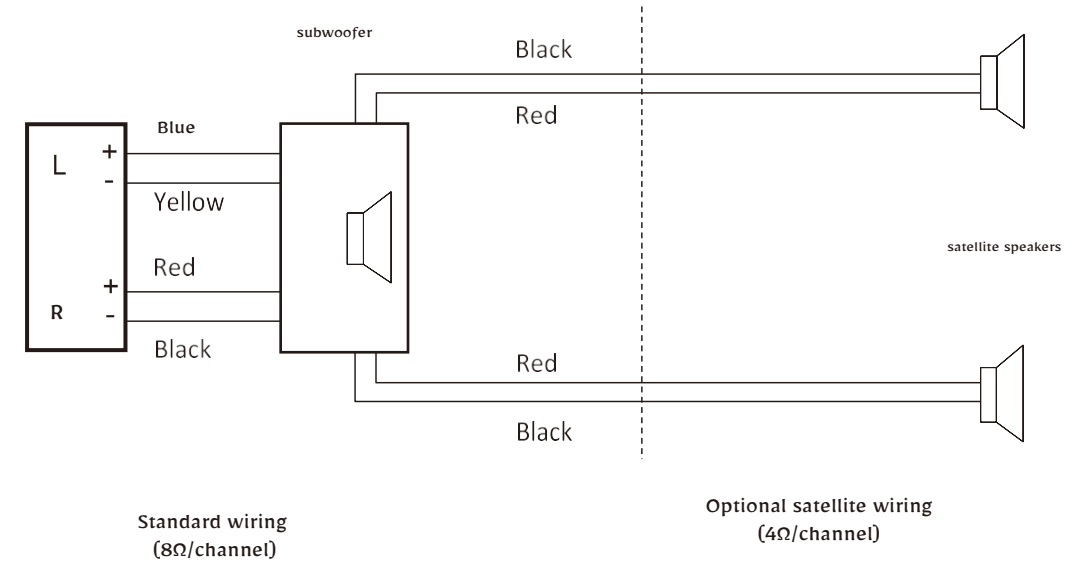

Installation/Maintenance Note

- The B series speaker can be installed in-ground or surface-mounted. In-ground installation is generally optimal since burying the speaker in-ground will enhance its resonance, providing a fuller audio experience. When mounted on a surface, please ensure the wiring is safely secured and does not become a tripping hazard. The optimal burial depth is 1 inch exposure from ground level for the bottom section.
- For in-ground installation, only burial-grade insulated speaker wires should be used. Conduit can be used alternatively in conjunction with standard speaker wires. Wire and conduit should be buried 4-6" below ground.
- For connecting/extending speaker wires, we highly recommend using waterproof wire connector (ie. SPC-CN1).
- Alternately, silicon can be applied to the opening of standard wire nut to provide water protection. The B series is designed to be water-resistant, not waterproof. It is not designed to be protected against total water submersion, such as heavy flooding. With the raised downward facing profile, it's unlikely for the speaker to be submerged in water under normal rain and snow conditions. Please use caution and consider relocating the speaker when there is chance for heavy flood or snowfall.
- The system should be fully tested above surface before speakers and wires are buried.
- If sound is muddled or multiple speakers are not in sync, please check to ensure wire polarity is correct.
- To clean speaker, you can rinse with fresh water from directly above the speaker and wipe with a cloth. If need be, use mild detergent to remove dirt.

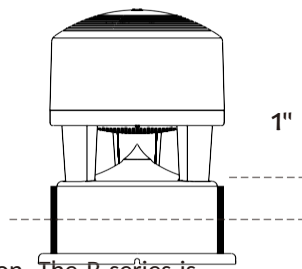

70v Operation:

B13 speaker can operate in both standard 8Ω mode and 70v mode. The 70v option, which is a constant voltage system, offers ease of installation for audio system with large quantities of loudspeakers and minimize the concern for power loss over long distance wire runs. However, there are also disadvantages to 70v system such as limitations to mono output and degradation of signal, especially in low frequencies, though often not noticeable except by discerning ears. 70v is often the preferred choice in large installations, such as many commercial projects, for both PA systems and background music systems. If you are unsure about 70v, please contact TIC or a trusted AV professional for consultation.

If you are using B13 with a regular amplifier, please set dial to 8Ω and connect as normal.

To operate in 70v mode, you must utilize a 70v amplifier. Simply set the dial to any of the wattage setting and connect the speaker to a 70v amplifier that has power output at least 20% greater than the summation of all speaker wattage settings within the sound system. The 20% headroom ensures optimal performance and longevity to both amplifier and speakers. The correct wattage setting will depend on your volume and sound sculpting requirement and the power output of your amplifier.

Specification

	<u>B03</u>	<u>B13</u>	<u>B50</u>
Type	Single Coaxial	Single Coaxial	Subwoofer
Driver Size	8" woofer 2" tweeter	8" woofer 2" tweeter	8" subwoofer
Power Handling (RMS/Peak)	100W/200W	100W/200W (8Ω mode)	125W/250W
Impedance	8Ω	8Ω/70v	8Ω (standard) 4Ω (with satellites)

TIC Audio Inc. All rights reserved. The TIC logo is a trademark of TIC Audio Inc, registered in the United States. Features, specifications, and appearance are subject to change without notice.

Please consult audio professionals if you have any question regarding sound system design and installation.

For more information, please visit our website: www.ticcorp.com.