

XPJ-1641SR / XPJ-1682SR

Startup Guide

Unpacking and Initial Setup

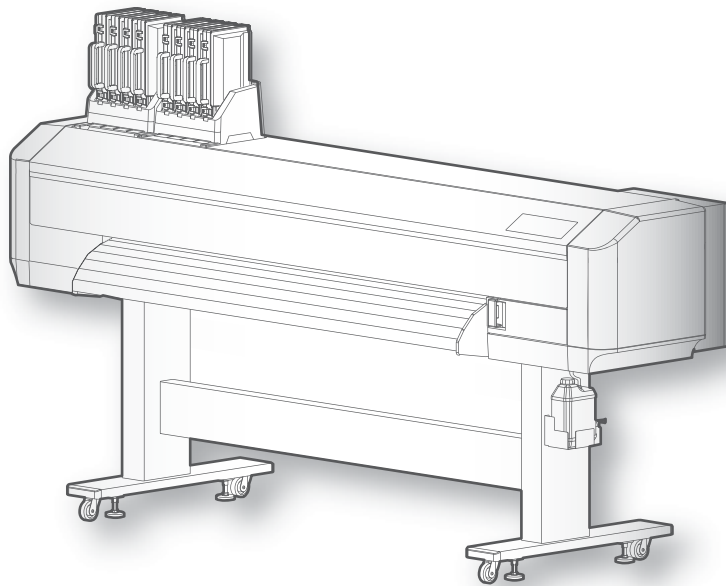

Site Preparation	2
Unpacking	4
Assembling	8
Connecting Power and Network	13
Printer Initial Setup	15
Test printing	28
Installing MUTOH Status Monitor	38
Viewing Operation Manual	39
Safety Precautions	40

-
- Unauthorized copying or duplication of the whole or part of the contents of this Guide is prohibited.
 - Every care has been taken in writing the contents of this Guide, but please contact MUTOH or the dealer you purchased the product from if you find any unclear, erroneous or otherwise unsatisfactory content in the Guide.
 - Please be aware that MUTOH will not be liable in any way for failures or accidents that result from handling or operating the printer according to any procedures other than those set forth in this Guide.
 - Company names and product names that appear in this Guide are registered trademarks of the respective companies.

Site Preparation

Choose the location which satisfies the requirements below.

Installation Location Requirements

- The floor must be level.
- Avoid vibration from the neighboring devices.
- Low humidity and free from dust.
- Less chance of temperature and humidity changes.
- Avoid direct sunlight.
- Avoid water.
- Avoid direct air onto the printer.
- Low levels of electromagnetic waves.

CAUTION

- **Choose the floor that can safely support the weight of this product.**

The total weight of printer and stand is 280 kg.

If the floor does not have sufficient load capacity, it can lead to injury from a fall.

- **This equipment is not suitable for use in locations where children are likely to be present.**
- **Keep the work area well ventilated while operating.**

Ink odor may cause health problem such as headache, dizziness, or dull. If you experience these symptoms, stop printer operation and move to fresh air. Seek medical attention if vomit persists.

The following space is required for installation.

Minimum Space Requirements

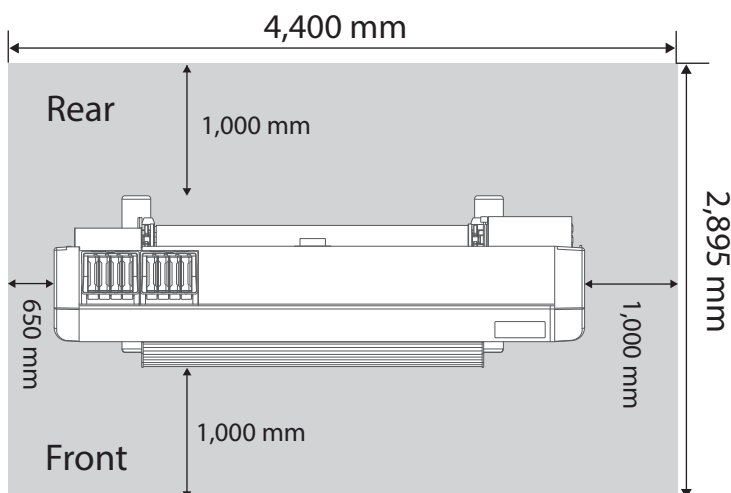

Printer Size

Width x Depth: 2,750 mm x 895 mm

Height : 1,611 mm *1

*1 When installing ink bag cases.

The room height should be at least 1,760 mm.

The installation site must meet the power specification and environmental requirements below.

Power Specification

- Printer:

Input voltage: AC 100V to 120V±10% / AC 200V to 240V±10%

Input frequency: 50 / 60Hz ±1Hz

Input load current: 9 A (AC 100V - 120V), 6 A (AC 200V - 240V)

- Heater:

Input voltage: AC 100V to 120V±10% / AC 200V to 240V±10%

Input frequency: 50 / 60Hz ±1Hz

Input load current: 10 A (AC 100V - 120V), 5 A (AC 200V - 240V)

Important!

This product has two power cords for printer and heater and requires the total load current as follows:

- XPJ-1641SR/XPJ-1682SR: 19 A (AC 100V - 120V), 11 A (AC 200V - 240V)

If the total current exceeds the maximum capacity of the wall outlet with two or more jacks, connect one of the two power plugs into another wall outlet.

Environmental Requirements

- Operating condition:

Temperature: 20°C to 32°C, Humidity: 40% to 60%, non condensing

- Printing Condition:

Temperature: 22°C to 30°C, Humidity: 40% to 60%, non condensing

Change rate

Temperature: No more than 2 °C per 1 hour

Humidity: No more than 5% per 1 hour

- Printer Storage Condition:

Without ink filled: Up to 6 months (Temperature: -20°C to 60°C, Humidity: 20% to 80%, non condensing)

With ink filled: Up to 1 week (Temperature: -10°C to 40°C, Humidity: 20% to 80%, non condensing)

Storage up to 4 days maximum when stored between 32 °C to 40 °C.

- Ink Storage Condition:

Black / Cyan / Magenta / Yellow/ Light Cyan / Light Magenta / Light Black (1,000 ml each)

Temperature: -20°C to 40°C, Humidity: 5% to 85%, non condensing

Cleaning bag (300 ml)

Temperature: 5°C to 40°C, Storage up to 6 months maximum when stored between -5 °C to 5 °C or 30 °C to 40 °C.

Humidity: 80% or less non condensing

Unpacking

Before unpacking, read the instructions below and prepare the necessary items.

Unpacking Preparation

- Minimum 4 people are required for unpacking, assembling and installation.
- The items listed below are required for installation and initial setup.

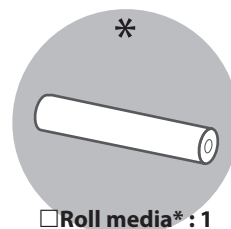
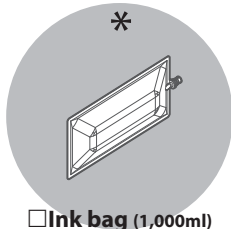
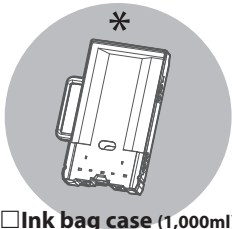
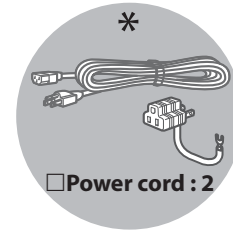
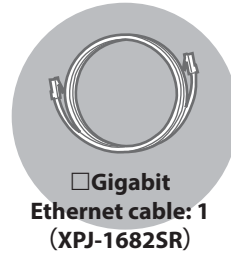
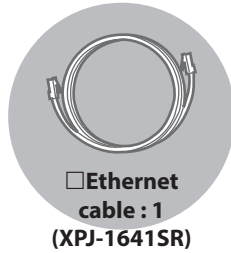
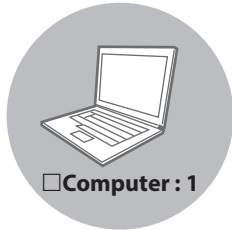

* Usable size
Media core diameter: 2 inches or 3 inches
Outer diameter: Φ 150 mm or less
Width: 1,000 mm to 1,625 mm
Weight: 30 kg or less



WARNING

Use the designated power cords.

Failure to do so may result in electric shock or fire.



Important!

Your computer must meet the following minimum requirements:

- **OS:** Windows 10 (64bit), Windows 8/8.1 (64bit), Windows 7 (64bit)
- **CPU:** Intel (R) Core (TM) i5 / i7
- **Memory:** 8GB minimum
- **Network:**
XPJ-1641SR: Use a network port that supports Ethernet port, Ethernet cable (Category 5 or later)
XPJ-1682SR: Use a network port that supports Gigabit Ethernet port, Gigabit Ethernet cable (Category 6 or later)



Note

Items marked with an asterisk (*) above are accessories or supplies.

Unpack the product.

Unpacking the printer

CAUTION

- **Minimum four people are required for unpacking and moving this product.**
- **When taking out the product from the packing box, remove the plastic sheet wrapped around the product, then take out the product. Failure to do so may cause slip and damage to the product.**
- **Keep the product level while moving it.**

[1] Open the packing box and take out the items listed below.

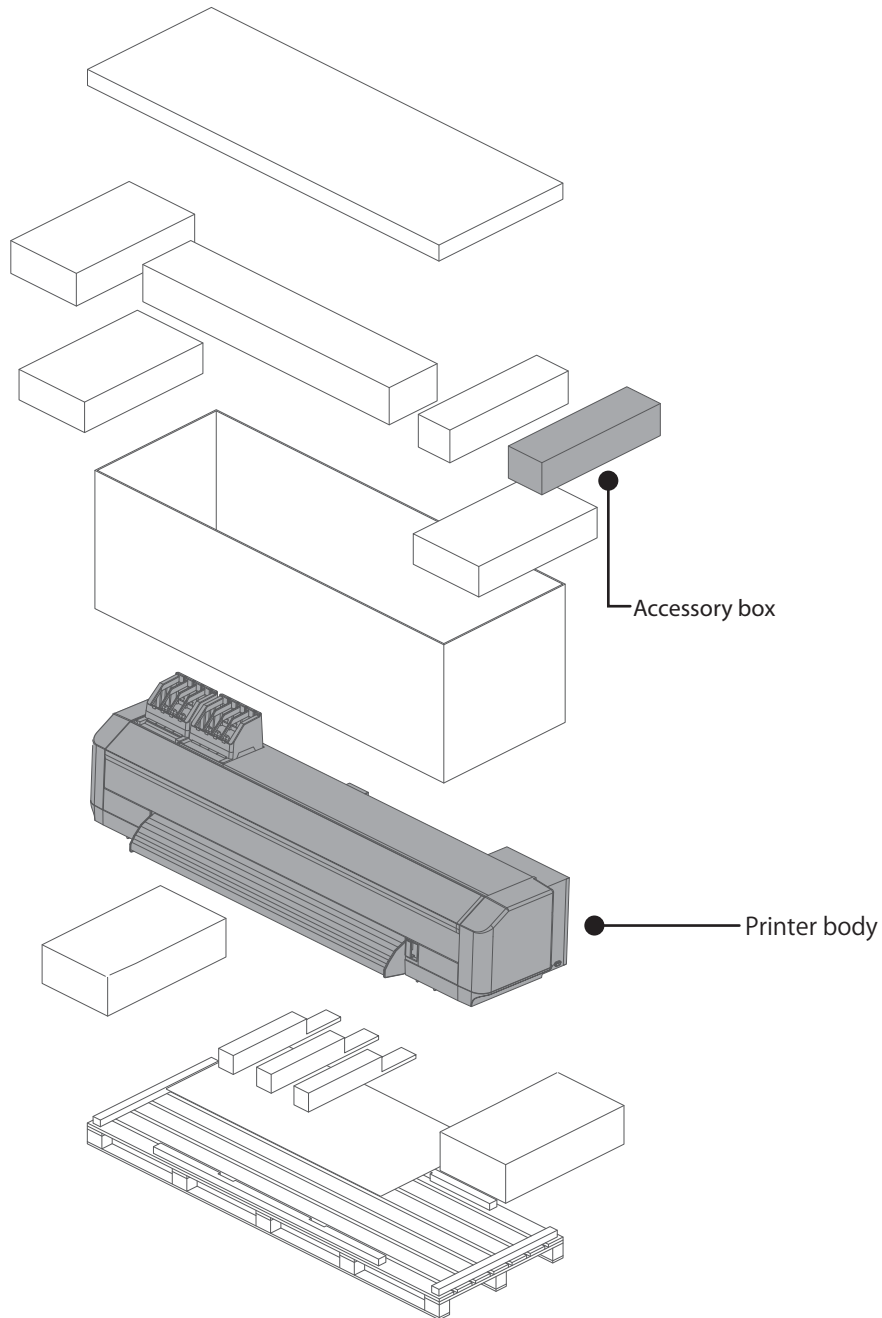

[2] Check that the following items are included.

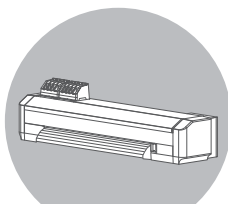

Printer : 1



Startup Guide : Japanese/English (each)

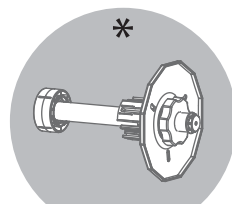

Media flange : 2



Waste ink tank : 1

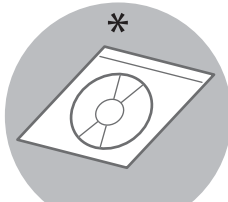

Operation Manual CD : 1

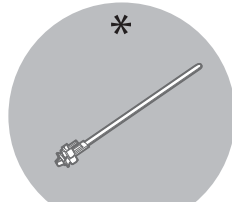

Cable tie : 1

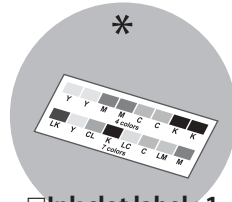

Ink slot label : 1 (XPJ-1682SR)

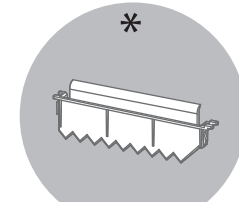

Cleaning wiper : 2

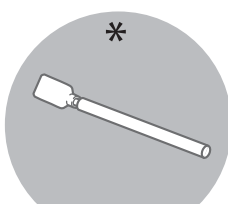

Cleaning stick : 10



Paper towel : 5

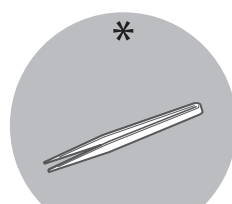

Tweezers : 1

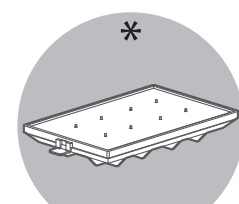

Flushing box sponge : 5



Note

Items marked with an asterisk (*) above are in the accessory box.

Unpacking Stand

[1] Open the packing box and take out the items listed below.

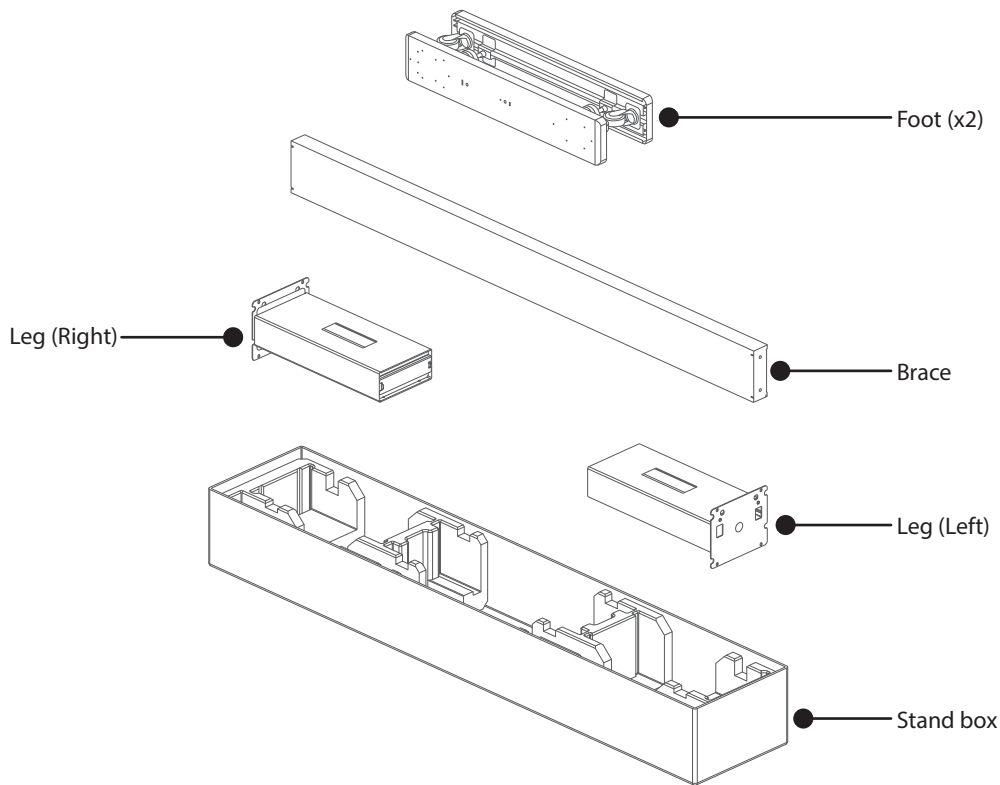

[2] Check that the following items are included.

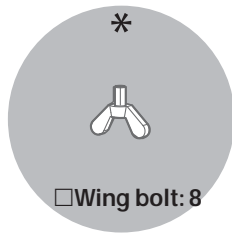
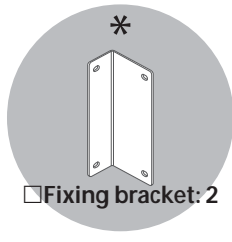
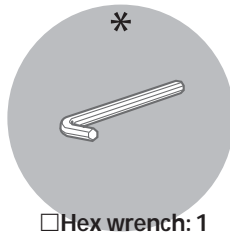
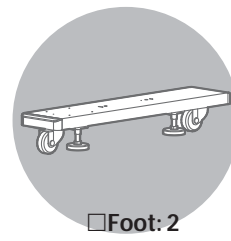
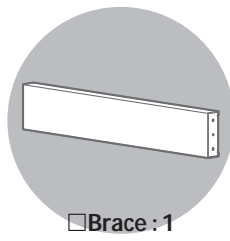
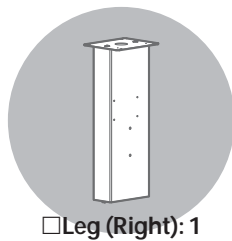
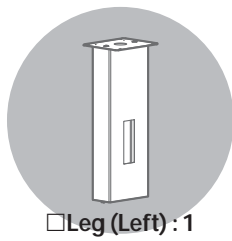

Note

Items marked with an asterisk (*) above are in the accessory box.

Assembling

Follow the steps below to assemble the stand.

Assembling Stand



Minimum two people are required for assembling the stand.

- [1] Attach the left leg and right leg to the brace.
- Face the groove on the brace toward the rear side of the printer and attach it to both legs.
 - The leg with two warning labels attached is the right leg.
 - Put the spring washers on the hex head screws (4 each), then tighten the screws.

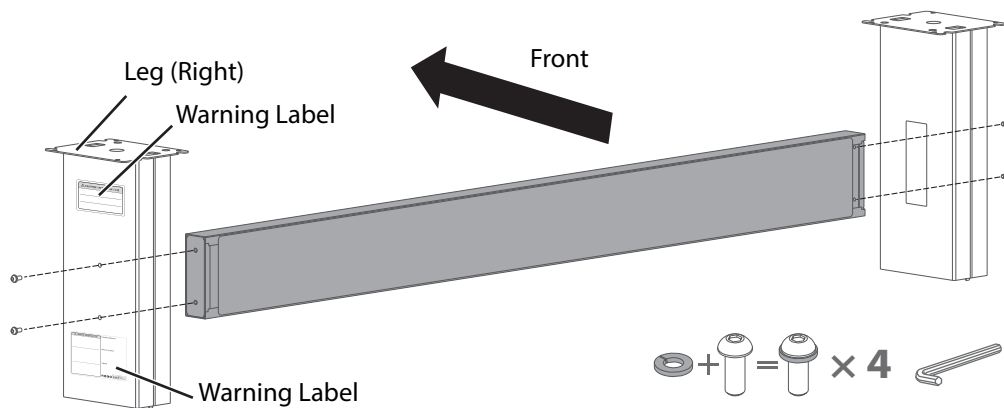

- [2] Attach the foot to the leg.
- Face the screw holes on the foot toward the front side of the printer and attach it to the leg.
 - Put the spring washers on the hex head screws (4 each), then tighten the screws.
 - Use the round head screws (x8) to fix the fixing brackets (x2) on the brace and both legs.

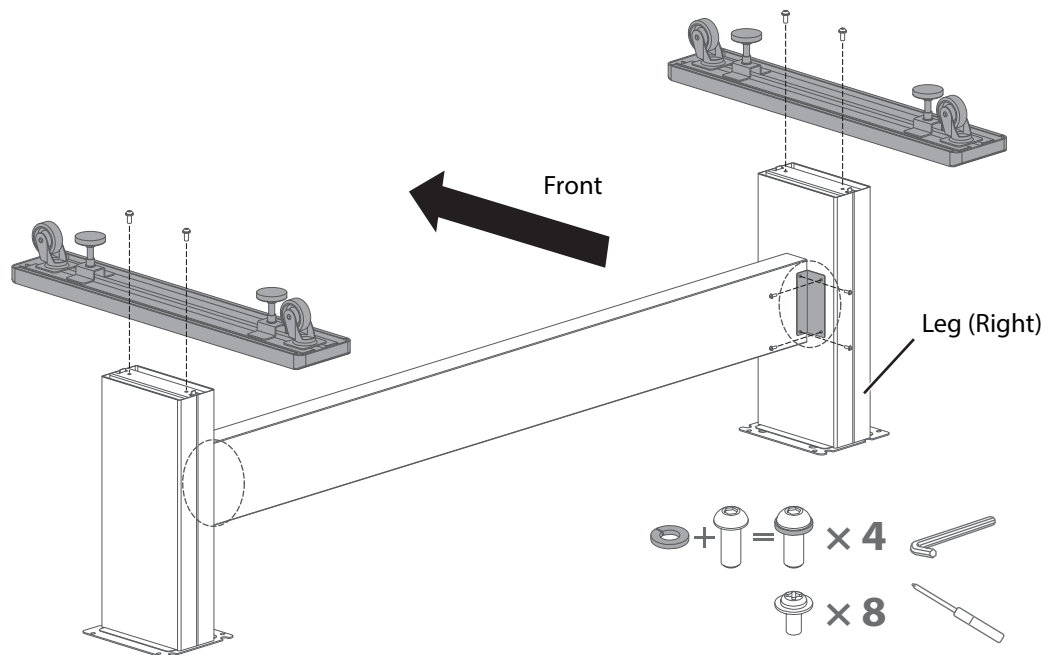

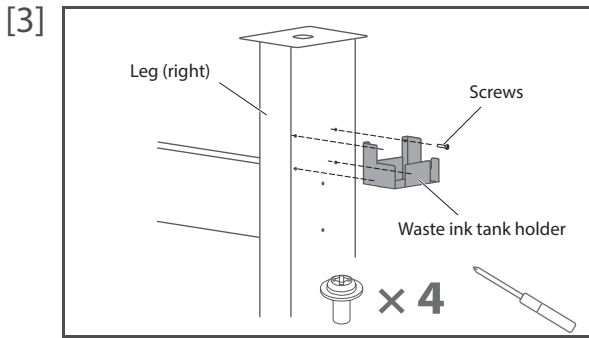

Use the round head screws (x4) to attach the waste ink tank holder to the right leg.

[4] Shake the stand to make sure that each part is firmly attached.

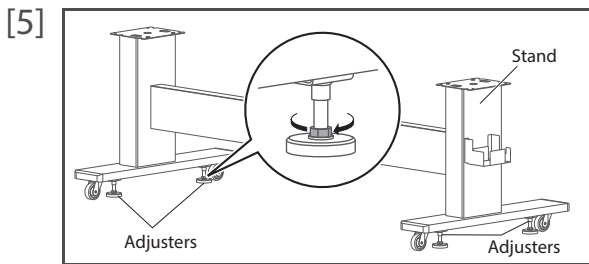

Turn the leveling adjusters (x4) as shown on the left until the stand does not move.

Follow the steps below to attach the printer to the stand.

Attaching Printer

CAUTION

- **Minimum four people are required for this process.**
- **When taking out the product from the packing box, remove the plastic sheet wrapped around the product, then take out the product. Failure to do so may cause slip and damage to the product.**
- **Keep the product level while attaching.**

[1] Lift the printer with at least four people and mount it on the stand.

- Use two lifting bars to insert into the guide holes at the bottom left and right of the printer, and lift up on the stand.

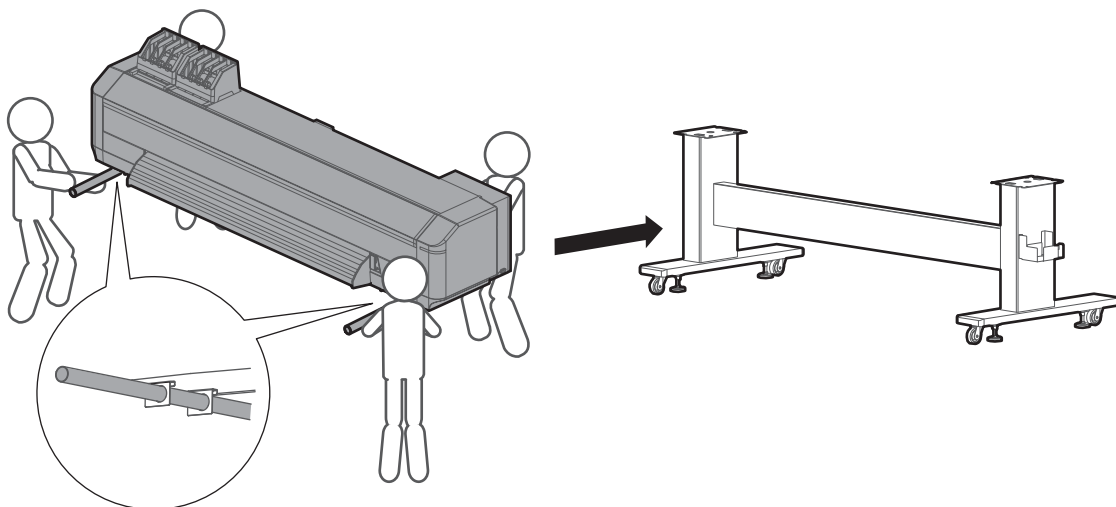

(If you do not have lifting bars) Lift the printer with at least four people and mount it on the stand.

- Use the handholds at the front bottom of the printer.

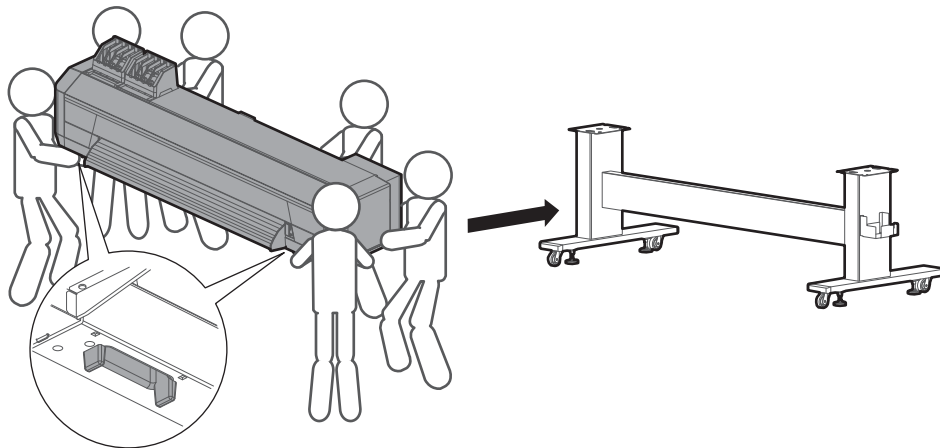

- [2] Use the wing bolts (x8) and attach the printer to the stand.

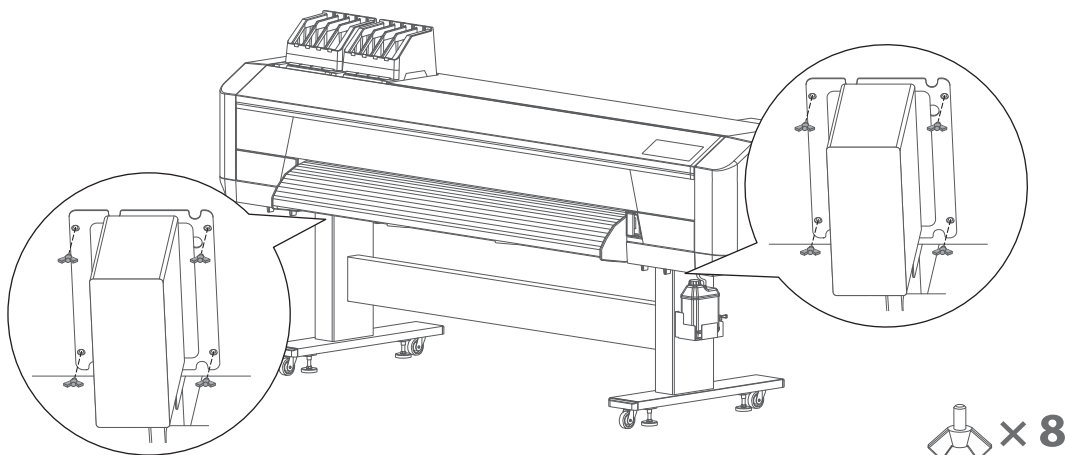

Remove packing materials from the product.

Removing Packing Materials

- [1] Remove the packing tapes from all the covers.
- [2] (XPJ-1682SR only) Remove two screws each (M3 x 45) to remove two front cover locks.

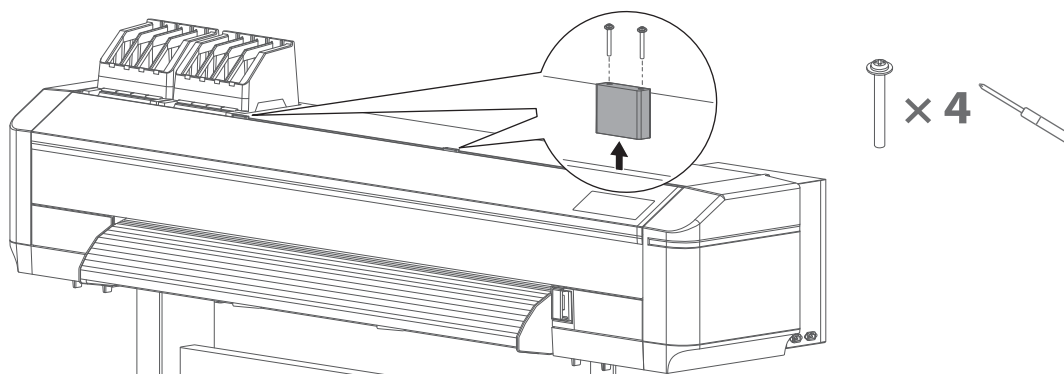

Important!

Make sure to remove two front cover locks before opening the front cover. Otherwise it will cause damage to the cover.

[3] (XPJ-1682SR only)

①: Open the front cover and remove two screws each (M4x8) to remove two front cover lock plates.

②: Use the screws just removed to fasten to the mounting holes on the printer.

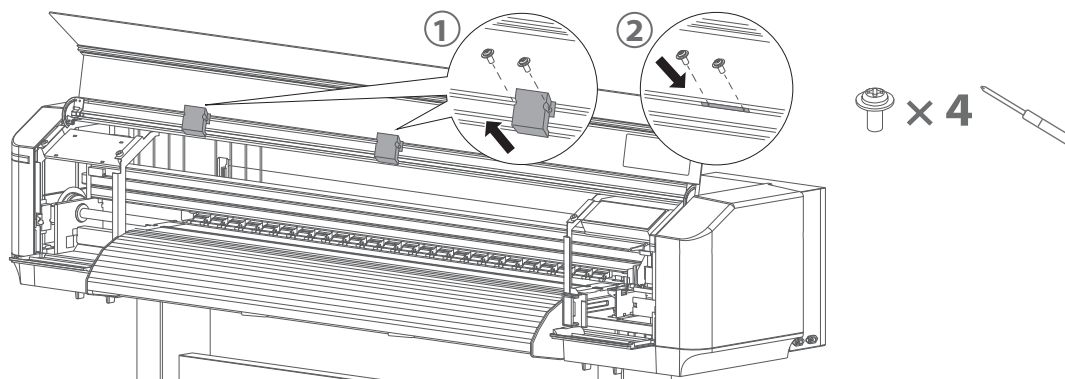

[4] Open the front cover. Remove the wing bolt to remove the shipping bracket from the carriage.

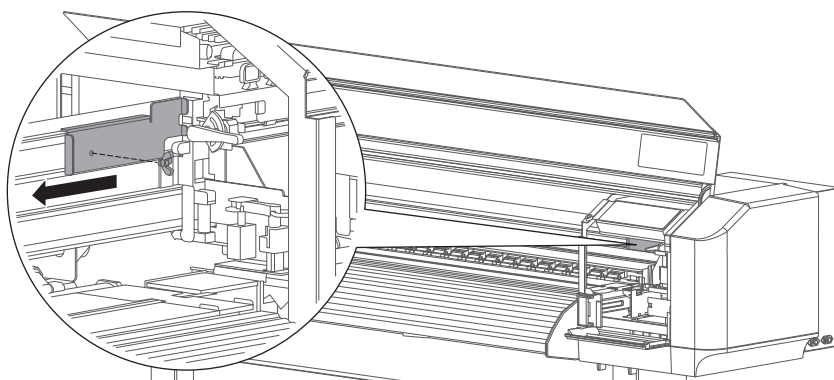

[5] (XPJ1682SR only) Remove the tape, then remove the packing material from the bottom of the carriage.

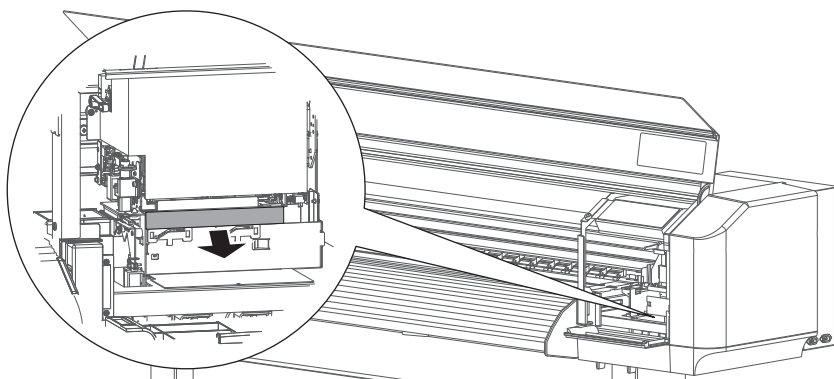

[6] Remove the tape, and move the edge holders to the left and the right edge.

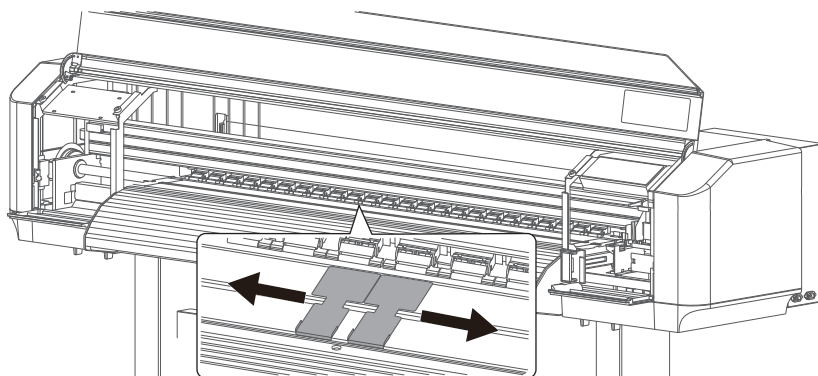

Attach the waste ink tank to the printer.

Attaching Waste Ink Tank

- [1] Place the waste ink tank on the waste ink tank holder.
 - [2] Use the waste ink tank tube to connect the waste ink tank to the printer.
 - Cover up the connector of the tank with the tube.
- Connect the waste ink sensor cable to the waste ink sensor connector.

 **Important!**

Check that the connector of the tank is fully covered with the tube. Failure to do so may cause ink spillage.

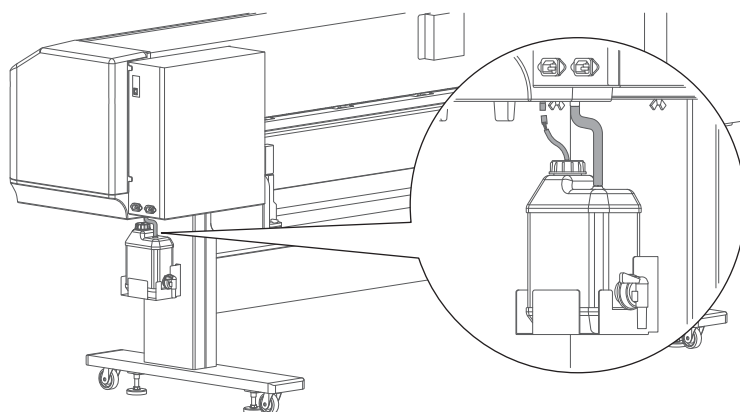

Connecting Power and Network

Follow the steps below to connect the power cords and Ethernet cable.

Connect Power Cords and Ethernet Cable

- [1] Check that the front cover is closed.

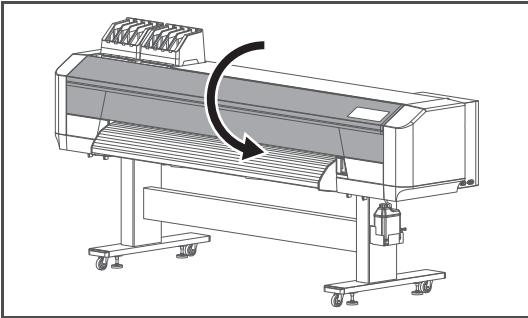

- [2] Connect two power cords and a Ethernet cable to the printer.

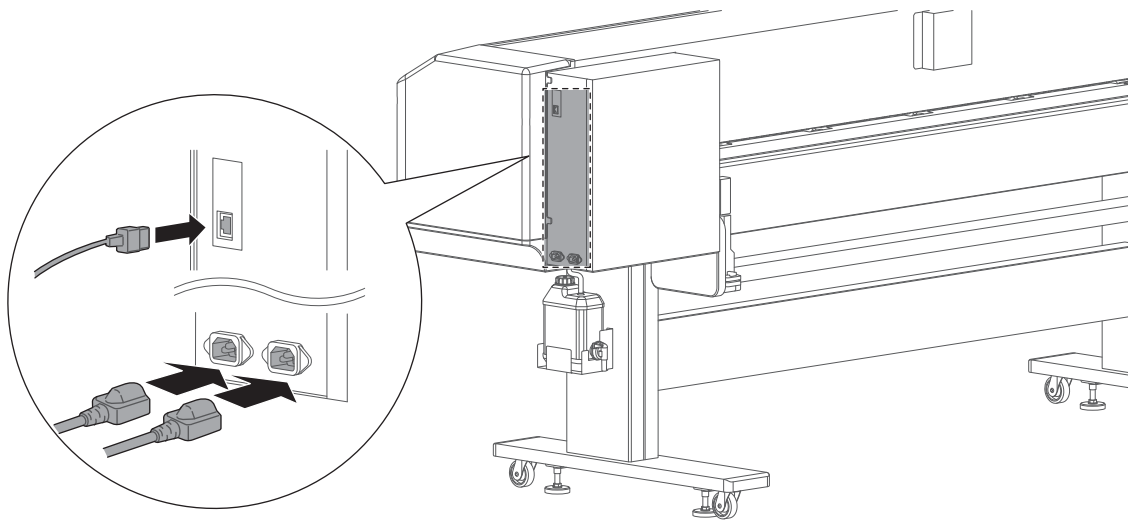

WARNING

Make sure to plug two power cords into the wall outlets with the same voltage.
Failure to do so may cause damage to the electrical circuit.

[3] Insert the tip of the cable tie into the hole on the printer to attach it.

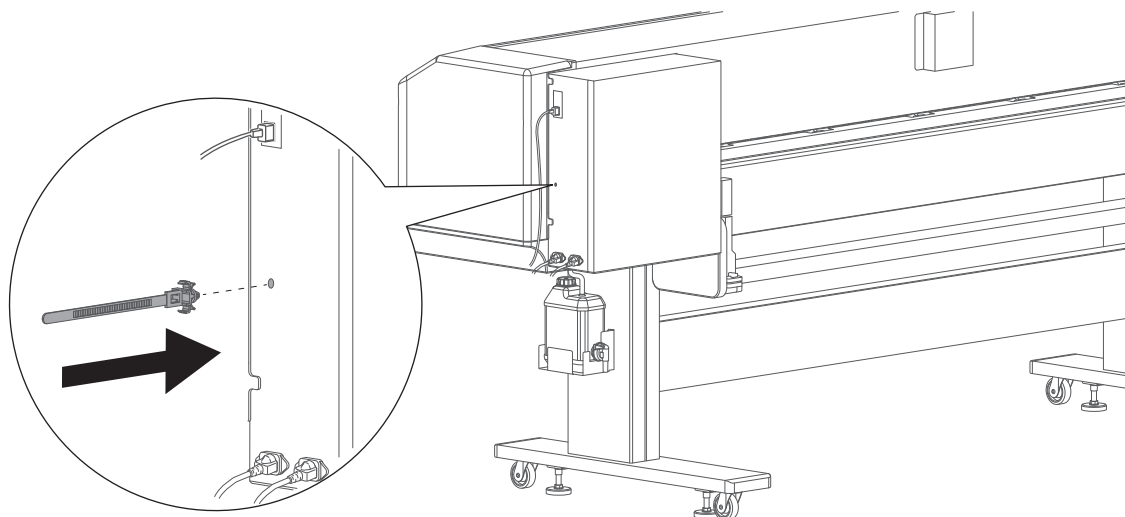

[4] Use the cable tie to secure the Ethernet cable to the printer.

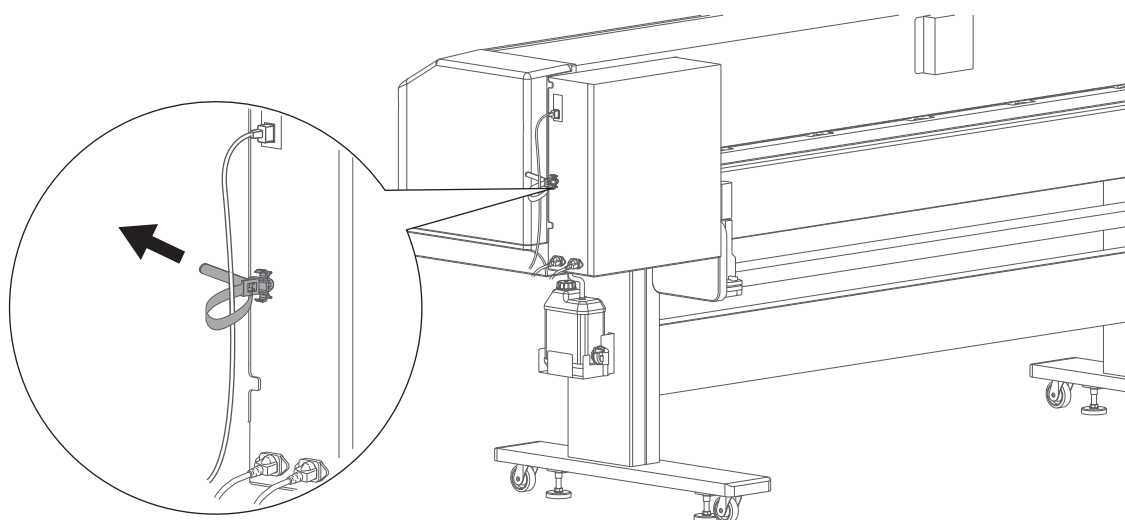

[5] Plug two power cords into the wall outlets respectively.

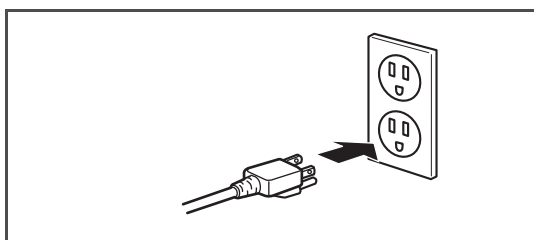

Important!

To plug into one wall outlet with two or more jacks, check that the total current does not exceed the maximum capacity of the wall outlet. If exceeded, connect one of the two power plugs into another wall outlet.

Important!

Electric shock hazard.

This printer has two power cords. To unplug from the wall outlet, make sure to unplug both of them.



Printer Initial Setup

Here is how to get started with your printer.

Note

Use one of the following methods to run the initial setup.

- Follow the instructions in the Startup Wizard to set up the settings via computer.
👉 ["Initial Setup Flow via Startup Wizard" P. 15](#)
- Follow the instructions in this Guide to set up the settings from operation panel.
👉 ["Initial Setup Flow via Operation Panel" P. 17](#)

Initial Setup Flow via Startup Wizard

Install MUTOH Status Monitor to your computer

Install MUTOH Status Monitor (MSM).

Activate the printer

Enter the activation code.

Configure the initial settings

Enter the IP address and configure the initial setup on MSM.

Perform initial ink charging

Install ink bags into the printer and perform ink charging.

Load a roll media for test printing.

Load a roll media for the nozzle check printing.

Run a nozzle check and perform cleaning

Run a nozzle check print and perform cleaning until all nozzles are clear.

Initial setup is now complete!

Site Preparation

Unpacking

Assembling

Connecting Power
and Network

Printer Initial
Setup

Test printing

Installing MSM

Viewing
Operation Manual

Safety
Precautions

Powering on - Installing MSM

To run the initial setup through the Startup Wizard on MSM, install MSM on your computer. Then follow the Startup Wizard to run the initial setup.

Note

- **Make sure to install MSM stored in the supplied CD.**

[1] Check that the front cover is closed.

[2]

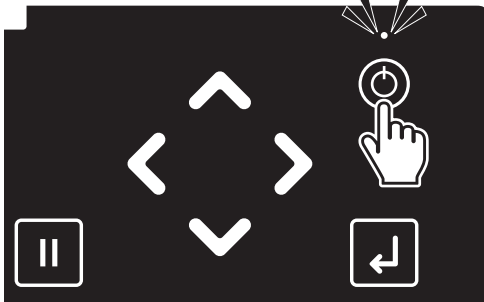

Long press the Power button on the front panel.

- The Power LED (above the Power button) lights up.
- The printer will start mechanical initialization.

Note

Once the Power LED lights up, release the Power button.

[3] Use the Ethernet cable to connect the printer to your computer.

[4]

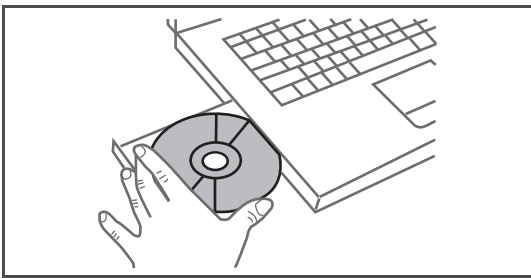

Insert the supplied CD into the CD-ROM drive.

Note

- The Startup Wizard will start up automatically.
- If the Startup wizard does not automatically start, right click the icon of CD-ROM drive, open the contents of CD with [Open], and double click MpTotalInst.exe.

[5] Follow the instructions on the Startup Wizard to setup.

- When setup is complete, carry out test printing.

 ["Test printing" P. 28](#)

Note

- Please keep the supplied CD at hand. You will need it for reinstallation.
- If lost, you can download from MUTOH Club (user registration is required).
(MUTOH Club) <https://club.mutoh.co.jp/mutoh/guser>

Initial Setup Flow via Operation Panel

Configure the initial settings

Choose and configure the language, unit of length, temperature, and network setting from the front panel.

Activate the printer

Enter the activation code from the front panel.

Perform initial ink charging

Install ink bags into the printer and perform ink charging.

Load a roll media for test printing.

Load a roll media for the nozzle check printing.

Run a nozzle check and perform cleaning

Run a nozzle check print and perform cleaning until all nozzles are clear.

Connect the printer to your computer

Enter the IP address from the touch panel.
Install MUTOH Status Monitor (MSM) and configure the initial setup on MSM.

Initial setup is now complete!

Front panel

The printer has a touch-screen panel located on the front right of the printer. The active keys are lit up on the panel for guidance.

- Tap: Lightly touch the key with your finger, then immediately release.
- Long-touch: Keep touching the key.

Site Preparation

Unpacking

Assembling

Connecting Power
and Network

Printer Initial
Setup

Test printing

Installing MSM

Viewing
Operation Manual

Safety
Precautions

Power on the printer and configure the initial settings on the front panel.

Step 1 Powering on - Initial settings on the front panel

[1] Check that the front cover is closed.

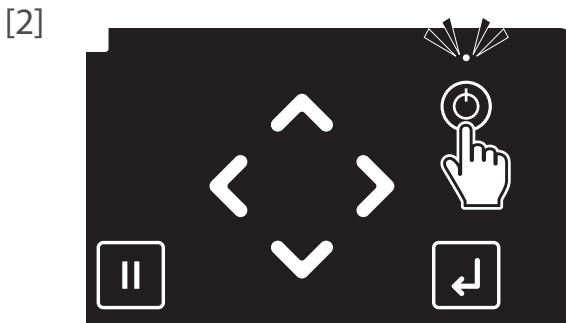

Long press the Power button on the front panel.

- The Power LED (above the Power button) lights up.
- The printer will start mechanical initialization.

Note

Once the Power LED lights up, release the Power button.



Use  to select the language.

Tap [Enter].







Tap [Enter].

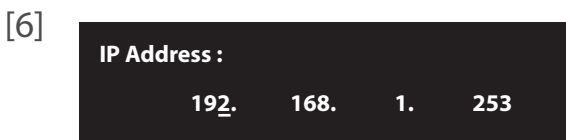

Tap [Enter].



Sets the IP address of the printer.

-  key: Increase the number.
-  key: Decrease the number.
-  key: Move the cursor to the previous digit.
-  key: Move the cursor to the next digit.

Tap [Enter] after entering each digit.



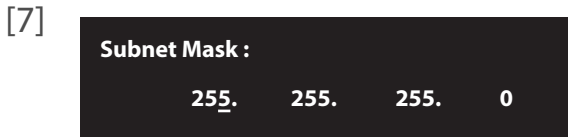

Sets the subnet mask of the printer.

- key: Increase the number.
- key: Decrease the number.
- key: Move the cursor to the previous digit.
- key: Move the cursor to the next digit.

Tap [Enter] after entering each digit.

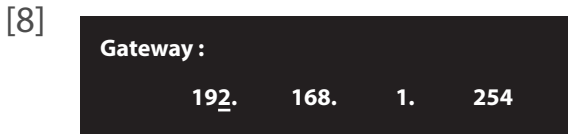
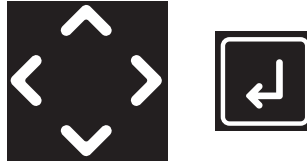

Sets the gateway.

- key: Increase the number.
- key: Decrease the number.
- key: Move the cursor to the previous digit.
- key: Move the cursor to the next digit.

Tap [Enter] after entering each digit.



The printer will start mechanical initialization.

Follow the steps below to perform activation.

Step 2 Activation

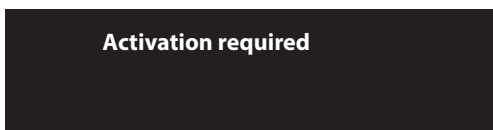

When the message on the left appears, use one of the following methods to activate the printer.

- ["Activation through the front panel" P. 20](#)
- ["Activation through Internet" P. 20](#)

Note

While "Activation required" is displayed, you can return the initial setting flow (e.g. IP Address etc.) by tapping .

Activation through the front panel

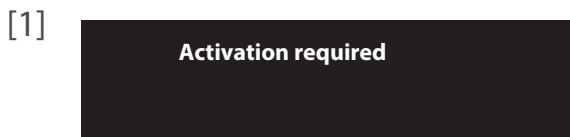

When the message on the left appears, tap [Enter].



Enter the 16-digit activation code.

- key: Increase the number.
- key: Decrease the number.
- key: Move the cursor to the previous digit.
- key: Move the cursor to the next digit.

Tap [Enter] after entering each digit.



Note

To obtain the activation code, please contact your local MUTOH dealer to send it by email.

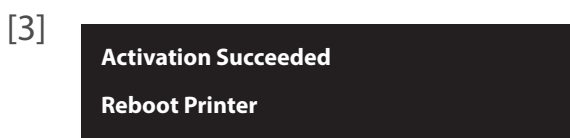

When the message on the left appears, long press the Power button to power off the printer.

- When the message "Power Off" appears on the panel, release the Power button.

Wait for a few seconds and long press the Power button to reboot the printer.



Activation through Internet

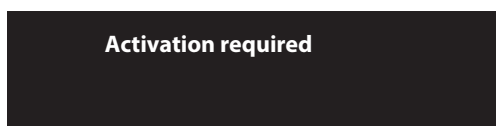

When the message on the left appears on the front panel, follow the instructions on the Printer Activation Guide to activate the printer.

Note

To obtain the activation code and the Printer Activation Guide, access to MUTOH Club from the following URL and click "Register" to complete the user registration.
<https://club.mutoh.co.jp/mutoh/guser/>

Before performing the initial ink charging, the cleaning wiper must be installed on the printer.

Step 3 Installing the cleaning wiper

[1] **Install Wiper
then Tap Enter**

The message on the left appears on the front panel.

- Tap [Enter].



Installed Wiper?

No

The message on the left appears.

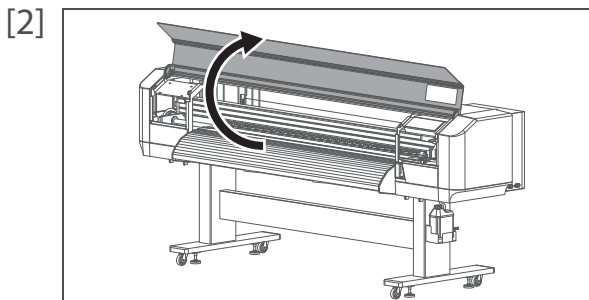

Open the front cover.

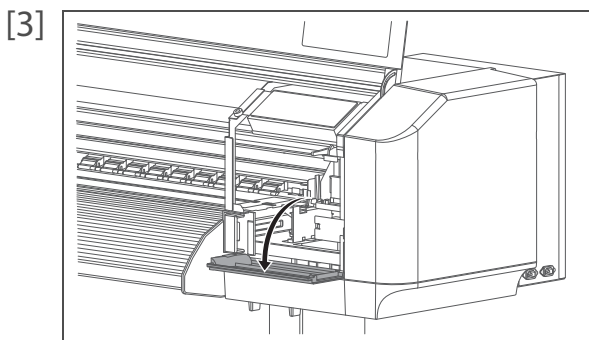

Open the right side of the maintenance cover.

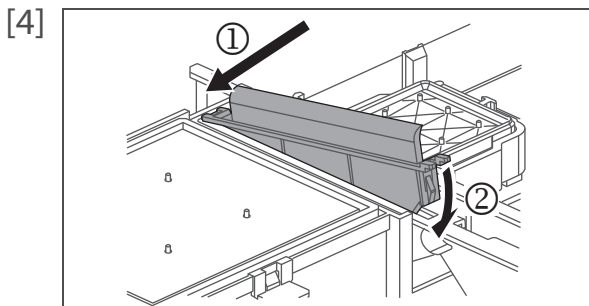

Install the cleaning wiper as follows:

- Insert the back side of the cleaning wiper.
- Then insert the front side of the cleaning wiper until it clicks into place.



**DO NOT touch the rubber on the cleaning wiper with your bare hands.
Skin oil may cause the damage to the print head.**

[5] Close the maintenance cover.

[6] Close the front cover.

[7] **Installed Wiper?**

Yes

- Use or to choose "Installed Wiper? Yes".
- Tap [Enter].



Follow the steps below to perform initial cleaning and initial ink charging.

Step 4 Initial Cleaning - Initial Ink Charging

Items Required (XPJ-1682SR):

- Cleaning bag: ×8
- Ink bag: ×8
4-color setting: Black ×2, Cyan ×2, Magenta ×2, Yellow ×2
7-color setting: Black, Cyan, Magenta, Yellow, Light Cyan, Light Magenta, Light Black, Cleaning Bag
- Ink bag case: ×8

Items Required (XPJ-1641SR):

- Cleaning bag: ×4
- Ink bag: ×4 (Black ×1, Cyan ×1, Magenta ×1, Yellow ×1)
- Ink bag case: ×4

1. Perform initial cleaning

[1]



When the message on the left appears, tap [Enter].



 Note

While "Ink Charge Start -> Enter" is displayed, you can return the initial setting flow (e.g. IP Address etc.) by tapping .

Insert Cleaning Bags

The message on the left will appear.

[2]

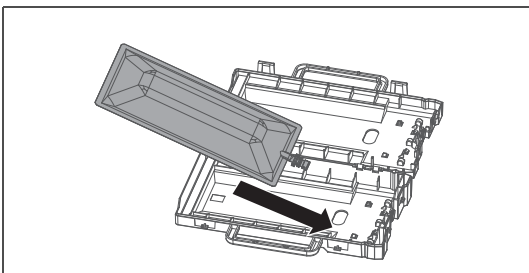

Open the ink bag case to put the cleaning bag into the case.

[3]

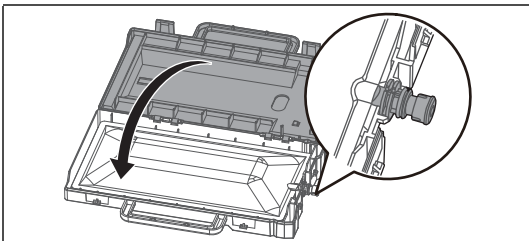

Close the case.

 Important!

Make sure that the spout of cleaning bag is properly fitted into the groove in the case.

If not fitted, the printer cannot correctly detect the cleaning bag.

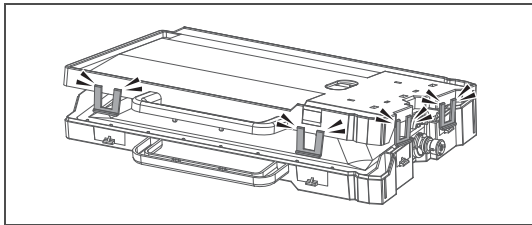

Close the latches (x4) of the case properly.

Important!

**Check that all the latches (x4) are closed.
If not, it may cause cleaner spillage.**

[4] Insert the ink bag cases with cleaning bags and S/C cards into each slot.

- Face the latch side towards you and insert the case into the slot.
- Make sure that they are fully inserted.

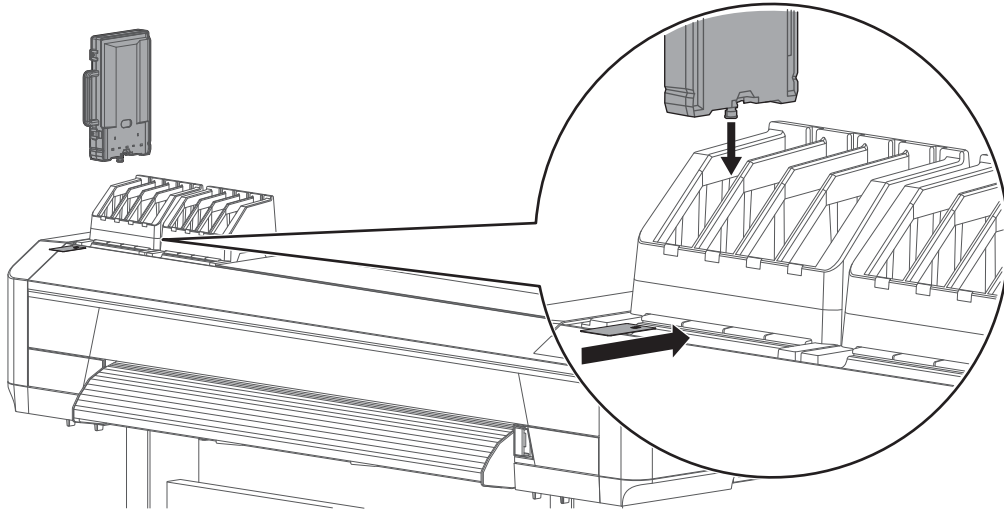

Washing Head

The printer starts filling cleaner.

Remove Bags

When the cleaner filling is complete, the message on the left will appear.

- [5] Remove the ink bag cases and S/C cards from the slots.
 • Store the cleaning bag together with the corresponding S/C card.

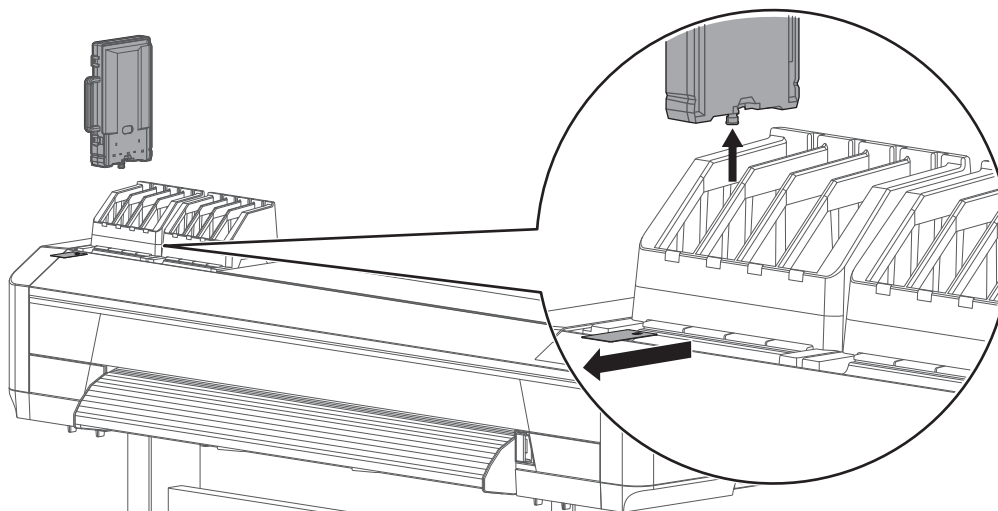

Washing Head

The printer starts discharging cleaner.

2. Perform initial ink charging

- [1] **Wash Retry?** Yes
- Wash Retry?** No

- To finish initial cleaning, use or to choose "Wash Retry? No".
- Tap [Enter].



Note

To perform cleaning again, choose "Wash Retry? Yes".

Insert Ink Bags

The message on the left will appear.

- [2] **3 sec.**
-
- 3 sec.**
- x 3**

Prepare the new ink bag and follow the instructions below to invert it to mix the ink.

- Face the ink spout side upwards for 3 seconds.
- Invert it and count for 3 seconds.
- Repeat 3 times.

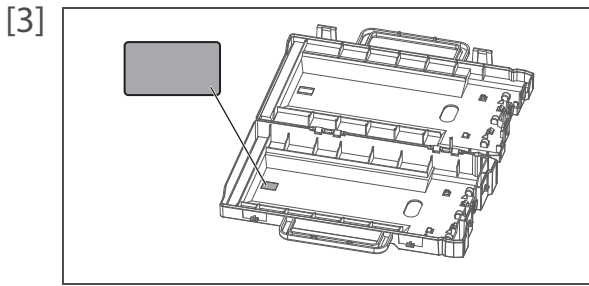

Open an ink case and apply an ink color label onto the inside of the case.

Note

- The ink color label is supplied with the ink case.
- The label should be applied onto the glossy surface of the case.

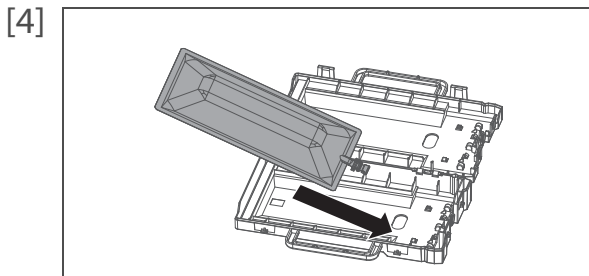

Open the ink bag case to put the ink bag into the case.

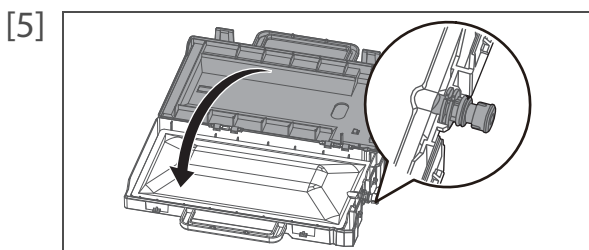

Close the case.

Important!

Check that the spout of ink bag is properly fitted into the groove in the case.

If not fitted, the printer cannot correctly detect the ink bag.

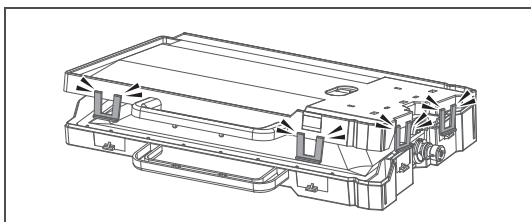

Close the latches (x4) of the case properly.

Important!

Check that all the latches (x4) are closed.

If not, it may cause ink spillage.

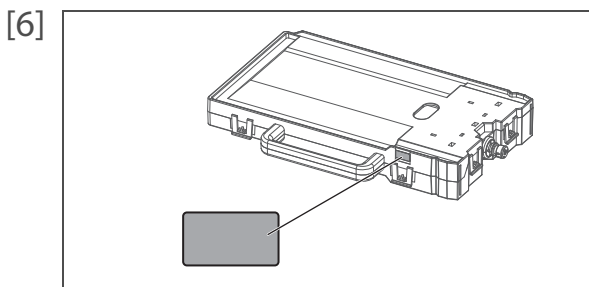

Apply an ink color label onto the outside of the case.

Note

- The label should be applied onto the glossy surface of the case.
- Make sure to match the color of the label with the one applied onto the inside of the case.

[7] (XPJ-1682SR only) Depending on the ink configuration you will use, apply an appropriate ink slot label to the recess on each ink slot. The label placement location and order of ink colors from left to right are shown in the illustration below.

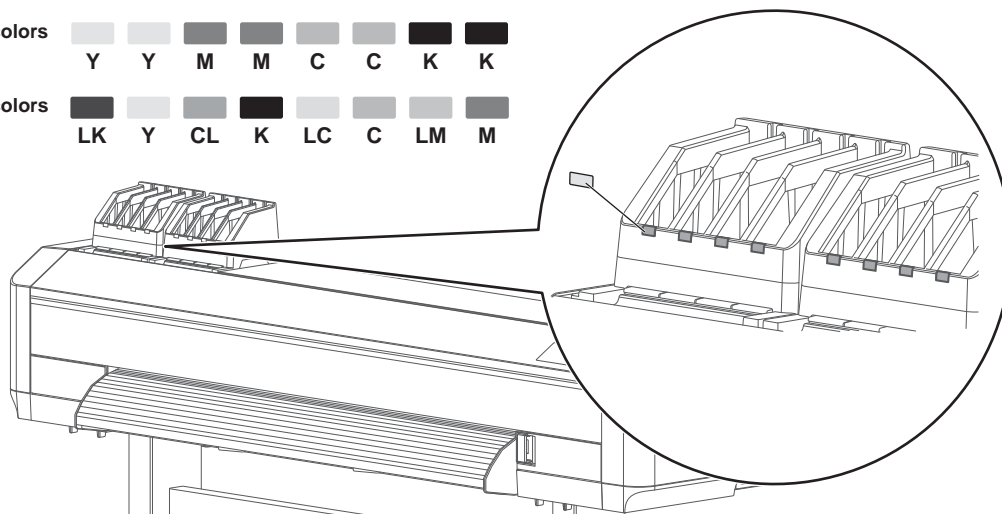
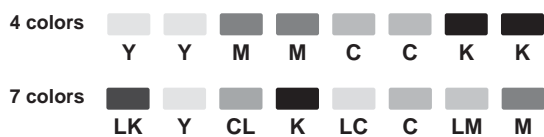

Important!

- The ink slot label is supplied with the printer box.
- Make sure to apply with the correct order of ink colors.

[8] Insert the ink bag cases and S/C cards into each slot.

- Make sure to match the colored label on the ink slot and the colored label on the ink bag.
- Face the latch side towards you and insert the case into the slot.
- Make sure that they are fully inserted.

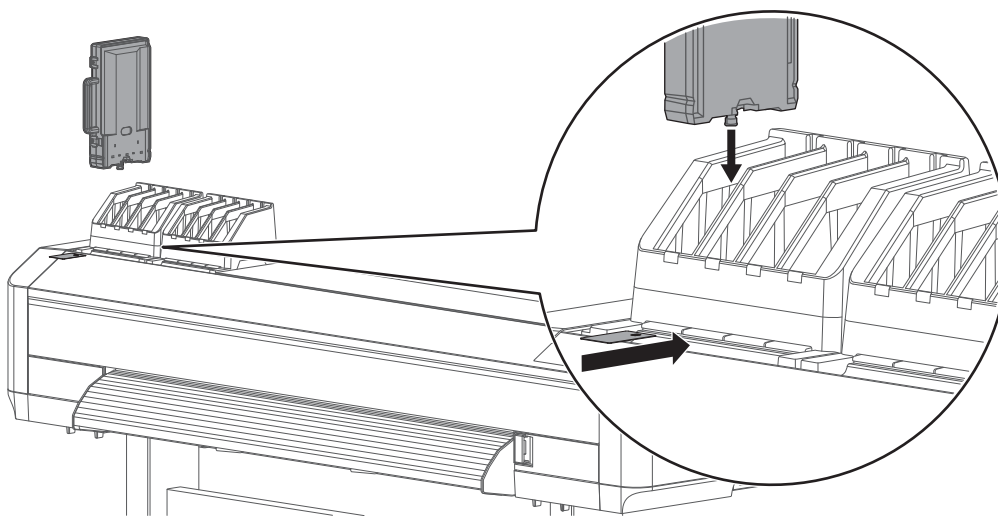

The message on the left appears.

- The printer starts the initial ink charging.

⚠ CAUTION



DO NOT attempt the following actions during ink charging:

- **Power off the printer.**
- **Disconnect the power cord.**
- **Open the front cover.**
- **Open the maintenance cover.**
- **Release the pressure rollers.**

[9]

Media End

PG: Low

Once the ink has been filled, the message on the left will appear on the panel.

- The ink charging is complete.

Test printing

Follow the steps below to load a media into the printer.

Important!

Depending on the size of media, two or more people are required.

Load a roll media into the printer

Items Required:

- Roll media
- Media flange: x2

1. Attach flanges to the media

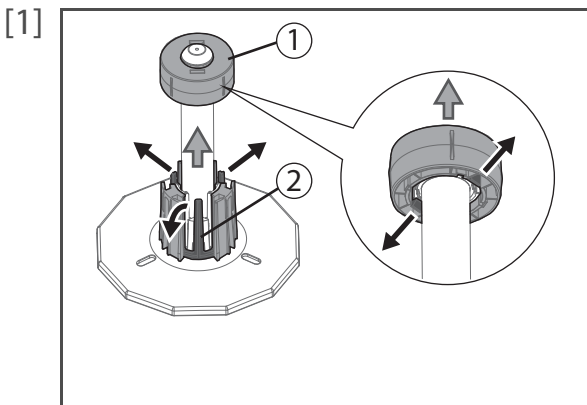

(If you are using 2-inch core roll media), remove the 3-inch adapter from the media flange.

- ①: Pull two tabs on the adapter outward, then remove it from the flange.
- ②: Pull three tabs on the adapter outward, then remove it from the flange.

Note

- If ② adaptor cannot be removed, turn the handle on the flange anti-clockwise to loose (see Step 2), then remove it.
- If you are using 3-inch core roll media, skip this step.

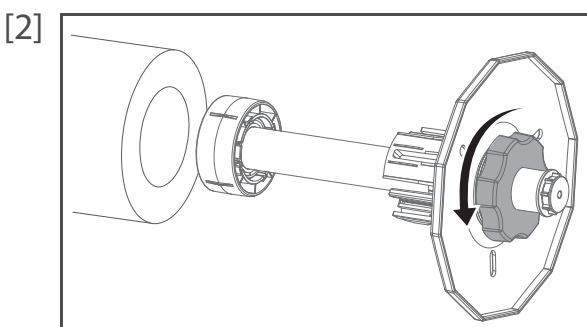

Push the media flange (x2) into the both ends of the media core.

- Before inserting, twist the handle on the flange anticlockwise to unlock it.

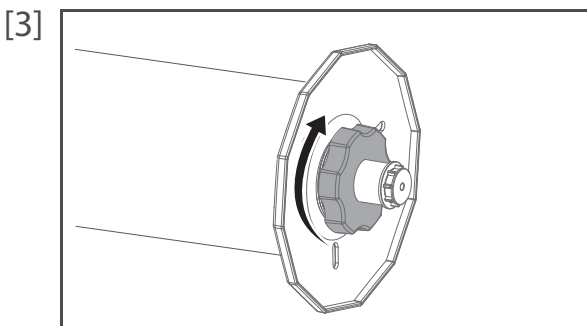

Twist the handle clockwise to lock the flange.

Important!

Check that the flange is firmly locked.

If not, the media can be removed from the flanges, affecting the print quality.

2. Enable torque on media holders

If you want to apply torque to the media holders, follow the steps below.

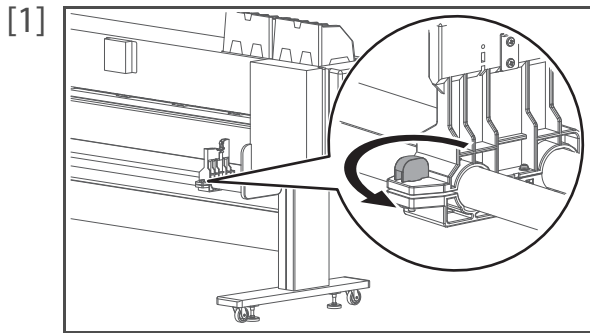

Twist the knob bolt on the right side of the media holder anticlockwise to loosen.

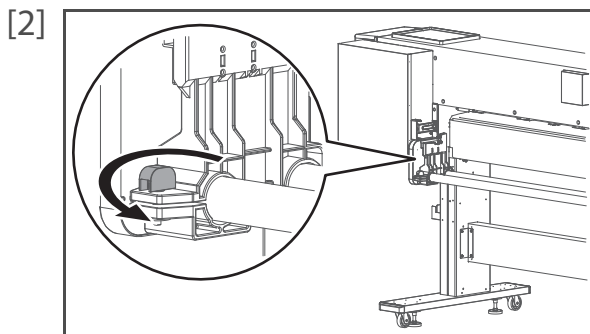

Twist the knob bolt on the **left** side of the media holder anticlockwise to loosen.

[3] Slide both left and right media holders about 30 cm towards the center of the slider for easy access.

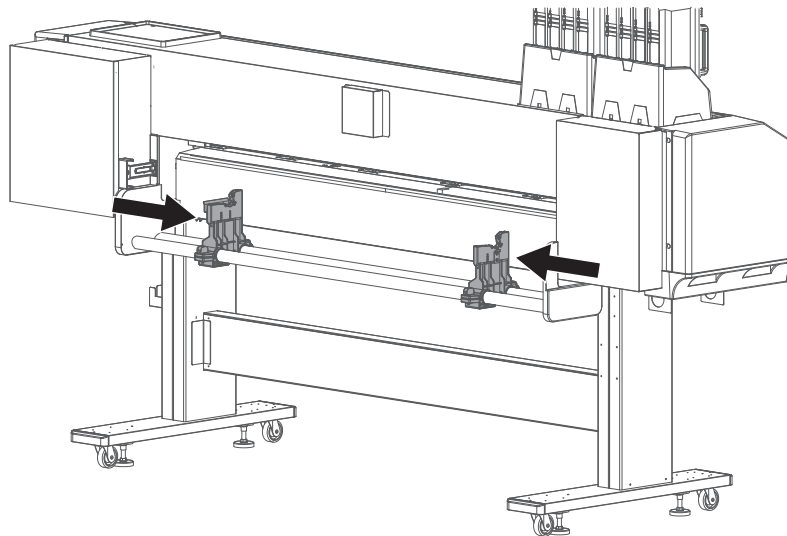

[4] Tighten the knob bolts on both media holders.

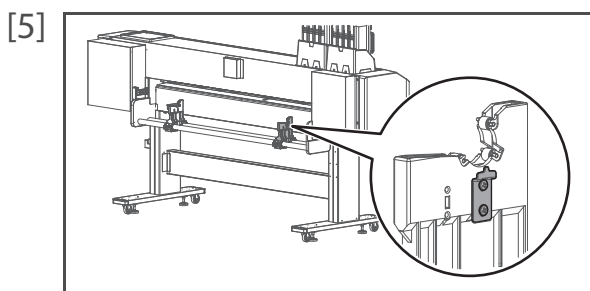

(When looking from the rear side of the printer) Use the screwdriver to loosen two screws securing the roller shaft guide plate to the right media holder.

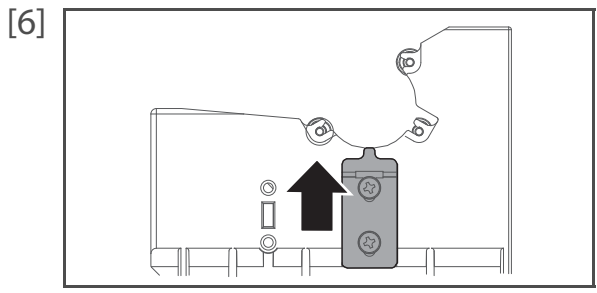

[6] Slide up the roller shaft guide plate as far as it will go and tighten the screws.

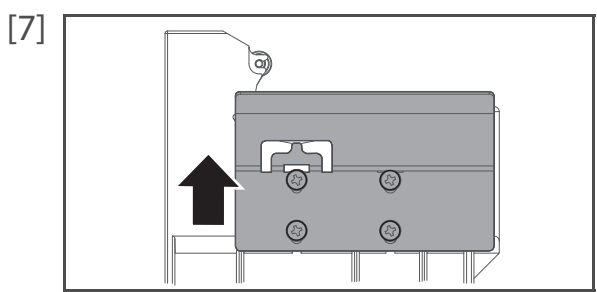

[7] Do the same for the left media holder to slide up the roller shaft guide plate as far as it will go and tighten the screws.

Note

The shape, number of screws, and mounting location differ between left and right guide plates.

[8] Loosen the knob bolts and slide back both media holders to the original position.

[9] Tighten the knob bolts.

3. Place the media onto the media holder

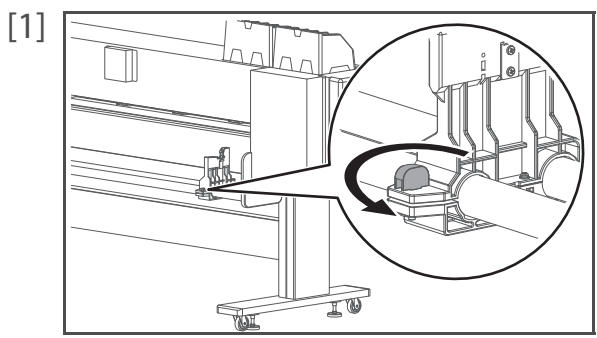

[1] Twist the knob bolt on the right side of the media holder anticlockwise to loosen.

[2] Place the roll media onto the left media holder. Carefully and gently place it on the holder. (If torque is enabled)

- ①: When looking from the left side, check that the protrusion on the roller shaft guide plate is fitted into between two protrusions on the flange end cap.
- ②: When looking from the rear side of the printer, check that the flange end cap is properly placed on the protrusion on the roller shaft guide plate.

Important!

Do not drop or apply excessive impact while placing the media. This will cause damage to the part.

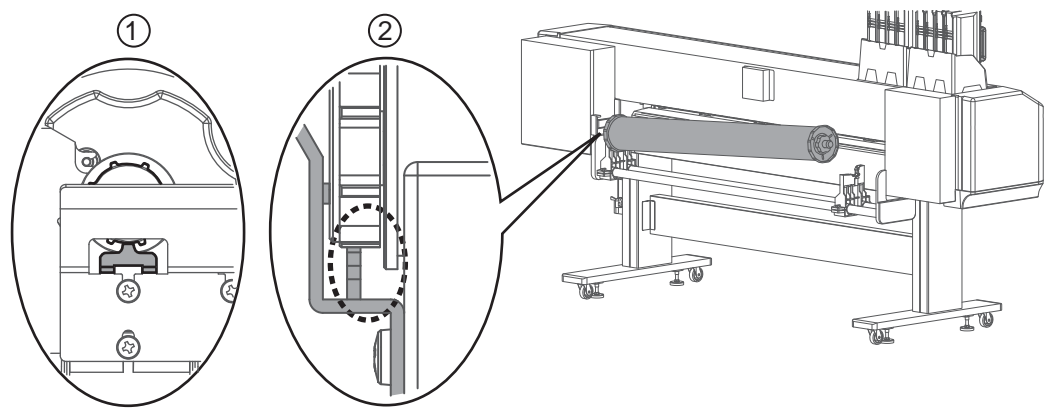

(If torque is disabled)

- Check that the stopper on the shaft is fitted into the slit as shown in the illustration (not on the media holder).

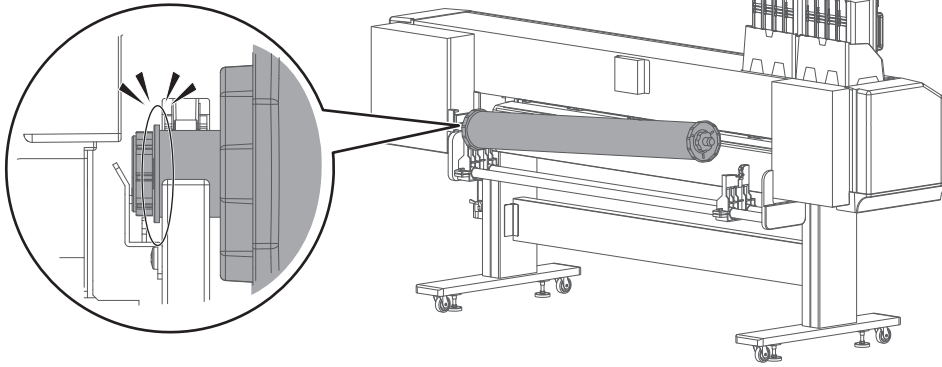

Important!

When you adjust the position of the media holder (left), do not move it more than 450 mm away from the left-hand end. The printer will not be able to detect media.

- [3] Slide the right side of the media holder to place the right side of the flange onto the holder. Place the roll media onto the right media holder. Carefully and gently place it on the holder.

(If torque is enabled)

- ①: When looking from the right side, check that the protrusion on the roller shaft guide plate is fitted into between two protrusions on the flange end cap.
- ②: When looking from the rear side of the printer, check that there is a gap between the protrusion on the roller shaft guide plate and stopper on the shaft.

Important!

- Do not drop or apply excessive impact while placing the media. This will cause damage to the part.
- If the stopper gets contact with the guide plate as "No Good" example below, it may cause damage to the part.

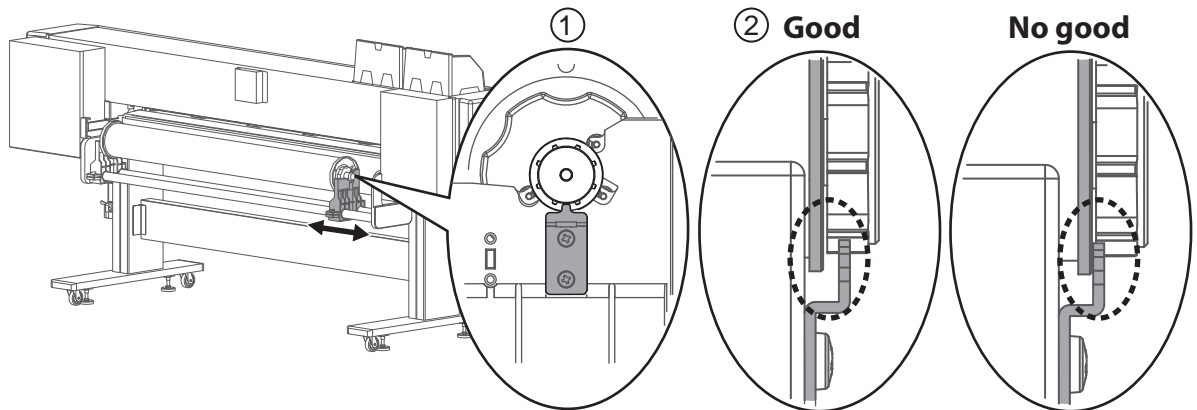

(If torque is disabled)

- Check that the stopper on the shaft is fitted into the slit as shown in the illustration (not on the media holder).

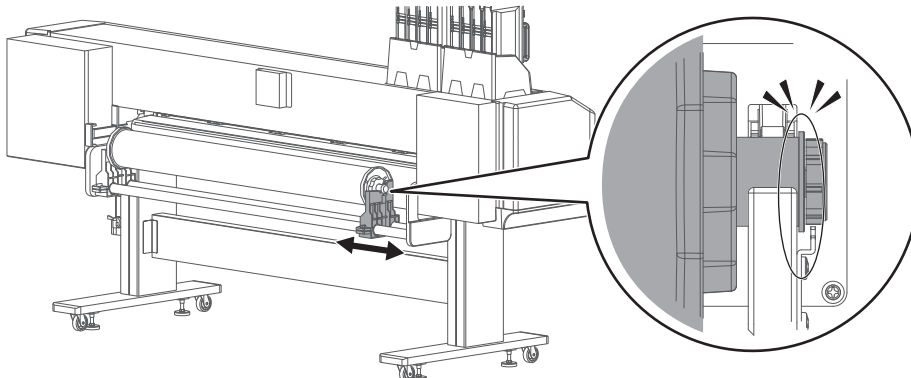

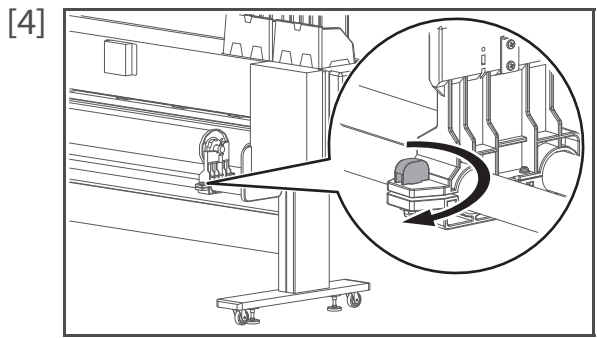

[4] Twist the knob bolt on the right side of the media holder clockwise to tighten.

4. Load the media into the printer

[1] Check that the printer is powered on.

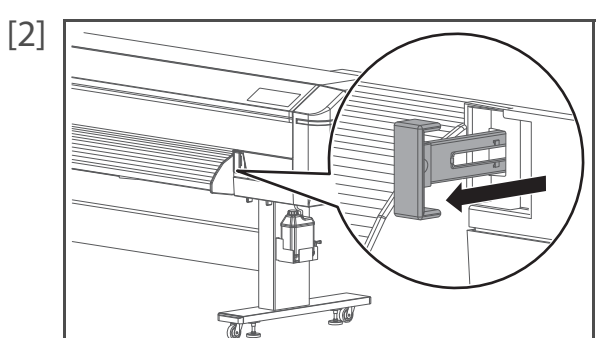

[2] From the front side of the printer, fully pull the media feed lever towards you to release the pressure rollers.

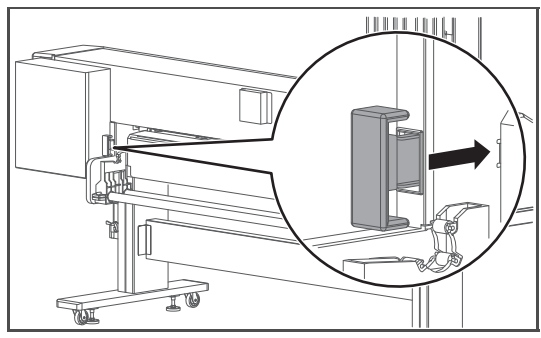

You can access to the media feed lever from the rear side of the printer.

- To release the pressure rollers, push the lever as far as it goes.

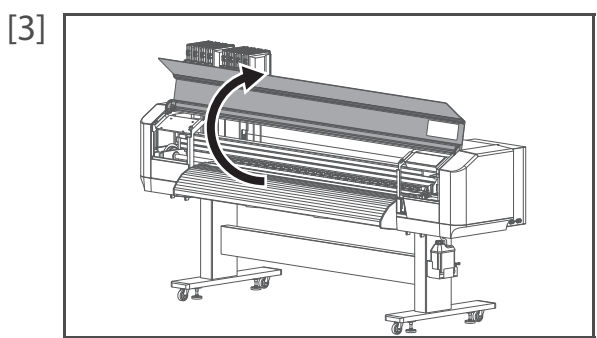

[3] Open the front cover.

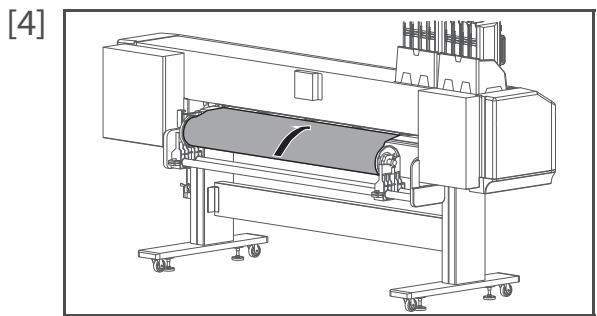

[4] From the rear side of the printer, insert the front edge of the media into the media slot.

 **Note**

Before inserting, rewind the media properly.

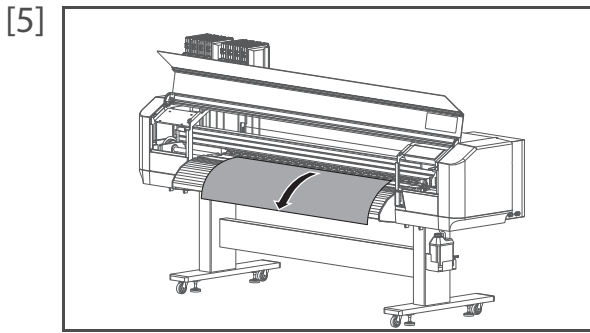

[5] From the front side of the printer, pull the media for approximately 1 m.

[6] While one person holds the front edge of the media, the other person turns the flange to slightly rewind the media onto the roll to remove warp or skew.

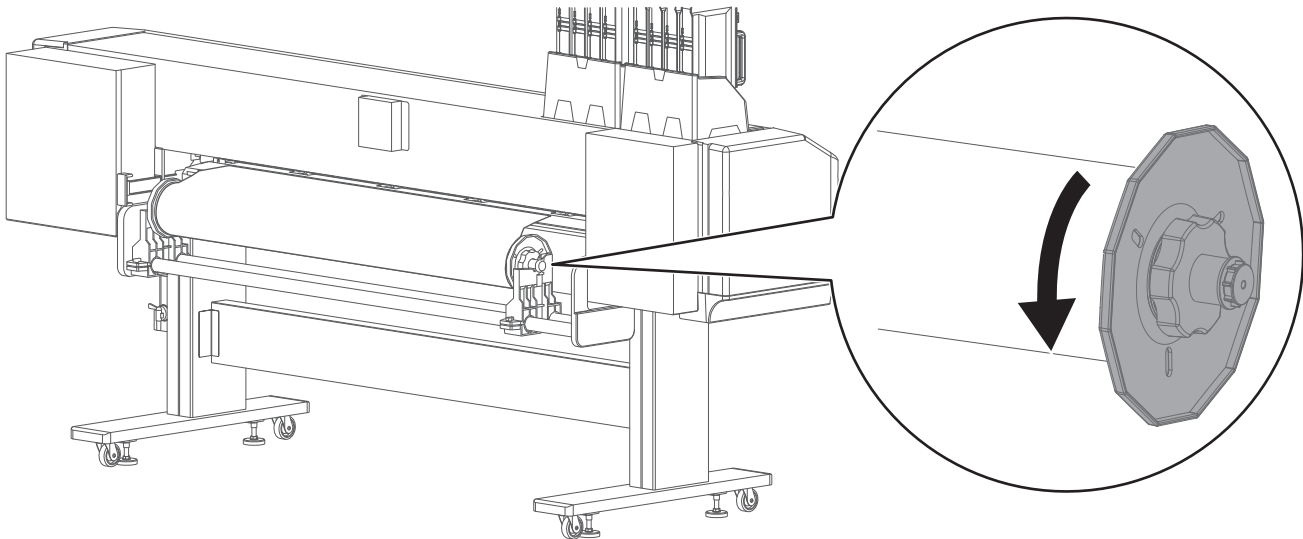

Note

If you remove your hands from the front edge of the media while rewinding, the media can be removed from the media slot.

[7] Check that the right-hand edge of the media is located at the left side of the media guide line. If not, print quality can be affected.

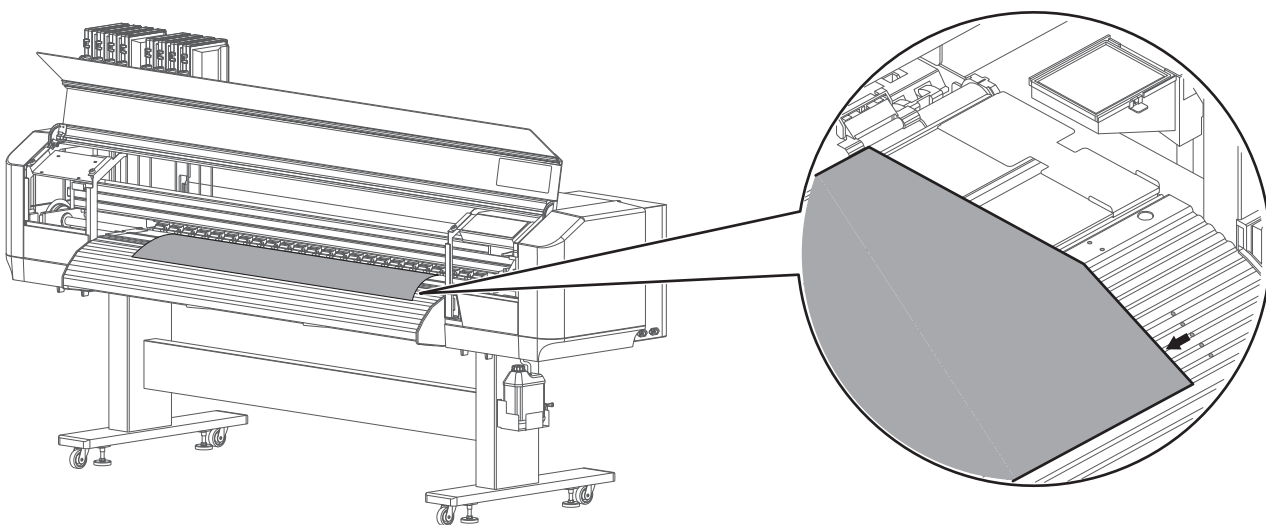

[8] If needed, use a slide lock lever on the pressure rollers to individually cancel or reduce the pressure. Operation Manual "Canceling or reducing pressure rollers individually" P. 42

5. After loading the media...

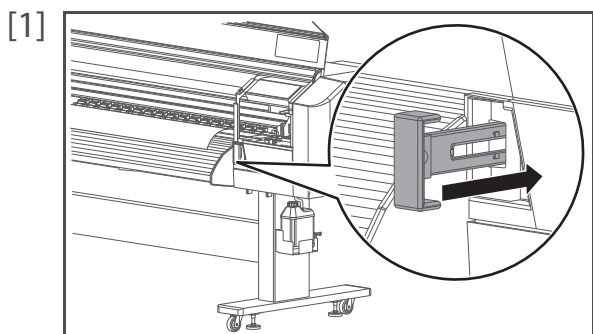

From the front side of the printer, push the media feed lever to hold the media flat with pressure rollers.

Note

Using this lever, the pressure applied to the rollers can be changed between High and Normal. Normally push the lever until it clicks to apply normal pressure.

📖 Operation Manual "Changing holddown pressure using media feed lever" P.41

- [2] Check that the pressure rollers hold down the both edges of the media properly.
- If it holds as a "No Good" example, pull the media feed lever towards you as much as possible, then adjust the position of the left or right side of the media holder until the both edges of the media are held down properly (see ["Place the media onto the media holder" P. 30](#) for more details).

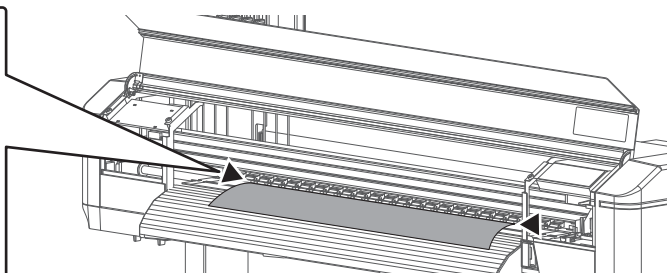
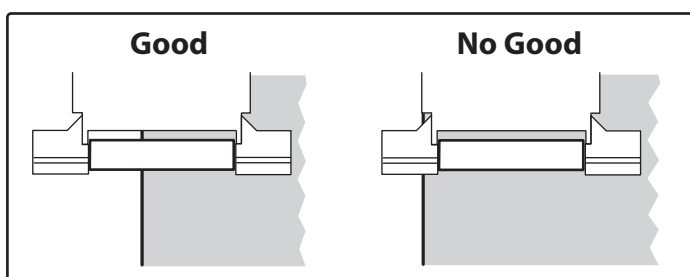

- [3] Place the edge holders on both edges of the media.

Important!

In the default setting, the printer starts printing with 5 mm margin on the sides.

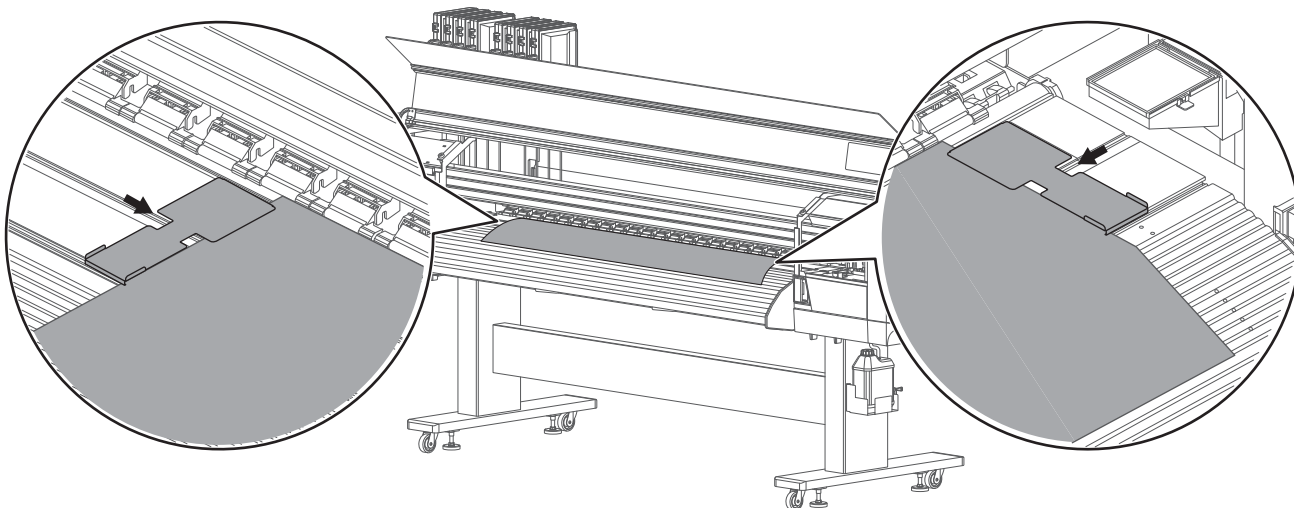

Tap [Home].

[5] Menu 1
Setup

Tap .



[6] Setup3
Side Margin



Tap  until the menu on the left appears.

• Tap .



[7] Side Margin :
(5 - 25) 10 mm

Set the side margin to 10 mm minimum.

- Use  or  to choose the alignment method.
- Tap [Enter].



 Note

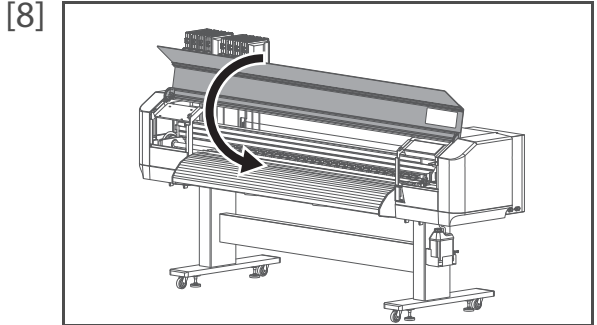

- The side margin can be set between 5 mm and 25 mm.



Close the front cover.

[9] User: Type 1 OK?

“User: Type** OK?” appears on the front panel.

- Use  or  to choose the correct user type and tap [Enter] to start media initialization.
- End the media loading.



Nozzle Check and Cleaning

Run a nozzle check print. If nozzle missing is found, perform cleaning.

1. Run a nozzle check print

[1] Load a roll media for Nozzle check.
👉 ["Test printing" P. 28](#)

[2] Tap .

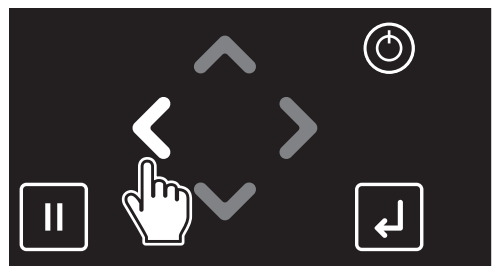

[3] Tap [Enter].
• The printer will print the nozzle check pattern.



[4] Look at the print.
• If you find missing or thin lines on the print, go to ["Perform cleaning" P. 37](#).
• If all lines are clearly printed, you can start printing.

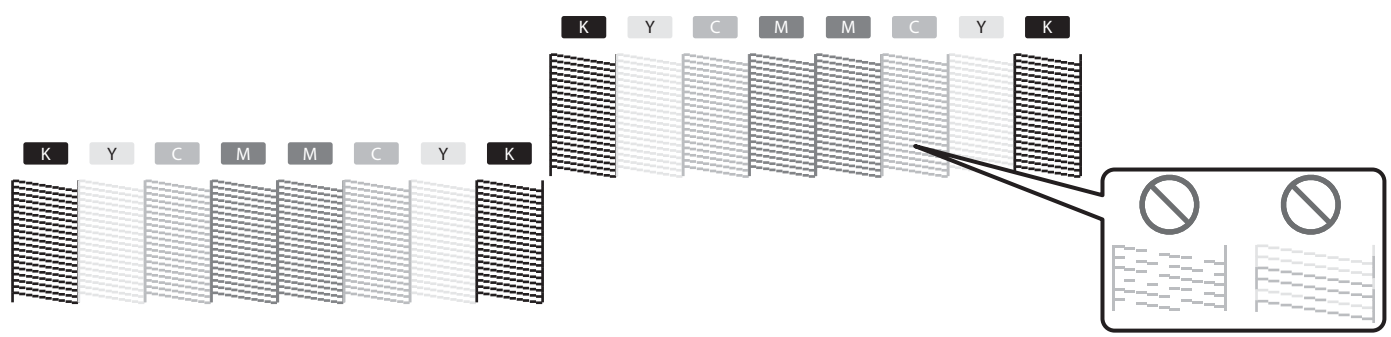

Note

- The pattern shown above is an example when printed on XPJ-1682SR with 4-color configuration.
- Printer information (Data and time printed, serial number, firmware version) is printed next to the pattern.

Important!

If you run a nozzle check print immediately after the initial ink charging, the following symptoms may occur:

- **lines are faded.**
- **patterns are partially missing.**

In such cases, follow the instructions on the operation manual "Menu 3: Cleaning" to perform "Little Charge" P.99.

If it does not help to solve the problem, leave the printer for one hour or more, then perform cleaning or "Little Charge" again.

If the problem still persists, contact your local MUTOH dealer.

2. Perform cleaning

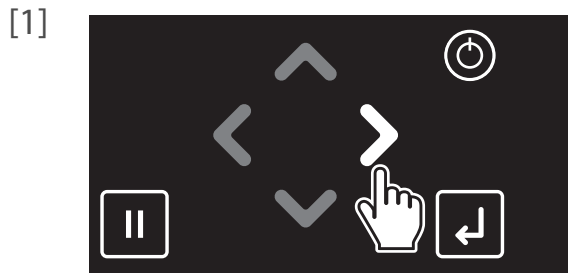

Tap .

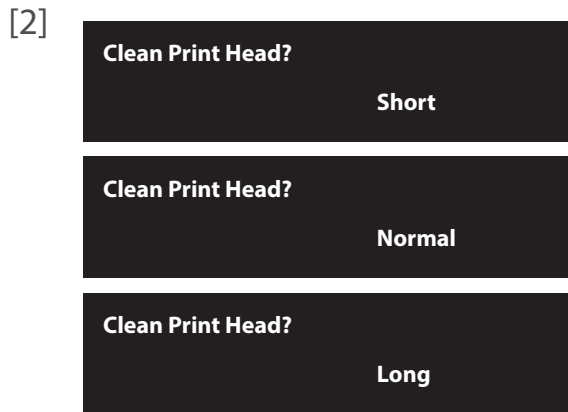

Use  or  to choose the cleaning mode.

Tap [Enter].

- The printer will start cleaning.



[3] Run a nozzle check print again.

 ["Run a nozzle check print" P. 36](#)

- If the problem persists, repeat normal cleaning until all nozzles are clear.
To perform "Short", "Long", "Little Charge", and "Initial Charge", see the operation manual "Head Cleaning" P.117.

Note

Before you start printing an image, connect your computer and configure the IP address, subnet mask, and default gateway.

 Operation manual "Setup 23: IP Address", "Setup 24: Subnet Mask", "Setup 25: Gateway" P.89

Important!

You must perform media feed adjustment before printing an image.

 Operation manual "Media feed adjustment" P.38

Installing MUTOH Status Monitor

Before you start printing an image, MUTOH Status Monitor (MSM) must be installed on your computer. After installing MSM, follow the instructions on the MSM operation manual to configure MSM initial setup, printer registration.

👉 MUTOH Status Monitor Operation manual "Initial Setting"

- The CD supplied with your printer contains the following software and operation manual:

MUTOH LFP Finder	When you set up the printer using the Startup wizard, assign IP address to your printer, so that it can communicate with the computer.
Printer driver	Sends print data from the computer to the printer. It also allows to change the print settings. Note If you use the Windows printer driver, select the ink type and the ink configuration settings of your printer (see "Displaying the Printing Preferences screen of printer driver" of the Operation Manual).
MUTOH Status Monitor (MSM)	Allows you to view printer status, change printer's settings and run a test printing.
Layout and Print Tool 2	Simple layout and print application.
Manuals (for printer and software)	To view the operation manual, see " Viewing Operation Manual " P. 39. The following documents are available in the PDF format. <ul style="list-style-type: none">• XPJ-1641SR / XPJ-1682SR Operation manual "Operations and Maintenance Methods"• XPJ-1641SR / XPJ-1682SR Startup Guide (This manual)• MUTOH Status Monitor Operation manual• Layout and Print Tool 2 Operation manual

🔊 Important!

- **Make sure to install MSM stored in the supplied CD.**

[1]

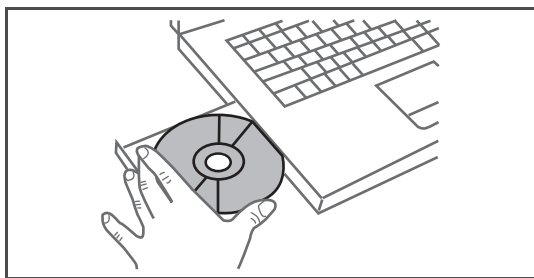

Insert the supplied CD into the CD-ROM drive.

📝 Note

- The Startup Wizard will start up automatically.
- If the Startup wizard does not automatically start, right click the icon of CD-ROM drive, open the contents of CD with [Open], and double click MpTotalInst.exe.

[2] Follow the instructions on the Startup Wizard to install softwares.

📝 Note

- Please keep the supplied CD at hand. You will need it for reinstallation.
- If lost, you can download from MUTOH Club (user registration is required). (MUTOH Club) <https://club.mutoh.co.jp/mutoh/guser>

Viewing Operation Manual

You can view each operation manual stored in the supplied CD as follows:

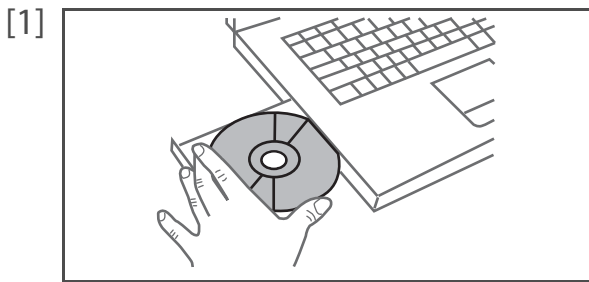

Insert the supplied CD into the CD-ROM drive.

- The Startup Wizard will start up automatically.
- If the Startup wizard does not automatically start, right click the icon of CD-ROM drive, open the contents of CD with [Open], and double click MpTotalInst.exe.

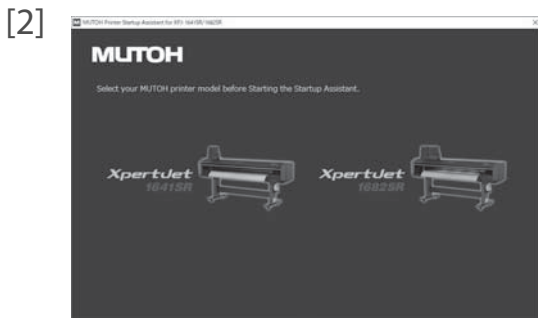

Choose the printer model.

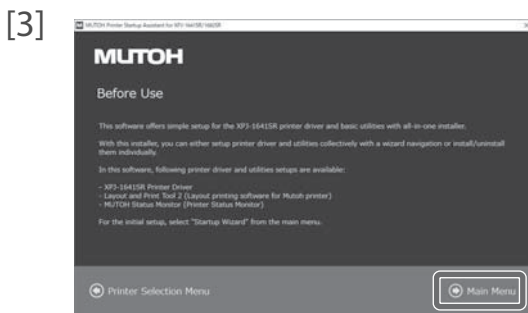

Click [Main Menu].

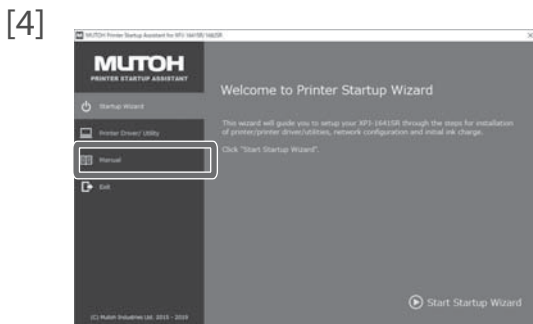

Click [Manual].

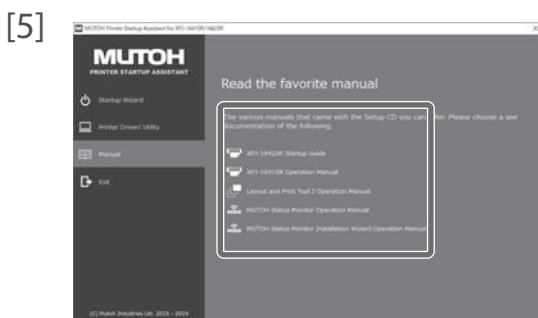

Click the manual you want to read.

Site Preparation

Unpacking

Assembling

Connecting Power and Network

Printer Initial Setup

Test printing

Installing MSM

Viewing Operation Manual

Safety Precautions

Safety Precautions

Important Notice

For Users in Europe



The CE marking is a mandatory European marking for certain product groups to indicate conformity with the essential health and safety requirements set out in European Directives.

By affixing the CE marking, the manufacturer, his authorized representative, or the person placing the product on the market or putting it into service ensures that the item meets all the essential requirements of all applicable EU directives and that the applicable conformity assessment procedures have been applied.

For Users in the United States

This equipment has been tested and found to comply with the limits for a Class A digital device, pursuant to Part 15 of the FCC Rules. These limits are designed to provide reasonable protection against harmful interference when the equipment is operated in a commercial environment. This equipment generates, uses, and can radiate radio frequency energy and, if not installed and used in accordance with the instruction manual, may cause harmful interference to radio communications.

Operation of this equipment in a residential area is likely to cause harmful interference in which case the user will be required to correct the interference at his own expense.

Safety Notices

Signification of WARNING and CAUTION

WARNING	Failure to follow the instruction may result in serious injury or death.
CAUTION	Failure to follow the instruction may result in minor injury or damage to the product.

Meaning of symbols

Warning symbol	Meaning
	Indicates an action that must be avoided.
	Indicates an important instruction that must be followed.



Note

Refer to "Main components of your printer" P.9 of operation manual for names of each component in the main body.

WARNING



DO NOT install this product in a location with high humidity and dust.

This could result in an electrical shock or fire.



DO NOT use a damaged power cord.

This could result in an electrical shock or fire.



DO NOT connect or disconnect the power plug with wet hands.

This could result in an electrical shock.



DO NOT connect an earth wire to the following places:

- **Gas pipe**
It has potential risks of fire and explosion.
- **Earth wire of telephone cables or lighting rods**
Large current may flow when the lightning strikes.
- **Water pipe or faucet**
It may not work properly if a plastic pipe is connected to the pipe.



DO NOT insert or drop metal or flammable objects into the printer through openings such as vent.

This could result in an electrical shock or fire.



If foreign objects or liquid accidentally entered the inside the product, do not use the printer.

It could result in an electrical shock or fire.

Immediately power off the printer and disconnect the power plug from the outlet. Then contact the MUTOH customer support.



DO NOT block the vent on the product with cloth or other materials.

If covered, the inside the product gets hot, resulting in fire.



Follow the precautions below when handling the power cord.

- **Do not modify power cords.**
- **Do not place heavy objects on power cords.**
- **Do not bend, twist, or pull on power cords.**
- **Do not route power cords near heating equipment.**



Follow the precautions below when handling the power plug.

- **Do not allow dust or foreign objects to accumulate around the power plug.**
- **Firmly insert the power plug into the wall outlet.**



Use the designated power cord only.

Failure to do so could result in an electrical shock or fire.



Plug the power cord into the wall outlet.

DO NOT use power strips. This could result in fire.



Plug the power cords into the wall outlet that has the earth connection and make sure to connect the earth.

If the earth is not connected, an electrical shock or fire may occur.



Plug two power cords into the wall outlet with the same voltage.

Failure to do so may damage the electrical circuit.



Make sure to connect an earth wire to the earth connection that meets the following requirements:

- Earth terminal of power socket
- An earth wire with a copper plate which is buried at 650 mm or more in the ground.



Be sure to use the designated power cords.

- Failure to do so could result in an electrical shock or fire. For the designated power cord, please contact your local MUTOH dealer.
- The power cord should have the protective ground terminal and make sure to plug in securely.
- Use the power cords which meet the safety standard, voltage and plug shape of the country to use this product.



Make sure to follow the instruction on this manual to plug the power cord into the wall outlet.

Failure to do so could result in fire.



Never open the covers securing with screws.

This could result in an electrical shock or damage to the printer.



If you are not using the product for a long period of time, disconnect the power plug from the wall outlet.



Ensure that no moisture enters the product.

This could result in an electrical short circuit.



DO NOT use flammable liquid on the media guide.

This could result in fire.

Installation Precautions

WARNING



- When installing this product, avoid the location where**
- **the floor is not flat and level.**
 - **the product gets vibration from the neighboring devices.**
- Failure to do so may result in injury from a fall.

CAUTION



- DO NOT tilt or turn the product upside down.**
The ink inside the printer may spill.
MUTOH cannot guarantee that the printer can run properly.



Keep this product level when moving.



Minimum four people are required for unpacking or moving this product.



Before taking out the printer from the packing box, remove the plastic sheet wrapped around the printer first.

Failure to do so may cause slip or damage to the product.



This equipment is not suitable for use in locations where children are likely to be present.

Product Handling

WARNING



- DO NOT sit on or place heavy objects on the product.**
Failure to do so may result in injury from a fall.

CAUTION



- Follow the precautions below when cleaning the cleaning wiper or around the print head:**
- **DO NOT reuse the cleaning stick.**
Dust on the stick may damage the print head.



Follow the precautions below when cleaning around the print head:

- **DO NOT touch the surface of the print head.**
This may damage the print head.
- **DO NOT touch the cleaning stick with your finger.**
The oil from your finger may damage the print head.
- **DO NOT use water when cleaning with cleaning sticks.**
This may damage the print head.



- Follow the precautions below when cleaning the cleaning wiper.**
- **DO NOT touch the cleaning wiper and head cap unit with your bare hands.**
The skin oil from your finger can result in improper cleaning.
 - **Use a dry cleaning stick to clean the wiper. DO NOT moisten the stick with water.**
This may cause the nozzle clogs.

Product Handling (continued)



Keep the work area well-ventilated.

Failure to do so may cause nausea from ink odor or fire hazard.



DO NOT touch the media guide while printing or the heater is on.

The media guide can be very hot, causing burn injuries.



DO NOT attempt the following actions during ink charging:

- Power off the printer.
- Disconnect the power cord.
- Open the front cover.
- Open the maintenance cover.
- Release the pressure rollers.



DO NOT use volatile chemicals such as thinner, benzene or alcohol for cleaning.

This will damage the paint on the printer.



The media guide can be very hot immediately after printing.

Wait until it cools down.

Ink Handling



WARNING



Waste ink collected from this product is classified as industrial waste. Dispose of waste ink according to the local waste disposal regulations.



CAUTION



Do not disassemble Ink bags.

If disassembled, ink may come into contact with your eyes or skin, causing irritation or allergic reaction.



DO NOT drop or hit an ink bag.

Ink may leak from the bag.



Before using the ink bag on the printer, make sure to read the Safety Data Sheet (SDS).



Wear the protective gloves and avoid contact with your eyes or skin.

Eye or skin contact may cause slight irritation or bloodshot eyes. If in eyes or on skin, immediately flush with water. If irritation is present, seek medical advice/attention immediately.

Warning Labels

Warning labels are applied onto the product where special attention is required. Read the messages on the labels and always follows the instructions. If the labels are peeled off or become dirty, contact your local MUTOH dealer to get new one.

- Site Preparation
- Unpacking
- Assembling
- Connecting Power and Network
- Printer Initial Setup
- Test printing
- Installing MSM
- Viewing Operation Manual
- Safety Precautions

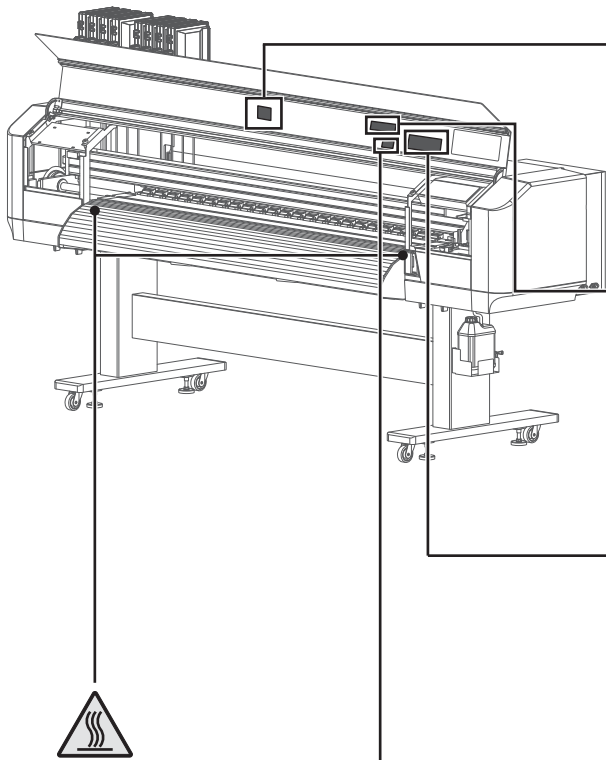

CAUTION / ATTENTION / 注意

- ◆ Sharp Edges. Do not touch steel belt.
- ※ You may be injured.
- ◆ Ne pas toucher les bords de la bande métallique, car ceux-ci sont tranchants.
- ※ Vous pourriez vous blesser.
- ◆ スチールベルトは端が鋭く尖っていますので触らないでください。
- ※ けがをする恐れがあります。

Steel belt
Bande métallique
スチールベルト

Cut Hazard Label for Steel Belt

CAUTION Do not insert your fingers the cutting blade inside may injure your fingers.

ATTENTION N'introduisez pas vos doigts. La lame reclusée qui est à l'intérieur peut vous blesser.

注意 カッター刃でけがをする可能性がありますので、指を入れないでください。

Cut Hazard Label for Cutter

CAUTION / ATTENTION / 注意

- ◆ Do not give a direct wind from a fan or air conditioner to the machine.
- ◆ Do not use the printer in the humid weather causing clogging that affects ink getting, and you will not be able to obtain satisfactory printing results.
- ◆ Normal clearing should be done once a week if the printer is not used for a long period.
- ◆ If the printer is left without clearing the ink will be hardened inside the head nozzle, and may cause the head trouble.
- ◆ Do not open the front cover while printing. Otherwise, the ink inside the nozzle printing. Color printing result might not be obtained.
- ◆ Please remove the media and hold the cover up when not using for a long time. Due to the environment condition, media flow and wrinkles might happen that does not obtain the good result.
- ◆ Please handle printer and paper handling with care not to be heated. Temperature setting. Allowance of being heated.
- ◆ Ne pas exposer directement l'imprimante aux courants d'air des appareils de ventilation ou de climatisation.
- ◆ Il est courant d'être peut affecter la projection d'encre, empêchant ainsi l'obtention d'une qualité d'impression satisfaisante, ou entraîner un dysfonctionnement de la tête d'impression, suite à l'assèchement de l'encre à l'intérieur des buses.
- ◆ Si vous n'utilisez pas l'imprimante pendant une longue période, effectuez un nettoyage normal une fois par semaine.
- ◆ Si vous ne nettoyez pas régulièrement, l'encre durcit à l'intérieur des buses et peut provoquer des problèmes de tête.
- ◆ Si vous ouvrez le couvercle avant l'impression, l'encre peut être projetée à l'intérieur de la tête d'impression, ce qui peut entraîner un dysfonctionnement de la tête d'impression.
- ◆ Si vous ne retirez pas le média et maintenez le couvercle ouvert pendant une longue période, l'encre peut être projetée à l'intérieur de la tête d'impression, ce qui peut entraîner un dysfonctionnement de la tête d'impression.
- ◆ Si vous n'utilisez pas l'imprimante pendant une longue période, effectuez un nettoyage normal une fois par semaine.
- ◆ Si vous ne nettoyez pas régulièrement, l'encre durcit à l'intérieur des buses et peut provoquer des problèmes de tête.
- ◆ Si vous ouvrez le couvercle avant l'impression, l'encre peut être projetée à l'intérieur de la tête d'impression, ce qui peut entraîner un dysfonctionnement de la tête d'impression.
- ◆ Si vous ne retirez pas le média et maintenez le couvercle ouvert pendant une longue période, l'encre peut être projetée à l'intérieur de la tête d'impression, ce qui peut entraîner un dysfonctionnement de la tête d'impression.
- ◆ Please handle printer and paper handling with care not to be heated. Temperature setting. Allowance of being heated.
- ◆ Ne pas exposer directement l'imprimante aux courants d'air des appareils de ventilation ou de climatisation.
- ◆ Il est courant d'être peut affecter la projection d'encre, empêchant ainsi l'obtention d'une qualité d'impression satisfaisante, ou entraîner un dysfonctionnement de la tête d'impression, suite à l'assèchement de l'encre à l'intérieur des buses.
- ◆ Si vous n'utilisez pas l'imprimante pendant une longue période, effectuez un nettoyage normal une fois par semaine.
- ◆ Si vous ne nettoyez pas régulièrement, l'encre durcit à l'intérieur des buses et peut provoquer des problèmes de tête.
- ◆ Si vous ouvrez le couvercle avant l'impression, l'encre peut être projetée à l'intérieur de la tête d'impression, ce qui peut entraîner un dysfonctionnement de la tête d'impression.
- ◆ Si vous ne retirez pas le média et maintenez le couvercle ouvert pendant une longue période, l'encre peut être projetée à l'intérieur de la tête d'impression, ce qui peut entraîner un dysfonctionnement de la tête d'impression.
- ◆ Please handle printer and paper handling with care not to be heated. Temperature setting. Allowance of being heated.
- ◆ Ne pas exposer directement l'imprimante aux courants d'air des appareils de ventilation ou de climatisation.
- ◆ Il est courant d'être peut affecter la projection d'encre, empêchant ainsi l'obtention d'une qualité d'impression satisfaisante, ou entraîner un dysfonctionnement de la tête d'impression, suite à l'assèchement de l'encre à l'intérieur des buses.
- ◆ Si vous n'utilisez pas l'imprimante pendant une longue période, effectuez un nettoyage normal une fois par semaine.
- ◆ Si vous ne nettoyez pas régulièrement, l'encre durcit à l'intérieur des buses et peut provoquer des problèmes de tête.
- ◆ Si vous ouvrez le couvercle avant l'impression, l'encre peut être projetée à l'intérieur de la tête d'impression, ce qui peut entraîner un dysfonctionnement de la tête d'impression.
- ◆ Si vous ne retirez pas le média et maintenez le couvercle ouvert pendant une longue période, l'encre peut être projetée à l'intérieur de la tête d'impression, ce qui peut entraîner un dysfonctionnement de la tête d'impression.
- ◆ Please handle printer and paper handling with care not to be heated. Temperature setting. Allowance of being heated.
- ◆ Ne pas exposer directement l'imprimante aux courants d'air des appareils de ventilation ou de climatisation.
- ◆ Il est courant d'être peut affecter la projection d'encre, empêchant ainsi l'obtention d'une qualité d'impression satisfaisante, ou entraîner un dysfonctionnement de la tête d'impression, suite à l'assèchement de l'encre à l'intérieur des buses.
- ◆ Si vous n'utilisez pas l'imprimante pendant une longue période, effectuez un nettoyage normal une fois par semaine.
- ◆ Si vous ne nettoyez pas régulièrement, l'encre durcit à l'intérieur des buses et peut provoquer des problèmes de tête.
- ◆ Si vous ouvrez le couvercle avant l'impression, l'encre peut être projetée à l'intérieur de la tête d'impression, ce qui peut entraîner un dysfonctionnement de la tête d'impression.
- ◆ Si vous ne retirez pas le média et maintenez le couvercle ouvert pendant une longue période, l'encre peut être projetée à l'intérieur de la tête d'impression, ce qui peut entraîner un dysfonctionnement de la tête d'impression.
- ◆ Please handle printer and paper handling with care not to be heated. Temperature setting. Allowance of being heated.
- ◆ Ne pas exposer directement l'imprimante aux courants d'air des appareils de ventilation ou de climatisation.
- ◆ Il est courant d'être peut affecter la projection d'encre, empêchant ainsi l'obtention d'une qualité d'impression satisfaisante, ou entraîner un dysfonctionnement de la tête d'impression, suite à l'assèchement de l'encre à l'intérieur des buses.
- ◆ Si vous n'utilisez pas l'imprimante pendant une longue période, effectuez un nettoyage normal une fois par semaine.
- ◆ Si vous ne nettoyez pas régulièrement, l'encre durcit à l'intérieur des buses et peut provoquer des problèmes de tête.
- ◆ Si vous ouvrez le couvercle avant l'impression, l'encre peut être projetée à l'intérieur de la tête d'impression, ce qui peut entraîner un dysfonctionnement de la tête d'impression.
- ◆ Si vous ne retirez pas le média et maintenez le couvercle ouvert pendant une longue période, l'encre peut être projetée à l'intérieur de la tête d'impression, ce qui peut entraîner un dysfonctionnement de la tête d'impression.
- ◆ Please handle printer and paper handling with care not to be heated. Temperature setting. Allowance of being heated.
- ◆ Ne pas exposer directement l'imprimante aux courants d'air des appareils de ventilation ou de climatisation.
- ◆ Il est courant d'être peut affecter la projection d'encre, empêchant ainsi l'obtention d'une qualité d'impression satisfaisante, ou entraîner un dysfonctionnement de la tête d'impression, suite à l'assèchement de l'encre à l'intérieur des buses.
- ◆ Si vous n'utilisez pas l'imprimante pendant une longue période, effectuez un nettoyage normal une fois par semaine.
- ◆ Si vous ne nettoyez pas régulièrement, l'encre durcit à l'intérieur des buses et peut provoquer des problèmes de tête.
- ◆ Si vous ouvrez le couvercle avant l'impression, l'encre peut être projetée à l'intérieur de la tête d'impression, ce qui peut entraîner un dysfonctionnement de la tête d'impression.
- ◆ Si vous ne retirez pas le média et maintenez le couvercle ouvert pendant une longue période, l'encre peut être projetée à l'intérieur de la tête d'impression, ce qui peut entraîner un dysfonctionnement de la tête d'impression.
- ◆ Please handle printer and paper handling with care not to be heated. Temperature setting. Allowance of being heated.
- ◆ Ne pas exposer directement l'imprimante aux courants d'air des appareils de ventilation ou de climatisation.
- ◆ Il est courant d'être peut affecter la projection d'encre, empêchant ainsi l'obtention d'une qualité d'impression satisfaisante, ou entraîner un dysfonctionnement de la tête d'impression, suite à l'assèchement de l'encre à l'intérieur des buses.
- ◆ Si vous n'utilisez pas l'imprimante pendant une longue période, effectuez un nettoyage normal une fois par semaine.
- ◆ Si vous ne nettoyez pas régulièrement, l'encre durcit à l'intérieur des buses et peut provoquer des problèmes de tête.
- ◆ Si vous ouvrez le couvercle avant l'impression, l'encre peut être projetée à l'intérieur de la tête d'impression, ce qui peut entraîner un dysfonctionnement de la tête d'impression.
- ◆ Si vous ne retirez pas le média et maintenez le couvercle ouvert pendant une longue période, l'encre peut être projetée à l'intérieur de la tête d'impression, ce qui peut entraîner un dysfonctionnement de la tête d'impression.
- ◆ Please handle printer and paper handling with care not to be heated. Temperature setting. Allowance of being heated.
- ◆ Ne pas exposer directement l'imprimante aux courants d'air des appareils de ventilation ou de climatisation.
- ◆ Il est courant d'être peut affecter la projection d'encre, empêchant ainsi l'obtention d'une qualité d'impression satisfaisante, ou entraîner un dysfonctionnement de la tête d'impression, suite à l'assèchement de l'encre à l'intérieur des buses.
- ◆ Si vous n'utilisez pas l'imprimante pendant une longue période, effectuez un nettoyage normal une fois par semaine.
- ◆ Si vous ne nettoyez pas régulièrement, l'encre durcit à l'intérieur des buses et peut provoquer des problèmes de tête.
- ◆ Si vous ouvrez le couvercle avant l'impression, l'encre peut être projetée à l'intérieur de la tête d'impression, ce qui peut entraîner un dysfonctionnement de la tête d'impression.
- ◆ Si vous ne retirez pas le média et maintenez le couvercle ouvert pendant une longue période, l'encre peut être projetée à l'intérieur de la tête d'impression, ce qui peut entraîner un dysfonctionnement de la tête d'impression.
- ◆ Please handle printer and paper handling with care not to be heated. Temperature setting. Allowance of being heated.
- ◆ Ne pas exposer directement l'imprimante aux courants d'air des appareils de ventilation ou de climatisation.
- ◆ Il est courant d'être peut affecter la projection d'encre, empêchant ainsi l'obtention d'une qualité d'impression satisfaisante, ou entraîner un dysfonctionnement de la tête d'impression, suite à l'assèchement de l'encre à l'intérieur des buses.
- ◆ Si vous n'utilisez pas l'imprimante pendant une longue période, effectuez un nettoyage normal une fois par semaine.
- ◆ Si vous ne nettoyez pas régulièrement, l'encre durcit à l'intérieur des buses et peut provoquer des problèmes de tête.
- ◆ Si vous ouvrez le couvercle avant l'impression, l'encre peut être projetée à l'intérieur de la tête d'impression, ce qui peut entraîner un dysfonctionnement de la tête d'impression.
- ◆ Si vous ne retirez pas le média et maintenez le couvercle ouvert pendant une longue période, l'encre peut être projetée à l'intérieur de la tête d'impression, ce qui peut entraîner un dysfonctionnement de la tête d'impression.
- ◆ Please handle printer and paper handling with care not to be heated. Temperature setting. Allowance of being heated.
- ◆ Ne pas exposer directement l'imprimante aux courants d'air des appareils de ventilation ou de climatisation.
- ◆ Il est courant d'être peut affecter la projection d'encre, empêchant ainsi l'obtention d'une qualité d'impression satisfaisante, ou entraîner un dysfonctionnement de la tête d'impression, suite à l'assèchement de l'encre à l'intérieur des buses.
- ◆ Si vous n'utilisez pas l'imprimante pendant une longue période, effectuez un nettoyage normal une fois par semaine.
- ◆ Si vous ne nettoyez pas régulièrement, l'encre durcit à l'intérieur des buses et peut provoquer des problèmes de tête.
- ◆ Si vous ouvrez le couvercle avant l'impression, l'encre peut être projetée à l'intérieur de la tête d'impression, ce qui peut entraîner un dysfonctionnement de la tête d'impression.
- ◆ Si vous ne retirez pas le média et maintenez le couvercle ouvert pendant une longue période, l'encre peut être projetée à l'intérieur de la tête d'impression, ce qui peut entraîner un dysfonctionnement de la tête d'impression.
- ◆ Please handle printer and paper handling with care not to be heated. Temperature setting. Allowance of being heated.
- ◆ Ne pas exposer directement l'imprimante aux courants d'air des appareils de ventilation ou de climatisation.
- ◆ Il est courant d'être peut affecter la projection d'encre, empêchant ainsi l'obtention d'une qualité d'impression satisfaisante, ou entraîner un dysfonctionnement de la tête d'impression, suite à l'assèchement de l'encre à l'intérieur des buses.
- ◆ Si vous n'utilisez pas l'imprimante pendant une longue période, effectuez un nettoyage normal une fois par semaine.
- ◆ Si vous ne nettoyez pas régulièrement, l'encre durcit à l'intérieur des buses et peut provoquer des problèmes de tête.
- ◆ Si vous ouvrez le couvercle avant l'impression, l'encre peut être projetée à l'intérieur de la tête d'impression, ce qui peut entraîner un dysfonctionnement de la tête d'impression.
- ◆ Si vous ne retirez pas le média et maintenez le couvercle ouvert pendant une longue période, l'encre peut être projetée à l'intérieur de la tête d'impression, ce qui peut entraîner un dysfonctionnement de la tête d'impression.
- ◆ Please handle printer and paper handling with care not to be heated. Temperature setting. Allowance of being heated.
- ◆ Ne pas exposer directement l'imprimante aux courants d'air des appareils de ventilation ou de climatisation.
- ◆ Il est courant d'être peut affecter la projection d'encre, empêchant ainsi l'obtention d'une qualité d'impression satisfaisante, ou entraîner un dysfonctionnement de la tête d'impression, suite à l'assèchement de l'encre à l'intérieur des buses.
- ◆ Si vous n'utilisez pas l'imprimante pendant une longue période, effectuez un nettoyage normal une fois par semaine.
- ◆ Si vous ne nettoyez pas régulièrement, l'encre durcit à l'intérieur des buses et peut provoquer des problèmes de tête.
- ◆ Si vous ouvrez le couvercle avant l'impression, l'encre peut être projetée à l'intérieur de la tête d'impression, ce qui peut entraîner un dysfonctionnement de la tête d'impression.
- ◆ Si vous ne retirez pas le média et maintenez le couvercle ouvert pendant une longue période, l'encre peut être projetée à l'intérieur de la tête d'impression, ce qui peut entraîner un dysfonctionnement de la tête d'impression.

Printer Safe Handling Label



Hot Surface Caution Label

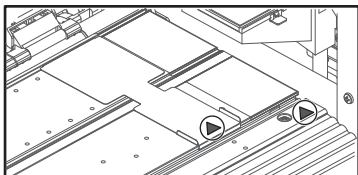

The surface may get hot and may cause burn injury. Do not touch with your hand for at least 30 minutes after turning off the printer.

CAUTION / ATTENTION / 注意

- ◆ Do not push the cutter cap. It may damage the part.
- ◆ Évitez de pousser le couvercle ou dispositif de coupe, au risque d'endommager la pièce.
- ◆ カッターキャップを押さないでください。カッターキャップが破損する場合があります。

Cutter Cap Caution Label

When replacing a cutter blade, do not push the cutter cap.

CAUTION / ATTENTION / 注意

- ◆ Do not bend or pull the waste ink drain tube. The ink may be leaked and damages the printer.
- ◆ Ne pas tirer ou plier le drain d'encre usagé; cela pourrait provoquer une fuite d'encre, et endommager l'imprimante.
- ◆ 廃液チューブを折り曲げたり、引っ張ったりしないでください。インクが漏れて製品が故障する恐れがあります。

Caution Label for Waste Ink Drain Tube Handling

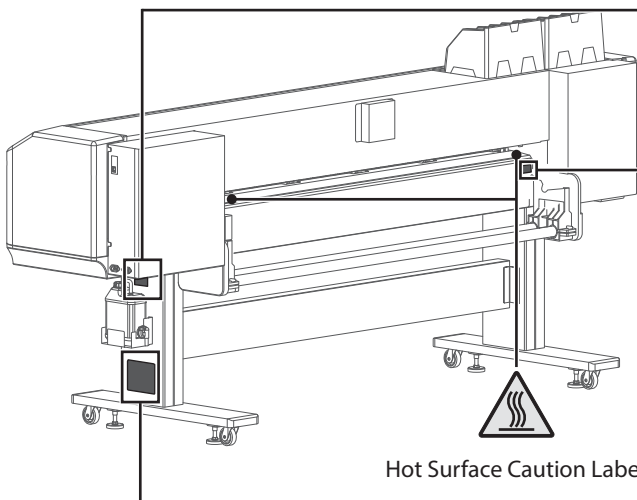

Hot Surface Caution Label

CAUTION / ATTENTION / 注意

Good No Good

- ◆ Do not touch the waste ink drain tube. It may cause damage to the part.
- ◆ Ne pas toucher le drain d'encre usagé. Cela pourrait provoquer des dommages à la pièce.
- ◆ 廃液チューブを触らないでください。部品が破損する恐れがあります。

Loading Position Caution Label

CAUTION / ATTENTION / 注意

Emergency Measures

Measures Urgence

注意喚起

Waste Fluid Caution Label

Note



Note

MUTOH