

V-2000HD-T

TABLE TOP SCREEN PRINTER

Features:

- 25 Year Warranty¹.
- Completely upgradeable - from 1 station - 1 color table top to 10 station - 10 color full rotary
- Quick release, never warp steel pallets with rubber tops.
- Gas lifters with 16 position variable lift strength.
- Embedded Registration bearings (close to the screen).
- Anti-backlash screen arm hinge bearings.
- 12" wide steel rear screen clamps.
- Heavy gauge all steel construction.
- Tool-less micro-registration (zero backlash) with 6-way print head leveling.
- Elevated pallets - no need to stretch shirts over the arm (ideal for youth shirts).
- Adjustable micro clamp knobs.
- Adjustable roller position lock bearings.

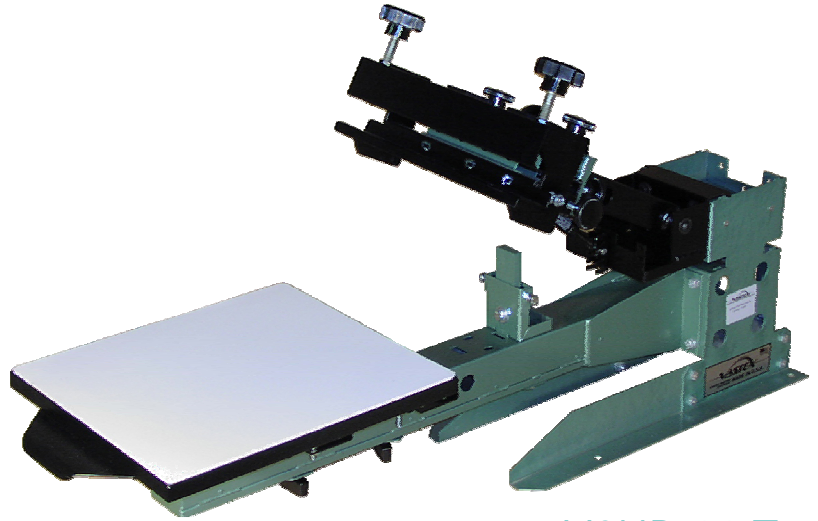

V2HD-11-T
1-station / 1-color

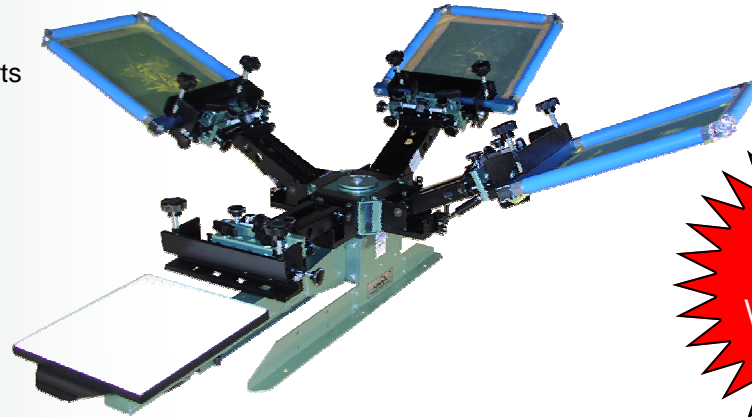

V2HD-14-T
1-station / 4-color



Options:

- Cap, jacket and **numbering attachments** available.
- Pallets: leg, short leg, sleeve, youth, mini, pocket, over-sized, vacuum and more.
- Table top stand (3 legs).
- Side clamps, removable or fixed.
- Add a second station for dual heads down.



VNM-12T-12
1-station / 2-color
with numbering attachment



Our Warranty Says It All!

1032 North Irving Street
Allentown, PA 18109-1846
USA

Phone: +1.610.434.6004
Toll Free: 1.800.482.7839
Fax: +1.610.434.6607

WWW.VASTEX.COM

Heavy Duty Precision Machines - Built To Last A Lifetime!

Did You Know?

With over 40+ years in the screen printing industry, Vastex has the knowledge and experience to build a printing system that is accurate, user friendly, affordable and built to last a lifetime!

As the pioneer in multi-color screen printing, we have more unique designs and features built-in to our presses than we could ever fully list here. And our quality is such that we warrant all our presses for 25 years¹! Vastex table top printers can be ordered with 1 or 2 stations and anywhere from 1 to 6 colors. Need to grow? No problem - you can easily add a stand for your table top or better still, upgrade it to a full rotary system!

From small things big things come - start your business right with a Vastex table top press and let it grow with you! To learn more, visit www.vastex.com.

Technical Specifications

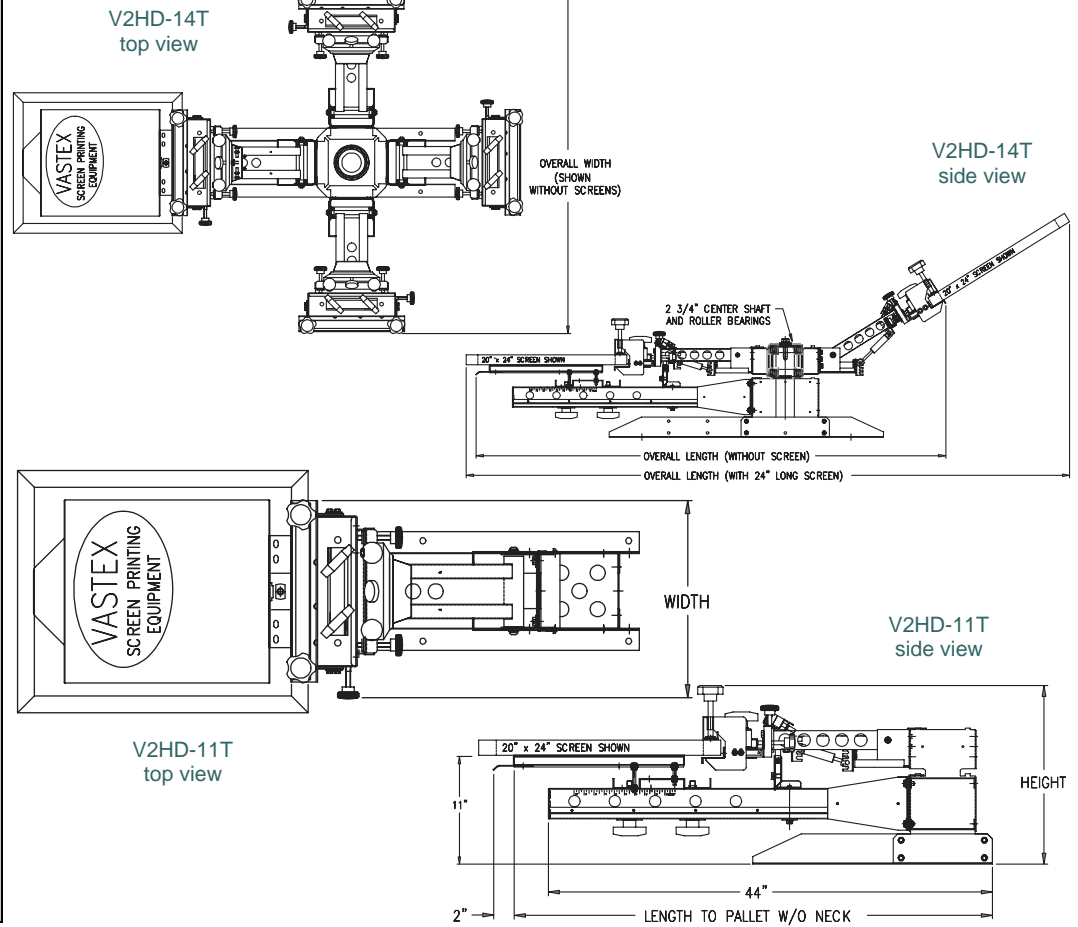

	V2HD-11T		V2HD-14T		V2HD-16T	
Width	17"	43 cm	49"	125 cm	55"	140 cm
Length	48"	122 cm	68"	173 cm	72"	183 cm
Max Screen Width	unlimited	unlimited	39"	99 cm	27"	69 cm
w/ optional side clamps	24"	61 cm	24"	61	21"	53 cm
Standard Pallet Size	15" x 17"	38 x 43 cm	15" x 17"	38 x 43 cm	15" x 17"	38 x 43 cm
Max Pallet Available ²	20" x 24"	51 x 61 cm	20" x 24"	51 x 61 cm	20" x 24"	51 x 61 cm
Table Height	11"	28 cm	11"	28 cm	11"	28 cm
Unit Weight	90 lbs	41 kg	294 lbs	134 kg	310 lbs	141 kg
Shipping Weight	93 lbs ³	42 kg ³	329 lbs	150 kg	345 lbs	157 kg
Shipping Size	42"x18"x12"@61# 24"x18"x10"@32#	107 x 46 x 31 cm 61 x 46 x 26 cm	50" x 48" x 23"	127 x 122 x 59 cm	50" x 48" x 23"	127 x 122 x 59 cm
Fits Thru Doorway	Yes - 30"	Yes - 76 cm	Yes - 30"	Yes - 76 cm	Yes - 30"	Yes - 76 cm
Expandable	To 2 station / 8 color Table Top or Up to 10 station / 10 color full rotary		To 8 color Table Top or Up to 10 station / 10 color full rotary		Up to 10 station / 10 color full rotary	

- All Vastex print heads and pallet arms are compatible with all Vastex printers including tabletop and freestanding machines.
- ¹ 25 year limited warranty. Gas springs and rubber mats covered for 3 years. Visit www.vastex.com for specific terms and conditions.
- ² Maximum pallet kept in stock. Custom and larger size pallets are available.
- ³ 2 boxes, ships UPS



Toll Free: 1.800.482.7839