

MiSTER-T1

OPERATOR'S MANUAL



Automatic Pretreat Spray Machine

Safety Instructions

For Use By Qualified Personnel Only

**When using your machine,
basic precautions should always be followed,
including the following:**

Read all instructions.

Use the Mister T1 only for its intended use.

Mister-T1 has to be operated with a precoating liquid for fabrics for DTG printer. Cleaning MUST be done with distilled water only! Other liquids alcohol or solvent may damage pumps or other components of the machine. Damages caused by unauthorized liquids are excluded from the warranty.

Mister-T1 comes with 12 months warranty. This warranty includes the whole construction of the machine, mechanical parts, electronics, drawer with rails, casing, pumps, electronic valve and pipes. Consumption items such as stainless steel nozzles, seals and filters are excluded from the warranty.

The set-up and installation of the machine has to be done under supervision of an authorized person. The installation has to be done by 2 or more persons following the instructions of this manual.

Caution: The Plug has to be pulled out of the power outlet while maintenance.

Never pull cord to disconnect the power, grasp plug and pull to disconnect from power outlet.

Protect the power cord by keeping it away from hot surfaces. Do not allow objects to sit on top of the cord. This could cause damage to the cord and could become a fire hazard risk.

Do not operate machine with a damaged cord or if the equipment has been damaged. Do not disassemble or attempt to repair the machine to prevent risks to injury. Call or take it to a qualified service person for examination and repair. Incorrect assembly or repair could increase the risk of fire, electric shock, or injury to persons when the equipment is used.

Supervision is necessary for any machine being used by or near children. Do not leave equipment unattended while connected.

Care should be taken to arrange the cord so that it cannot be pulled or tripped over.

To reduce the likelihood of circuit overload, do not operate other high voltage equipment on the same circuit.

The machine should only be used by trained personal after reading and understanding of the manual.

Congratulations on your purchase of a Mister T1 Pretreat Machine!

In order to work professionally with the machine and start production, please make sure you read this manual carefully.

Reproduction of this manual requires written consent.

Errors and amendments of technical details excepted, all rights reserved.

We are not liable for any direct or indirect damages caused by the use of this product.

Table of Contents

Machine Parts Diagram	4
Specifications	5
Circuit Diagram.....	5
Installation	6
Operating Instructions	8
Pretreatment Guide	11
Trouble Shooting	14
Maintenance	15
Warranty Information	19

Machine Parts Diagram

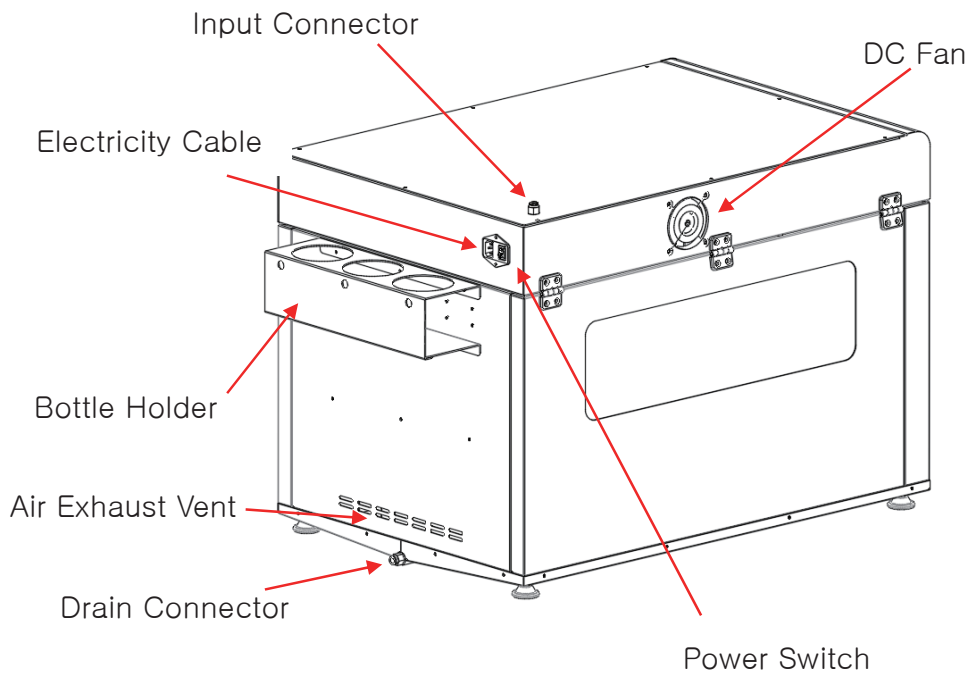
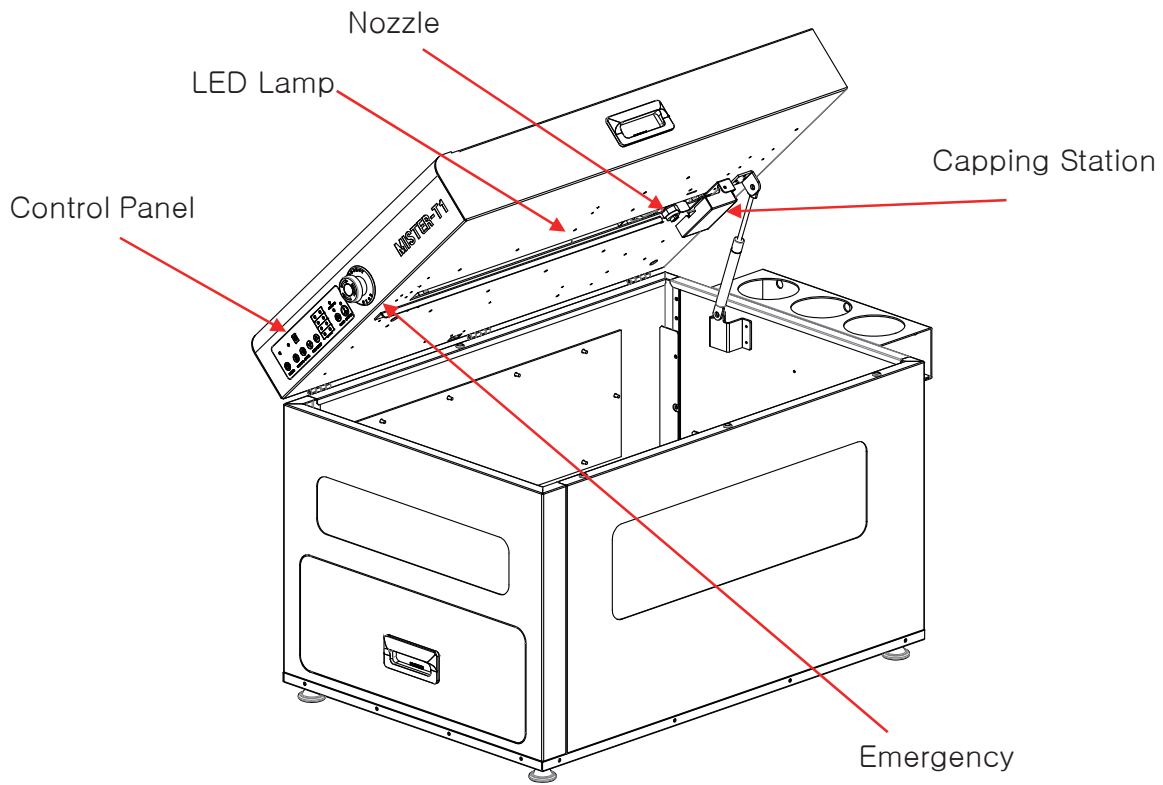

Mister-T1

Specifications

Dimensions	560mm(W) x 800mm(L) x 590mm(H)
Weight	35kgs
Platen Size	40cm x 50cm (16" x 20")
Number of Spray Nozzle	Single Nozzle
Maximum Spray Area	40cm x 50cm (16" x 20")
Spray Cycle Time	3 sec ~ 9 sec, by 1 to 5 speed
Power Supply	Free Voltage (100V~240V 50/60hz)
Power Consumption	60W
Packing Size	670mm(W) x 935mm(L) x 840mm(H)
Packing Weight	45Kgs
Liquid Consumption	With Minimum Speed : about 50ml With Maximum Speed : about 10ml

Circuit Diagram

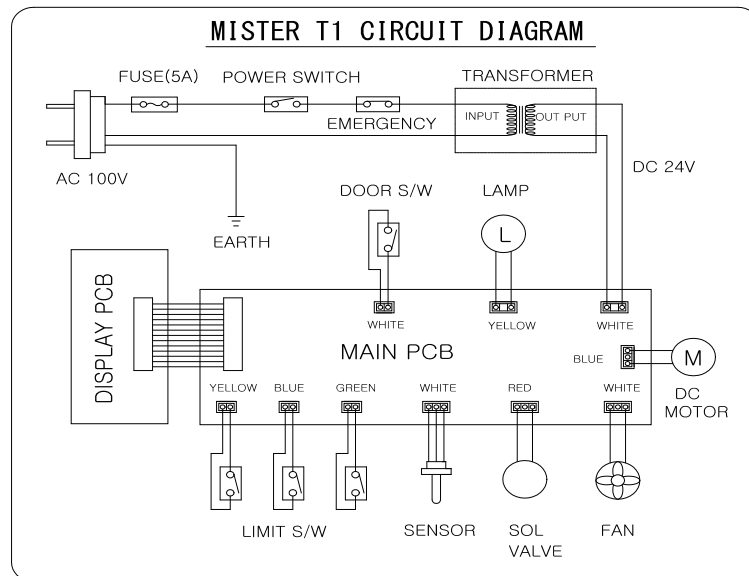

Installation

1. Machine Leveling:

Please ensure the machine is properly placed and leveled. Otherwise waste liquid in the machine can leak. To level the machine, turn the machine feet clockwise to decrease height and counter clockwise to increase height.



2. Assembly:

Bottle holder is located inside the machine. Gently open the top of the machine and find the bottle holder inside. Install the bottle holder on the back of the machine. There are 6 screws that attach the bottle holder.

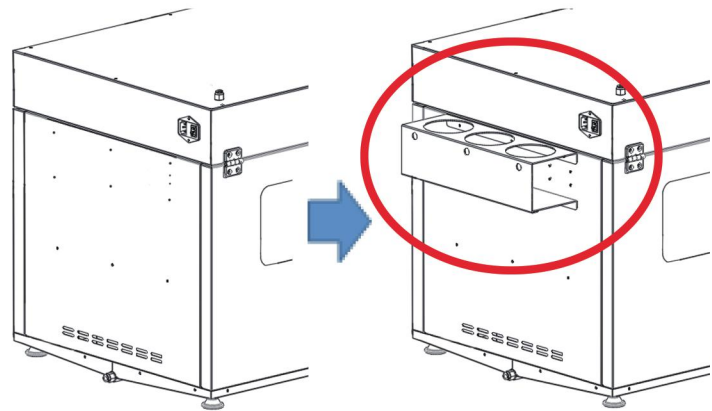

3. Connect the power cord.

The power switch and the power connection is located at the back of the machine.

4. Connect the waste liquid bottle and tube.

The drain is located at the back the machine on the bottom. Connect the large tube to the drain, and then place the other end in an empty bottle. This will collect any excess pretreatment when the machine sprays the shirt.

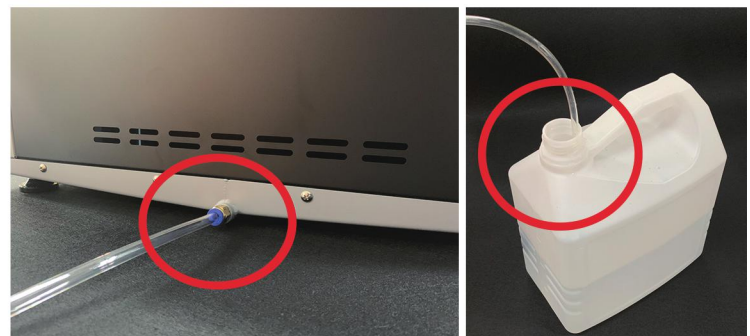

Installation (Continued)

5. Connect the small feed tube.

Step 1. Pass the end of the small tube through the hole of cap.

Step 2. Fully insert the end of the small tube into the feed connection of Mister-T1.

Step 3. Put the filter into the bottle.

When switching bottles, unscrew the cap and insert the tube and filter into the new bottle.

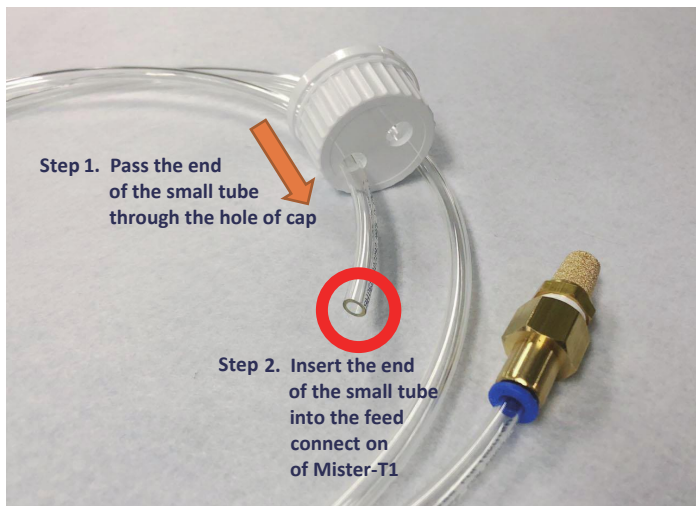

6. Fill a bottle with pretreat solution.

If using ECOFREEN UNIVERSAL concentrate, mix the liquid and purified water as below.



●	Universal 1L	+	Water 2L	=	<u>3L</u>	for DARK and BLENDED Garment
●	Universal 1L	+	Water 1L	=	<u>2L</u>	for 100% POLY
●	Universal 1L	+	Water 9L	=	<u>10L</u>	for BRIGHT Garment

7. Plug in the power cord into a power outlet.

Operating Instructions

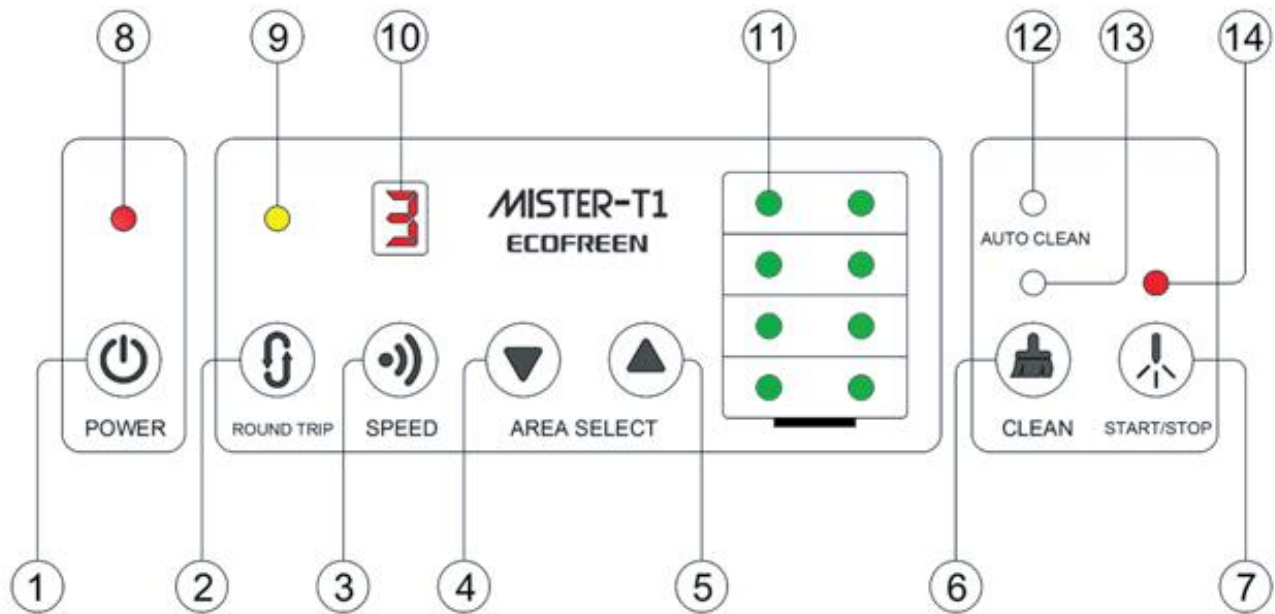

Understanding the Control Panel Menu

- 1) POWER ON/OFF BUTTON
- 2) ROUND TRIP BUTTON : Spray pre-coating liquid back and forth when lights are on.
- 3) SPEED BUTTON : 1~5 STEP (1: SPEED LOW / 5: SPEED HIGH)
- 4) AREA SELECT BUTTON :Selects spray area from top to bottom
- 5) AREA DESELECT BUTTON : Deselect spray area from bottom to top.
- 6) NOZZLE CLEANING BUTTON
- 7) START / STOP BUTTON : Spray pre-coating liquid / Stop spray
- 8) POWER LAMP
- 9) ROUND TRIP LAMP : Lights are on when ROUND TRIP mode is running
- 10) SPEED STEP LAMP (Display speed level when normal / Display "D" when door is opened / Display "E" when sensor malfunction)
- 11) AREA SELECT LAMP : Spray pre-coating liquid on area where the LAMP is on
- 12) AUTO CLEAN LAMP : Automatic spray for 1 second in every 4 hours when power is off
- 13) MANUAL CLEAN LAMP : Spray when light is on
- 14) START / STOP LAMP : Spraying when light is on

Operation

Operation

- 1) Turn on the POWER SWITCH on the back of the machine
Ensure the large red "STOP" button is not locked
If the "STOP" Button is locked, unlock by turning the button counter clockwise
- 2) Press the POWER BUTTON on the control panel to start the machine
(Press and hold for a few seconds)
- 3) Press ROUND TRIP BUTTON to control whether the machine does unidirectional spray or bidirectional.
When the round trip light is on, the machine will spray bidirectional.
If the button is off, the machine will spray unidirectional.
- 4) SELECT SPRAY SPEED : Change spray speed
Choose from 1 to 5 Speed level
Level 1 moves slowest to apply more liquid on the surface.
Level 5 moves the fastest to apply less liquid on the surface.
- 5) AREA SELECT BUTTON selects spray area
Spray area is divided into 4 sections and only sprays on the selected area
AREA SELECT BUTTON to select area from top to bottom and AREA DESELECT BUTTON to deselect area from bottom to top. For example, if you select speed level on 4 and select only center area to be sprayed

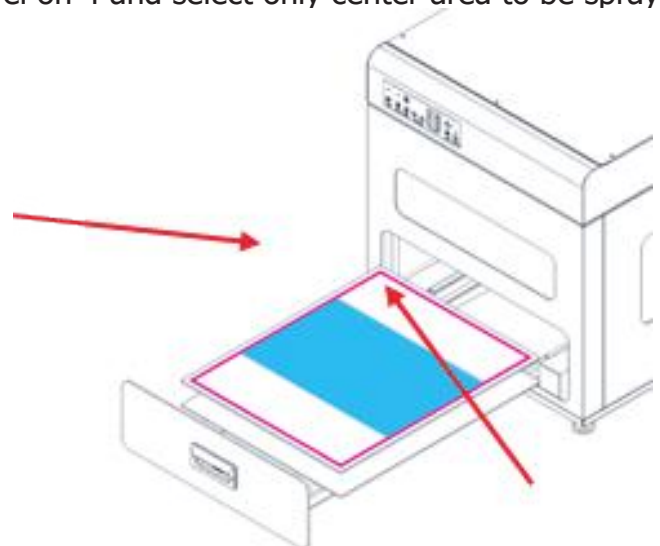

Operating Instructions

Operations Continued

6) BOTTLE SELECT

Switch the bottles by placing the small tube in the desired bottle. It is recommended to fill "bottle #3" with WATER (for cleaning the nozzle)

7) Cleaning

When you change the bottle to another (to different liquid), please press NOZZLE CLEANING BUTTON.



****WARNING****

IF YOU USE MULTIPLE COATING LIQUIDS, CHEMICAL REACTION MAY OCCUR WHICH CAN BE THE REASON FOR THE NOZZLE TO CLOG

Please clean the tubes and nozzle with water in bottle #3 in order to flush the tubes of the previous liquids before switching to another liquid. This will prevent any clogs that may occur due to chemical reactions between different pretreat liquids.

8) START/STOP.

Press the START BUTTON to start spraying your shirts with pretreat.
Also press button again to STOP if needed

Switching Pretreat Solutions

- When switching between pretreat solutions, switch to bottle #3 by placing the small tube in bottle #3 which should be filled with water for cleaning.
- Press the clean button. Let the machine spray until you see no pretreat solution in the tubes (7-10 secs). Once you see water in the tubes, press clean button again to stop the spraying/flushing.
- Switch from bottle #3 to the new bottle with pretreat solution. To do this, place the small tube in the new bottle. Press clean button to flush out the water (7-10 secs). Press clean button again to stop spraying/flushing once you see the tubes filled with pretreat solution.

Operating Conditions

Pretreating a Shirt

Use the Recommended Spray Volume and Fixation Temperature.

1. Please prepare all equipment to be turned on. Turn on the machine (red Switch at back and the front power button)
2. If pretreatment is already loaded in the tubes, skip steps 2 & 3. Press the clean button to ensure that the pretreatment solution is loaded into the tubes. This usually takes about 7-10 seconds.
3. Once you see the machine spraying the pretreat solution, press clean button again to stop the spraying
4. It is recommended to prepress your shirt on a heat press for 5 seconds to get rid of any wrinkles before spraying. Load your shirt. Tuck the sides of the shirts in the platen to avoid getting it caught in the railings.
5. Ensure you have set the appropriate speed and spray direction settings. The spray setting guide can be found on Page 12 and 13 of this manual. Press the start/stop button to start spraying once you have your shirt and settings set.
6. Place the pretreated shirt on the heat press to dry. Place a heat-resistant release sheet, such as Teflon/Silicon sheet between T-shirt and the heat press. Use the following settings to dry the shirt: The below settings are to be used as a guide. Some adjustment may be necessary.
 - BRIGHT COTTON : 320F~340F(160C~170C), 35~45 sec.
 - DARK COTTON: 320F~340F(160C~170C), 60~70 sec.
 - POLY : 320F~340F(160C~170C), 90 sec.





If the shirt is not dry after the recommended time, repress the shirt until dry.

● Pretreatment Note:





Different brands and types of shirts will require different amounts. Start with the recommended amounts on page 13 and adjust accordingly. Some testing may be required for new styles and brands of shirts. It is recommended to keep a record of how much is required for each brand/type of shirt.

DTG Pretreatment & Fixation Guidance

A. Heat Press Setting for Pretreatment

				
Garment	Bright Cotton	Dark Cotton	Poly	Blended (Hoodie)
Quantity	10-20g	20-35g	30g	50g
Speed Level on Mister-T1	Speed Level 5	Speed Level 4 or 5	Speed Level 4	Speed Level 1
Spraying Direction on Mister-T1	Uni-Direction	Bi-Direction	Bi-Direction	Bi-Direction
Time	35-45 seconds	60-70 seconds	90 seconds	90-120 seconds
Temperature	320-338°F (160-170°C)	320-338°F (160-170°C)	320°F (160°C)	320-338°F (160-170°C)
Pressure	1.0-2.0 Bars 14-29 PSI	7.0-8.0 Bars 101-116 PSI	7.0-8.0 Bars 101-116 PSI	7.0-8.0 Bars 101-116 PSI



B. Ink Heat Press Curing Setting

				
Time	45-55 seconds	90-100 seconds	90 seconds	90-120 seconds
Temperature	320-338°F (160-170°C)	320-338°F (160-170°C)	320°F (160°C)	320-338°F (160-170°C)
Pressure	1.0-2.0 Bars 14-29 PSI	0-1.0 Bars 0-14 PSI	0-1.0 Bars 0-14 PSI	0-1.0 Bars 0-14 PSI

Note) The above conditions subject to change depending on the fabric type. Please start with the recommended amounts of the liquid above and adjust accordingly.

C. Dilution Guide for Universal Liquid



	Universal 1L	+	Water 2L	=	<u>3L</u> for DARK and BLENDED Garment
	Universal 1L	+	Water 1L	=	<u>2L</u> for 100% POLY
	Universal 1L	+	Water 9L	=	<u>10L</u> for BRIGHT Garment

Pretreatment Guide

* SPEED CHART

SLOW << SPEED >> FAST
MORE << VOLUME >> LESS

1 2 3 4 5



Uni-Direction Spray

Light Color
Thick
26ml

Light Color
Thin
23ml

White
Thick
19ml

White
Medium
17ml

White
Thin
14ml



Bi-Direction Spray

Hoodies
52ml

Black
Super Thick
43ml

Black
Thick
36ml

Black
Medium
30ml

Black
Thin
25ml

The above are general guidelines on the speed and setting to use to pretreat your shirts.

Please note that some adjustments may be needed depending on the pretreat solution you use.

If shirts are not dry using the recommended heat press settings, please repress the shirt until it is completely dry before printing.

Not all shirts will be the same, so we highly recommend you do testing on any new shirts you pretreat before going into commercial production.

Trouble shooting

No.	Problem	Possible Reason	Solution
1	-Streaking on the shirts after coating -Irregular Spraying	- The nozzles are clogged - Filter is clogged	1. Clean the nozzle/filter (refer to maintenance) 2. Replace with new nozzle/ Filter
2	The pump generates no pressure or the spray is too weak	- Electronic valve, nozzle or filter is clogged. - The pump is dirty - The pump is faulty	1. Check the nozzle/filter for pollution and clean 2. Flush the pump with distilled water 3. Replace with new pump
3	Platen doesn't move	- Rails are sticky from pre-coating, dirty or worn out	1. Clean the rails. 2. Replace the rails.
4	The control panel doesn't respond to commands. No function possible	- The cover top is opened - A loose contact on the cable between the display and the electronics - Display failure	1. Please check the sensor located in the hinge of top. 2. Check the cable connection between electronics and the display. 3. Replace display 4. Turn the machine off and turn it on again
5	Power cannot be turned on	- Emergency button is on - Power cable is disconnected - Power switch behind of machine is turned off.	1. Please turn the emergency button off. 2. Please make sure the cables are connected. (Please don't touch with wet hands) 3. Turn on the power switch first.
6	Leaking	- Machine isn't well levelled	Please adjust of machine levelling. Recommended to place front side higher than the back.
7	Humidity inside	- Fan behind of machine stopped - Fan is defective	1. Please switch on the machine and let the fan run 2. Replace the fan
8	Waste liquid not draining	- Drain Connector is blocked - Drain tubes are bent	1. Check the drain connector 2. Drain tubes are to be positioned in lower place.

Maintenance

Cleaning The Nozzles

Step 1 - Press POWER ON/OFF BUTTON on the Control Panel to switch off

Step 2 - Open top cover



Step 3 - Turn the Nozzle Cap Nut to counter-clockwise to loosen and dislocate the nozzle

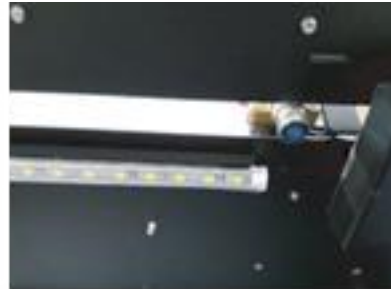

Step 4 - Clean the Nozzle Tip, Cap Nut and Sol VALVE using water and wet paper towel



Reference: The nozzle can be cleaned in an ultrasonic cleaner. To clean the nozzle and its parts, please fill distilled water and run it for 6-7 mins.

Storage

Never leave the nozzles exposed to air. Remaining precoat can be dried out and stick to nozzle. This will cause inconsistent spraying or clogging of the nozzle.



Maintenance (Continued)

Step 5 - Assemble the Nozzle Tip and the Nozzle Cap Nut as the picture on the right.

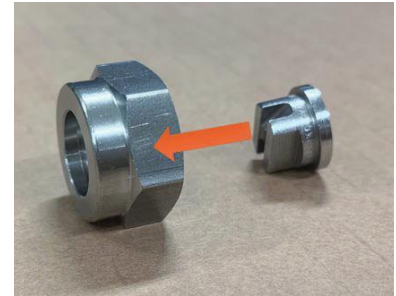

Caution: When Assembling Nozzle Tip
After disconnecting the nozzle and cleaning the nozzle,
Use Nozzle Assembly JIG to properly set the nozzle tip in
the correct position.

Failure to do this will result in the pretreat not being
sprayed properly on the shirt.

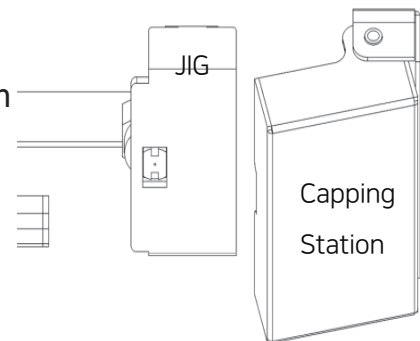

Filter Maintenance

Never leave the filter exposed to air. Doing so will cause the filter to clog.
The filter is a consumable part and will need to be replaced over time.

If your machine is not spraying liquid, check to see if the filter is clogged.
Simply remove the filter from the end of the tube and start spraying.
If spraying occurs after the filter is removed, then we can conclude filter is clogged
and will need to be replaced.

Maintenance (Continued)

Scan the QR CODE for the video !



DAILY MAINTENANCE

- ✓ Press "CLEAN" button to **flush with water and clean the nozzle everyday** at the end of work.
- ✓ **Never leave the filter exposed to air** to prevent filter from drying and clogging.

Always put the filter into the pretreat or cleaning water container.



MONTHLY MAINTENANCE

- ✓ Please replace the filter every two months.
Otherwise, filter will get clogged and unable to suck enough liquid, which causing inconsistent spraying.

[IMPORTANT NOTE]

Running the machine without filter will cause the damage of pump, solenoid valve, nozzle and inconsistent spraying.

The warranty will be void if the machine runs without placing the filter.

- ✓ Please replace the sponge in capping station every two months.
Otherwise, dried liquid on the sponge will cause the damage of nozzle and make it clogged.

! IMPORTANT

- ✓ Try to **keep the main power switch on**.

This will enable automatic cleaning program which is purging for seconds by every 4 hours when not in use.



Maintenance (Continued)

Self-Diagnosis : ENGINEERING MODE

1. How to Enter the Engineering Mode

Step 1. Turning on the power switch on the back of the machine

Step 2. Push "Clean" and "Start/Stop" button together while " - " appears on the control panel



2. Functional Check

When pushing each button on the control panel, designated part will be running for functional check
Please refer to the picture below for designated part

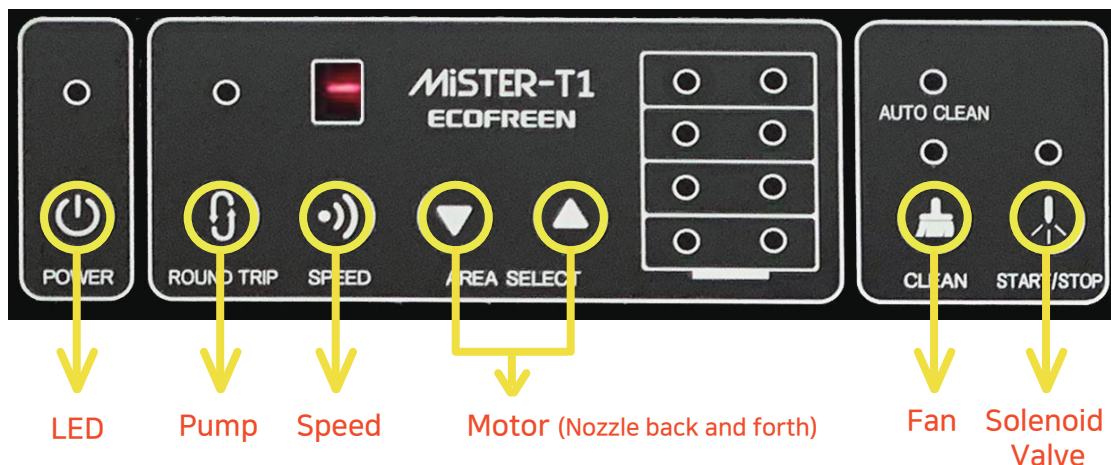

Warranty

Warranty Terms and Conditions

Mister-T1 has to be operated with a precoating liquid for fabrics for DTG printer. Cleaning **MUST** be done with distilled water only! Other liquids alcohol or solvent may damage pumps or other components of the machine. Damages caused by unauthorized liquids are excluded from the warranty.

Mister-T1 comes with **12 months** warranty. This warranty includes the whole construction of the machine, mechanical parts, electronics, drawer with rails, casing, pumps, electronic valve and pipes.

Consumption items such as stainless steel nozzles, seals and filters are excluded from the warranty.