

doc no. PSS-CDTF-06-22-01

PAT TECHNOLOGY SYSTEMS

# FILTRABOX



PREMIUM ENGINEERED FUME EXTRACTORS

## COMPACT<sup>X</sup><sub>DTF</sub>

PRODUCE QUALITY DTF TRANSFERS FOR GARMENTS AND OTHER  
SUBSTRATES IN A CLEAN AIR ENVIRONMENT

REINFORCED LIQUID FILTERS  
PROTECTED ELECTRONICS  
LARGE LIQUID RESERVOIR  
ULTRA-SLIM



[www.filtrabox.com](http://www.filtrabox.com)

# Specifications

## Compact X DTF

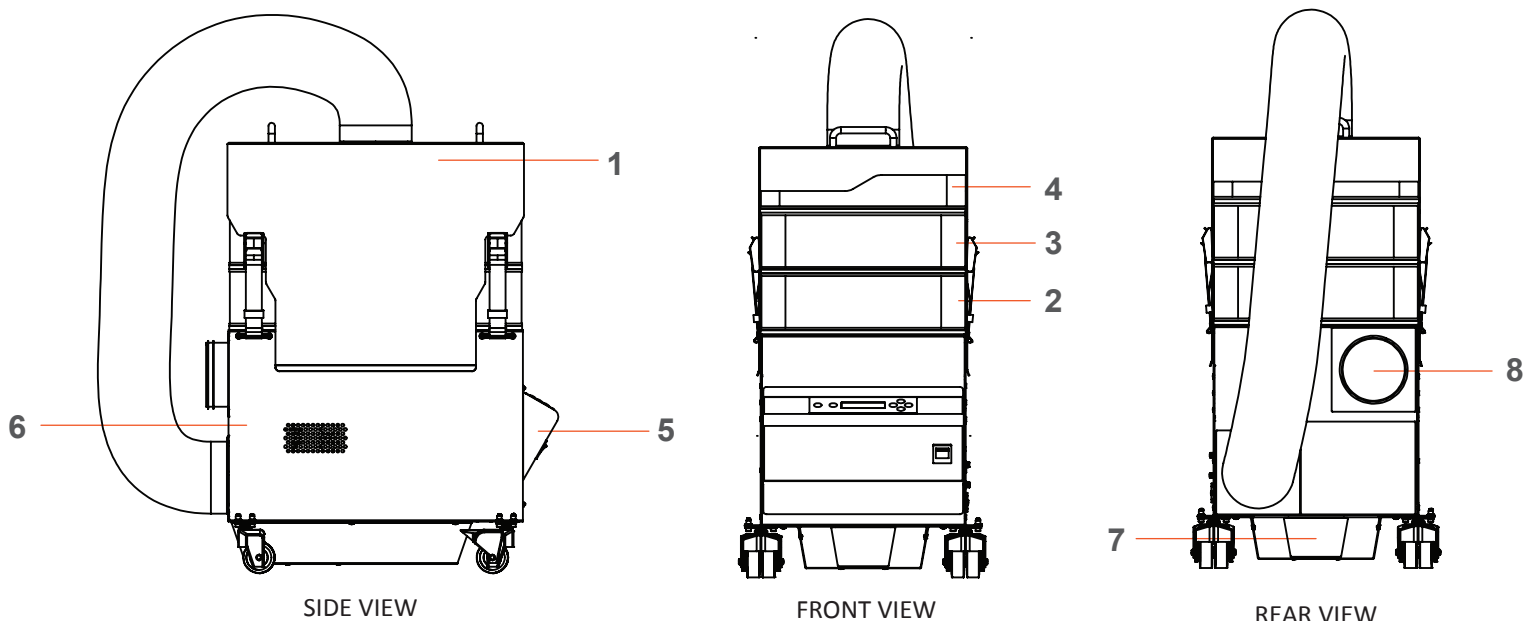

Technical Specification		
Quiet Operation	57 dB	
Max. Airflow	235 CFM	
Height	35 in.	
Width	15 in.	
Depth	29 in.	
Warranty	1 year	
Included Filters		
Type	Material	Total Media
1 Pre-filter	Synthetic Polymer	6 m <sup>2</sup>
1 HEPA	Hydrophobic Polymer	6 m <sup>2</sup>
1 Chemical Cartridge Filter	Coconut shell carbon	22 lbs.
Electrical		
Volts	230/120 V	
Frequency	50-60 Hz	
Rated Amps	6/12 A	

Contact us for details on hose kits.

### Legend

- 1) Lid Module
- 2) Rigid Aluminum Pre-Filter
- 3) Rigid Aluminum Hepa Filter
- 4) Oxy-Carbon Filter
- 5) Electronics Module
- 6) Blower Module/Liquid Reservoir
- 7) Exhaust Outlet
- 8) Inlet Spigot

Compact X DTF			USD
Compact X DTF	Compact X DTF	Compact X fume extractor w/ hose kit	\$4,295.00
Replacement filters			
Compact X Pre-Filter	FIL-P-CX-467	Synthetic Polymer	\$275.00
Compact X HEPA Filter	FIL-P-CX-457	Hydrophobic Polymer	\$350.00
Compact X Oxy-Carbon Filter	FIL-G-CX-447	Coconut shell carbon	\$425.00

For more information please call Filtrabox™  
 at +1 514-840-9696 (ext. 101)  
 or +1 877-582-7929 (International)