

MODEL: PLG-CUSTOM

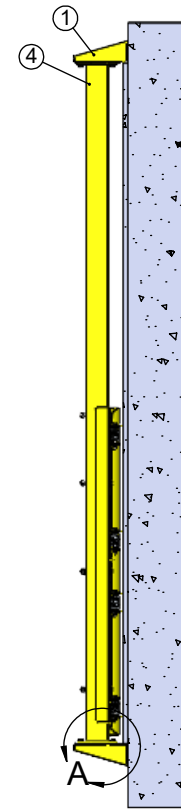

B.O.M. IS FOR QTY - 1				
ITEM NO.	PART NO.	DESCRIPTION	Qty	U/M
1	512385-10848301	PLG CUSTOM FACE MNT BRKT	2	EA
2	501947	WASHER;FLAT 3/8\"/>		
3	PLG-60-PCY	SAFEMEZZ PALLET GATE-PCY-60\"/>		
4	SPRTWELD-10848301	SUPPORT TUBE WELDMENT	2	EA
5	500400	BOLT;HEX3/8\"/>		
6	501118	NUT;NYLOCK 3/8\"/>		

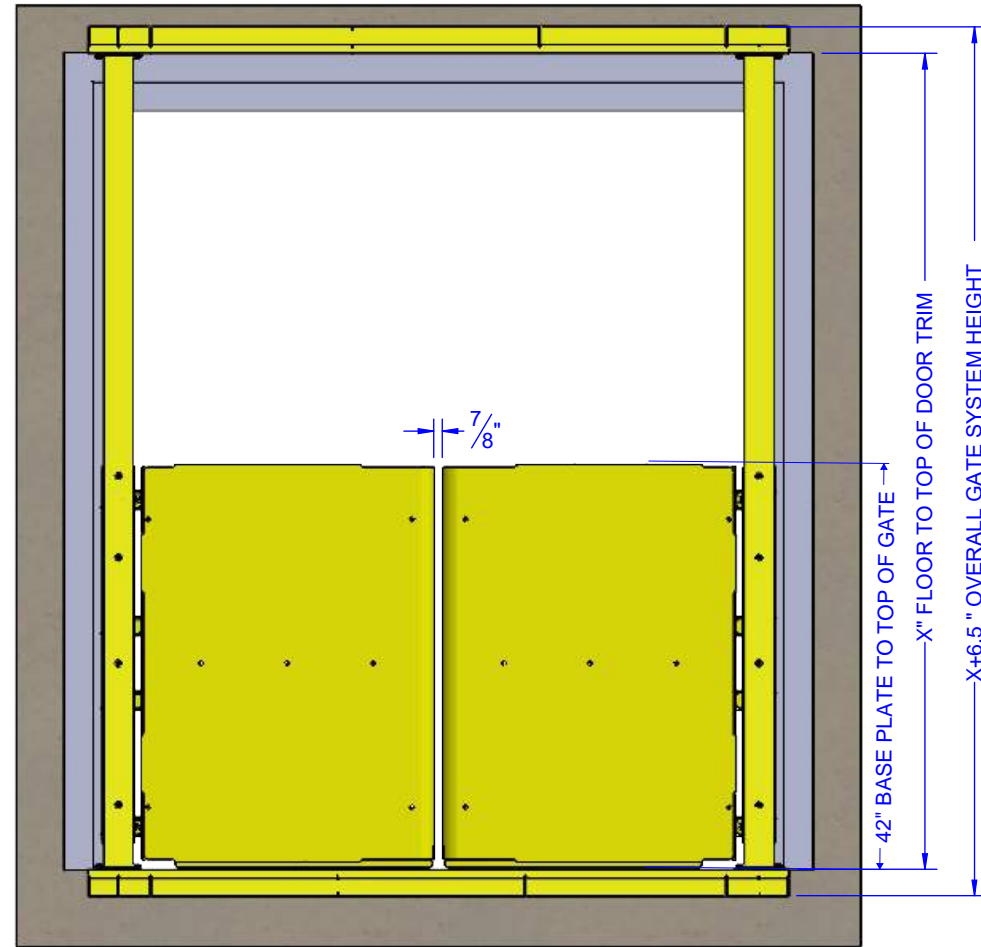
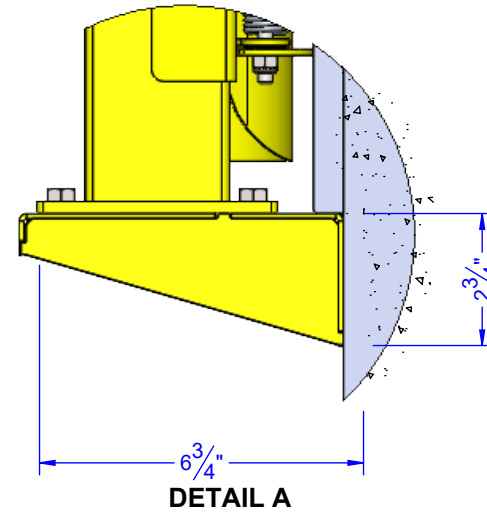
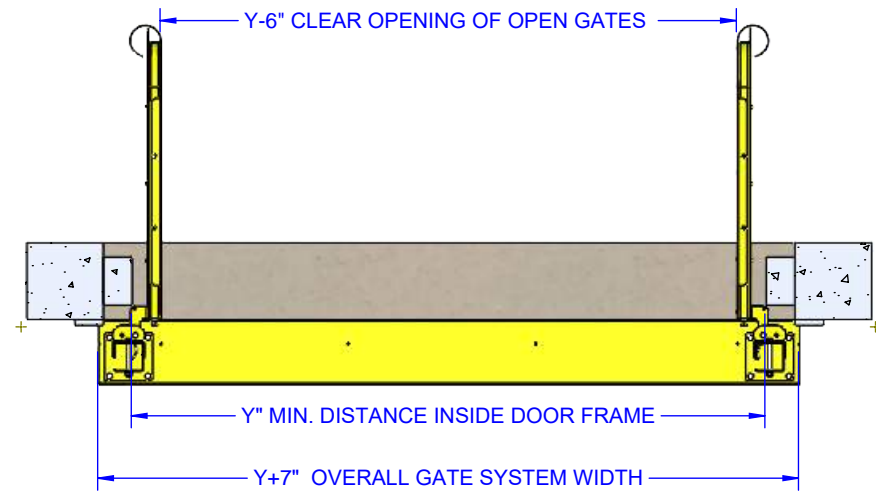
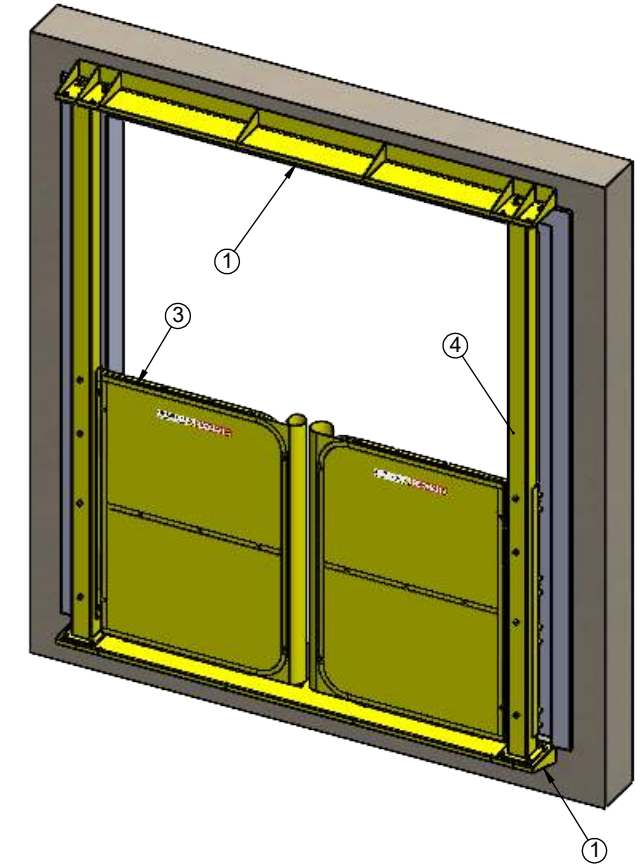

NO ANCHORS OR ANCHOR HOLES PROVIDED IN FRAME. DESIGN OF ANCHORAGE AND VERIFICATION OF EXISTING STRUCTURE'S ABILITY TO WITHSTAND ALL LOADS TRANSFERRED BY GATE IS BY OTHERS, NOT PS INDUSTRIES.

Measurements approved by:

Signature

Date

Print Name

C:\PS DOORS\PROJECTS\YELLOW PRODUCTS\PLG\AROUND DOOR FRAME MOUNT\410848302 - Design Files\4108483-001\GEN-10848301 - 1/20/2022

REV.	REVISIONS	DATE	REVISED BY	FINISH:	DOOR/OPENING NAME:	SN:	SO #:	QTY: 1
				SHERWIN WILLIAMS POLYESTER POWDER COAT TOP COAT COLOR - SAFETY YELLOW				
					SHIP TO:	DWG STATUS: APPROVAL DRAWING SUBMITTAL 1		DATE: 1/24/2022
					SOLD TO:	PROPRIETARY AND CONFIDENTIAL DRAWINGS ARE EXCLUSIVE PROPERTY OF PS INDUSTRIES INCORPORATED AND CANNOT BE USED IN WHOLE OR PART WITHOUT WRITTEN CONSENT © 2022 PS INDUSTRIES INCORPORATED ALL RIGHTS RESERVED		SCALE: NTS
					PROJECT NAME:	ESTIMATED PART/ASSY WEIGHT:		DWG BY: nlawonn
					CUST PO #:	DWG #:		CHECKED: /