CYCLEBOARD ELITE PRO

OWNER'S MANUAL

Important Instructions and Warnings

Read this manual completely before riding your CycleBoard.

CYCLEBOARD[™]
cycleboard.com PATENTED



TABLE OF CONTENTS:

Introduction	3
Cycleboard Major Parts And Diagram	4
Specifications	5
Folding / Unfolding Handle	6
Setup	7
Safety Instructions	8
Safety And Warning Labels	11
Operating Procedures	12
Throttle / LCD Display	15
Braking	19
Steering	20
Pre-ride Checklist	21
Battery And Charger Use And Care	23
Maintenance and General Troubleshooting	26
FAQ	30

Note: *Manual illustrations are for demonstration purposes only. Illustrations may not reflect exact appearance of actual product. Specifications are subject to change without notice.*

For assistance contact www.cycleboard.com

Please have your Serial Number ready before contacting CycleBoard for warranty assistance and/or replacement parts. It is located on the bottom of your CycleBoard.

INTRODUCTION

Congratulations on the purchase of your new CycleBoard!

Read this manual thoroughly! Pay special attention to the safety and product warnings before you start riding your CycleBoard to help ensure that you ride safely and your CycleBoard electric vehicle has a long service life.



READ AND UNDERSTAND THIS ENTIRE MANUAL BEFORE USING OR ALLOWING OTHERS TO USE THIS PRODUCT



UPDATES TO WARNINGS AND OWNERS MANUAL

We continually update our warnings, safety and product information on our website so please make sure to check it periodically at www.cycleboard.com

CYCLEBOARD ELITE PRO MAJOR PARTS AND DIAGRAM

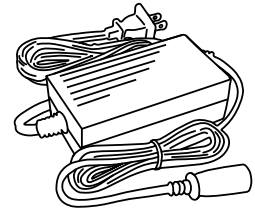
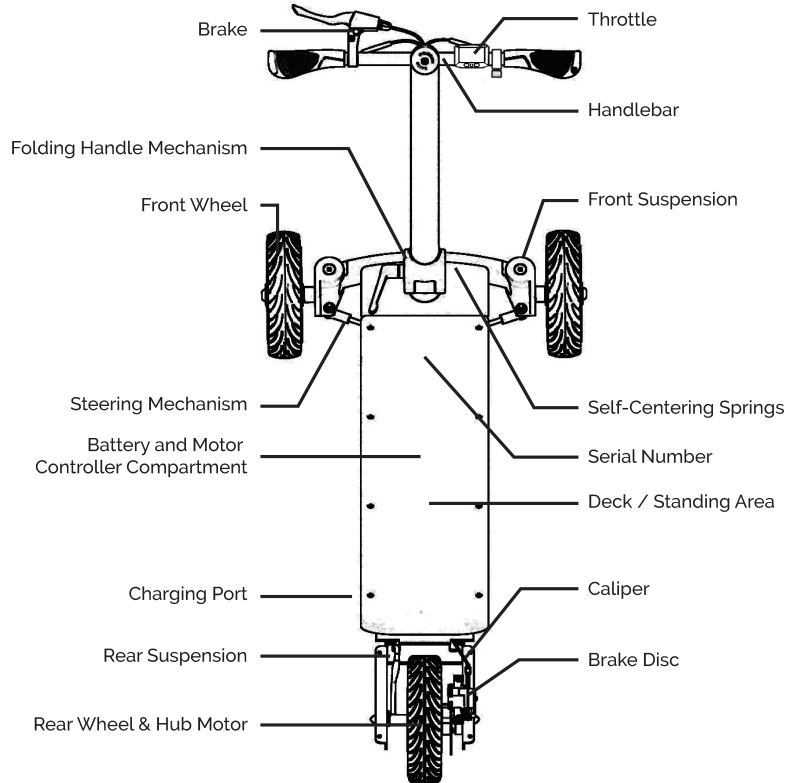

Battery Charger

SPECIFICATIONS

CYCLEBOARD

Weight: 48 lbs (without battery)
Max Capacity: 250 lbs
Max Speed: 25 MPH / 40 KMH
Full Charge Distance: Up to 25 Miles (12.8Ah Battery)
Climbing Grade: up to 25% Incline

MOTOR

48V 800W Silent Rear Hub Motor (1200w peak output)
Hall Sensors

BATTERY

Lithium Ion (LG Cells) – 48V 12.8Ah

CHARGER

2A charger – Input Voltage: 110 – 240V
Charging time: 12.8Ah battery = 5.5 hours Plug charger into wall outlet and CycleBoard charging port
Upgrade to the 3a charger and reduce charging time by 35%

BRAKES

Hydraulic brake + Electronic Brake + Parking Brake

TIRES

Front pneumatic. Rear semi-pneumatic



WARNING: DO NOT USE NON-CYCLEBOARD PARTS WITH YOUR CYCLEBOARD ELECTRIC VEHICLE. The vehicle has been built to certain design specifications. Certain aftermarket parts may or may not be compatible and may void your warranty.

***Note:** The CycleBoard must be moving at 2-3 mph while applying the throttle to engage motor.*

Need Help? Visit our website for replacement parts and product support at www.cycleboard.com

Make sure to register your CycleBoard on our website for access to replacement parts and to activate your warranty. The serial number is located on the underside of your CycleBoard.

FOLDING / UNFOLDING HANDLE

The CycleBoard comes with the handle folded down in the shipping box.

TO UNFOLD:

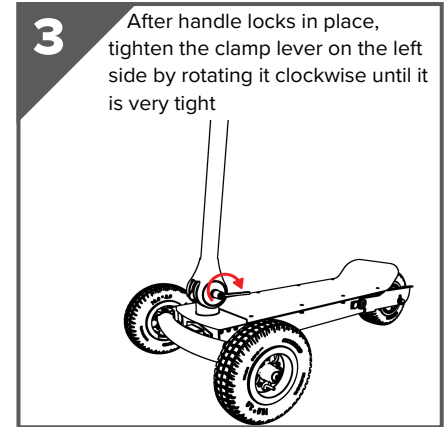
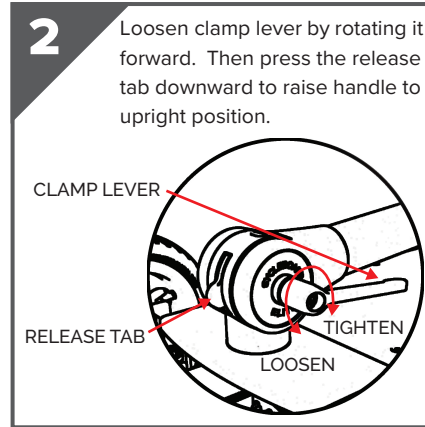
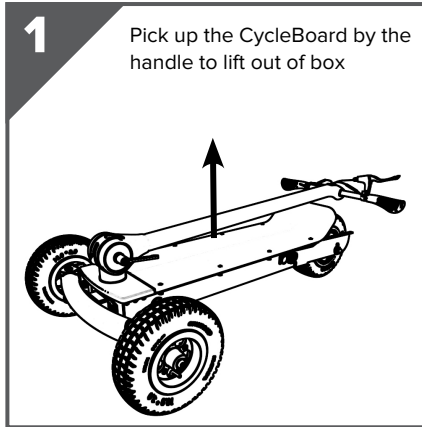

TO FOLD:

Reverse the steps above:

1. Loosen the clamp lever by rotating it forward.
2. Press the release tab downward.
3. Lower the handle until it locks in the down position
4. Once the handle locks in the down position, tighten the clamp lever by rotating it backwards

Note: If the release tab is difficult to press, gently shift the handle forwards and backwards while pressing the release tab.

Note: The "Clamp Lever" is SPRING LOADED to allow the user to position the lever to their desired location. To rotate the clamp lever forward or backward WITHOUT tightening or loosening it, Pull the clamp lever to the left away from the base of the handle to engage the spring and disengage the teeth

SETUP

PACKAGE CONTENTS:

- CycleBoard Electric Vehicle
- Battery Charger
- 2 Allen wrenches
- Quick Start Guide
- 4 Finger Nuts (for hinging deck)

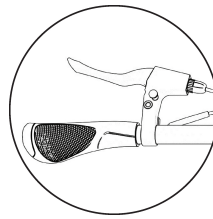

FIG 1. HAND BRAKE LEVER

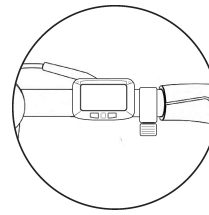

FIG 2. THROTTLE

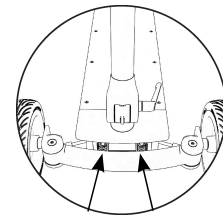

FIG 3. SPRINGS

INSTRUCTIONS:

Your CycleBoard has been pre-assembled and only requires a few steps to prepare it to ride:

1. After opening the box, inspect the contents for any damage that may have occurred during shipping. If anything has been damaged, contact us for replacement or repair.
2. The Hand brake lever and throttle (**Fig 1** and **Fig 2**) are adjusted downward for shipping. Adjust the throttle and hand brake lever to your desired location, then tighten the screws using the included Allen wrenches.
3. Fully charge your battery before riding for the first time. The light on your charger will change from red to green when the battery is fully charged.
4. Check the hand brake on the left handlebar to ensure it is functioning properly.
5. The self centering springs in the front of the CycleBoard may initially make squeaking and clicking sounds when steering but will stop after a short break in period. Shown in **Fig 3**.

LCD Display Functions

1. Long press the right button (Power) to turn on/off Power to the display.
2. After the display is powered on, press the buttons in this sequence: left, right, left right to unlock the display each time it is powered on (this is the password function).
3. Quick press the left button to switch from forward to reverse.
4. Quick press the right button to adjust the speed mode.
5. Long press the left button to turn the head light on/off.

Note: Your CycleBoard is pre-set to Ride-Mode 1 (Fast). Change to Ride-Mode 0 (Slow) for slower acceleration and longer battery range

Note: Always wait 10 minutes after charging your battery before riding.

Note: Always wait 15 minutes after riding before re-charging your battery.

Note: Always unplug your battery charger after the battery has finished charging.

Note: Charge your battery at least once per month if not in use for best battery care.

SAFETY INSTRUCTIONS

BE SURE TO READ AND UNDERSTAND THE SAFETY AND OPERATIONS SECTIONS OF THIS MANUAL. FAILURE TO USE COMMON SENSE AND HEED ALL WARNINGS AND INSTRUCTIONS INCREASES RISK OF SERIOUS INJURY OR DEATH. USE WITH APPROPRIATE CAUTION AND SERIOUS ATTENTION TO SAFE OPERATION.

The CycleBoard should be maintained and repaired in accordance with the manufacturer's specifications, using only the manufacturer's authorized replacement parts, and should not be modified from the manufacturer's original design and configuration.

ACCEPTABLE RIDING PRACTICES AND CONDITIONS

Always check and obey any local laws or regulations, which may affect the locations where the CycleBoard may be used. Do not turn on or activate the throttle unless you are standing on the CycleBoard with both hands on the handlebars and in a safe, outdoor environment suitable for riding. The normal powered top speed of the CycleBoard will be approximately 25 mph/40km/h, which can be affected by conditions such as rider weight, inclines, tire inflation and battery charge level. Avoid excessive speeds that can be associated with downhill rides. Do not do "wheelies" or pull up on the handlebars when riding, as this could cause damage to the CycleBoard or injury to the rider. Do not touch the brakes or motor of your CycleBoard when in use or soon after riding as these parts can become very hot. Watch out for potential obstacles that could catch your wheel or force you to swerve suddenly or lose control. Be careful to avoid vehicles, pedestrians, skateboards, scooters, bikes, other moving obstacles, or animals who may enter your path, and respect the rights and property of others. The CycleBoard is intended for use on flat surfaces such as pavement or level ground. Wet, slick, bumpy, uneven or rough surfaces may impair traction and contribute to possible accidents. Do not ride in mud, snow, ice, puddles or water. Avoid sharp bumps, drainage grates, and sudden surface changes. Do not attempt to do stunts or tricks, it is not made to withstand abuse from misuse, such as jumping, curb grinding or any other type of stunts. Racing, stunt riding, or other extreme maneuvers enhance the risk of loss of control. Do not ride at night without adequate lighting and visibility. Never use near steps, large drop offs or swimming pools. Do not allow hands, feet, hair, body parts, clothing, or other articles or objects to come in contact with moving parts, wheels, or while the motor is running. Never hitch a ride or hold onto another vehicle while on the CycleBoard. Do not immerse the CycleBoard in water, as the electrical and drive components could be damaged by water or create other possibly unsafe conditions. Make sure all bolts and screws are tight before riding. **CHECK AND MAINTAIN SAFE CONDITIONS** before use.

SAFETY INSTRUCTIONS (CON'T)

PROPER RIDING ATTIRE

Always wear proper protective equipment, such as an approved safety helmet (with chin strap securely buckled). *A helmet may be legally required by local law or regulation in your area. A long-sleeved shirt, long pants, and gloves are recommended. Always keep shoelaces tied and out of the way of the wheels and drive system.

USING THE CHARGER

The charger supplied with the CycleBoard should be regularly examined for damage to the cord, plug, enclosure and other parts. In the event of such damage, the product must not be charged until the charger has been replaced with a CycleBoard approved battery charger. Use only with the recommended charger. Use caution when charging. The charger is not a toy. Charger should be operated by an adult. Do not operate charger near flammable materials, in high heat temperatures or in confined spaces. Unplug charger and disconnect from the CycleBoard when not in use. Do not exceed charging time. Always disconnect the charger and turn off the throttle prior to wiping down and cleaning your CycleBoard with a damp cloth.

Riding a CycleBoard electric vehicle does present potential risks and caution is required. Like any riding product, this product has inherent hazards associated with its use (for example, falling off or riding it into a hazardous situation). Like any riding product, the CycleBoard is intended to move and it is therefore, of course, possible to lose control or otherwise get into dangerous situations. All riders must recognize that if such things occur, a rider can be seriously injured or die, even when using safety equipment and other precautions. Any rider unable to stand and lean comfortably on the CycleBoard as well as operate the throttle and brake properly should not attempt to ride it. Keep the CycleBoard away from children under the age of 18 and remember that it is intended for use only by persons who are, at a minimum, completely comfortable and competent while operating the product. Persons with any mental or physical conditions that may make them susceptible to injury, impair their physical dexterity or mental capabilities to recognize, understand, and follow safety instructions and to be able to understand the hazards inherent in its use, should not ride the CycleBoard. Persons with heart conditions, head, back or neck ailments, problems with balance (or prior surgeries to these areas of the body), or pregnant women, are cautioned not to operate the CycleBoard. **DO NOT EXCEED THE WEIGHT LIMIT OF 250 lbs. (113.4 kg).** Rider weight does not necessarily mean a person's size is appropriate to fit or maintain control of the CycleBoard.

SAFETY

WARNING: RIDE AT YOUR OWN RISK AND USE COMMON SENSE.

To minimize risks, follow these safety precautions:

- Always observe traffic regulations and do not lend your CycleBoard to anyone who is unfamiliar with it.
- Always test your brakes prior to riding and remember the CycleBoard will not stop as quickly in wet or icy conditions
- Frequently check your front tire pressures to ensure they are properly inflated before riding. Low tire pressures can result in damage to the tires and reduce your range
- NEVER drink alcohol and ride your CycleBoard.
- Always wear a helmet and other safety gear while riding.
- While riding, be aware of your surroundings and obey local traffic laws.
- Never exceed the 250-lb. weight limit.
- Never let children under the age of 18 ride your CycleBoard. The CycleBoard can reach speeds of 25mph+. The CycleBoard is an adult product and not meant for use by children.
- Always check all screws and bolts to ensure they are tight and operating properly prior to riding.

Note: *If screws or bolts are removed, replaced or become loose: Add Loctite to secure them from coming loose while riding.*

- Always check the throttle to ensure it is operating properly prior to riding.
- Never step on or off the CycleBoard while it is in motion
- Do not turn off the power while riding
- Avoid braking abruptly, especially while turning or going down hill as this could cause the rear tire to skid and loss of control
- Avoid riding at excessive speeds beyond your comfort level
- Avoid riding at excessive speeds not appropriate for your terrain
- Avoid riding at excessive speeds down hill
- Do Not ride over bumps or transitions that are larger than 1 inch.
- Do Not wash or get any of the electronic components wet
- Do Not ride in the rain or in very cold weather

SAFETY AND WARNING LABELS

SAFETY WARNING

Ride at your own risk. Severe injury or death may result if you do not follow the manual or warning labels. Steering is achieved through leaning left or right, do not attempt to steer like a bicycle. Do not jerk or force the handle in any direction as damage or injury could occur. Only turn throttle power on if rider is standing on the CycleBoard and always turn power off BEFORE stepping off. This product has a powerful motor, always start in "Speed Mode 1" and accelerate gradually. This product moves when in use, exercise caution and common sense when riding. Do not put fingers, other body parts or objects in the steering area between the two front wheels. Avoid riding down hills steeper than a 10-degree grade and speeds greater than 5mph until you have mastered the steering function. Never ride at night without adequate lighting and visibility. Never let children under the age of 18 operate this product. This is a high-performance transportation device and is not a toy. Weight limit max is 250 lbs. Avoid braking abruptly at speeds above 5mph or when riding downhill as this may cause skidding and loss of control. Never attempt wheelies, jumps or any other stunts. Never step on or off while product is moving. Always check brake, throttle, tire pressure and steering for property operation before riding. Ensure all bolts and screws are tight and operating properly before riding. Always wear a helmet and other body protective gear when riding. Don't touch rear wheel or brake disc during or shortly after use. Never put body parts or object near rear wheel or brake when in motion.

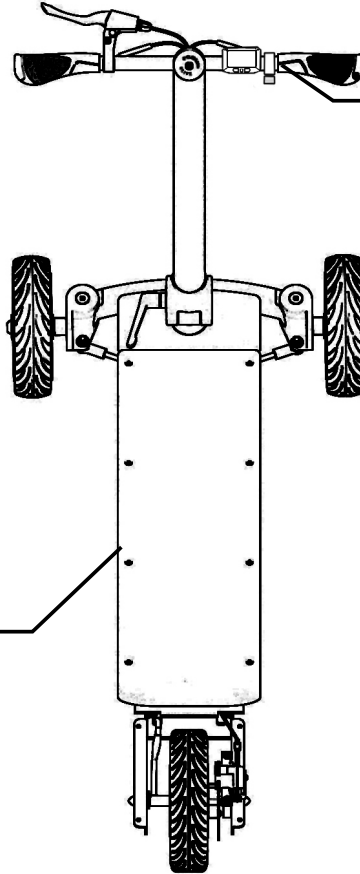

STOP:
Read the complete CycleBoard manual and all warning labels before attempting to operate this product.

OPERATING PROCEDURES

YOUR FIRST CYCLEBOARD RIDE: For your first CycleBoard ride, we recommend you go to an open area away from cars, pedestrians, cyclists, and potential hazards in order to practice and familiarize yourself with the CycleBoard controls and steering. Do this until you are able to safely operate your CycleBoard. Be sure to learn how to steer, adjust speed and brake before you attempt to ride in busy places.

STARTING YOUR CYCLEBOARD: Stand with both feet on the CycleBoard, push and hold the throttle power button until it turns on. ALWAYS start in Speed Mode 1. Keep one foot on the riding deck and push off on the ground with the other foot. The CycleBoard must be moving at 2-3 mph for the motor to engage. Slowly pull the throttle trigger to accelerate while keeping both hands on the handlebars. Do Not accelerate past Speed Mode 1 until you have mastered the steering and other functions of the CycleBoard.

STOPPING YOUR CYCLEBOARD : Release the throttle and apply the hand brake until the vehicle comes to a complete stop. Avoid braking too abruptly to prevent skidding.

AGE 18+: Operation of this CycleBoard by children under the age of 18 increases the risk of severe injury or death. This product is intended for adult use only. The CycleBoard is NOT a Toy. NEVER permit children under age 18 to operate or ride your CycleBoard. Keep this product secure and away from unsupervised children under the age of 18.

Max Weight 250 LBS: Do NOT exceed the weight limit of 250 lbs (113 kg).

WARNING: RIDING YOUR CYCLEBOARD AROUND CARS, PEDESTRIANS, CYCLISTS OR POTENTIAL HAZARDS BEFORE YOU ARE ABLE TO SAFELY DO SO COULD RESULT IN SEVERE INJURY OR EVEN DEATH.

WARNING: NEVER TURN THE CYCLEBOARD POWER BUTTON ON UNTIL YOU ARE STANDING ON THE CYCLEBOARD WITH BOTH HANDS ON THE HANDLEBARS IN CASE OF UNINTENDED MOVEMENT OF YOUR CYCLEBOARD.

WARNING: RIDING THE CYCLEBOARD MAY BE A DANGEROUS ACTIVITY AND MAY RESULT IN SERIOUS INJURY OR DEATH, EVEN WHEN USED WITH PROPER SAFETY PRECAUTIONS.

OPERATING PROCEDURES (CON'T)

Always wear a helmet, shoes and proper protective gear when riding a CycleBoard.

To minimize risks, follow these SAFETY PRECAUTIONS:

USE COMMON SENSE in deciding when, where and how you ride your CycleBoard. There are inherent, unavoidable risks in operating any vehicle, bike or scooter, especially around other vehicles, people and everyday hazards.

YOUR SAFETY IS UP TO YOU when you are operating your CycleBoard. We only list some of the do's and don'ts here, it is not possible to list them all.

DO NOT RIDE A CYCLEBOARD IF YOU ARE NOT COMFORTABLE with the CYCLEBOARD or with the risks of when, where and how you are riding it. It takes physical skills, strength, balance and good judgment to safely operate a CYCLEBOARD.

DO NOT RIDE A CYCLEBOARD IN HAZARDOUS AREAS, off-road, or in weather or road conditions where you do not have adequate stability and control of your CYCLEBOARD. The CYCLEBOARD was designed for dry, relatively level and flat surfaces (like pavement), and is not designed for uneven, wet, muddy, icy or other surfaces. The CYCLEBOARD was not designed for steep hills, grades or ramps, or for jumps, large bumps, steps, drainage grates, stunts or racing.

DO NOT LET YOUR CELL PHONE OR HEADPHONES or anything else distract you from paying full attention to your operation of your CYCLEBOARD.

DO NOT RIDE in conditions where other vehicles, riders or people cannot see you or where you cannot see them.

DO NOT ride in the dark with no visibility, the CycleBoard does not have a headlight or brake light.

DO RIDE SAFELY. Drive defensively. Anticipate hazards. Be aware of the people, vehicles and objects around you.

DO HOLD ON TO THE HANDLEBARS with both hands at all times.

CONTROL YOUR SPEED, especially if you ride down an incline as your CYCLEBOARD can pick up speed.

DO COMPLY WITH ALL RULES AND LAWS APPLICABLE TO YOU and YOUR CYCLEBOARD. Rules and laws vary from locale to locale, from state to state and from country to country. It is your responsibility to know and follow those rules and laws, which are subject to change.

OPERATING PROCEDURES (CON'T)

OPTIMAL RIDING POSITIONS

The best way to ensure you are always well positioned during normal riding (and to minimize the risk of accidents), is to distribute your weight evenly between the rear and front wheels. To brake safely, shift your weight back toward the rear wheel while applying the hand brake. Avoid leaning too far over the handlebars - the rider must maintain balance on their feet, not leaning on the handlebars. The legs should be slightly bent to absorb impact, balance the body and ensure constant contact with the riding deck. Avoid skidding during braking, this may cause unsafe conditions and will prematurely wear out the rear tire.

PRACTICE SAFE RIDING

The handlebars **DO NOT TURN**. Avoid applying excessive force or making sudden jerking movements to the handlebars in any direction which can damage the lower handle area over time. Steering the CycleBoard is achieved through leaning from left to right.

DOWNHILL AND RIDER-ASSISTED RIDING

The CycleBoard is intended to be primarily powered by its electric motor and does not require the rider to manually operate it for successful riding. We recommend that you take time to familiarize yourself with the CycleBoard and to safely and gradually explore the limits of performance with each ride. This is especially important before attempting steep descents or speeds in excess of 10 mph. Riding downhill is advanced and requires you to be fully competent before even attempting it. Although the CycleBoard is designed to primarily be used with electrical power, the CycleBoard can also be ridden similar to a kick scooter.

THROTTLE / LCD DISPLAY

Read the instructions carefully before usage.

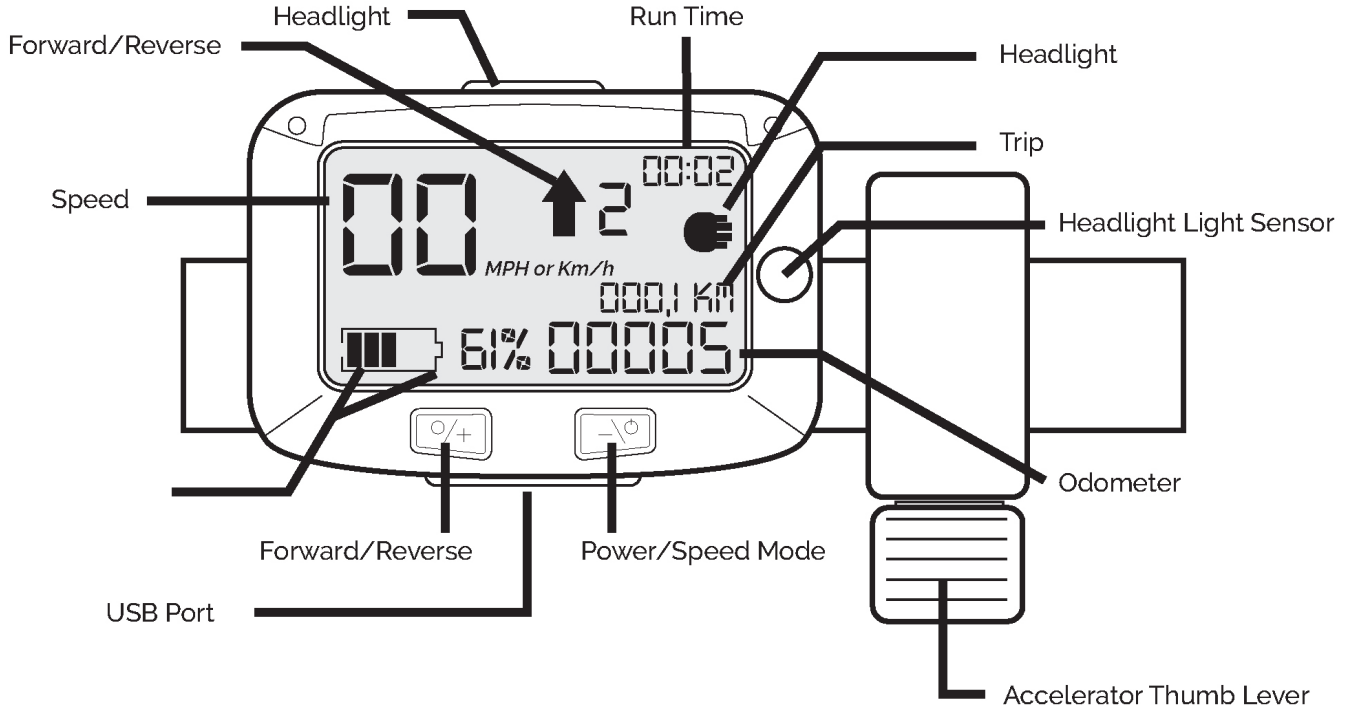

THROTTLE OPERATION

The CYCLEBOARD throttle is designed with advanced features like speed modes, safe-start, programmable speed limits and more.

To propel the CYCLEBOARD forward, keep one foot on the riding deck, push off on the ground with the other foot and push the throttle lever (located on the right handle) downwards, towards the ground. You are in control of the throttle and the further you push the throttle, the faster your CYCLEBOARD will go. The 5 speed modes allow you to manage your speed based on your skill level and the environment you are riding in. Each of the 5 speed modes has a top speed that limits how fast you can go in each speed mode. ALWAYS start in speed mode 1 when riding. To change the speed mode, press the up/down buttons on your throttle to increase/decrease your speed mode. Your CYCLEBOARD throttle also includes a “safe-start” feature that requires the CYCLEBOARD to be traveling at 2-3 mph before the motor will engage so you must push off the ground with one foot each time you want to start.

To slow down, simply let off of the throttle trigger. While your CYCLEBOARD will eventually stop by releasing the throttle, your CYCLEBOARD will stop faster by applying the hand brake on the left handlebar.

WARNING: WHEN YOU ARE NOT RIDING YOUR CYCLEBOARD, ALWAYS TURN THE POWER BUTTON OFF AND SECURE YOUR CYCLEBOARD TO PREVENT OTHERS FROM USING OR TAKING IT.

THROTTLE SETTINGS AND DEFAULT VALUES

THROTTLE USE AND FUNCTIONS:

Long press the right button (Power) to turn on/off Power to the display.

After the display is powered on, press the buttons in this sequence: left, right, left right to unlock the display.

Quick press the left button to switch from forward to reverse.

Quick press the right button to adjust the speed mode.

Long press the left button to turn the head light on/off.

ACCESS THROTTLE SETTINGS:

To enter and exit throttle settings, hold down both right and left buttons at the same time until the password interfaces appears.

Next, quick press the left, right, left, right buttons to unlock the settings interface.

Quick press the right button to move the cursor down.

Once at your selected item, long press the right and left buttons at the same time to change the “*” symbol to the “>” symbol, quick press the left button, press the right button to modify the value of your selected item.

Press and hold both buttons at the same time to lock in your changes.

Long press the right or left button to exit the throttle settings interface.

THROTTLE SETTINGS:

1: Run-Mode: Slow (0) Fast (1)

2: Start-Mode: Push to Start (1) *DO NOT modify this setting as it can create unsafe conditions.

3: Electronic Brake: On = Enabled, Off = Disabled 4: Speed-Max: Enter maximum speed limit

5: Clear-Mileage: Reset mileage

6: Language: English (EN) Chinese (CN)

7: MPH / Km/h: Select value

8: Password: On = Enabled, Off = Disabled

9: Throttle Auto Shutoff: Enter value

10: Factory Reset: Reset To turn on the CycleBoard

THROTTLE ERRORS AND SPEED MODES

ERROR DISPLAY

The error symbol  is displayed when there is an error fault.

ERROR CODES:

The corresponding figures represent the specific content of the fault state and are as follows:

- ERROR 0: Undervoltage Protection
- ERROR 1: Overvoltage Protection
- ERROR 2: Controller Malfunction
- ERROR 4: Communication Fault
- ERROR 5: Hall Sensor Malfunction
- ERROR 6: Throttle/Display Malfunction
- ERROR 7: Brake Malfunction

SPEED MODES

The CycleBoard throttle comes with 5 speed mode settings that limit top speed for safety.

Speed Mode	Top Speed
1	8 MPH / 13 KMH
2	13 MPH / 21 KMH
3	18 MPH / 29 KMH
4	22 MPH / 35 KMH
5	25 MPH / 40 KMH
Reverse	1 MPH / 2 KMH

To Increase Speed, press the right button to cycle through all 5 speed modes.

To select Reverse, push the left button and you will see the direction arrow change on the display.

SPEED-MAX

This setting allows you to decrease the top speed of the 5 speed modes by inputting a # less than 50. For example: an input of 40 will limit the top speed to 80% of the listed speed, an input of 30 will limit the top speed to 60% of the listed speed and so on.

BRAKING

Hydraulic Disc Brake + Electronic Brake: Your CYCLEBOARD is equipped with a hydraulic disc brake plus electronic braking for maximum reliability and stopping power. Applying hand pressure to the brake lever will cause the electronic braking to slow the motor and the further you pull the brake lever will cause the brake caliper to apply friction against the brake disc, slowing the rear wheel.

WARNING: STOPPING DISTANCES WILL VARY DEPENDING ON THE SPEED, WEIGHT OF THE RIDER, CONDITION OF YOUR TIRES, GROUND SURFACE YOU ARE RIDING ON AND YOUR BRAKE. ALWAYS ANALYZE THE CONDITIONS AND FAMILIARIZE YOURSELF WITH YOUR STOPPING DISTANCE BEFORE RIDING.

Avoid braking abruptly to minimize skidding and possible loss of control. Skidding is dangerous and will prematurely wear out your rear tire.

The CYCLEBOARD hand brake lever is equipped with a throttle cutoff feature that will dis-able the throttle when the brake is applied

WARNING: THE DISC BREAK WILL BE HOT AFTER RIDING. WAIT UNTIL THE BRAKE DISC HAS COOLED OFF BEFORE MAKING A BRAKE ADJUSTMENT OR BEFORE TOUCHING THE BRAKE DISC.

WARNING: DO NOT ATTEMPT TO ADJUST THE BRAKE DISC ITSELF WHERE IT ATTACHES TO THE REAR WHEEL UNLESS YOU ARE REPLACING A DAMAGED BRAKE DISC.

STEERING

The CycleBoard is a revolutionary stand up electric vehicle that uses an intuitive “Lean-to-Turn” steering design.

It **DOES NOT** steer like a traditional 2-wheel scooter or bicycle by turning the handlebars. The handlebars do not turn. Steering the CycleBoard is achieved by leaning your body from side to side (similar to a skateboard). This leaning motion will cause the riding deck and handle to pivot left or right as well as cause the wheels to steer in the direction you are leaning. The front wheels **turn** in the direction you are leaning and the rear wheel **leans** in the direction you are leaning.

DO NOT attempt to turn the handlebars while riding as this is not how the CycleBoard is designed to steer and may be dangerous. Start off by practicing in wide open areas on speed mode 1 and gradually increase your speed over time as your comfort and skill levels increase.

DO NOT exceed 10 mph or ride down hills until you have practiced riding the CycleBoard for at least 8 hours of cumulative riding time and have mastered the steering function.

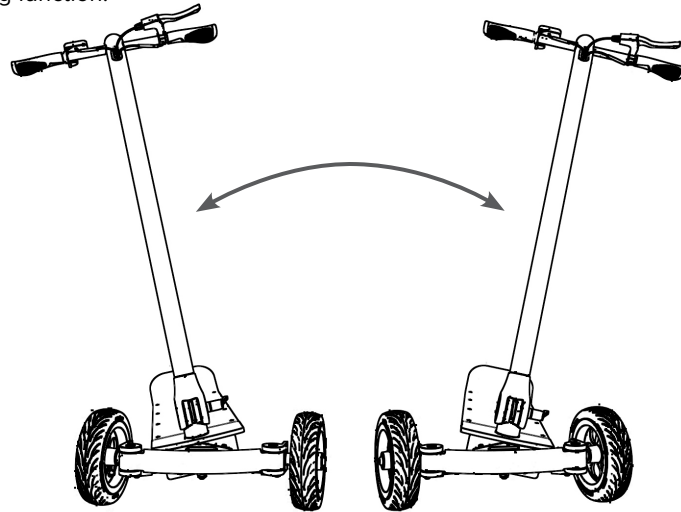

PRE-RIDE CHECKLIST

BEFORE RIDING, ALWAYS MAKE SURE TO THOROUGHLY CHECK YOUR CYCLEBOARD AND ENSURE IT IS SAFE TO OPERATE.

BRAKE

Check the brakes for proper function. When you squeeze the lever, the brake should provide positive braking action.

FRAME

Check for cracks or broken connections. Although cracked or broken frames are rare, it is possible for an aggressive rider to run into a curb or wall and wreck, bend or break a frame. Get into the habit of inspecting your CycleBoard on a regular basis.

WHEELS AND TIRES

Periodically inspect the tires for excess wear. Confirm front tires are inflated to 30-35 PSI for best battery range. Always check to ensure wheel bolts are tight. **Note:** *Front tires with uneven wear can cause dangerous conditions like speed wobble and should be replaced with new tires.*

STEERING

ALWAYS ensure the 4 underside bolts in the front steering mechanism are tight before riding. Add Loctite if they become loose.

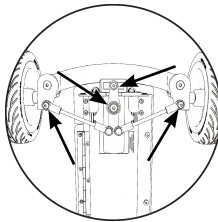

HARDWARE

Check all parts such as nuts, bolts, cables, fasteners, etc. to ensure they are secure and assembled correctly before riding. If the CycleBoard is damaged or not functioning properly, do not ride.

LAWS AND REGULATIONS

Always check and obey any local laws or regulations.

INSURANCE

Do not assume that your existing insurance policies necessarily provide coverage for use of this product. Check with your insurance company for information regarding insurance.

USAGE

Make sure you are physically and mentally ready and capable to ride your CycleBoard. This is a motorized three-wheeled product and riders must familiarize themselves with the characteristics

PRE-RIDE CHECKLIST (CON'T)

and proper use of the product. It is not “just like a bicycle,” it is not “just like a scooter,” and it is not “just like a tricycle.” The motor drives the rear wheel and riders must learn, practice and understand the proper use of this product to best, and safely, enjoy it. Particularly riders must learn and master the steering function of the CycleBoard, see more on this in the “Steering” Section of this guide.

RIDE AT YOUR OWN RISK AND USE COMMON SENSE

BATTERY AND CHARGER USE AND CARE

Included with your new CYCLEBOARD is a 48V lithium-ion battery and a 2amp lithium-ion battery charger. Your CYCLEBOARD battery is designed for high capacity charging and a long lifespan; however, improper use will damage the battery and decrease its charge strength and capacity.

RANGE:

- Up to 25 mile range on a full charge for the 12.8Ah Extended Range Battery

CHARGING TIMES:

- Up to 5.5 hours for the 12.8Ah Extended Range Battery

**Note: Actual range will vary based on things like; rider weight, speed, terrain, wind, hills, tire pressure, the amount of carving the rider does, etc.*

WARNING: IMPROPER USE, STORAGE, HANDLING OR DISPOSAL OF A BATTERY OR THE CHARGER CAN RESULT IN FIRE, ELECTROCUTION, SERIOUS INJURY OR EVEN DEATH.

WARNING: TO PREVENT THE CONNECTOR FROM SPARKING, PLUG THE CHARGER CONNECTOR INTO THE CHARGE PORT OF THE CYCLEBOARD (LOCATED AT THE LEFT SIDE OF THE CHASSIS FRAME) BEFORE PLUGGING THE CHARGER INTO AN OUTLET.

WARNING: TO REDUCE THE RISK OF IGNITION OR EXPLOSION, ALWAYS USE CHARGER WITH ADEQUATE VENTILATION AND IN NONCOMBUSTIBLE CONDITIONS.

WARNING: DO NOT DISABLE THE GROUND PRONG OR ANY OTHER PRONG ON YOUR THREE-PRONG PLUG. DOING SO INCREASES THE RISK OF ELECTROCUTION, FIRE AND PERSONAL INJURY OR DEATH. DO NOT MODIFY OR TAMPER WITH THE BATTERY CHARGER OR CHARGING PORT IN ANY WAY AND EVALUATE THEM BEFORE EACH USE FOR ANY POTENTIAL DAMAGE. IF YOU SEE ANY DAMAGE, DO NOT USE THE CHARGER OR PORT AND CONTACT CYCLEBOARD FOR REPAIR OR REPLACEMENT PARTS.

BATTERY AND CHARGER USE AND CARE (CON'T)

CHARGING YOUR CYCLEBOARD:

1. Turn the CYCLEBOARD off before charging or before conducting any maintenance or assembly procedures.
2. Plug one end of the charger into the charging port on the left side of the CYCLEBOARD frame.
3. Plug the other end of the charger into a standard 110V or 220V wall outlet. Check to confirm that the LED light on the charger lights up.
4. The LED light on the charger will turn from red to green once the CYCLEBOARD is fully charged.
5. Unplug the charger from the outlet and the charging port and do so promptly after charge is complete.

Note: Fully charge your CYCLEBOARD battery before the first use

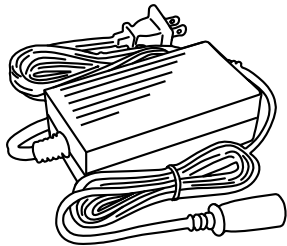

BATTERY CHARGER

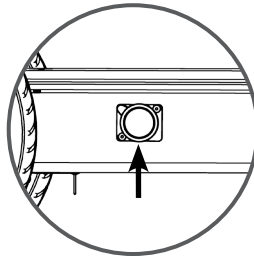

CHARGING PORT

Note: The CycleBoard battery charger is designed to work in 110 to 220 volt environments. You may need to purchase a plug adapter depending on the type of outlet used in your country.

WARNING: RECHARGEABLE BATTERIES ARE ONLY TO BE CHARGED UNDER ADULT SUPERVISION. ALWAYS DISCONNECT YOUR CYCLEBOARD FROM THE CHARGER BEFORE CLEANING WITH DAMP CLOTH. CHARGER MAY GET WARM DURING USE. THIS IS NORMAL FOR SOME CHARGERS AND IS NO CAUSE FOR CONCERN. IF YOUR CHARGER DOES NOT GET WARM DURING USE, IT DOES NOT MEAN THAT IT IS NOT WORKING PROPERLY.

BATTERY AND CHARGER MAINTENANCE

After much use, your battery's charge holding capacity will decrease.

However, if your battery does not hold sufficient charge even for a short trip, contact CYCLEBOARD to order a replacement. The charger supplied with your CYCLEBOARD should be regularly examined for damage to the cord, plug, and other parts. In the event of damage, do not charge the CYCLEBOARD until the charger has been repaired or replaced. If the charger emits unusual sounds or odors, immediately stop using it and contact CYCLEBOARD customer service.

- Make sure CYCLEBOARD power button is turned OFF when unit is not in use. If the power button is left on for an extended period of time, the battery may reach a stage at which it will no longer hold a charge.
- Use only the provided charger, as a lithium ion battery requires a specially designed charger. (Use of an unapproved charger could result in overheating or fire.)
- Unplug charger from wall outlet and disconnect from your CYCLEBOARD when not in use.
- Never store the CYCLEBOARD with the battery in a discharged state. (If you will not use your CYCLEBOARD for an extended period, charge it fully at least once per month)
- Recharge the battery before it becomes completely discharged. (When completely discharged, battery capacity will be reduced.)
- Store CYCLEBOARD in a cool, dry place.
- Electrical equipment may generate heat. Keep away from combustible materials.
- Do NOT leave CYCLEBOARD charging unattended.
- Do NOT store or subject the CYCLEBOARD, battery or charger to extremely high temperatures such as in direct sunlight, near a fire, or confined spaces without ventilation, etc.
- Do NOT store the CYCLEBOARD or charger in extremely low temperatures.
- Do NOT immerse the CYCLEBOARD or charger in water or other liquids.
- Do NOT place the CYCLEBOARD or charger near flammable or corrosive substances.
- The charger is NOT weather proof. Keep dry and away from water, other liquids and fire.
- Do NOT use the battery or charger to power devices other than your CYCLEBOARD.
- Do NOT exceed recommended charging time.
- Do NOT attempt to disassemble, repair or modify the battery or charger.

BATTERY AND CHARGER MAINTENANCE (CON'T)

- Do NOT put the CYCLEBOARD or battery in water, salt or acidic solutions.
- Follow proper battery disposal procedure: Recycle lithium-ion batteries. Do not throw away in regular trash or attempt to incinerate.

MAINTENANCE AND GENERAL TROUBLESHOOTING

WARNING: MAKE SURE THE CYCLEBOARD POWER BUTTON IS OFF BEFORE CHARGING OR BEFORE CONDUCTING ANY CLEANING, MAINTENANCE OR ASSEMBLY PROCEDURES.

CYCLEBOARD REPAIR AND MAINTENANCE:

Frequently check to make sure all the screws and bolts in your CYCLEBOARD are not loose, specifically the front and rear wheel bolts and the 4 bolts located on the underside of your CYCLEBOARD that are part of the steering mechanism. Add Loctite if they become loose.

Note: *This manual is not intended as a detailed service, repair or maintenance manual. Please seek assistance from a qualified technician for service, repairs or maintenance. Please visit our website www.cycleboard.com or email us at support@cycleboard.com for repair and maintenance information.*

CARE: You should periodically clean your CYCLEBOARD with a damp cloth to maintain the finish. Store your CYCLEBOARD out of direct sunlight and in a dry, cool environment to prevent unnecessary damage.

WARNING: YOU COULD BE SERIOUSLY INJURED OR EVEN KILLED IF YOU IMPROPERLY ATTEMPT OR MAKE REPAIRS.

MAINTENANCE AND GENERAL TROUBLESHOOTING (CON'T)

BATTERY CARE: Do not store in freezing or below freezing temperatures.

DISPOSAL: Your CYCLEBOARD product uses a Lithium-Ion battery which must be recycled or disposed of in an environmentally safe manner. Do not dispose of a Lithium-Ion battery in a fire. The battery may explode. Do not dispose of a Lithium-Ion battery in your regular household trash. The incineration, land filling or mixing of Lithium-Ion batteries with household trash is prohibited by law in most areas. Return exhausted batteries to a federal or state approved Lithium-Ion battery recycler.

CHARGER: The charger supplied with this CYCLEBOARD electric vehicle should be regularly examined for damage to the cord, plug, enclosure and other parts and in the event of such damage, the CYCLEBOARD must not be charged until the charger has been repaired or replaced. Use **ONLY** the charger supplied with this product or a recommended replacement specified by CYCLEBOARD.

WHEELS AND COMPONENTS: Wheels/tires, drive system and other components are subject to normal wear and tear. It is the responsibility of the user to periodically inspect the wheels/tires and other components for excess wear and adjust and replace components as necessary.

REPLACEMENT PARTS: For the complete selection of replacement parts visit www.cycleboard.com.

BATTERY CHARGER: The indicator light on the charger will turn green when plugged in to an outlet and the battery is fully charged. If the battery is not yet fully charged, the indicator light on the charger will be red indicating that it is still charging.

TROUBLESHOOTING GUIDE

PROBLEM	POSSIBLE CAUSE	SOLUTION
Throttle power won't turn on	Loose Throttle Connection	Check throttle connection
Charger not working, battery not charging	Not plugged in correctly Outlet not working Charger is damaged	Check outlet and charging port Try a different outlet Replace charger; Contact CycleBoard for assistance
Short run time, limited range	Rider weight Riding conditions Battery not fully charged Battery life has been reached Damaged Battery	Do not exceed 250lb weight limit Use only on flat, dry surfaces, avoid inclines and debris Fully recharge battery until light turns green on charger Replace battery - contact CycleBoard for assistance Replace battery - contact CycleBoard for assistance
Runs slow, power reduction	Battery not fully charged Rider weight Hills too steep	Fully recharge battery until light turns green on charger Do not exceed 250lb weight limit Use on flat surfaces
Handle won't fold/unfold	Handle release tab is stuck	Cover lower folding handle tab with thick cloth and lightly tap with a hammer to get tab unstuck
Handle is loose	Clamp lever at base of handle is loose	Tighten clamp lever by rotating it clockwise

TROUBLESHOOTING GUIDE (CON'T)

PROBLEM	POSSIBLE CAUSE	SOLUTION
Disc brake is rubbing	Brake caliper out of alignment Brake Disc is bent or damaged Worn out brake pads	Adjust brake caliper Replace brake disc; Contact CycleBoard for assistance Replace brake caliper; Contact CycleBoard for assistance
Brakes not working	Loose brake cable Brake caliper out of alignment Worn out brake pads	Adjust brake caliper Replace brake caliper; Contact CycleBoard for assistance
I'm getting speed wobble	Uneven tread wear on front tires Front tires inflated unevenly Front wheels out of alignment Rider weight unevenly distributed	Ensure front tires have equal tread and wear patterns Inflate front tires evenly Adjust steering rods so front wheels are perfectly parallel to the CycleBoard frame. Balance Rider Weight with one foot on front and one foot on back of board

FAQ

HOW LONG DOES IT TAKE TO FULLY CHARGE THE CYCLEBOARD BATTERY?

Approximately 5.5 hours if the CYCLEBOARD is completely discharged for the 12.8ah battery.

DO I NEED A LICENSE, INSURANCE OR REGISTRATION TO RIDE A CYCLEBOARD?

Typically not in the United States, but we encourage all riders in all countries to check with their local laws and insurance providers to verify they are following the law and meet their local requirements for riding.

HOW FAR CAN I RIDE ON A CYCLEBOARD ?

On a full charge, the CYCLEBOARD has a range of up to 25 miles for the standard 12.8ah battery. Traveling up steep inclines will take more energy out of the battery and is not recommended. Factors such as road surface, wind resistance and weight of the rider can also affect the CYCLEBOARD 's range.

WHAT SHOULD I DO IF MY TIRE(S) WEAR OUT?

Contact CYCLEBOARD for a replacement tire(s).

WHAT AREAS ARE APPROPRIATE FOR CYCLEBOARDING?

Bike lanes, sidewalks, trails and some streets are all great places to go CycleBoarding. (We recommend you check your local laws for any specific riding restrictions)

FAQ (CON'T)

HOW FAST CAN A CYCLEBOARD GO?

CYCLEBOARD's top speed is 25mph/40kph. Rider weight, inclines, declines and other factors can influence the speed and will cause your CYCLEBOARD to go faster or slower. We recommend NEVER exceeding 25mph which may occur going downhill.

HOW MUCH DOES A CYCLEBOARD WEIGH?

CYCLEBOARD weighs 52lbs without the battery.

IS THERE A WARRANTY ON MY PURCHASE?

CYCLEBOARD offers a 1 year limited warranty on all CYCLEBOARD'S purchased directly from CYCLEBOARD, LLC or from an authorized re-seller and a 6 month warranty on the battery. There is a summary of our warranty in this manual and you can also refer to our website at www.cycleboard.com for all warranty details.

HOW PORTABLE IS THE CYCLEBOARD ?

A. The CYCLEBOARD handle quickly collapses for easy storage and transportation and can fit in the trunk of most cars.

RECORD YOUR INFORMATION:

For your records, save your original sales receipt with this manual and write the serial number below. Your CYCLEBOARD model and serial number can be found on the underside of the frame

Serial Number: _____

Need Help? Visit our web site for replacement parts, product support and a list of authorized service centers at www.cycleboard.com

