



Crewsaver®

CREWTENDER

INFLATED AIR FLOOR TENDER BOAT RANGE

The Crewsaver range of air floor boats have been designed and developed to offer an affordable, high quality tender which is ideal for all round use, whether you are simply getting to your boat or getting out on the water for some fun.

The inflatable air floor creates a solid platform giving you greater stability and on water performance. All models are lightweight, compact and come complete with carry bag, pump, two piece paddles and repair kit.

These tenders can be easily rolled up for transporting or keeping stowed in a locker. It can also be fixed to stern davits by using the integral davit eyes and davit rings additional stainless steel rings on the outside of the bow help in towing and lashing down of the boat. These boats are built to last using high quality materials and the wide rubbing strake offers all round protection during those moments when coming alongside.

A wide range of traditional or electric out-board engines can fitted to the solid transom to give you a stylish and practical inflatable tender.

FEATURES

- **Compact**
- **Quick pressure relief valve**
- **Quick and easy to inflate and stow**
- **Thick rubbing strake around the boat**
- **2 x stainless steel tow rings fitted around the bow**
- **2 x stainless steel eye bolts fitted to transom for davit attachment**
- **Quick inflate/deflate valves**
- **Solid end cones for the protection**





WHAT IS INCLUDED

- Foot pump
- Repair kit
- 2x paddles
- Carry Valise (Bag)
- Mooring line
- Sliding alloy seat.

Air Floor Tender Boat Range comes in 3 size options

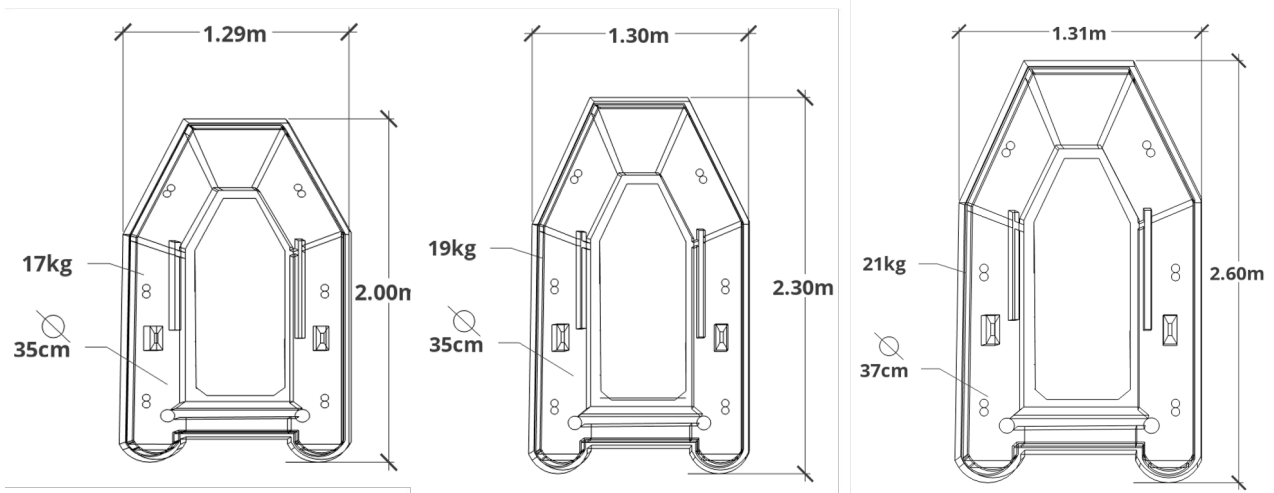

TECHNICAL DATA

Name / Part Code	CREWSAVER AIR 200 / 85050-200	CREWSAVER AIR 230 / 85050-230	CREWSAVER AIR 260 / 85050-260
Length	200	230	260
Width	129	130	131
Tube Diameter	35	35	37
Number of Persons	2	2	3
Max. Loaded Weight	250	350	400
Weight kg	17	19	21
Max HP	3.5	4	5.5
Packed Dimensions	80x40x45	80x40x50	80x40x50

Approvals
ISO approved

