

PARALLEL ARM INSTALLATION CLOSER MOUNTED ON DOOR ON PUSH SIDE

THIS TEMPLATE COVERS REGULAR PARALLEL ARM INSTALLATIONS TO 180" OPENINGS.

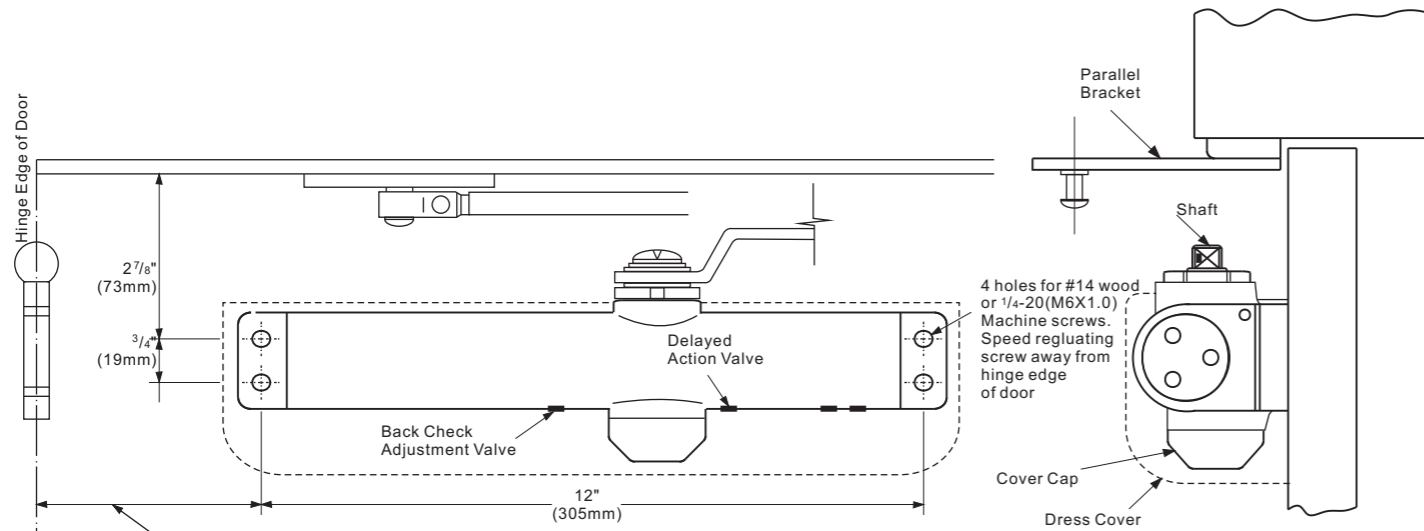

FOR OPENING TO 120" — 4 3/16" (106mm)
FOR OPENING 120" TO 180" — 2 13/16" (71mm)

LEFT HAND DOOR ILLUSTRATED
Same dimensions apply for Right Hand Door measured from the hinge edge.

SPRING TENSION — Door Size Chart

Full turns of Spring adjustment nut	Maximum Door Width		
	Interior Door Size	Exterior Door Size Swing out	Swing in
2	32"(813)	28"(711)	24"(610)
4	36"(914)	32"(813)	28"(711)
6	42"(1067)	36"(914)	32"(813)
8	48"(1219)	42"(1067)	36"(914)
10	54"(1372)	48"(1219)	42"(1067)
11	Maximum Turns		

FOR OPENING TO 120" — 9" (229mm)
FOR OPENING 120" TO 180" — 7 7/8" (194mm)

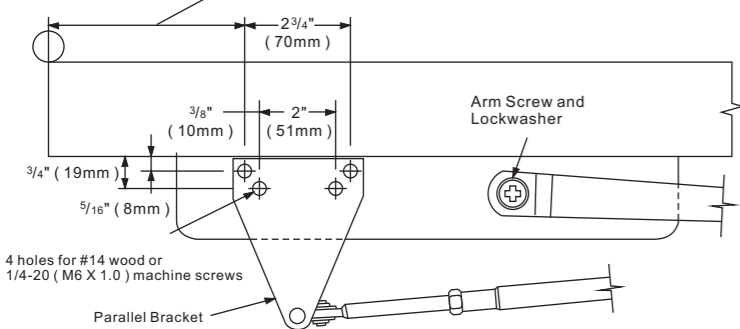

POSITION OF ARMS AND INDEX SETTINGS

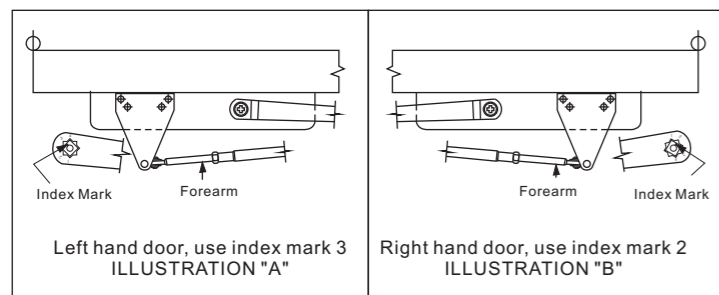

INSTALLATION INSTRUCTIONS

- Select degree of opening and use dimensions shown in above template to mark four holes on door for closer and four holes on frame for parallel bracket.
- Drill pilot holes in door and frame for #14 wood screws or drill and tap for 1/4-20 (M6x1.0) machine screws.
- Mount closer on door WITH SPEED REGULATING SCREW AWAY FROM HINGE EDGE.
- Attach parallel bracket to door stop as illustrated.
- Using a wrench on the square shaft on bottom of closer, rotate shaft approximately 45° toward hinge edge of door. Hold and place main arm on shaft on top of closer at proper index mark as illustrated. FOR LEFT HAND DOOR No. 3 (illustration "A"). FOR RIGHT HAND DOOR No. 2 (illustration "B"). Tighten arm screw with lockwasher securely.
- Remove the arm shoe from the forearm (arm shoe is not used in this application) and place forearm on parallel bracket stud and tighten screw securely.
- Adjust length of forearm so when it is attached to main arm, the main arm will be slightly away from parallel with closed door, and assemble at elbow then tighten locknut.

ADJUSTMENT INSTRUCTIONS

CLOSING POWER — As per "Spring Tension Chart" select the correct number of turns for spring adjustment nut that corresponds with the installation. Using 3/16" (5mm) allen key, turn adjustment nut full 360° clockwise turns to desired setting.

SPEED — Door closing and latching speeds are controlled by #1, #2 speed regulating screw separately.
A. Clockwise turns slow the speed. B. Counterclockwise turns increase the speed.

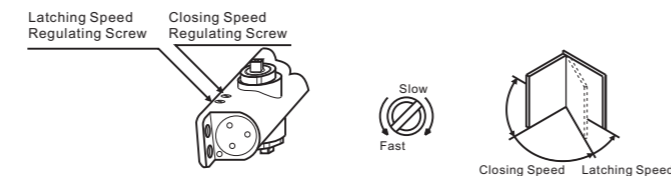

BACK-CHECK ADJUSTMENT — is controlled by the adjustment valve, BACK-CHECK is now set for soft action. To INCREASE Back-check action turn valve CLOCKWISE. To DECREASE, or to TURN OFF Back-check action turn valve COUNTER CLOCKWISE.

DELAYED CLOSING ACTION — is controlled by the Delayed Closing Action Adjustment Valve marked DA on the closer. Delayed Closing Action is now turned off. To TURN ON, or to INCREASE Delayed Closing Action turn valve CLOCKWISE to desired delay time. To DECREASE, or to TURN OFF Delayed Closing Action turn valve COUNTERLOCKWISE.

DRESS COVER — Cutout correct notch for shaft and place dress cover over closer. Attach with truss head machine screw provided, or push COVER CAP over shaft without DRESS COVER.

SUPER ADJUSTABLE

Adjustable Closing Power No Hold-Open SURFACE MOUNTED INSTALLATION INSTRUCTIONS

<p>Series 5050</p>	<p>STANDARD INSTALLATION COLSER MOUNTED ON DOOR ON PULL SIDE</p> <p>PAGE 2</p>	<p>Series 5000</p>
	<p>TOP JAMB INSTALLATION COLSER MOUNTED ON TOP JAMB ON PUSH SIDE OF DOOR</p> <p>PAGE 3</p>	
	<p>PARALLEL INSTALLATION COLSER MOUNTED ON DOOR ON PUSH SIDE</p> <p>PAGE 4</p>	
		<p>CHART TO DETERMINE HAND OF DOOR</p>

STANDARD INSTALLATION CLOSER MOUNTED ON DOOR ON PULL SIDE

THIS TEMPLATE COVERS REGULAR ARM INSTALLATIONS TO 180° OPENINGS.

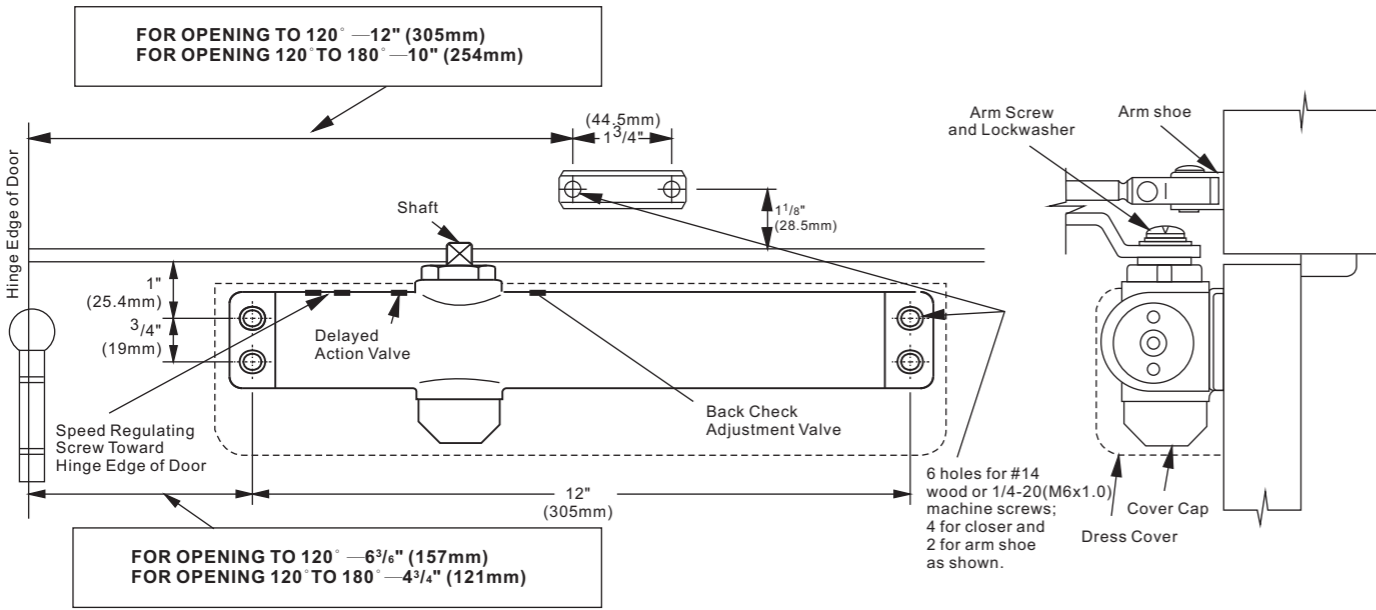

RIGHT HAND DOOR ILLUSTRATED

Same dimensions apply for Left Hand Door measured from the hinge edge.

INSTALLATION INSTRUCTIONS

1. Select degree of opening and use dimensions shown in above template to mark four holes on door for closer and two holes on frame for arm shoe.
2. Drill pilot holes in door and frame for #14 wood screws or drill and tape for 1/4-20(M6x1.0) machine screws.
3. Mount closer on door WITH SPEED REGULATING SCREW TOWARD HINGE EDGE.
4. Place main arm on shaft on top of closer at proper index mark as illustrated. FOR RIGHT HAND DOOR No. 4 (illustration "A") FOR LEFT HAND DOOR No. 1 (illustration "B"). Tighten arm screw with lockwasher securely.
5. Attach the arm shoe of the forearm to the frame.
6. Adjust length of forearm so when it is attached to main arm it will be at a right angle (90°) to door when door is closed and assemble at elbow then tighten locknut.

ADJUSTMENT INSTRUCTIONS

CLOSING POWER — Asper "Spring Tension Chart" select the correct number of turns for spring adjustment nut that corresponds with the installation. Using 3/16" (5mm) allen key, turn adjustment nut full 360° clockwise turns to desired setting.

SPEED — Door closing and latching speeds are controlled by #1,#2 speed regulating screw separately. A. Clockwise turns slow the speed. B. Counterclockwise turns increase the speed.-

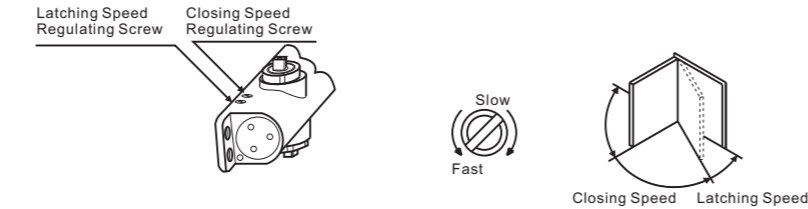

BACK-CHECK ADJUSTMENT — is controlled by the adjustment valve, BACK-CHECK is now set for soft action. To INCREASE Back-check action turn valve CLOCKWISE. To DECREASE, or to TURN OFF Backcheck action turn valve COUNTER CLOCKWISE.

DELAYED CLOSING ACTION — is controlled by the Delayed Closing Action Adjustment Valve marked DA on the closer. Delayed Closing Action is now turned off. To TURN ON, or to INCREASE Delayed Closing Action turn valve CLOCKWISE to desired delay time. To DECREASE, or to TRUN OFF Delayed Closing Action turn valve COUNTER LOCKWISE.

LATCHING POWER — has been set at factory for average conditions. If more latching power is required, move forearm from center hole in arm shoe to hole closest main arm. If less latching power is required, move forearm to hole farthest from main arm.

COVER — Cutout correct notch for shaft and place dress cover over closer. Attach with truss head machine screw provided, or push COVER CAP over shaft without DRESS COVER.

SPRING TENSION — Door Size Chart

Full turns of Spring adjustment nut	Maximum Door Width		
	Interior Door Size	Exterior Door Size Swing out	Swing in
1	32"(813)	28"(711)	24"(610)
3	36"(914)	32"(813)	28"(711)
5	42"(1067)	36"(914)	32"(813)
7	48"(1219)	42"(1067)	36"(914)
9	54"(1372)	48"(1219)	42"(1067)
11	Maximum Turns		

POSITION OF ARMS AND INDEX SETTINGS

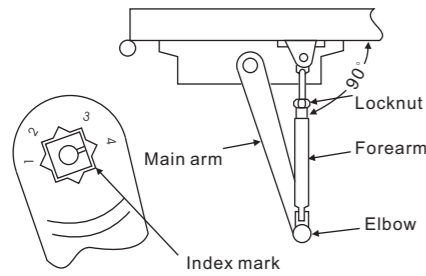

Right hand door. Use index mark 4

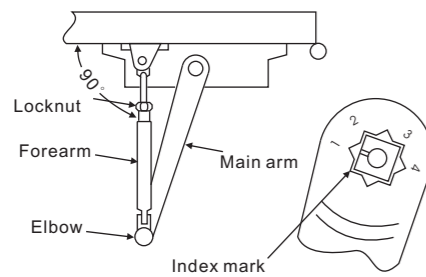

Left hand door. Use index mark 1

TOP JAMB INSTALLATION CLOSER MOUNTED ON TOP JAMB ON PUSH SIDE OF DOOR

THIS TEMPLATE COVERS REGULAR ARM INSTALLATIONS TO 180° OPENINGS.

Reveals of 2 3/4" to 6" require Long Top Jamb Forearms.

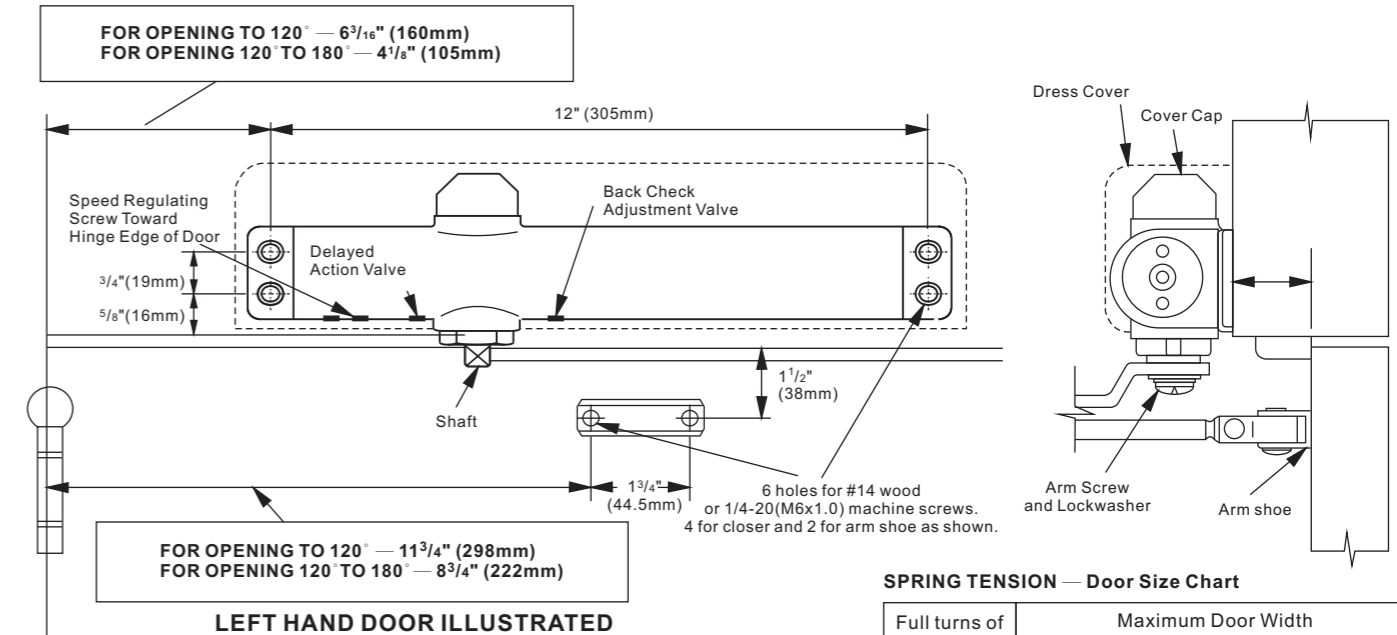

LEFT HAND DOOR ILLUSTRATED

Same dimensions apply for Left Hand Door measured from the hinge edge.

INSTALLATION INSTRUCTIONS

1. Select degree of opening and use dimensions shown in above template to mark four holes on frame for closer and two holes on frame for arm shoe.
2. Drill pilot holes in door and frame for #14 wood screws or drill and tape for 1/4-20(M6x1.0) machine screws.
3. Mount closer on door WITH SPEED REGULATING SCREW TOWARD HINGE EDGE.
4. Place main arm on shaft on bottom of closer at proper index mark as illustrated. FOR RIGHT HAND DOOR No. 4 (illustration "A") FOR LEFT HAND DOOR No. 1 (illustration "B"). Tighten arm screw with lockwasher securely.
5. Attach the arm shoe of the forearm to the door..
6. Adjust length of forearm so when it is attached to main arm it will be at a right angle (90°) to door when door is closed and assemble at elbow then tighten locknut.

ADJUSTMENT INSTRUCTIONS

CLOSING POWER — Asper "Spring Tension Chart" select the correct number of turns for spring adjustment nut that corresponds with the installation. Using 3/16" (5mm) allen key, turn adjustment nut full 360° clockwise turns to desired setting.

SPEED — Door closing and latching speeds are controlled by #1,#2 speed regulating screw separately. A. Clockwise turns slow the speed. B. Counterclockwise turns increase the speed.-

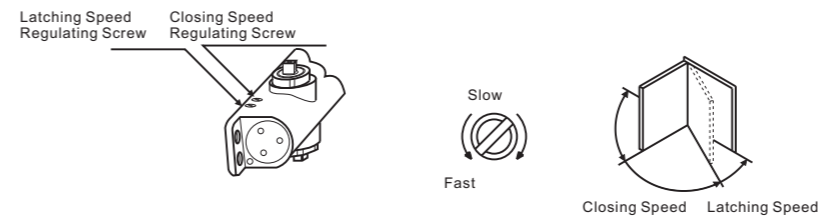

BACK-CHECK ADJUSTMENT — is controlled by the adjustment valve, BACK-CHECK is now set for soft action. To INCREASE Back-check action turn valve CLOCKWISE. To DECREASE, or to TURN OFF Backcheck action turn valve COUNTER CLOCKWISE.

DELAYED CLOSING ACTION — is controlled by the Delayed Closing Action Adjustment Valve marked DA on the closer. Delayed Closing Action is now turned off. To TURN ON, or to INCREASE Delayed Closing Action turn valve CLOCKWISE to desired delay time. To DECREASE, or to TRUN OFF Delayed Closing Action turn valve COUNTER LOCKWISE.

LATCHING POWER — has been set at factory for average conditions. If more latching power is required, move forearm from center hole in arm shoe to hole closest main arm. If less latching power is required, move forearm to hole farthest from main arm.

COVER — Cutout correct notch for shaft and place dress cover over closer. Attach with truss head machine screw provided, or push COVER CAP over shaft without DRESS COVER.

SPRING TENSION — Door Size Chart

Full turns of Spring adjustment nut	Maximum Door Width		
	Interior Door Size	Exterior Door Size Swing out	Swing in
1	32"(813)	28"(711)	24"(610)
3	36"(914)	32"(813)	28"(711)
5	42"(1067)	36"(914)	32"(813)
7	48"(1219)	42"(1067)	36"(914)
9	54"(1372)	48"(1219)	42"(1067)
11	Maximum Turns		

POSITION OF ARMS AND INDEX SETTINGS

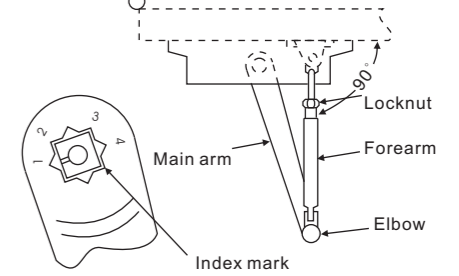

Left hand door. Use index mark 1

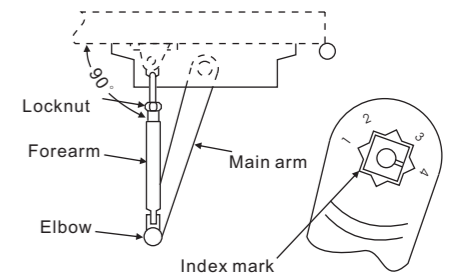

Right hand door. Use index mark 4