

INSTRUCTIONS FOR INSTALLING HEAVY DUTY CYLINDRICAL BORED LOCK

A

INSTALL LATCH UNIT
AFTER PREPARING DOOR AND JAMB ACCORDING TO TEMPLATE PROVIDED- MOUNT LATCH UNIT IN DOOR.

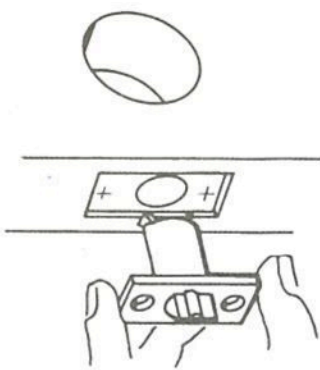

LATCH UNITS WITH DRIVE IN FRONTS MUST BE POSITIONED WITH BOLT FACE VERTICAL



B

REMOVE INSIDE KNOB OR HANDLE*
IF RECEIVED WITH KNOB OR HANDLE ENGAGED DEPRESS KNOB CATCH WITH TOOL PROVIDED AND PULL KNOB OR HANDLE OFF SPINDLE. *KNOB TRIM ILLUSTRATED

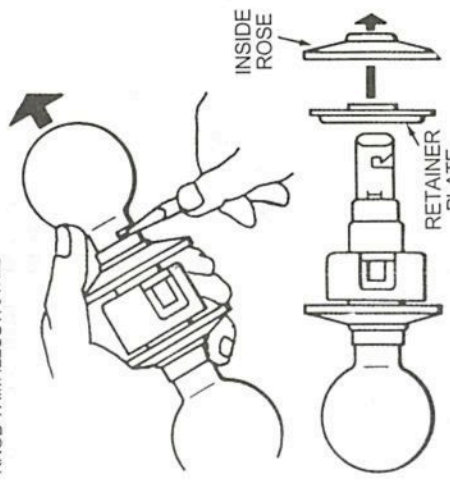

REMOVE ROSE AND RETAINER PLATE
NOTE: LOCKS WITH THREADED INSIDE ROSES DO NOT HAVE RETAINER PLATES. UNSCREW TO REMOVE.

C

ADJUST FOR DOOR THICKNESS

ROTATE OUTSIDE ROSE IN OR OUT DEPENDING ON DOOR THICKNESS. LOCK WILL FIT ANY DOOR FROM 1 3/8" TO 2".

- 1/8" GAP FOR 1-3/8" DOORS
- 1/4" GAP FOR 1-3/4" DOORS
- 3/8" GAP FOR 2" DOORS

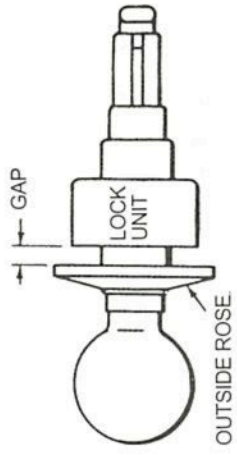

D

INSTALL LOCK UNIT*

LOCK UNIT HOUSING MUST ENGAGE LATCH UNIT PRONGS AND RETRACTOR MUST ENGAGE LATCH TAILPIECE. NOTE: IF GUARD BOLT FUNCTION IS INSTALLED, DO NOT ATTEMPT TO MOUNT LOCK UNIT WHEN DOOR IS CLOSED. GUARD BOLT TAILPIECE WILL INTERFERE. NOTE: DEPRESS LATCH BOLT SLIGHTLY TO ALLOW RETRACTOR TO ENGAGE LATCH TAILPIECE.

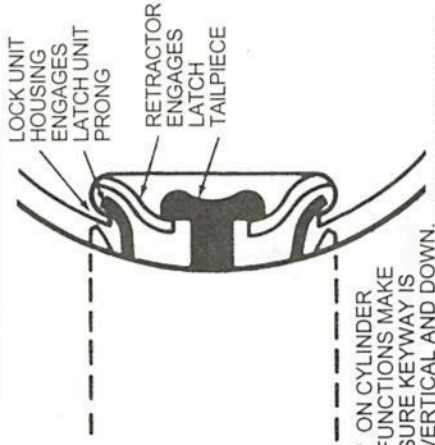

* ON CYLINDER FUNCTIONS MAKE SURE KEYWAY IS VERTICAL AND DOWN. SEE NOTE BELOW TO REVERSE CYLINDER

E

ATTACH INSIDE ROSE
SNAP ON ROSES: SLIP ON RETAINER PLATE AND FASTEN WITH TWO MACHINE SCREWS. POSITION SPRING CLIP NOTCH AND SNAP ROSE OVER RETAINER PLATE.

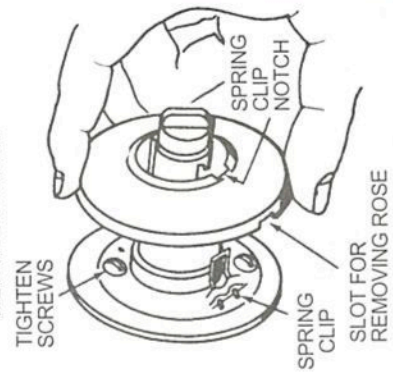

TIGHTEN SCREWS
SLIP ROSE OVER SPINDLE AND SCREW DOWN FIRMLY USING TRIM WRENCH PROVIDED

F

REPLACE INSIDE KNOB OR HANDLE

LINE UP SLOT IN KNOB WITH KNOB CATCH IN SPINDLE. SLIDE KNOB OR HANDLE ON TO SPINDLE. DEPRESS KNOB CATCH AND PUSH KNOB OR HANDLE INTO ENGAGED POSITION. NOTE: B KNOB BUTTON SETS SHOULD BE IN THE UNLOCKED POSITION WHEN REPLACING THE INSIDE KNOB OR HANDLE

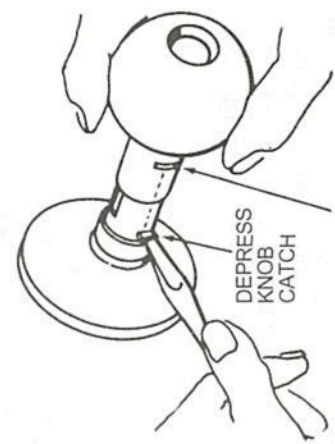

NOTE: WHEN A CYLINDER FUNCTION LOCK IS CORRECTLY INSTALLED, THE KEY SHOULD ENTER IN THIS POSITION.

IF NOT, REVERSE CYLINDER AS FOLLOWS:

1. WITH INSIDE KNOB UNLOCKED, INSERT A KEY INTO CYLINDER.
2. TURN KEY ABOUT 45° DEGREE.
3. PRESS RETAINER THRU SLEEVE HOLE BY USING TOOL PROVIDED AND PULL KNOB OUT.
4. TURN LOCKSET TO OPPOSITE SIDE WHERE YOU WISH TO REVERSE.
5. PUT OUTSIDE KNOB WITH KEY-IN-CYLINDER BACK INTO SPINDLE UNTIL TAIL-PIECE CAN ENGAGE RETRACTOR (FEEL RETRACTS BY TURNING KEY SLIGHTLY)
6. TURN KEY ABOUT 45° DEGREE AND PUSH KNOB IN UNTIL RETAINER CLICKS INTO POSITION.

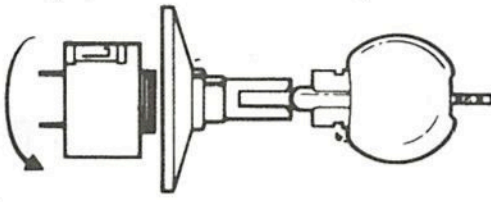

* TURN LOCKSET TO OPPOSITE SIDE WHERE YOU WISH TO REVERSE.

* OUTSIDE KNOB & CYLINDER ALWAYS BEING IN THIS POSITION

SEE REVERSE SIDE FOR CYLINDER KNOB ASSEMBLY

CYLINDER REASSEMBLY

1. PUSH KNOB WITH KEY - IN - CYLINDER BACK INTO SPINDLE UNTIL TAIL - PIECE CAN ENGAGE RETRACTOR (FEEL RETRACTS BY TURNING KEY SLIGHTLY)
2. TURN KEY ABOUT 45° DEGREE AND PUSH KNOB IN UNTIL BETAINDER CLICKS INTO POSITION.

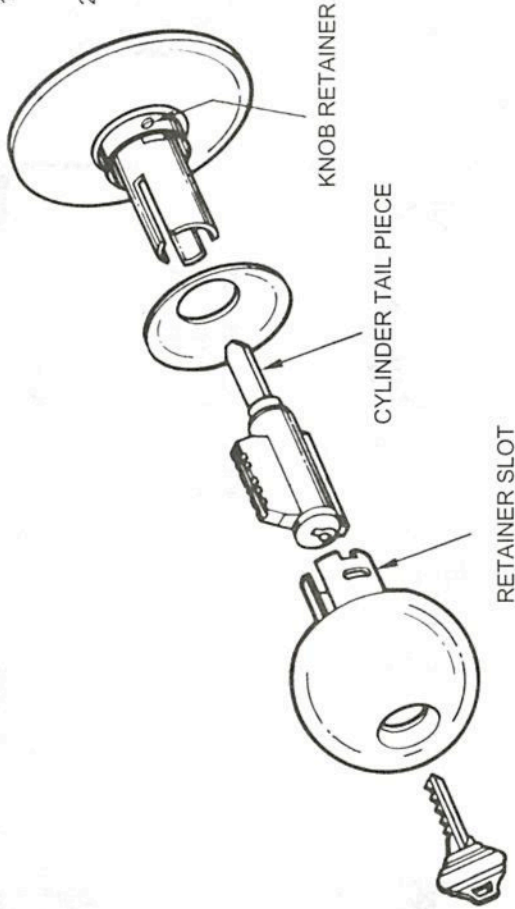

CAUTION FOR CLASSROOM FUNCTION

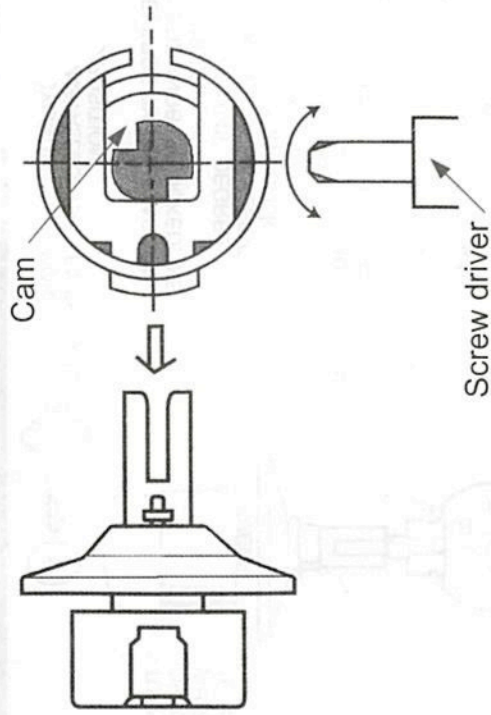

- (1) **Locking** Turn key counter-clockwise. Return to take a key out.
- (2) **Unlocking** Turn key clockwise. Return to take a key out.

Make sure to turn cam counter clockwise with a screw driver as far as it will go before reassembling of cylinder to prevent mis-positioning of cam for classroom function.

INTERCHANGEABLE CORE HOW TO REPLACE



HOW TO REPLACE CORE :
With control key fully inserted, insert core into knob. Turn control key to the right, then return key to vertical and remove from core.

HOW TO REMOVE KNOB :
Insert a pin through cylinder chamber of knob.
Press down knob catch (retainer spring) and pull knob out.

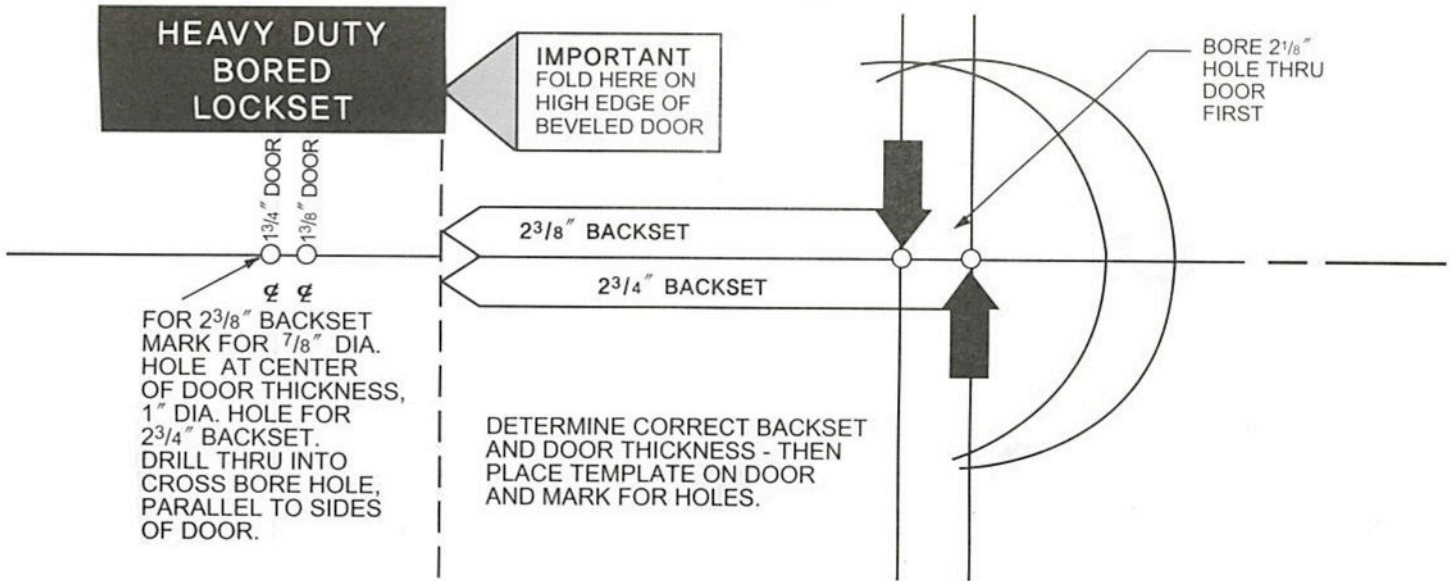

TO MORTISE DOOR FOR LOCK

- 1** DETERMINE CORRECT BACKSET AND DOOR THICKNESS - THEN PLACE TEMPLATE ON DOOR AND MARK FOR HOLES.

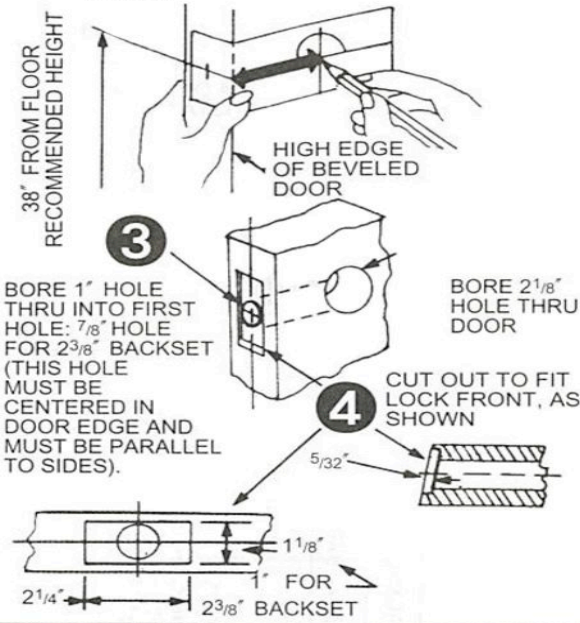

TO MORTISE FRAME FOR STRIKE

