



1921



HELMUT ZEPF  
MEDIZINTECHNIK GMBH



HELMUT ZEPF  
MEDIZINTECHNIK GMBH



HELMUT ZEPF  
1921-2021

2021



*The better grade of dental instruments since 1921*

# Goldener Meisterbrief

Helmut Zepf

Chirurgiemechanikermeister

FÜR 40 JAHRE MEISTER DES DEUTSCHEN HANDWERKS  
VERLIEHEN VON DER HANDWERKSKAMMER KONSTANZ

  
PRÄSIDENT



  
SYNDIKUS

KONSTANZ, DEN 29. MAERZ 1987

100 YEARS MADE IN GERMANY



1921

1938

1956

1978



Qualitäts-Erzeugnisse



HELMUT ZEPF



**True craftsmanship** The Helmut Zepf Medizintechnik GmbH success began in 1921 with one of the most influential surgeons of the 20th century, Prof. Ernst Ferdinand Sauerbruch. The pioneer of thoracic surgery is known worldwide for his groundbreaking surgical methods. Simple surgical instruments do not meet his high expectations. In his quest for high-quality instruments, he turned to Isidor Zepf, a small instrument producer in the town of Seitingen-Oberflacht, in the Swabia region of southern Germany. The professor has very specific ideas, and Isidor Zepf promises him a solution for a surgical instrument set for an arm or leg prosthesis. To Sauerbruch's delight, he solves this tricky task with flying colors. The foundation stone is laid for success in the years to come, and history takes its course.

**100 years and four generations** 100 years and four generations later, Helmut Zepf Medizintechnik GmbH stays true to this promise. According to its mission statement "Aesthetic is the result", the company develops innovative solutions in close cooperation with renowned physicians and health professionals. Many years of experience and sound knowledge of the field of application are incorporated in the developments. The focus is on functionality, ergonomics and safety, all packaged in an attractive design. A one-man business has grown into a leading manufacturer of medical and surgical instruments.

Over the years, the product portfolio has matured in the areas of diagnostics, periodontology, conservation, extraction, dental surgery, implantology, microsurgery and dental technology. Then there are the Zepfcare product families, with useful accessories, as well as CMF (Cranio Maxillofacial Fracture) systems. The company now offers a wide range of products and supplies implantologists and orthodontists in over 70 countries. Craftsmanship "Made in Germany".

**Tuttlingen** Besides the strong family ties, the Tuttlingen location, as a world center for medical technology, also contributes to the company's affinity towards its origins in Seitingen-Oberflacht. New production buildings, state-of-the-art manufacturing facilities and IT technologies have been created in recent years. Over 100 employees work on the company site today. Numerous products leave the 3,500 sqm production facility daily, making their way all over the world via the internal logistics center. With its high density of qualified specialists, Helmut Zepf Medizintechnik GmbH has always managed to assert itself as a trendsetter in the field of dental hand instruments. The team is supported by expert quality management, ensuring product safety in terms of medical standards and the highest hygiene regulations.





1992



2005



2021



**A family** The employees play an important role in the history of Helmut Zepf Medizintechnik GmbH. As a family company, we are aware of the responsibility this entails. Modern jobs in the workplace, flat hierarchies and special benefits continue to contribute to the informal working atmosphere, while exciting training opportunities enhance attractiveness for young talent. The company demonstrates its close ties with the region and its people through its social commitment in local organizations, among other things.

**Helmut Zepf Medizintechnik GmbH today** Following in the footsteps of his predecessors Isidor Zepf, Helmut Zepf Senior and Helmut Zepf Junior, Patrick Zepf took over the reins of the family company in 2018. True to the motto of the company founder: "high quality criteria and openness for innovation", Patrick Zepf also successfully follows this mission. The family looks back over the past 100 years with pride. Over generations, it has managed to withstand crises, to recognise the trends of the times and to encounter them with an open mind.

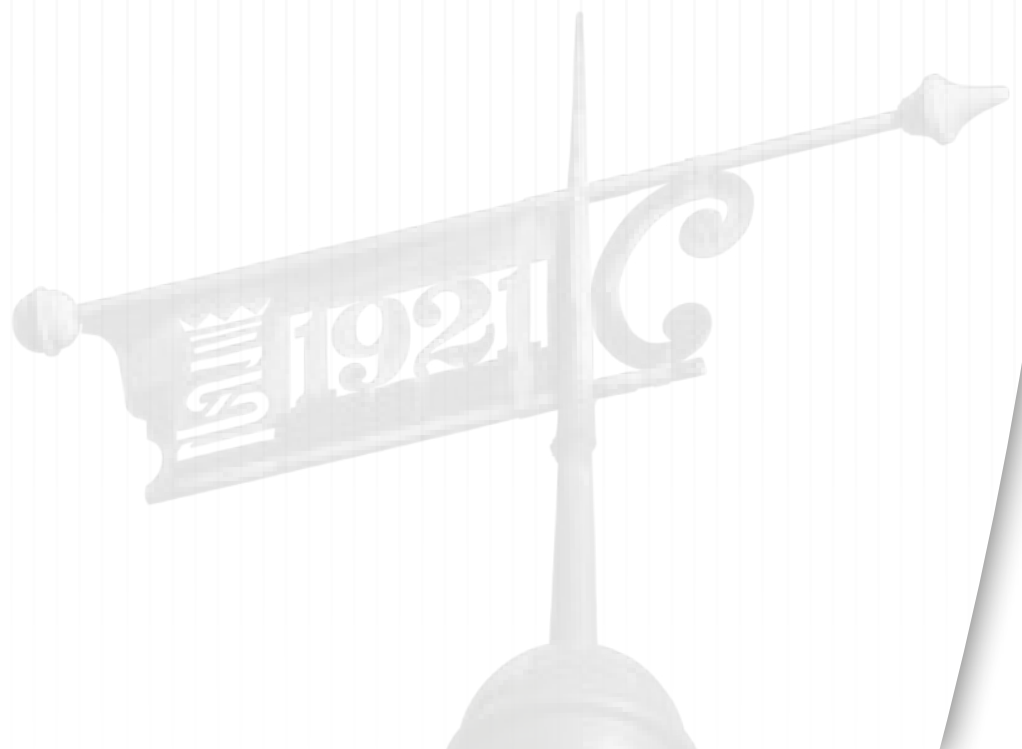



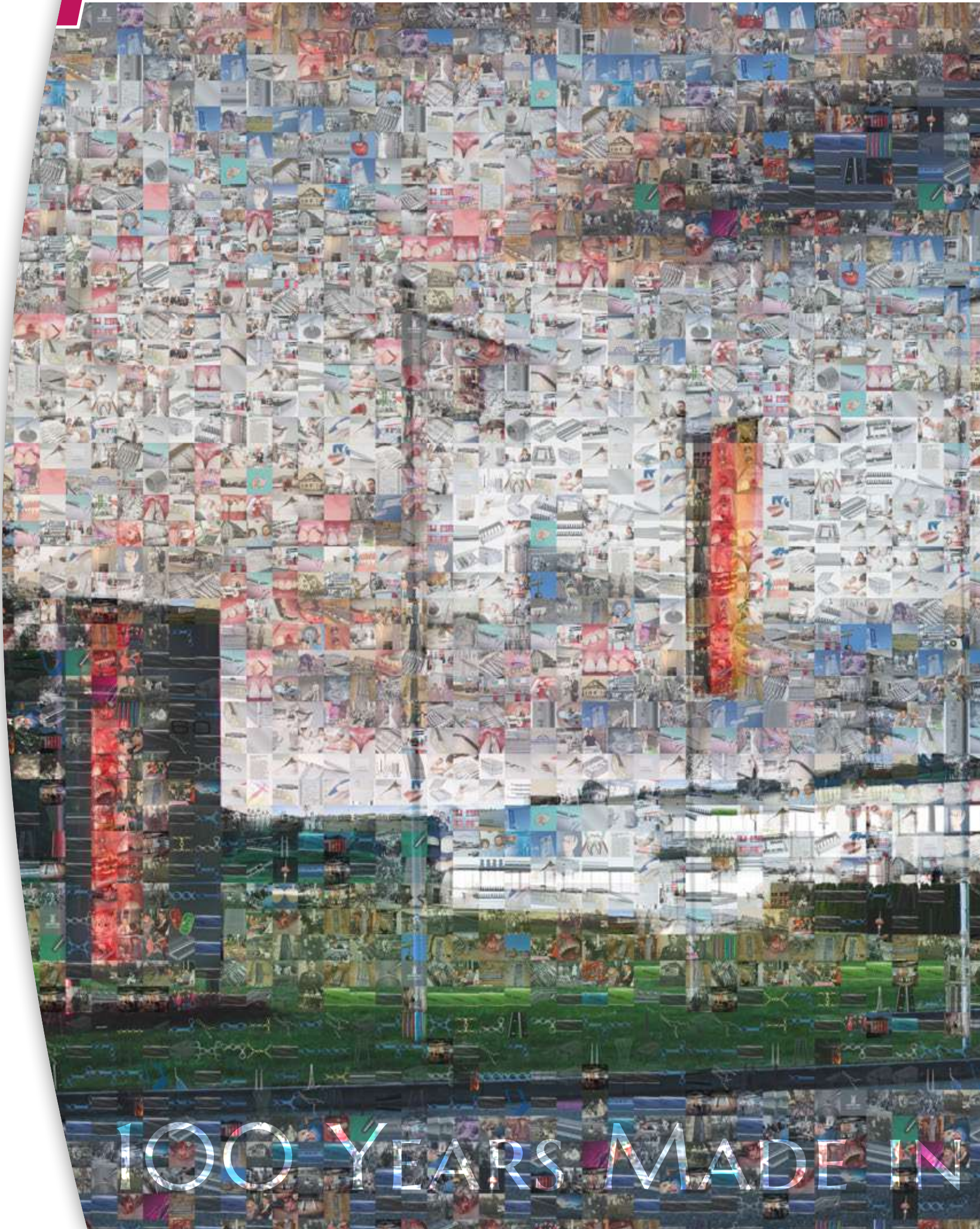

100 YEARS MADE IN



100 YEARS MADE IN GERMANY

*essentials* 7

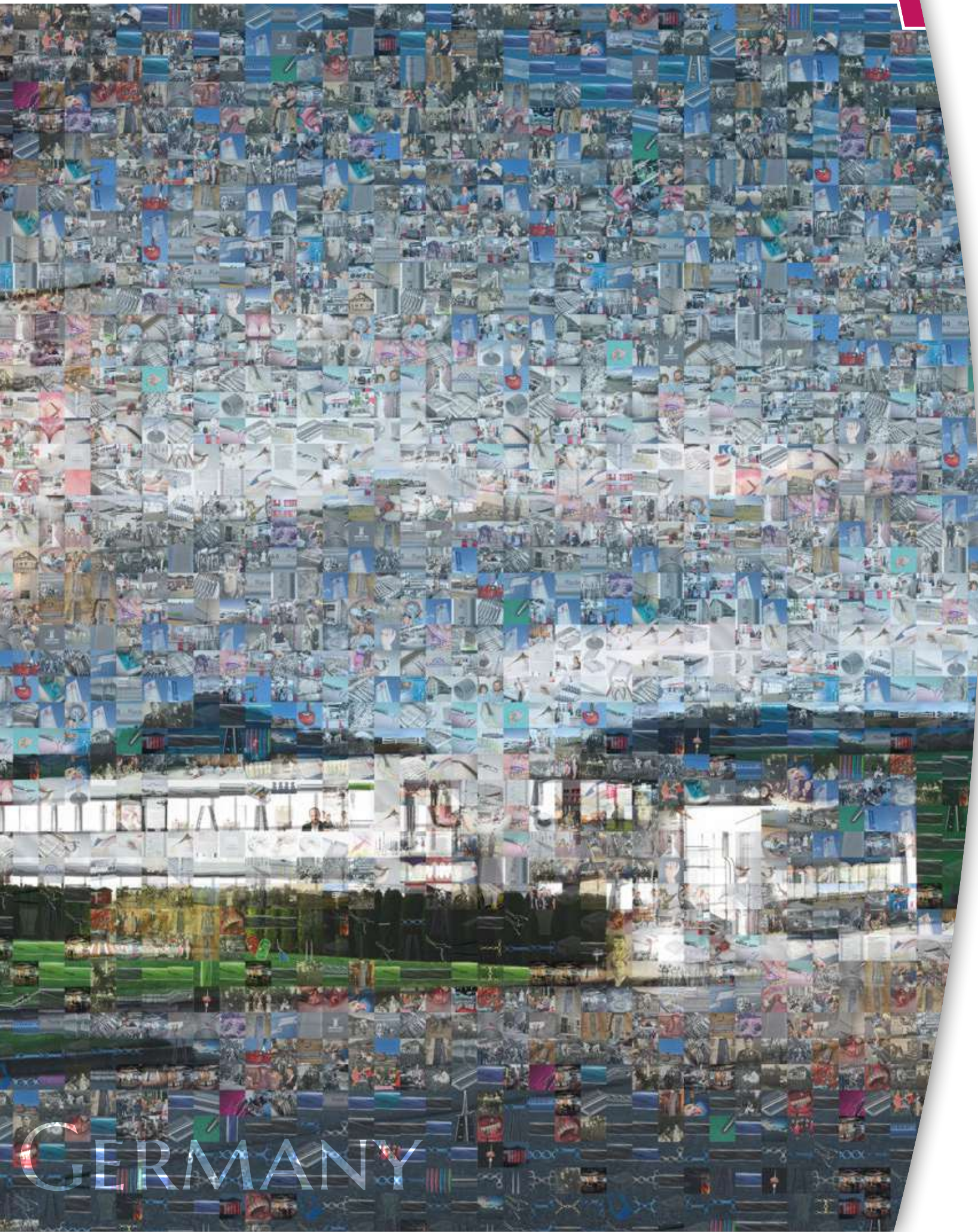

GERMANY



## ZEPF BIONIK Prophylaxis Sets

The **HELMUT ZEPF BIONIK** handle corresponds with the demand of an anatomically adjusted handle for prophylaxis. The perfect shape regarding power transmission and sensitivity enables a tactile curetting and scaling.

The adaptation of the practice-oriented requirements regarding communication, hygienics and flexibility make the **HELMUT ZEPF BIONIK** handle the perfect instrument holder not only for dental diagnosis and prophylaxis, but also for surgery, implantology and microsurgery.

All inserts are exchangeable. **QUICKFIX**



reddot design award  
winner 2010

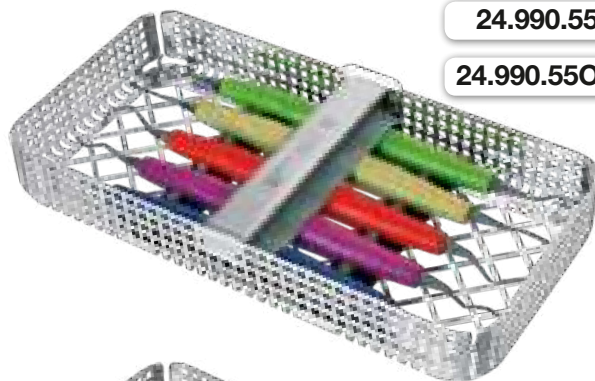

24.990.55

24.990.55OX

### ZEPF BIONIK Prophylaxis Set M5 'Deep Scaling'

Set with nanopal coating

For an optimal subgingival access. Consisting of Gracey 1/2 M5, 7/8 M5, 11/12 M5, 13/14 M5, Scaler 204S and 1/3 Washtray.

With the nanopal coating the surface hardness is increased to 4500 vickers – as never seen before. The blade is highly quenched and does not need to be sharpened.

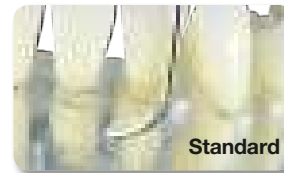

Standard



M5

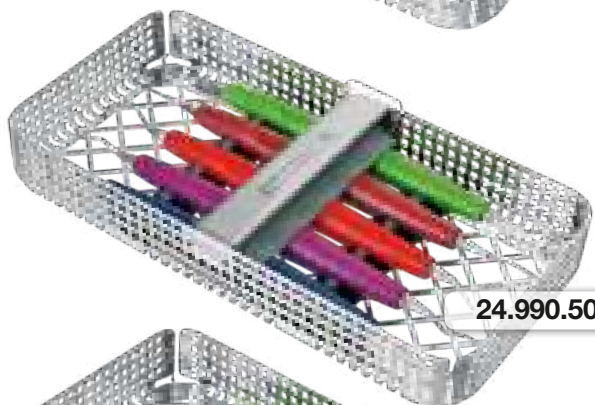

24.990.50

### ZEPF BIONIK Prophylaxis Set 'Gracey'

consisting of Gracey 5/6, 7/8, 11/12, 13/14, Scaler 204S and 1/3 Washtray

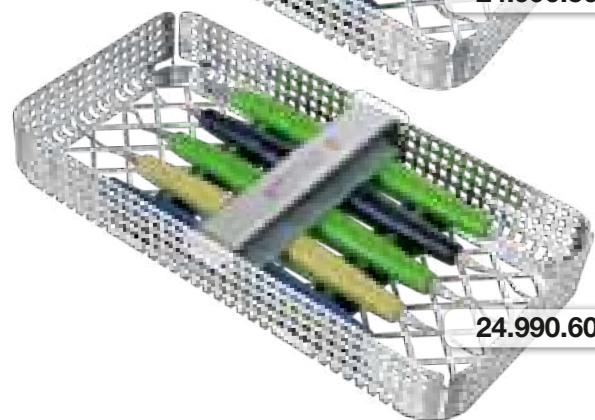

24.990.60

### ZEPF BIONIK Prophylaxis Set 'Universal'

consisting of Langer 1/2, 3/4, 5/6, M23, Scaler 204S and 1/3 Washtray



## Color Coding ZEPF BIONIK Gracey Special Curettes









### Incisors / Canines

	<b>GRA 1/2</b>	$\frac{3-1}{3-1} \mid \frac{1-3}{1-3}$
	<b>GRA 3/4</b>	$\frac{5-1}{5-1} \mid \frac{1-5}{1-5}$
	<b>GRA 5/6</b>	$\frac{5-1}{5-1} \mid \frac{1-5}{1-5}$



### Premolars / Molars

	<b>GRA 7/8</b>	$\frac{8-4}{8-4} \mid \frac{4-8}{4-8}$
	<b>GRA 9/10</b>	$\frac{8-4}{8-4} \mid \frac{4-8}{4-8}$
	<b>GRA 11/12</b>	$\frac{8-4}{8-4} \mid \frac{4-8}{4-8}$

	<b>GRA 13/14</b>	$\frac{8-4}{8-4} \mid \frac{4-8}{4-8}$
	<b>GRA 15/16</b>	$\frac{8-4}{8-4} \mid \frac{4-8}{4-8}$
	<b>GRA 17/18</b>	$\frac{8-4}{8-4} \mid \frac{4-8}{4-8}$

## Explorer 11/12

delicate, in **ZEPF BIONIK** Handle

The Explorer 11/12 with **ZEPF BIONIK** handle features delicate and pointed tips. For subgingival root examination. To explore pockets, restorations, furcations and to diagnose proximal and cervical calculus and caries.



**24.440.00**

Explorer 11/12, double-ended, in **ZEPF BIONIK** handle, signal purple, delicate, pointed tips, angles according to Gracey 11/12

## Titanium Periodontal Probe

North Carolina CNC, in **ZEPF BIONIK** Handle

PA Probe North Carolina CNC, now also in titanium, complete in the **BIONIK** handle.

PA probes are used to measure pocket depths. Probing along the root or the implant as an indispensable examination to detect the inflammatory activity and the corresponding bone resorption.

Due to peri-implantitis (inflamed tissue around an implant), gum inflammation and bone resorption can also occur with implants, so regular checking of pocket depths is essential.

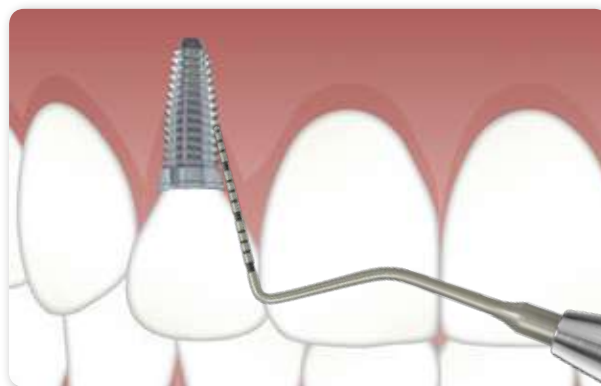

In this illustration, the pocket depth is measured with a **titanium** PA probe to avoid damage of the sensitive titanium surface of the implant.

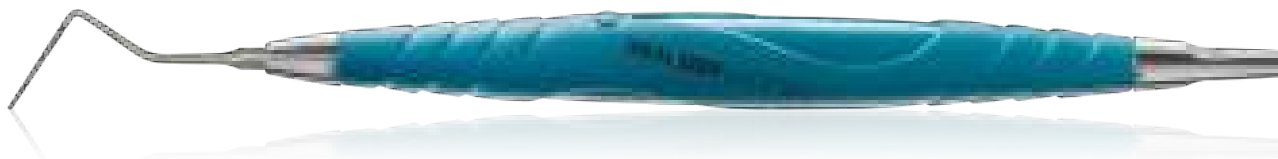

**24.216.06**

Periodontal Probe, North Carolina, CNC, 1-15 mm, titanium, in **BIONIK** handle, single-ended, M2.5, turquoise-brightblue



ZEPF **BIONIK** M5 Titanium Currettes 

**HELMUT ZEPF** M5 Titanium Currettes have a 1st shaft which is about 3 mm longer.  
To remove the accumulated plaque film on the implant necks.



Available as accessories:

24.926.75

**Test Probe, Acrylic Glass** 76 x 6 mm, PU = 6 pieces and

24.950.00

**Sharpening Oil** 100 ml, for Original **ZEPF** and Arkansas Stones

24.990.55TI

**ZEPF BIONIK** Prophylaxis Set 'Titanium M5 Gracey', consisting of Gracey 1/2 M5-TI, 7/8 M5-TI, 11/12 M5-TI, 13/14 M5-TI and 1/3 Washtray



GRA 1/2 M5 Special Curette, for front teeth, slightly angled, yellow

24.201.01GM5-TI



GRA 7/8 M5 Special Curette, for premolars / molars, more sharply angled, lightred-magenta

24.205.07GM5-TI



GRA 11/12 M5 Special Curette, for use on all mesial surfaces of premolars / molars. Skewed to allow optimal placement, signal purple

24.204.11GM5-TI



GRA 13/14 M5 Special Curette, for use on all distal surfaces of premolars / molars. Skewed to allow optimal placement, cobalt blue

24.207.13GM5-TI



Hygienist, # H 6/7, Sickle Scaler with opposed tips, **very fine version**, for front teeth and premolars, yellow-green

24.208.06HF

**Titanium version** with regular tips, yellow-green

24.208.06H-TI



**LANGER Universal Curette # L 17/18**  
in **ZEPF BIONIK** Handle

The new Langer Curette # L 17/18 has the same bending as the Gracey # GRA 17/18 and thus is the perfect complement to our range of Universal Curettes.

Unlike the Gracey Curettes, Universal Curettes have two working ends / cutting edges, so that concretions on the tooth neck as well as inflamed tissue in the pockets can be removed simultaneously in one step.

The triple bend of the working ends provides optimal access, especially in the distal premolar and molar area and even when mouth opening is restricted.

The **ZEPF BIONIK** handle is designed according to the ergonomic needs of a curettage. With **QUICKFIX** the system for a quick and easy change of the working ends.



8-4	4-8
8-4	4-8

**24.207.17L**

**Langer # L 17/18**, Universal Curette for use on upper and lower molars and premolars, in **ZEPF BIONIK** handle cobalt blue, inserts exchangeable

**BIONIK** Condenser, titanium, with graduation  
to condense augmentation material on the implant

**24.532.19**

Condenser, titanium, with depth measurement, exchangeable tips, serrated, M4 x 0.5 metric thread, Bionik handle, yellow-green

**Graduation:** 3.0 mm  
6.0 mm  
9.0 mm  
12.0 mm  
15.0 mm

Ø 1.0 mm

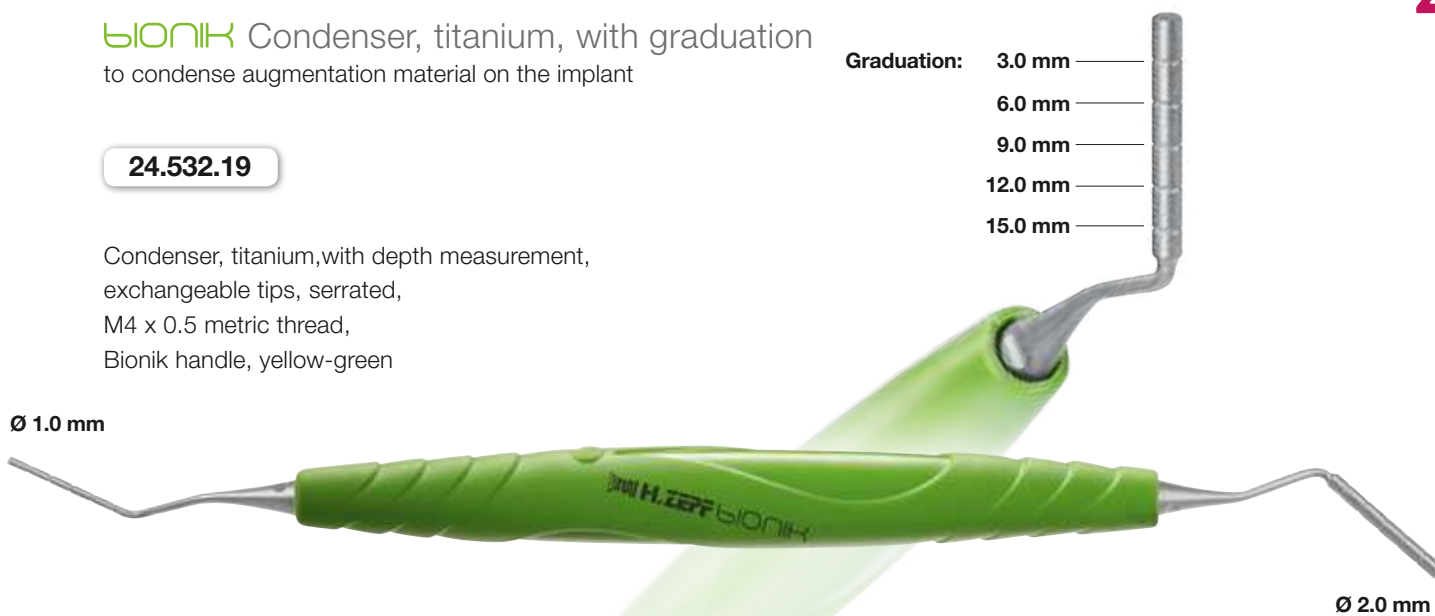

**BIONIK**  
**BIONIK**



reddot design award  
winner 2010

**BIONIK Universal Handle** Universal Handle made of PEEK high-tech plastic material – guarantees an ideal power transmission with formerly unknown sensitivity.

## Langer Universal Currettes

in **ZEPF BIONIK** handle

Unlike Gracey Currettes, Universal Currettes have two working surfaces / cutting edges, so that concretions on the tooth neck as well as inflamed tissue in the pockets can be removed simultaneously in one step. The 3 instruments (Langer fig. 1/2, 3/4 and 5/6) allow an efficient prophylaxis treatment in all quadrants.



## Langer Universal Titanium Currettes

in **ZEPF BIONIK** handle

The Langer currettes with titanium inserts are ideal for removing attached plaque layers on the implant necks. The titanium material does not damage the surface of the implant.

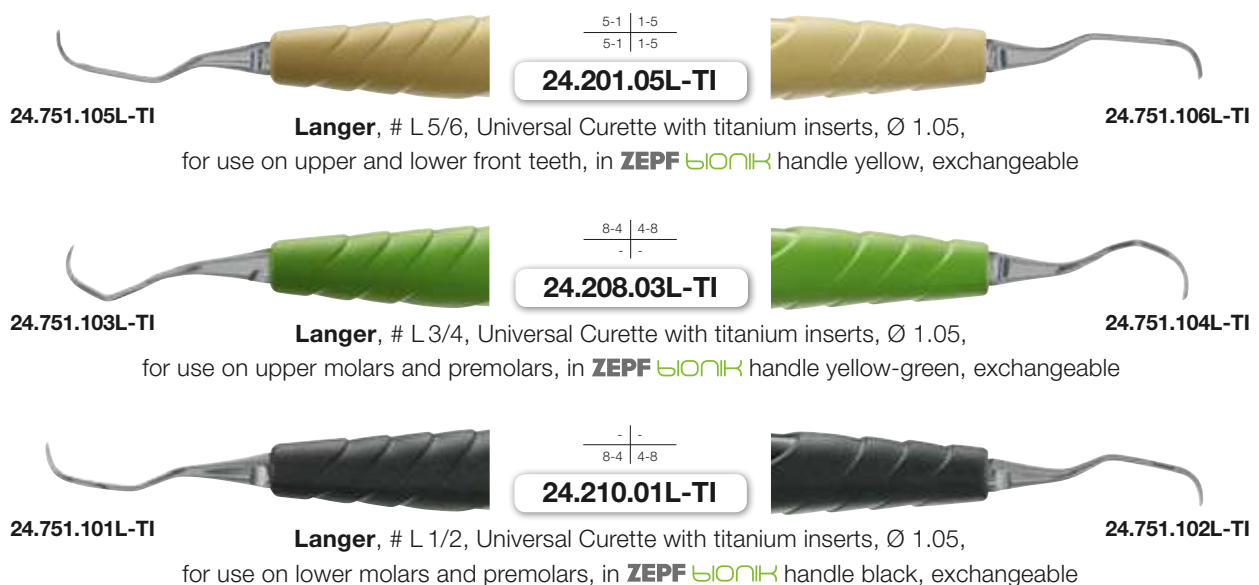

## Langer M5 Universal-Küretten im ZEPF BIONIK Griff

The new Zepf Langer M5 universal curettes are especially suitable for deep scaling – for removing deposits on tooth or root surfaces and simultaneously removing inflamed tissue. Due to the ground working end on both sides, the M5 Langer curettes are used especially for very deep pockets – in the closed periodontosis treatment.



The 3 mm longer 1st shaft facilitates access into deep gingival pockets (deeper than 5 mm). The shortened working end allows a special subgingival curettage for narrow and deep pockets and narrow root surfaces. Due to the 0.95 mm thin, flexible and thus tactile 1st shaft, the curettes adapt optimally to the deep-lying root.

<p>24.751.105LM5</p> 	<table border="1" style="margin: 0 auto;"> <tr><td>5-1</td><td>1-5</td></tr> <tr><td>5-1</td><td>1-5</td></tr> </table> <p><b>24.201.05LM5</b></p>	5-1	1-5	5-1	1-5	 <p>24.751.106LM5</p>
5-1	1-5					
5-1	1-5					
<p><b>Langer, # L 5/6, M5 Curette, Ø 0.95,</b> for use on upper and lower front teeth, in ZEPF BIONIK handle yellow, exchangeable</p>						
<p>24.751.103LM5</p> 	<table border="1" style="margin: 0 auto;"> <tr><td>8-4</td><td>4-8</td></tr> <tr><td>-</td><td>-</td></tr> </table> <p><b>24.208.03LM5</b></p>	8-4	4-8	-	-	 <p>24.751.104LM5</p>
8-4	4-8					
-	-					
<p><b>Langer, # L 3/4, M5 Curette, Ø 0.95,</b> for use on upper molars and premolars, in ZEPF BIONIK handle yellow-green, exchangeable</p>						
<p>24.751.101LM5</p> 	<table border="1" style="margin: 0 auto;"> <tr><td>-</td><td>-</td></tr> <tr><td>8-4</td><td>4-8</td></tr> </table> <p><b>24.210.01LM5</b></p>	-	-	8-4	4-8	 <p>24.751.102LM5</p>
-	-					
8-4	4-8					
<p><b>Langer, # L 1/2, M5 Curette, Ø 0.95,</b> for use on lower molars and premolars, in ZEPF BIONIK handle black, exchangeable</p>						



## Langer M5 Universal Curettes with nanopal® coating in ZEPF BIONIK handle

The black-coated ZEPF nanopal® curettes have a durable, very hard surface which is very aggressive and sharp-edged due to its crystalline nanostructure. Due to the unique coating, the surface hardness is increased to an unprecedented **4500 Vickers**.

The cutting edge is thus highly tempered and does not need to be re-sharpened after each curettage. The black, scratch-resistant surface is easy to clean and prevents unpleasant light reflections.

<p>24.751.105LM5OX</p> 	<table border="1" style="margin: 0 auto;"> <tr><td>5-1</td><td>1-5</td></tr> <tr><td>5-1</td><td>1-5</td></tr> </table> <p><b>24.201.05LM5OX</b></p>	5-1	1-5	5-1	1-5	 <p>24.751.106LM5OX</p>
5-1	1-5					
5-1	1-5					
<p><b>Langer, # L 5/6, M5 Curette with ZEPF nanopal® coating, Ø 0.95,</b> for use on upper and lower front teeth, in ZEPF BIONIK handle yellow, exchangeable</p>						
<p>24.751.103LM5OX</p> 	<table border="1" style="margin: 0 auto;"> <tr><td>8-4</td><td>4-8</td></tr> <tr><td>-</td><td>-</td></tr> </table> <p><b>24.208.03LM5OX</b></p>	8-4	4-8	-	-	 <p>24.751.104LM5OX</p>
8-4	4-8					
-	-					
<p><b>Langer, # L 3/4, M5 Curette with ZEPF nanopal® coating, Ø 0.95,</b> for use on upper molars and premolars, in ZEPF BIONIK handle yellow-green, exchangeable</p>						
<p>24.751.101LM5OX</p> 	<table border="1" style="margin: 0 auto;"> <tr><td>-</td><td>-</td></tr> <tr><td>8-4</td><td>4-8</td></tr> </table> <p><b>24.210.01LM5OX</b></p>	-	-	8-4	4-8	 <p>24.751.102LM5OX</p>
-	-					
8-4	4-8					
<p><b>Langer, # L 1/2 M5 Curette with ZEPF nanopal® coating, Ø 0.95,</b> for use on lower molars and premolars, in ZEPF BIONIK handle black, exchangeable</p>						

## Langer M5 Universal Curettes, delicate version

in **ZEPF BIONIK** handle

Analogous to the standard Langer Universal Curettes, the delicate versions also have two working or cutting edges, so that concretions on the tooth neck and inflamed tissue in the pockets can be removed simultaneously in one step. Due to the 0.95 mm thin, flexible and thus tactile 1st shaft, they adapt optimally to the tooth necks.



## Langer Universal Curettes, delicate version with nanopal® coating

in **ZEPF BIONIK** handle

The black-coated **ZEPF nanopal®** curettes have a durable, very hard surface which is very aggressive and sharp-edged due to its crystalline nanostructure. Due to the unique coating, the surface hardness is increased to an unprecedented **4500 Vickers**.

The cutting edge is thus highly tempered and does not need to be re-sharpened after each curettage. The black, scratch-resistant surface is easy to clean and prevents unpleasant light reflections.

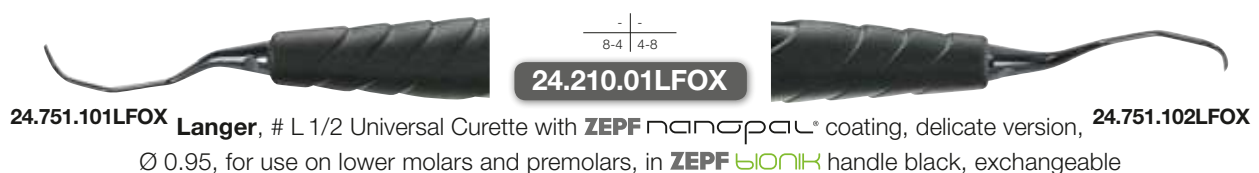
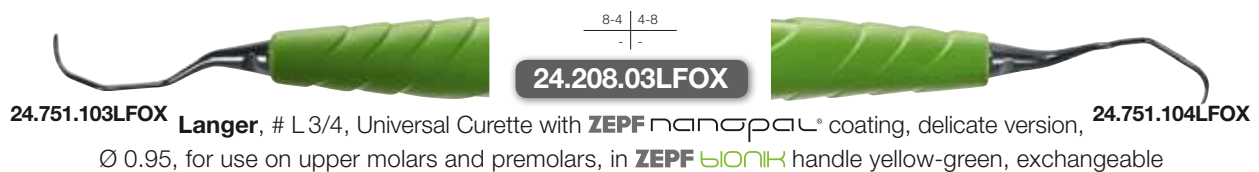
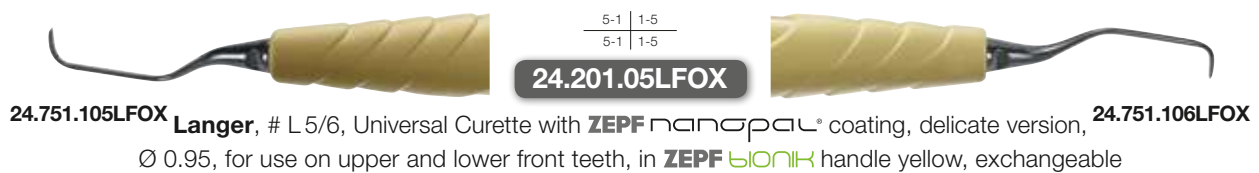

# The new handle generation!

## Z-SHAPE RELAX

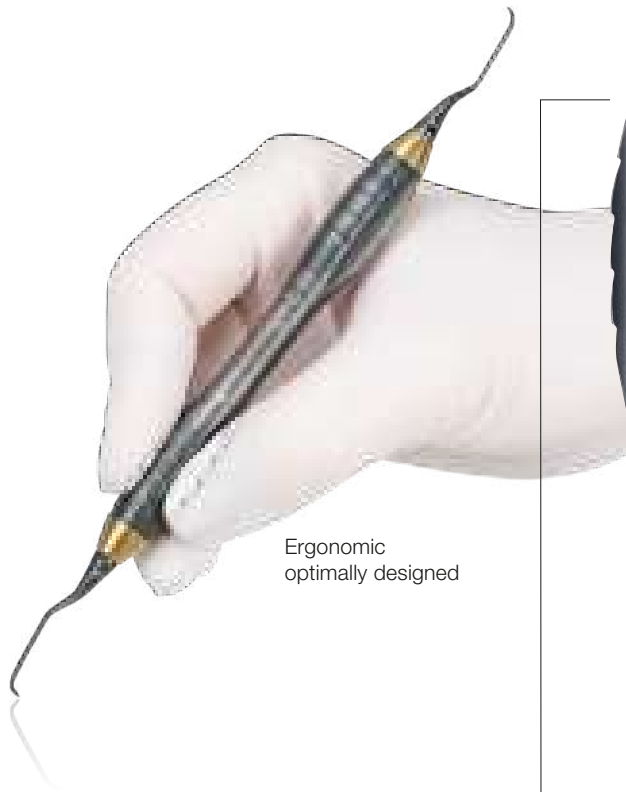

Ergonomic  
optimally designed

The new **ZEPF** Gracey curettes have a 0.95 mm thin, flexible and therefore tactile 1st shaft. Thus, the curettes offer a perfect adaption to deep-lying roots.

The black-coated **ZEPF nanopal**® curettes have a durable, very hard surface which is very aggressive and sharp-edged, due to their crystalline nanostructure. With the unique coating, the surface hardness is increased to an unprecedented **4500 Vickers**. The cutting edge is thus highly tempered and does not need to be re-sharpened after each curettage. The black, scratch-resistant surface is easy to clean and prevents unpleasant light reflections.

As usual with **QUICKFIX**, the instrument tips are interchangeable due to the M4 x 0.5 mm thread.

With the new **ZEPF** M5 Gracey curettes, instruments are presented in a new conception. The **Z-SHAPE** Relax handles **24.989.550X** were designed according to ergonomic knowledge for the optimal working process during the curettage. Both, the handle and the thin filigree surfaces are coated with the new **ZEPF nanopal**® coating.



## nanopal®



Adaption to the surface due to flexible shaft



Ideal grip and high cutting performance

































## Gracey M5 Prophylaxis Set

in **Z-SHAPE** or **BIONIK** handle  
with **ZEPF nanopal** coating

Small Instrument Set optimally compiled for Deep Scaling, consisting of  
M5 Gracey Curettes figures 1/2, 7/8, 11/12, 13/14 and a Sickle Scaler 204S  
for application in all quadrants.



<table border="0"> <tr> <td><math>\frac{3-1}{3-1} \mid \frac{1-3}{1-3}</math></td> <td></td> </tr> <tr> <td></td> <td></td> </tr> <tr> <td></td> <td>24.751.102GM5OX</td> </tr> <tr> <td></td> <td>GRA 1/2 M5, yellow</td> </tr> <tr> <td>24.751.101GM5OX</td> <td></td> </tr> </table>	$\frac{3-1}{3-1} \mid \frac{1-3}{1-3}$					24.751.102GM5OX		GRA 1/2 M5, yellow	24.751.101GM5OX		<table border="0"> <tr> <td><math>\frac{8-4}{8-4} \mid \frac{4-8}{4-8}</math></td> <td></td> </tr> <tr> <td></td> <td></td> </tr> <tr> <td></td> <td>24.751.108GM5OX</td> </tr> <tr> <td></td> <td>GRA 7/8 M5, champagne</td> </tr> <tr> <td>24.751.107GM5OX</td> <td></td> </tr> </table>	$\frac{8-4}{8-4} \mid \frac{4-8}{4-8}$					24.751.108GM5OX		GRA 7/8 M5, champagne	24.751.107GM5OX		<table border="0"> <tr> <td><math>\frac{8-4}{8-4} \mid \frac{4-8}{4-8}</math></td> <td></td> </tr> <tr> <td></td> <td></td> </tr> <tr> <td></td> <td>24.751.112GM5OX</td> </tr> <tr> <td></td> <td>GRA 11/12 M5, signal purple</td> </tr> <tr> <td>24.751.111GM5OX</td> <td></td> </tr> </table>	$\frac{8-4}{8-4} \mid \frac{4-8}{4-8}$					24.751.112GM5OX		GRA 11/12 M5, signal purple	24.751.111GM5OX		<table border="0"> <tr> <td><math>\frac{8-4}{8-4} \mid \frac{4-8}{4-8}</math></td> <td></td> </tr> <tr> <td></td> <td></td> </tr> <tr> <td></td> <td>24.751.114GM5OX</td> </tr> <tr> <td></td> <td>GRA 13/14 M5, cobalt-blue</td> </tr> <tr> <td>24.751.113GM5OX</td> <td></td> </tr> </table>	$\frac{8-4}{8-4} \mid \frac{4-8}{4-8}$					24.751.114GM5OX		GRA 13/14 M5, cobalt-blue	24.751.113GM5OX		<table border="0"> <tr> <td><math>\frac{8-6}{8-6} \mid \frac{6-8}{6-8}</math></td> <td></td> </tr> <tr> <td></td> <td></td> </tr> <tr> <td></td> <td>24.751.204ROX</td> </tr> <tr> <td></td> <td>Sickle Scaler # 204 S, yellow-green</td> </tr> <tr> <td>24.751.204LOX</td> <td></td> </tr> </table>	$\frac{8-6}{8-6} \mid \frac{6-8}{6-8}$					24.751.204ROX		Sickle Scaler # 204 S, yellow-green	24.751.204LOX	
$\frac{3-1}{3-1} \mid \frac{1-3}{1-3}$																																																						
																																																						
	24.751.102GM5OX																																																					
	GRA 1/2 M5, yellow																																																					
24.751.101GM5OX																																																						
$\frac{8-4}{8-4} \mid \frac{4-8}{4-8}$																																																						
																																																						
	24.751.108GM5OX																																																					
	GRA 7/8 M5, champagne																																																					
24.751.107GM5OX																																																						
$\frac{8-4}{8-4} \mid \frac{4-8}{4-8}$																																																						
																																																						
	24.751.112GM5OX																																																					
	GRA 11/12 M5, signal purple																																																					
24.751.111GM5OX																																																						
$\frac{8-4}{8-4} \mid \frac{4-8}{4-8}$																																																						
																																																						
	24.751.114GM5OX																																																					
	GRA 13/14 M5, cobalt-blue																																																					
24.751.113GM5OX																																																						
$\frac{8-6}{8-6} \mid \frac{6-8}{6-8}$																																																						
																																																						
	24.751.204ROX																																																					
	Sickle Scaler # 204 S, yellow-green																																																					
24.751.204LOX																																																						
<p>24.221.01GM5OX 24.201.01GM5OX BIONIK version</p>	<p>24.225.07GM5OX 24.205.07GM5OX BIONIK version</p>	<p>24.224.11GM5OX 24.204.11GM5OX BIONIK version</p>	<p>24.227.13GM5OX 24.207.13GM5OX BIONIK version</p>	<p>24.228.04SOX 24.208.04SOX BIONIK version</p>																																																		



Alternative Instruments:  
in **Z-SHAPE** or **BIONIK** handle  
with **ZEPF nanopal** coating

For the Gracey M5 Prophylaxis Set.  
**Sickle Scaler**, figure 204SD and  
**Sickle Curette** (Molar Scaler), figure M23A



5-1 | 1-5  
5-1 | 1-5

24.751.204RDOX



24.751.204LDOX



Sickle Scaler, # 204SD, for removing dental plaque from narrow interidental spaces in the premolar and frontal area, yellow-green

24.228.04SDOX

24.208.04SDOX

BIONIK version

8-1 | 1-8  
8-1 | 1-8

24.751.123ALOX



24.751.123AROX



Sickle Curette (Molar Scaler), # M23A for removing dental plaque from interidental spaces in the molar area. Also suitable for general use, yellow-green

24.228.23AOX

24.208.23AOX

BIONIK version

24.989.55OX

**ZEPF** Prophylaxis Set 'M5 Deep Scaling'  
in **Z-SHAPE RELAX** handle, complete  
with **nanopal** coating

24.990.55OX

**ZEPF** Prophylaxis Set 'M5 Deep Scaling'  
in **ZEPF BIONIK** handle, inserts  
with **nanopal** coating

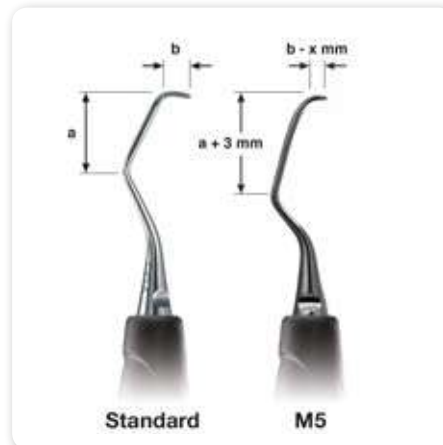

**HELMUT ZEPF** M5 Curettes have a 1st shaft which is about 3 mm longer. The sharpened instrument tip is shortened as to allow a special subgingival curettage for tight and deep pockets as well as narrow root surfaces.

Macro / Micro Needle Holder 

**ZEPF**-Line with SpinLock technology, lock and protected inner double spring, TC, made out of stainless steel.



41.200.17TC-K  
5/0 - 8/0

Needle Holder acc. to Dr. Kirsch TC



41.200.17TC-K 17.5 cm



41.201.17TC-K 17.5 cm



41.201.15TC  
4/0 - 8/0

Micro Needle Holder TC



41.200.15TC 16 cm

41.200.17TC 17.5 cm



41.201.15TC 16 cm

41.201.17TC 17.5 cm

Double-Action  
Micro Needle Holder



4/0 - 8/0

Micro Needle Holder



41.017.17 17.5 cm

Tungsten carbide,  
transmitted,  
**ZEPF**-Line, serrated,  
jaw width 0.6 mm.

## Micro Needle Holder **SpinLock**

**ZEPF-Line** with SpinLock technology, TC, serrated, lock, made out of stainless steel.



**41.010.17TC** straight, 17.5 cm

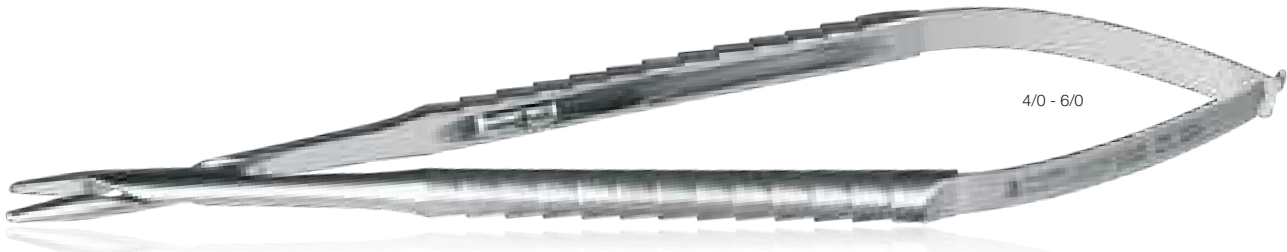

**41.010.17TC-M** Macro jaws, straight, 17.5 cm

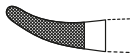

**41.011.17TC-M** Macro jaws, curved, 17.5 cm



**41.011.17TC** curved, 18 cm



**41.015.17** Hold'n'Cut acc. to PD Dr. Weng, combined with scissors, 17.5 cm

### **SpinLock** TECHNOLOGY BY HANAUER ZEPF What is the ZEPF SpinLock?

The parallel lock known from standard needle holders has been replaced with the new SpinLock technology. This avoids that the suture material gets caught up on the needle holder.



**onyx** ZEPF Micro Scissors  
DESIGN

Onyx-coated scissors offer a 3-5 times higher surface hardness. In combination with the "Supercut" grinding, this guarantees an extremely long product life and application as well as a very high precision and wear resistance. The extraordinary surface smoothness is leading to an easy slide of the scissor blades even under highest strain. Furthermore, the anti-glare surface avoids disturbing light deflections. The extremely smooth surface prevents adhesion of proteins.



**ZEPF-Line**, sharp / sharp, 45° angulated, 16 cm

**46.321.16** stainless steel

**46.321.16TISC** **onyx**



**ZEPF-Line**, sharp / sharp, curved, 17 cm

**46.319.17** stainless steel

**46.319.17TISC** **onyx**



1 Sectioning

**ZEPF Suture Removal Scissors** acc. to Dentist Beck, 17.5 cm

**ZEPF-Line**, with retaining function, micro-serrations, sharp / sharp, curved, SpinLock

**46.319.17N** stainless steel



2 Retaining





## ZEPF Micro Forceps



**Cooley**  
18 cm

**22.815.17** stainless steel



**Tissue Forceps**  
1 x 2 teeth, 17.5 cm

**22.810.17** stainless steel

**22.810.17D** 



**Dressing Forceps**  
smooth, 18 cm

**22.820.17** stainless steel

**22.820.17D** 

## New ZEPF Micro Tweezers

### The new Cooley Tweezers

The Cooley Micro Tweezers have a new bend to allow a better access to retromolar regions.

### The new Micro Suture Forceps

were more and more demanded for microsurgical purposes. When suturing, a safe soft tissue management is guaranteed with these forceps.



**22.823.17** **ZEPF** Micro Tweezers Cooley Special, 25° curved, long tips, for retromolar region



**22.814.17** **ZEPF** Micro Suture Forceps, smooth inner surfaces, outer Ø 2 mm, 18 cm



**ZEPF** Essentials Surgery Tray



**46.081.16SC** Joseph Scissors, curved, micro serrated, SuperCut, 14 cm



**41.200.17TC** Micro Needle Holder, ZEPF-Line, with lock & protected inner spring, SpinLock, stainless steel, 17.5 cm, TC



**22.489.00** Micro-Adson, 1 x 2 teeth, with suture plate, 15 cm



**46.007.02** Drop-Control Scalpel Blade Holder

PATENTED



**22.025.03** Tweezers, with stop-pin, ergonomic, 15 cm



**19.649.30** Surgical Aspirator, Ø 3 mm, curved, 17.5 cm





24.751.178

Back Action 90° | Dissector, blunt

24.751.512

41.854.20

41.854.10



24.751.520W

Papillex acc. to PD Dr. Weng | Scalpel, sharp, 4 mm

24.751.179

46.035.15

46.035.10



24.751.176 S

Spoon, 6 mm | Plugger, 5 mm

24.751.177

41.854.21

41.854.11



24.751.150

Prichard Spatula | Prichard Raspatory, 4 mm

24.751.126

41.854.22

41.854.12



41.751.012LU

Curette Lucas, 2.5 mm

41.751.011LU

41.855.22

41.855.20



24.751.123R

Universal Curette # M23

24.751.123L

$\frac{8-1}{8-1} \frac{1-8}{1-8}$

24.205.23

24.207.23



24.751.107HF

Hygienist, very fine version # H6 | # H7

24.751.106HF

$\frac{8-1}{8-1} \frac{1-8}{1-8}$

24.205.06HF

24.207.06HF

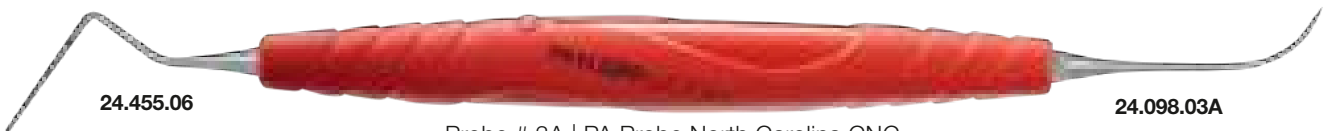

24.455.06

Probe # 3A | PA Probe North Carolina CNC

24.098.03A

24.854.24

24.854.14

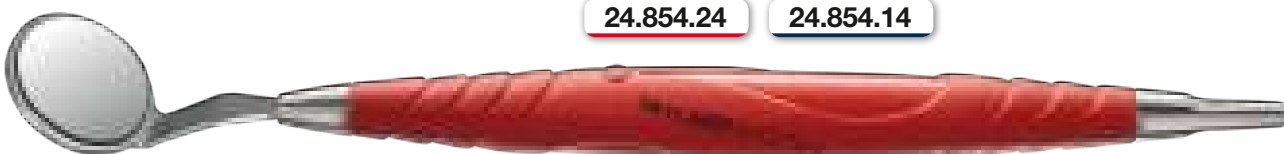

24.072.22.

MEGAduo Mouth Mirror Insert | **BIONIK** Universal Handle single-ended

26.194.05

26.194.07

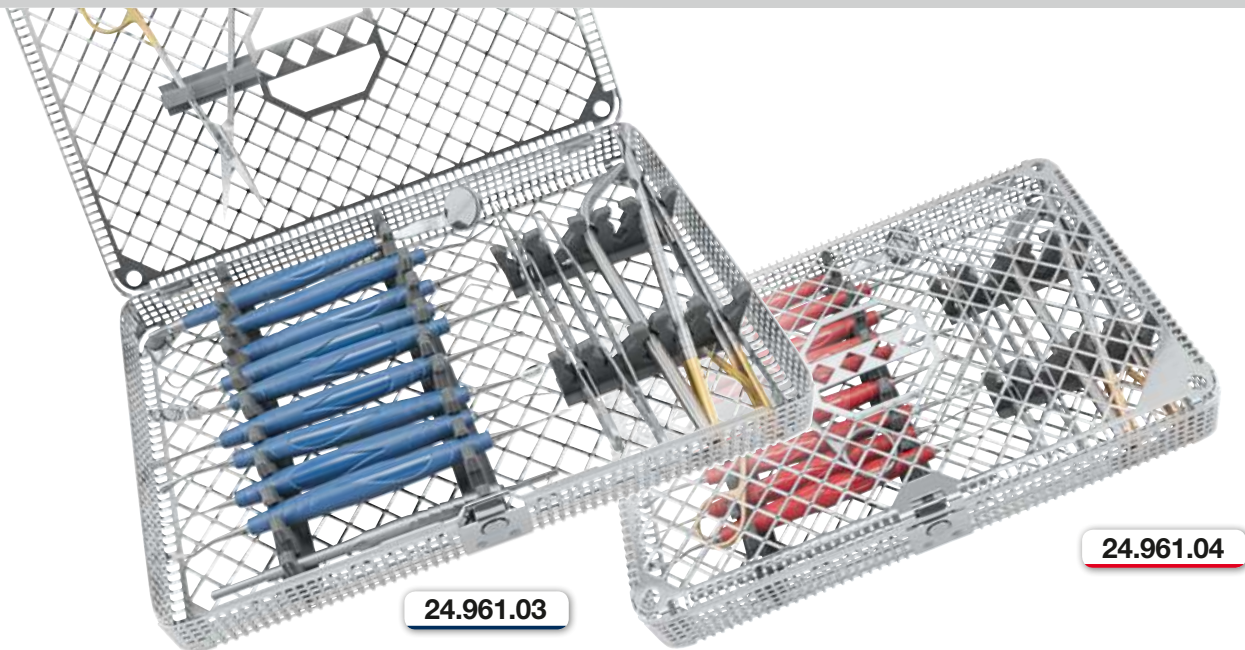

24.961.03

24.961.04

## ZEPF Essentials Surgery Tray

The **ZEPF** Essentials in cobalt-blue or lightred-magenta is a cost-efficient set compiled in many years of experience, leaving the practitioner nothing to be desired. All the oral surgical, implantological and periodontal aspects can be covered by this set.

The exchangeable working tips inserted in the ergonomic **BIONIK** handle offer highest economy and best tactile handling. Clearly organized in a washbasket – so everything is always easily at hand for the practitioner.

The **BIONIK** Universal Handle Instruments are available separately in **cobalt-blue** or **lightred-magenta**.



Art. No.	Art. No.	Description
41.854.20	41.854.10	Back Action 90°   Dissector, blunt
46.035.15	46.035.10	Papillex acc. to PD Dr. Weng   Scalpel, sharp, 4 mm
41.854.21	41.854.11	Spoon, 6 mm   Plugger, 5 mm
41.854.22	41.854.12	Prichard Spatula   Prichard Raspatory, 4 mm
24.072.22.	24.072.22.	MEGAduo Mouth Mirror Insert
26.194.05	26.194.07	<b>BIONIK</b> Universal Handle single-ended
41.855.22	41.855.20	Curette Lucas, 2.5 mm
24.205.23	24.207.23	Universal Curette # M23
24.205.06HF	24.207.06HF	Hygienist, very fine version # H6   # H7
24.854.24	24.854.14	Probe # 3A   PA Probe North Carolina CNC
41.200.17TC	41.200.17TC	Micro Needle Holder, <b>ZEPF</b> -Line, with lock & protected inner spring, SpinLock, stainless steel, 17.5 cm, TC
46.081.16SC	46.081.16SC	Joseph Scissors, curved, micro serrated, SuperCut, 14 cm
46.007.02	46.007.02	<b>ZEPF</b> Drop-Control® Scalpel Blade Holder
22.489.00	22.489.00	Micro-Adson, 1 x 2 teeth, with suture plate, 15 cm
22.025.03	22.025.03	Tweezers, with stop-pin, ergonomic, 15 cm
19.649.30	19.649.30	Surgical Aspirator, Ø 3 mm, curved, 17.5 cm

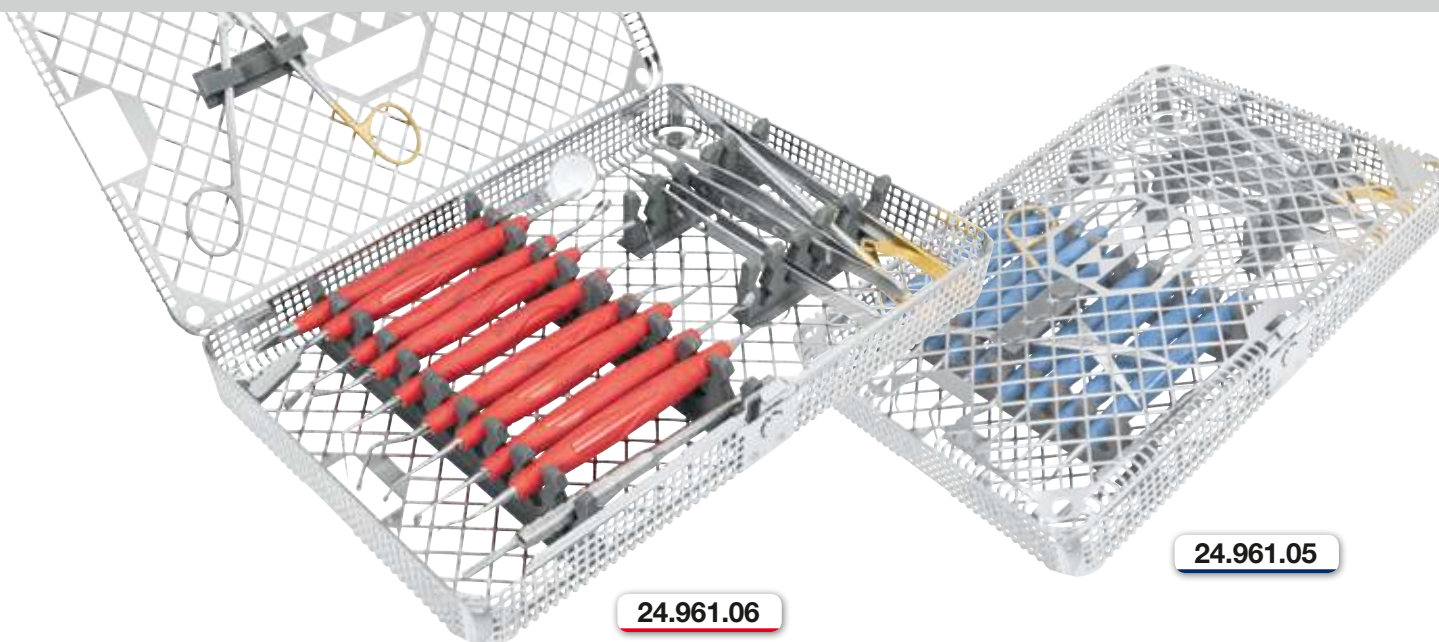

## ZEPF ECO ImplaTool Set

The **ZEPF ECO ImplaTool Set** in cobalt-blue (**26.961.05**) or lightred-magenta (**26.961.06**).

Out of his own experience Dr. Hildebrand came up with a complete instrument set for the whole oral surgery and the treatment in the implantology and periodontology. No matter if classical or new conceptions, like sinus elevation or microsurgical interventions, all demands can be covered. Special raspatories, elevators and dissecting instruments enable and simplify surgical procedures and mainly non-traumatic operations.

The exchangeable working tips inserted in the ergonomic **BIONIK** handle offer highest economy and best tactile handling. Clearly organized in a washbasket – so everything is always easily at hand for the practitioner.

The **BIONIK** Universal Handle Instruments are available separately in **cobalt-blue** or **lightred-magenta**.



Art. No.	Art. No.	Description
46.036.21	46.036.11	Dissector, blunt   Papillex
41.853.21	41.853.11	Back Action 90°   Scalpel, sharp, 4 mm
41.854.21	41.854.11	Plugger, 5 mm   Spoon, 6 mm
41.854.22	41.854.12	Prichard Raspatory, 4 mm   Prichard Spatula
24.072.22.	24.072.22.	MEGAduo Mouth Mirror Insert
26.194.05	26.194.07	<b>BIONIK</b> Universal Handle single-ended
41.855.22	41.855.20	Curette Lucas, 2.5 mm
41.854.23	41.854.13	Sinus Elevator, double-ended, acc. to Ho-Hi
24.205.06HF	24.207.06HF	Hygienist, very fine version # H6   # H7
24.853.24	24.853.14	Probe # 16   PA Probe North Carolina CNC
41.200.17TC	41.200.17TC	Micro Needle Holder, <b>ZEPF</b> -Line, with lock & protected inner spring, SpinLock, stainless steel, 17.5 cm, TC
46.081.16SC	46.081.16SC	Joseph Scissors curved, micro serrated, SuperCut, 14 cm
46.007.02	46.007.02	<b>ZEPF</b> Drop-Control® Scalpel Blade Holder
22.489.00	22.489.00	Micro-Adson, 1 x 2 teeth, with suture plate, 15 cm
22.025.03	22.025.03	Tweezers, with stop-pin, ergonomic, 15 cm

## Scalpel Blades

Supplied in packs of 100 pieces, sterile

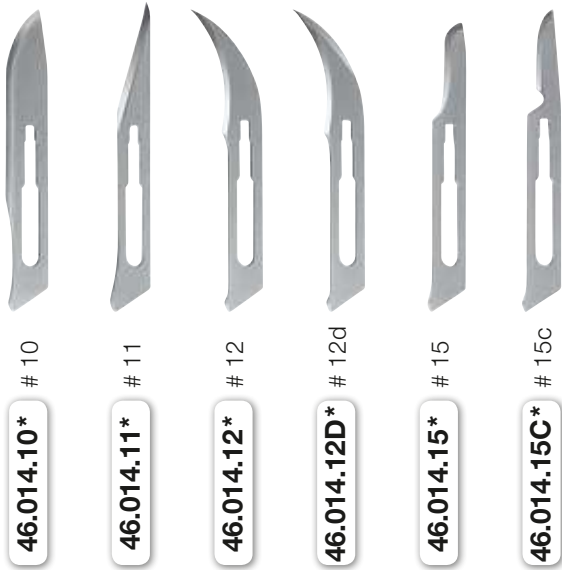

**46.014.10\*** # 10

**46.014.11\*** # 11

**46.014.12\*** # 12

**46.014.12D\*** # 12d

**46.014.15\*** # 15

**46.014.15C\*** # 15c

## Micro Surgical Scalpel Blades

Supplied in packs of 25 pieces, sterile

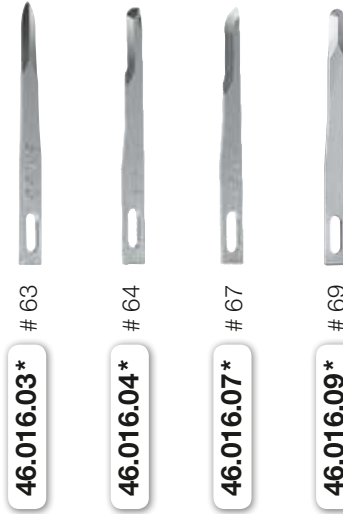

**46.016.03\*** # 63

**46.016.04\*** # 64

**46.016.07\*** # 67

**46.016.09\*** # 69



**46.007.00** Scalpel Handle **ZEPF-Line**, straight, for blades # 10 -15, 14.5 cm

**46.007.01** Scalpel Handle, **ZEPF-Line**, angled, for blades # 10 -15, 14.5 cm

**46.013.05Z** Scalpel Handle, titanium, **ZEPF-Line**, light weight, for blades # 10-15, 13.5 cm

**46.013.00Z** Micro Surgical Scalpel Handle, titanium, **ZEPF-Line**, 13.5 cm | **46.013.05** stainless steel

## ZEPF 3D-Blade Holder



### 3D-Blade Holder

Our **HELMUT ZEPF** 3D-Blade Holder will allow you to position blades easier than ever before! In designing this blade holder, particular attention was devoted to make it easy to use, clean and sterilize.

**46.007.05**

3D-Blade Holder Handle  
**ZEPF-Line**, 12.5 cm

**46.007.50**

Pivoted Head  
for 3D-Blade Holder, exchangeable,  
incl. Allen Key M2.5

**46.007.10**

3D-Blade Holder Handle  
with Pivoted Head, 12.5 cm





## ZEPF Drop-Control

### Blade Holder – new Design

As many customers asked for a heavier scalpel handle, we developed a new **ZEPF Drop-Control®** Blade Holder in the ergonomic BIONIK design.

With reference to the mechanism of a ball pen, **the blade will be dropped off by pushing the button at the end.**

The object of this development was a simplified application with the same diameter of the blade holder. Therefore there is no need to adapt to a new application / ergonomics for our regular blade holder!

The **ZEPF 'Drop-Control®'** Blade Holder perfectly fits into our **ZEPF Design** product range for surgery, implantology and microsurgery thanks to its diameter, design and ergonomics.

By pressing the button at the end of the blade holder the mechanism which lifts the blade is triggered off. The blade is pushed forward so that it falls safely and controlled in a tray or cup.

Afterwards the one-hand ejection function moves back in its initial position. After cleaning and sterilization you can insert a new blade – as usual.

The advantage lies in the fact that the used blade can be removed in a safe and controllable way in order to prevent a contaminated injury or infection.



Patent No.: 10 2014 101 658

46.007.08

Drop-Control® Scalpel Blade Holder, new design

46.007.02

Drop-Control® Scalpel Blade Holder



**Benex® II** Extraction System and Basic Kit

acc. to Dr. med., med. dent. Benno Syfrig

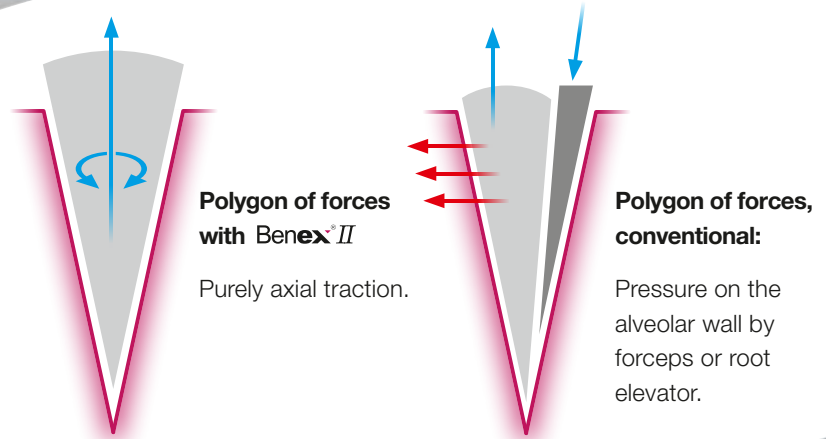
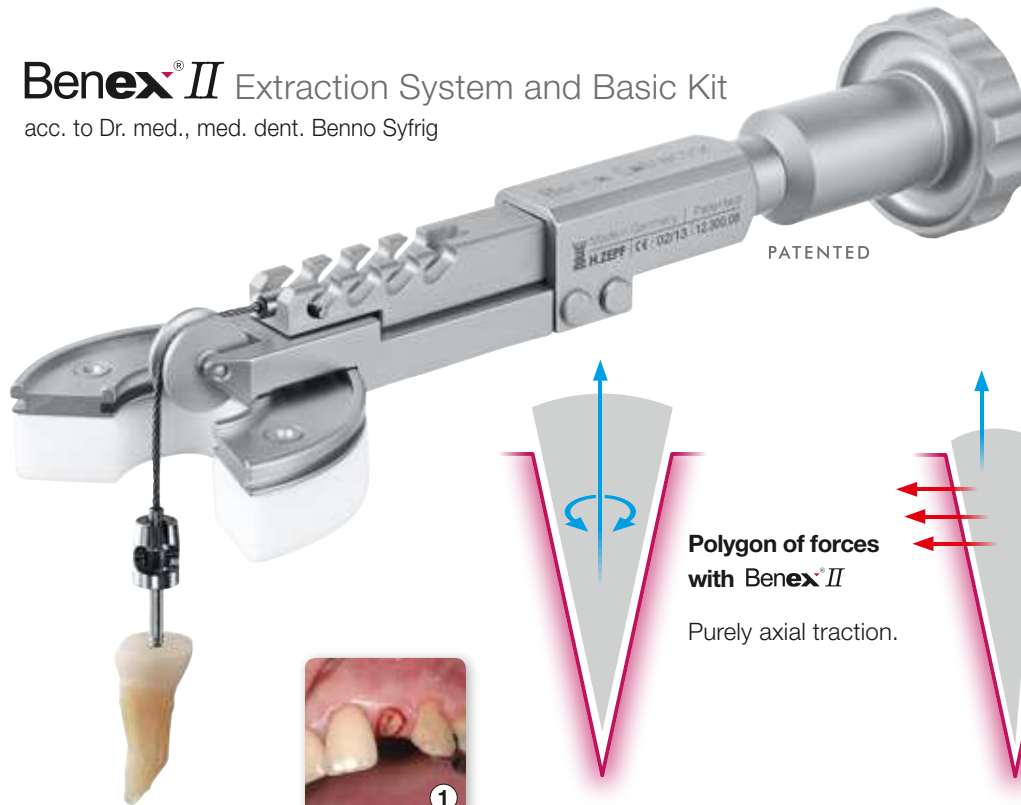

In modern dental treatment, implantology following extraction is increasingly favoured. Consistent with the principle of minimal invasion, conserving soft and hard tissue structures is a must. Starting with extraction.

The modified **Benex® II** guarantees a gentle and simple extraction of roots in the whole mouth. It is nearly impossible to harm the soft tissue and the surrounding bone.

Due to the longitudinal extraction, **Benex® II** is an optimal basis for direct implantation. It is also a valuable help for retarded implantation after the extraction with the **Benex® II** system. Studies made after the use of **Benex® II** prove that the reossification of the extraction alveole is advancing optimally. This is a great advantage for the retarded implantation.

The new **Benex® II** is now available in a washbasket complying with the RKI guidelines. That way, the requirements of optimal cleanability and sterilization were taken into account.

You will find further information, application examples and the **Benex®** user forum at: [www.benex-dent.com](http://www.benex-dent.com)

Alveolar Ridge Preservation with **Benex® II**

Alveolar Ridge Preservation means the treatment of the dental alveolus after extraction. 3 months after the **Benex®** extraction you find a considerably better ridge relation than with conventional gentle extractions. The **Benex®** finds its successful application in both, private practices and universities. The **Benex®** has achieved an excellent status worldwide as basis for a subsequently successful implantation.

The new support for the dismantled **Benex®** System in a washbasket guarantees an optimal cleanability of **Benex®** in a washing machine or in an ultrasonic bath. All components can be fixed safely in the support. Upon cleaning, the system can be sterilized in assembled condition.



① Root fracture:  
Pivot tooth extracted



② Axial removal  
with Benex® II

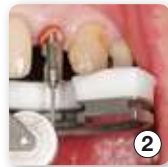

③ Soft and hard  
tissues preserved

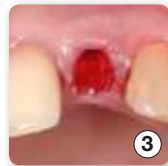

④ Soft tissue,  
12 weeks after  
extraction



⑤ Alveolar ridge,  
12 weeks after  
extraction

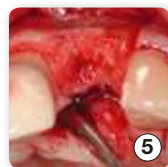



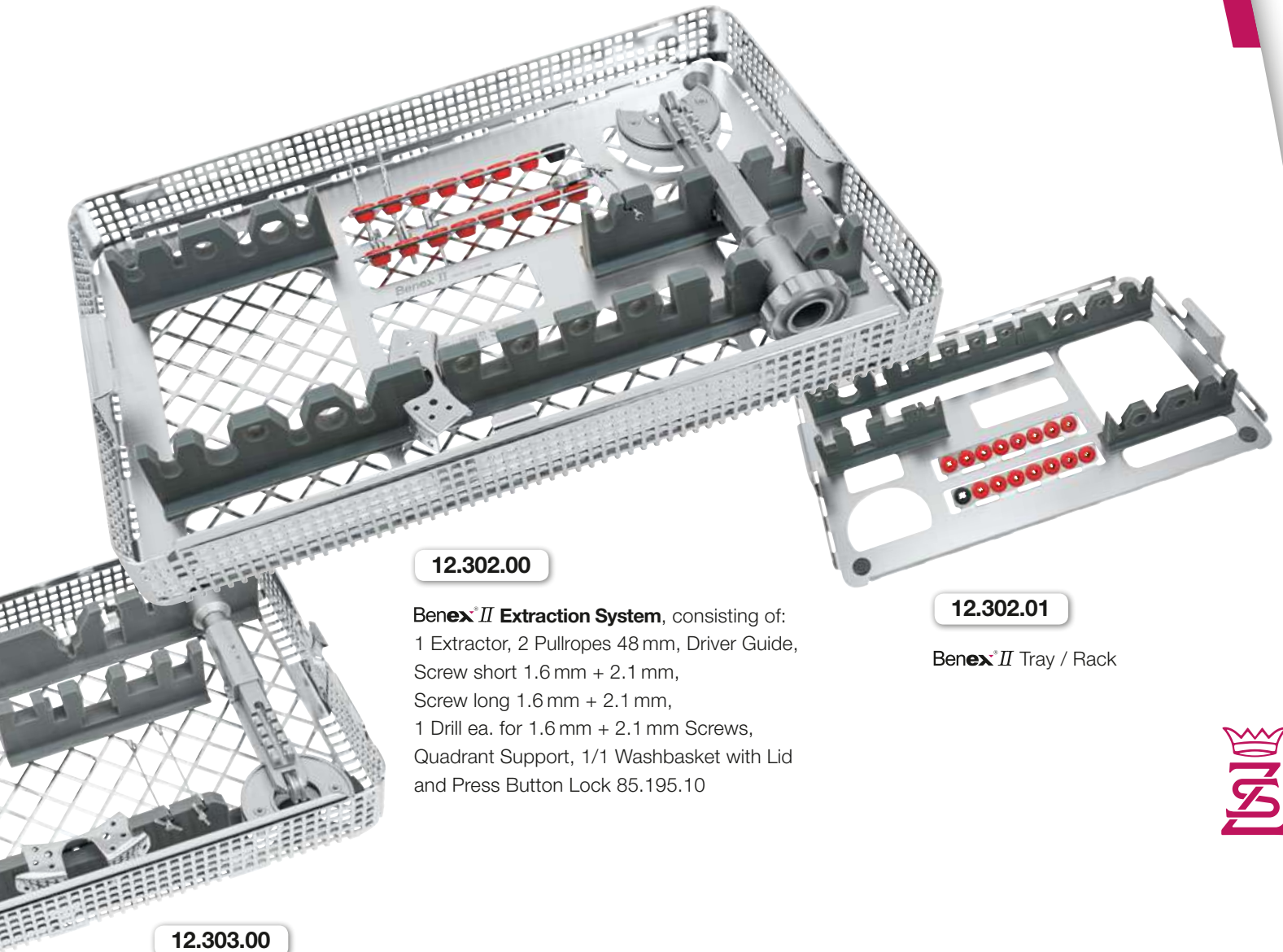

**12.302.00**

**Benex® II Extraction System**, consisting of:  
1 Extractor, 2 Pullropes 48 mm, Driver Guide,  
Screw short 1.6 mm + 2.1 mm,  
Screw long 1.6 mm + 2.1 mm,  
1 Drill ea. for 1.6 mm + 2.1 mm Screws,  
Quadrant Support, 1/1 Washbasket with Lid  
and Press Button Lock 85.195.10

**12.302.01**

**Benex® II Tray / Rack**

**12.303.00**

**Benex® II Basic Kit**, consisting of:  
1 Extractor, 2 Pullropes 48 mm, Driver Guide,  
Screw short 1.6 mm + 2.1 mm,  
Screw long 1.6 mm + 2.1 mm,  
1 Drill ea. for 1.6 mm + 2.1 mm Screws,  
Quadrant Support, 1/1 Washbasket with Lid  
and Press Button Lock 85.194.10



**Benex® II Pole Extractor**

The patentet supplement

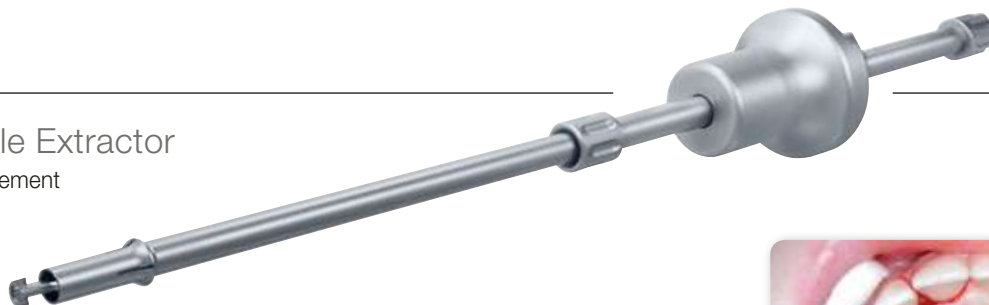

**12.300.11**

**Benex® Pole Extractor**

For roots with a strong decline to the occlusion level and/or inappropriate access for the positioning of the **Benex®** extractor.  
For poorly anchored root/tooth fragments.



## Benex® II The individual components

acc. to Dr. med., med. dent. Benno Syfrig

FURTHER QUESTIONS?  
[www.benex-dent.com](http://www.benex-dent.com)



**12.300.08**

**Benex® II Extractor**  
acc. to Dr. med., med. dent.  
Benno Syfrig incl.  
Support Disc

**12.302.00** Benex® II Extraction System

**12.303.00** Benex® II Basic Kit

Apart from the Washbasket 1/1 with Lid and Press Button Lock (**85.195.10**)  
incl. the Benex II Tray / Rack (12.302.01) for the Extraction System and  
the Washtray 1/2 with Lid and Press Button Lock (**85.194.10**) for the Basic Kit,  
the following components are included in both Sets (pict. scale 1:1):



**12.300.15**

Replacement Support  
Disc, 8 mm (PTFE)



**12.300.20**

Pullrope, 48 mm,  
PU: 2 pieces



**12.300.47**

Driver Guide, short



**12.300.60**

1 Screw 10 mm  
Ø 1.6 mm, S = Short



**12.300.65**

1 Screw 10 mm  
Ø 2.1 mm, SF = Short & Fat



**12.300.30**

1 Diamond coated Drill  
for Screws Ø 1.6 mm  
12.300.60 and 12.300.70



**12.300.70**

1 Screw 16 mm  
Ø 1.6 mm, L = Long



**12.300.75**

1 Screw 16 mm  
Ø 2.1 mm, LF = Long & Fat



**12.300.35**

1 Diamond coated Drill  
for Screws Ø 2.1 mm  
12.300.65 and 12.300.75



**12.300.80**

Quadrant Support  
to bridgeover bigger gaps  
and for universal molding

### OPTIONALLY AVAILABLE



**12.300.17**

Support Disc,  
diagonally left



**12.300.16**

Support Disc,  
diagonally right



**12.300.45**

Blade for

**47.525.51**

Driver Guide FD

## ZEPF FLEX-EX Power Periotome



While using new materials, we were successful in the development of the **ZEPF FLEX-EX** Power Periotome, a symbiosis of Power Periotome, Elevator and Xtool. The flexible working tip will enable you to build up a phenomenal pressure for the luxation in a radial direction and a perfect match to the contour of the tooth at the same time without bending. The name stands for the excellent product features united in this instrument.

## ZEPF Power Periotomes

The Power Periotomes allow a gentle loosening of ligaments in the sulcus. The handle allows optimal power transmission and controlled luxation.

**26.690.01** Power Periotome, P1 XL, purple



**26.690.02** Power Periotome, P2 XL, mesial, blue



**26.690.03** Power Periotome, P3 XL, distal, green



**ZEPF**  
**roba**  
EDITION  
PATENTED

With the patented RoBa-Edition **HELMUT ZEPF** introduces a new generation of extracting forceps. Deduced from the **ZEPF Xis(s)** Instruments the RoBa-Edition has been especially developed in consideration of easy and gentle extraction.

The patented RoBa-Edition according to Dentist Beck is the consequential advancement of conventional extracting forceps with the advantages of the tapered deep-grip extracting forceps. The modified beaks according to Dentist Beck fit exactly on the teeth which ensures a maximum grip in the appliance. These new beaks are available for all figures in upper and lower jaw (incisors, premolars, molars and wisdom teeth).

Due to the fact that all teeth show a convex crown contour (upper jaw: labial, buccal, palatal and in lower jaw: labial, buccal, lingual), the beaks have been developed under this anatomical actuality. The wear-resistant Teflon Disc eliminates wear and tear in the joints and provides a light action at all times. The handle is a protected design from **HELMUT ZEPF**, which was developed in cooperation with Dr. Maty, Germany.

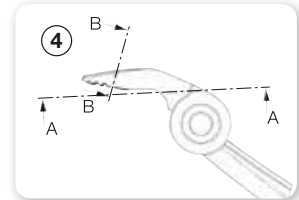
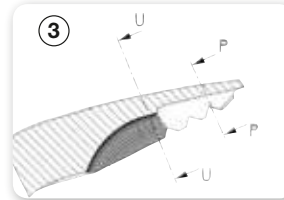
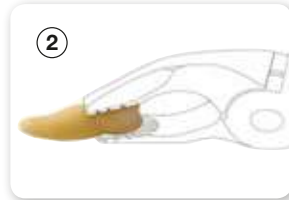
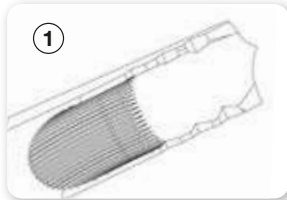

The billow-grind claws radially into the teeth and avoids a "riding" in-between the tooth crown and the inner contour of the beak.

Concavely elaborated inner contours of the forceps beak fit in the convex tooth contour. With deep grip in the alveolus or on the crown, the RoBa Edition ensures a parallel and maximum grip in any situation. Root fracture almost can be excluded.

The different deeply elaborated inner contours ensure maximal adaptation on the teeth in different actualities. No tilting of the teeth while rotary and/or lifting movement.

Tapered outside contour of the beak affords deep grip even subgingival.

scale 1:1							
	3.2.1.   1.2.3.	5.4.   4.5.	5.4.   4.5.	7.6.	6.7.	8.   8.	8.
	<b>12.234.08Z</b>	<b>12.235.07Z</b>	<b>12.235.08Z</b>	<b>12.217.00Z</b>	<b>12.218.00Z</b>	<b>12.267.01Z</b>	<b>12.279.90Z</b>
	<b>12.234.08ZD</b>	<b>12.235.07ZD</b>	<b>12.235.08ZD</b>	<b>12.217.00ZD</b>	<b>12.218.00ZD</b>	<b>12.267.01ZD</b>	<b>12.279.90ZD</b>
	<b>12.234.08ZTI</b>	<b>12.235.07ZTI</b>	<b>12.235.08ZTI</b>	<b>12.217.00ZTI</b>	<b>12.218.00ZTI</b>	<b>12.267.01ZTI</b>	<b>12.279.90ZTI</b>





12.234.07ZTI (scale 1:1)

**onyx** DESIGN Black Finish Coating

**Design meets functionality.** Users with highest demands will appreciate the elegant, black finish providing the instrument with a non-reflecting, extremely smooth and scratch-resistant surface. The article number is complemented by **TI**.



3.2.1. | 1.2.3.

12.234.07Z

12.234.07ZD

12.234.07ZTI



12.234.07ZD (scale 1:1)



Diamond Version

All RoBa-Edition extracting forceps in the classic satin-metallic finished surface are available with diamond coating for a better grip. The lower part of the **ZEPF Precision** Handle is gold-plated. For ordering etc., just add to the item number the letter **D**.

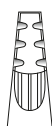

3.2.1. | 1.2.3.

12.236.07Z

12.236.07ZD

12.236.07ZTI

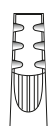

3.2.1. | 1.2.3.

12.236.08Z

12.236.08ZD

12.236.08ZTI

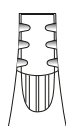

5.4. | 4.5.

12.213.00Z

12.213.00ZD

12.213.00ZTI

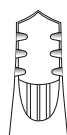

7.6. | 6.7.

12.222.00Z

12.222.00ZD

12.222.00ZTI

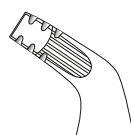

7.6. | 6.7.

12.221.90Z

12.221.90ZD

12.221.90ZTI



W

12.045.15ZS

12.045.15ZD

12.045.15ZTI

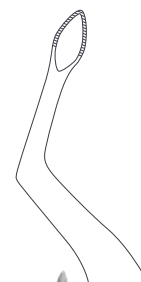

W

12.051.15ZS

12.051.15ZD

12.051.15ZTI

scale 1:1

Rescue-Line

Rescue-Line



## ZEPF EXLOG RoBa Edition Extracting Forceps

With the new **exLOG** RoBa Edition **ZEPF** introduces a new generation of patented extraction forceps. Two patented extraction forceps are combined into one.

The EXLOG Forceps characterized by the fact that they are easy to disassemble and the RoBa characterized by their patented jaws.

It made sense to combine both patents as the combination results in a type of forceps which is easier to clean than ever before and additionally offers the dentist a functional extraction tool which leaves no desire unfulfilled.

These patented forceps are the consequent development of conventional forceps with the advantage of tapered and deep grip extraction forceps.

### All Advantages on One View:

- excellent anatomical adaption on the neck of the tooth surface
- tapered jaws for less traumatization and for conservation of the alveolus
- better fiber dilatibility and increased sense of touch
- optimal cleaning due to the possibility to disassemble the forceps into two pieces (RKI compliant)
- long life time, patented, high precision joint for radial and axial pressure
- produced from one piece (5-axis CNC milling) and therefore ultra precise
- no maintenance of the joint

Focus on the **exLOG**, the standard of tomorrow.



scale 1:1						
	3.2.1.   1.2.3.	3.2.1.   1.2.3.	5.4.   4.5.	5.4.   4.5.	7.6.	6.7.
	<b>15.234.07</b>	<b>15.234.08</b>	<b>15.235.07</b>	<b>15.235.08</b>	<b>15.217.00</b>	<b>15.218.00</b>
	<b>15.234.07D</b>	<b>15.234.08D</b>	<b>15.235.07D</b>	<b>15.235.08D</b>	<b>15.217.00D</b>	<b>15.218.00D</b>
	# 34N	# 34M	# 35N	# 35M	# 17	# 18

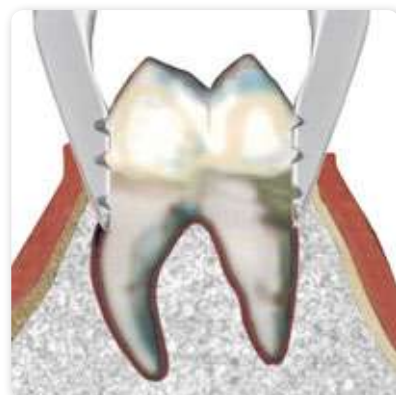

**The patented demountability of EXLOG forceps**



**The following problems might occur if the extraction forceps are not suitable:**

- root fracture
- crown fracture
- damage of the soft tissue caused by bruising
- damage of the alveolar ridge and the buccal bone lamella

**Advantages of deep-grip extraction forceps:**

- due to the specially shaped jaws it is easy to place the forceps subgingivally directly on the root (below the gingival margin)
- parallel contact on the root
- atraumatic, as the soft tissue is not bruised
- root fractures are avoided
- slim jaw design for subgingival grip without bruise of the soft tissues

3.2.1.   1.2.3.	3.2.1.   1.2.3.	5.4.   4.5.	7.6.   6.7.	8.   8.	8.   8.
<b>15.236.07</b>	<b>15.236.08</b>	<b>15.213.00</b>	<b>15.222.00</b>	<b>15.267.01</b>	<b>15.279.90</b>
<b>15.236.07D</b>	<b>15.236.08D</b>	<b>15.213.00D</b>	<b>15.222.00D</b>	<b>15.267.01D</b>	<b>15.279.90D</b>
# 36N	# 36M	# 13	# 22	# 67A	# 79A



**Children Forceps** RoBa-Edition

Extracting Forceps modif. acc. to Dentist Beck

These deciduous teeth extraction forceps have been designed to be as small as possible in order to avoid frightening younger patients with large, aggressive-looking instruments, thereby providing relaxed working conditions.

The patented Deciduous Teeth RoBa-Edition Forceps according to Dentist Beck are the consequential advancement of conventional extracting forceps with the advantages of the tapered deep-grip extracting forceps. The modified beaks according to Dentist Beck fit exactly onto the teeth which ensures a maximum grip during the appliance.

**ZEPF**  
**roba**  
EDITION  
PATENTED



2.1 | 1.2.

**10.685.29**

# 29

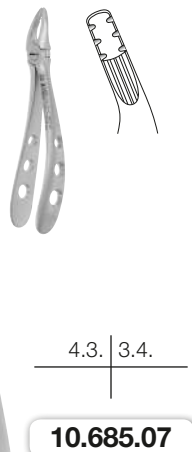

4.3 | 3.4.

**10.685.07**

# 7



2.1 | 1.2.

**10.685.33**

# 33



4.3 | 3.4.

**10.685.13**

# 13



5. | 5.

**10.685.22**

# 22

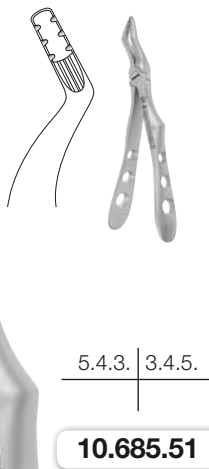

5.4.3. | 3.4.5.

**10.685.51**

# 51



5. | 5.

**10.685.52**

# 52

The wear-resistant Teflon® disc eliminates wear and tear in the joints and provides a light action at all times.

## Modified Root Elevator acc. to Dentist Beck

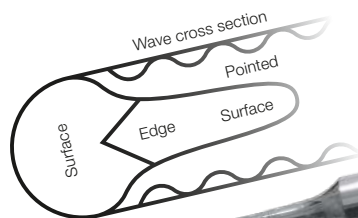

### Instructions



Because of the elliptical shape of the instrument tip, it is easy to penetrate the interdental space with this instrument.



Due to the shape, by turning the instrument through 180° it is possible to luxate in four directions: 2x mesially and 2x distally.



**Attention!** These instruments must not be used as a lever, as shown e.g. in picture 3. Due to the special shape, an over-strengthening of the tip can cause breakage. We cannot be held responsible for damages caused by improper use.

The elevator works during the luxation step with 5-7 supporting points (hypomochlion), which avoids slipping through because of the different surfaces around the radius, instead of a common round-edged instrument, which works with 1-2 supporting points only. This makes the Beck Root Elevator much more effective.



## Apical Root Elevator

Root elevator for wisdom teeth. For all molars, especially for **unimpacted** wisdom teeth in all 4 quadrants.



**17.677.16** Apical Root Elevator, # 77R, ideal for wisdom teeth

**17.677.17** Apical Root Elevator, # 77, ideal for wisdom teeth



## Root Elevators

**Use.** Root elevators are used for the surgical tooth extractions. They are used to luxate the tooth in the osseous alveolus and to expand the alveolus walls. They are also used to open the gingival sulcus prior to the tooth extraction.

**Application.** Straight instruments are used in the anterior region and in the maxillary area. Curved root elevators are ideal for the back teeth in the mandible.

**Workmanship.** The shafts of **HELMUT ZEPF** Root Elevators are welded onto their hollow handles, and each and every one is checked for leakage at their welded joints. This manufacturing method virtually eliminates the leakage compared to cheap root elevators with pressed-in shafts.

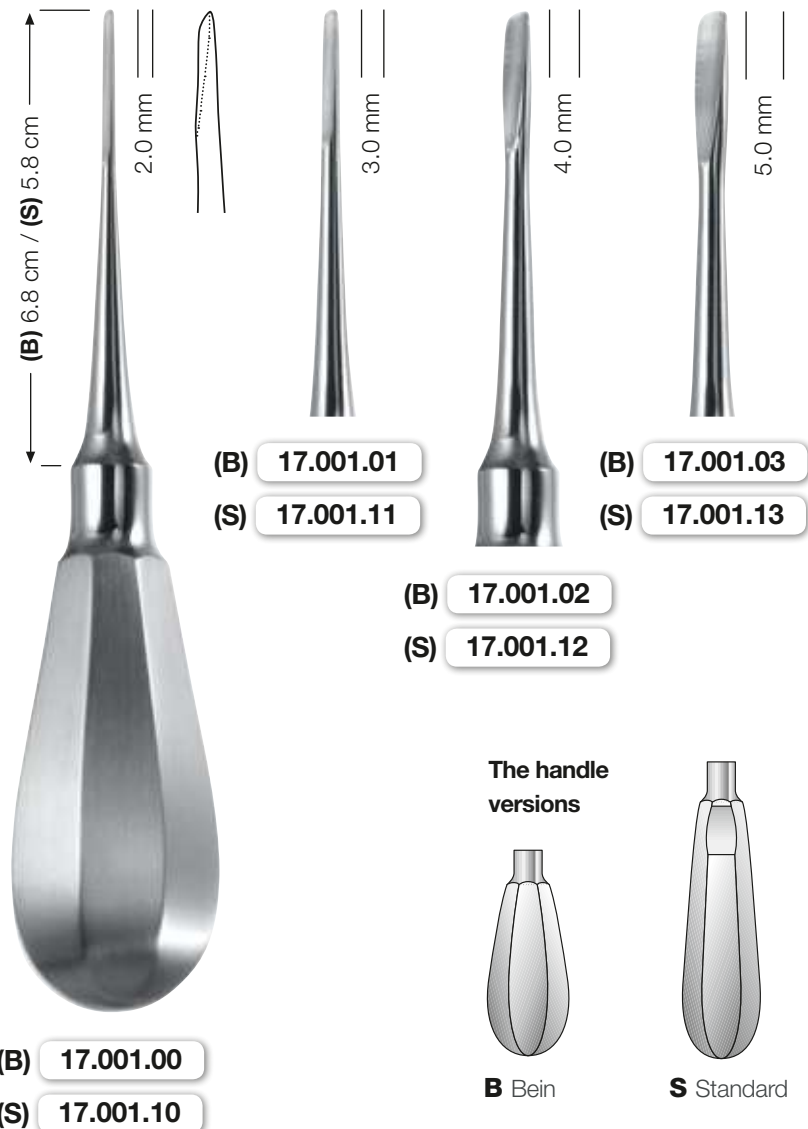

## Root Elevators Cryer

Claw elevators are ideal to extract molars in the mandible after separation of the roots.

The bend of the working ends, combined with the shortened tips, allows a gentle lifting of the opposite root without contact to the neighboring crown.

The special claw elevators are ideal to luxate roots if an apical access is possible from the neighboring alveolus, e.g. if a root has already been removed and if the empty alveolus can be used as access. It is recommended first to remove the root which is bent less.

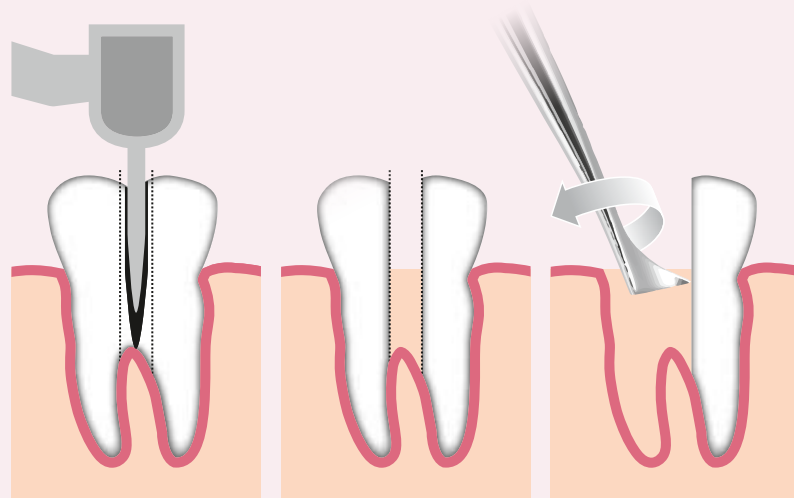

### Gärtner Root Elevators



### Elevators for axial luxation

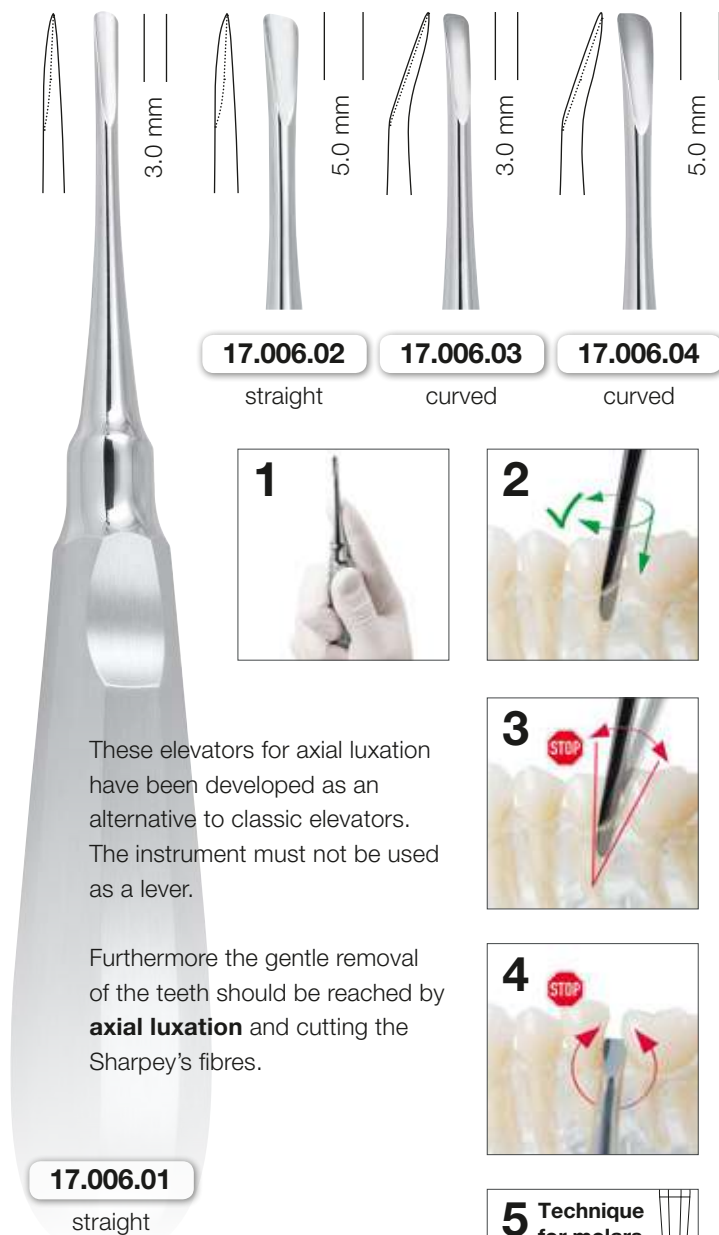

These elevators for axial luxation have been developed as an alternative to classic elevators. The instrument must not be used as a lever.

Furthermore the gentle removal of the teeth should be reached by **axial luxation** and cutting the Sharpey's fibres.

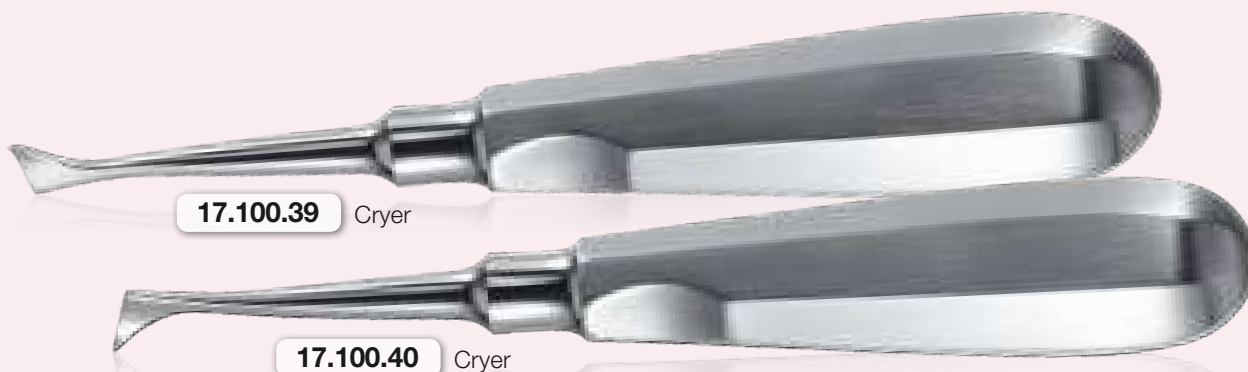



# THE ORIGINAL

**“Extraction in its most pleasant way”**

The **ZEPF-Xtody-Tray** offers a universal instrument set  
(**17.007.00**) for medical tooth extraction.

The **Xtody** instrumentation includes six different instruments:

With **onyx** DESIGN Black Finish Coating

**Design meets functionality.** Users with highest demands will appreciate the elegant, black finish providing the instrument with a non-reflecting, extremely smooth and scratch-resistant surface.

The article number is complemented by **TI**.

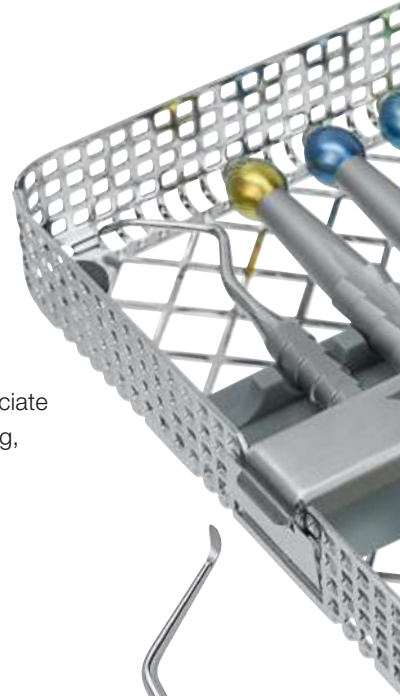

17.007.01



17.007.01TI

**X-Luxa-Tool**, straight, 2.5 mm, for front teeth and upper jaw, green metallic



17.007.02



17.007.02TI

**X-Luxa-Tool**, straight, 4.5 mm, for front teeth and upper jaw, green metallic



17.007.03



17.007.03TI

**X-Luxa-Tool**, curved, 2.5 mm, for lower jaw, blue metallic



Lucas Scraper, 2.5 mm, double-ended, 17.5 cm

41.855.01Z

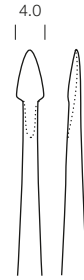
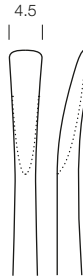
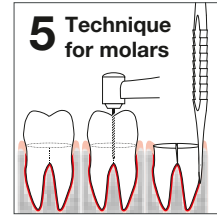
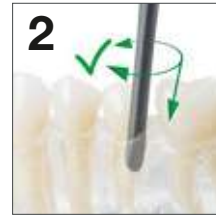
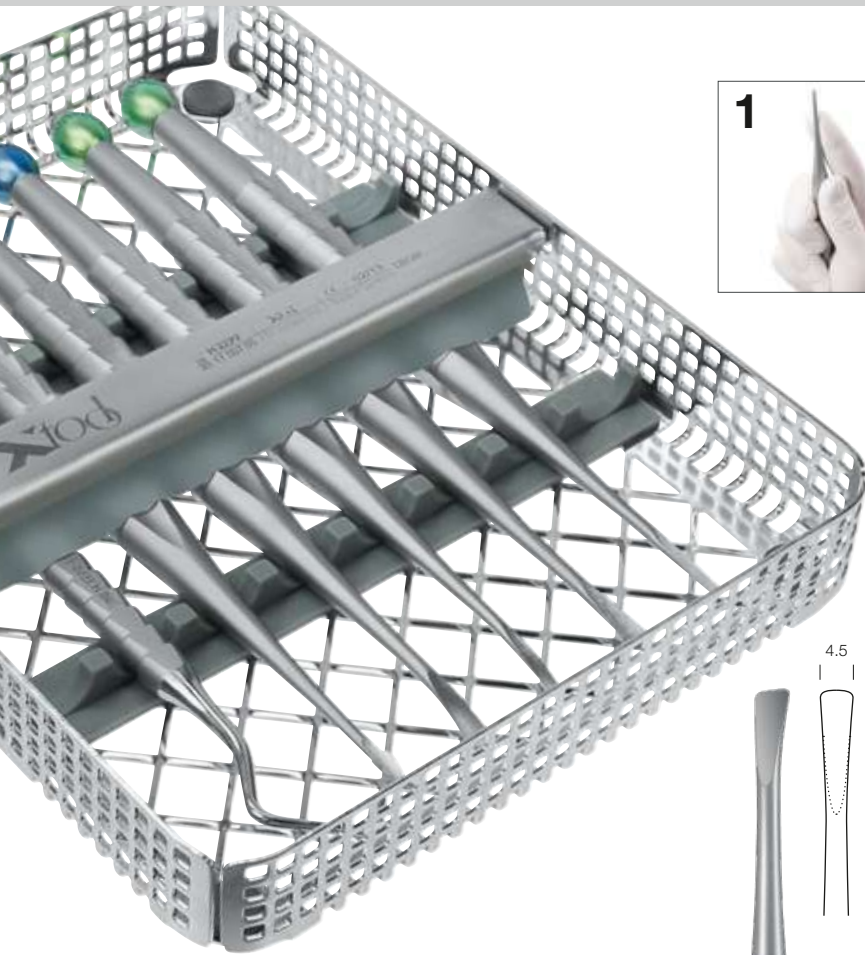

17.007.00

Xtools Kit  
consisting of 5 Xtools (17.007.01,  
17.007.02, 17.007.03, 17.007.04,  
17.007.05) and Lucas Scraper  
(41.855.01Z), in a washtray 1/2  
(85.181.00)

17.007.00TI

Xtools Kit  
onyx version



17.007.04



17.007.04TI

X-Luxa-Tool, curved, 4.5 mm, for lower jaw, blue metallic



17.007.05



17.007.05TI

X-Desmo-Tool, straight, 4.0 mm, for initial loosening of the desmodontal fibres, yellow metallic







# THE ORIGINAL

## Modern therapy methods require modern instruments!

All instruments are also available with **onyx** Black Finish Coating (see page 40/41). The respective article numbers are supplemented by **TI**.

- Color coding for clear handling.
- Universal and complete extraction instruments (in one tray).
- Direct and controlled power transmission to prevent tooth and root fractures.
- Ergonomic handle design (pencil-design) prevents unintended slipping during usage.
- Non-traumatic tooth extraction without injuring surrounding structures.

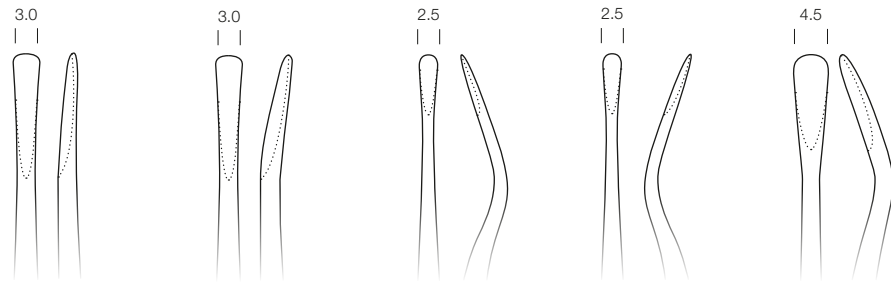

X-Luxa-Tool, straight, 3.0 mm, green metallic

17.007.06

17.007.06TI



X-Luxa-Tool, curved, 3.0 mm, blue metallic

17.007.07

17.007.07TI



X-Approximal Root Elevator, curved, 2.5 mm, # 77S, distal elevator, purple metallic

17.008.01

17.008.01TI



X-Approximal Root Elevator, curved, 2.5 mm, # 77RS, mesial elevator, purple metallic

17.008.02

17.008.02TI



X-Approximal Root Elevator, curved, 4.5 mm, # 77L, distal elevator, yellow metallic

17.008.03

17.008.03TI



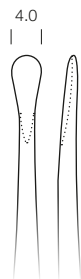
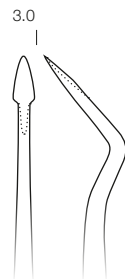
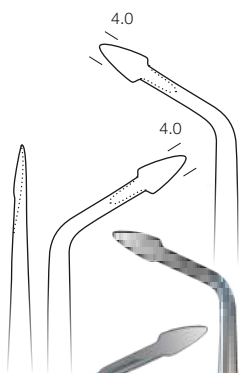
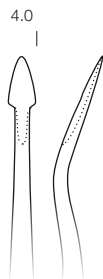
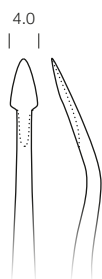
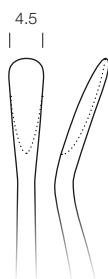

X-Approximal Root Elevator, curved, 4.5 mm, # 77RL, mesial elevator, yellow metallic



X-Syndesmotome, curved, 4.0 mm, for distal access, purple metallic



X-Syndesmotome, curved, 4.0 mm, for mesial access, purple metallic



X-Syndesmotome, curved left, 4.0 mm, for lingual/buccal luxation, yellow metallic

X-Syndesmotome, curved right, 4.0 mm, for lingual/buccal luxation, yellow metallic



X-Apical Desmotome, mesial bending, 3.0 mm, for apical access to the deep-lying root stump, brown metallic



X-Apical Elevator, mesial bending, 2.5 mm, for apical access to the deep-lying root stump, brown metallic



X-Separator, straight, 4.0 mm, for the luxation of separated roots, purple metallic

17.008.04

17.008.05

17.008.06

17.008.08/09

17.008.10

17.008.11

17.008.90

17.008.04TI

17.008.05TI

17.008.06TI

17.008.08/09TI

17.008.10TI

17.008.11TI

17.008.90TI





acc. to Dr. Detlef Hildebrand

## New Xtool Kits

**17.007.70**

**Xtool** Elevator Kit "small" consisting of 4 Xtools (17.007.01/03, 17.008.01/02) and Arkansas Sharpening Stone (24.923.10), in a washtray 1/3

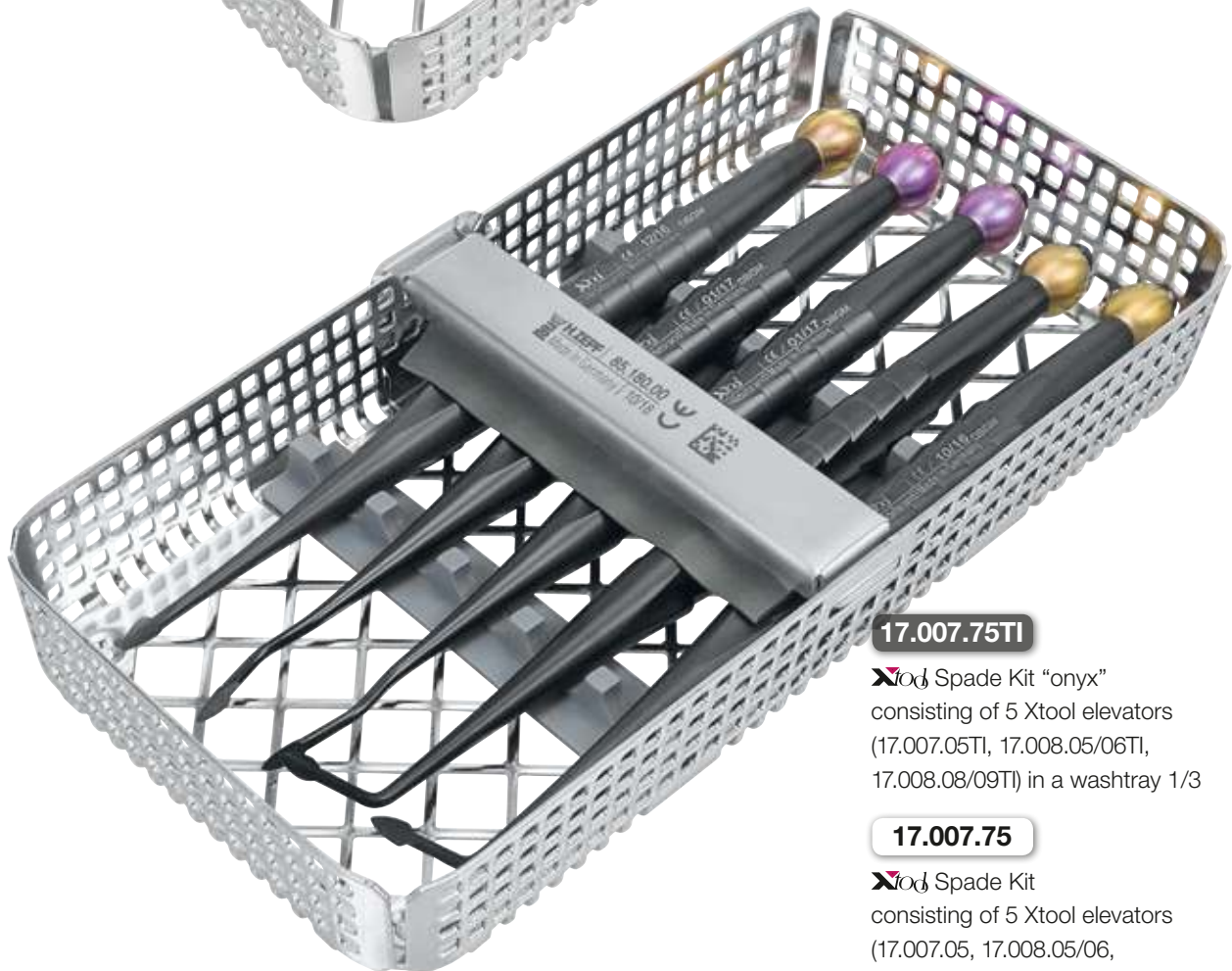
**17.007.75TI**

**Xtool** Spade Kit "onyx" consisting of 5 Xtool elevators (17.007.05TI, 17.008.05/06TI, 17.008.08/09TI) in a washtray 1/3

**17.007.75**

**Xtool** Spade Kit consisting of 5 Xtool elevators (17.007.05, 17.008.05/06, 17.008.08/09) in a washtray 1/3



## Xtob Instruments

with serration acc. to Lindo-Levien

In modern dentistry, implantology with immediate insertion after tooth removal is increasingly becoming the focus of attention. In order to follow the principle of minimal invasiveness, it is imperative to preserve the surrounding hard and soft tissue as much as possible during extraction.

For this purpose, we have supplemented our Xtob range by 4 modified instruments that have an additional Lindo-Levien serration.

The fine Lindo-Levien serration enables the Xtob instrument to be fixed to the tooth root in a non-slip manner, thus facilitating extraction of the tooth by means of a counteracting force without leverage.



For cleaning the alveolus after extraction we recommend our Lucas curettes. The serrated Lucas curettes support a safe treatment in the field of cyst removal.

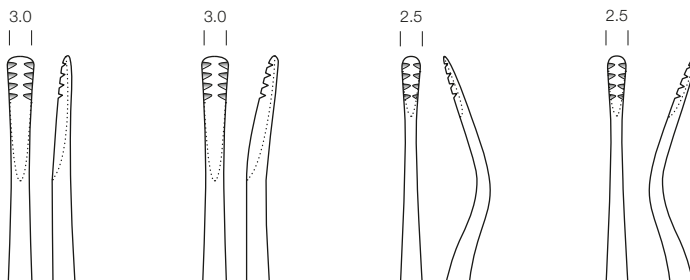

Xtob-Luxa-Tool 6 Elevator, acc. to Lindo-Levien, straight, 3.0 mm, green metallic



Xtob-Luxa-Tool 7 Elevator, acc. to Lindo-Levien, curved, 3.0 mm, blue metallic



Xtob-Approximal Root Elevator, acc. to Lindo-Levien, curved, 2.5 mm, # 77S, distal elevator, purple metallic



Xtob-Approximal Root Elevator, acc. to Lindo-Levien, curved, 2.5 mm, # 77RS, mesial elevator, purple metallic



THE ORIGINAL

straight

curved

curved

curved

17.007.06LL

17.007.07LL

17.008.01LL

17.008.02LL

## H-Tool Set

acc. to Dr. Hildebrand

The new H-Tools developed by Dr. Hildebrand are a continuation of the successful X-Tool concept. The instrument tips are very flat and sharp pointed. The instruments are inserted along the root axis and the alveolar cavity is widened by advancing the H-Tool apically along the root of the tooth to be extracted with gentle hammer blows.

The light Ferrozell Hammer with a diameter of 35 mm enables work to be carried out safely. Thanks to the extremely light construction, this hammer produces a far less unpleasant feeling in the patient than using a hammer with hard plastic inserts or in the worst case with a metal head.

scale 1:1

**41.503.01**

Hammer, Ferrozell,  
head Ø 35 mm, 100 g,  
total weight 180 g,  
250 mm long,  
fitting washbasket

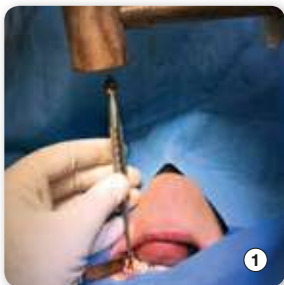

1



2

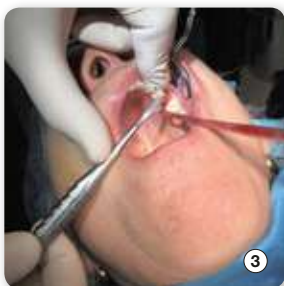

3

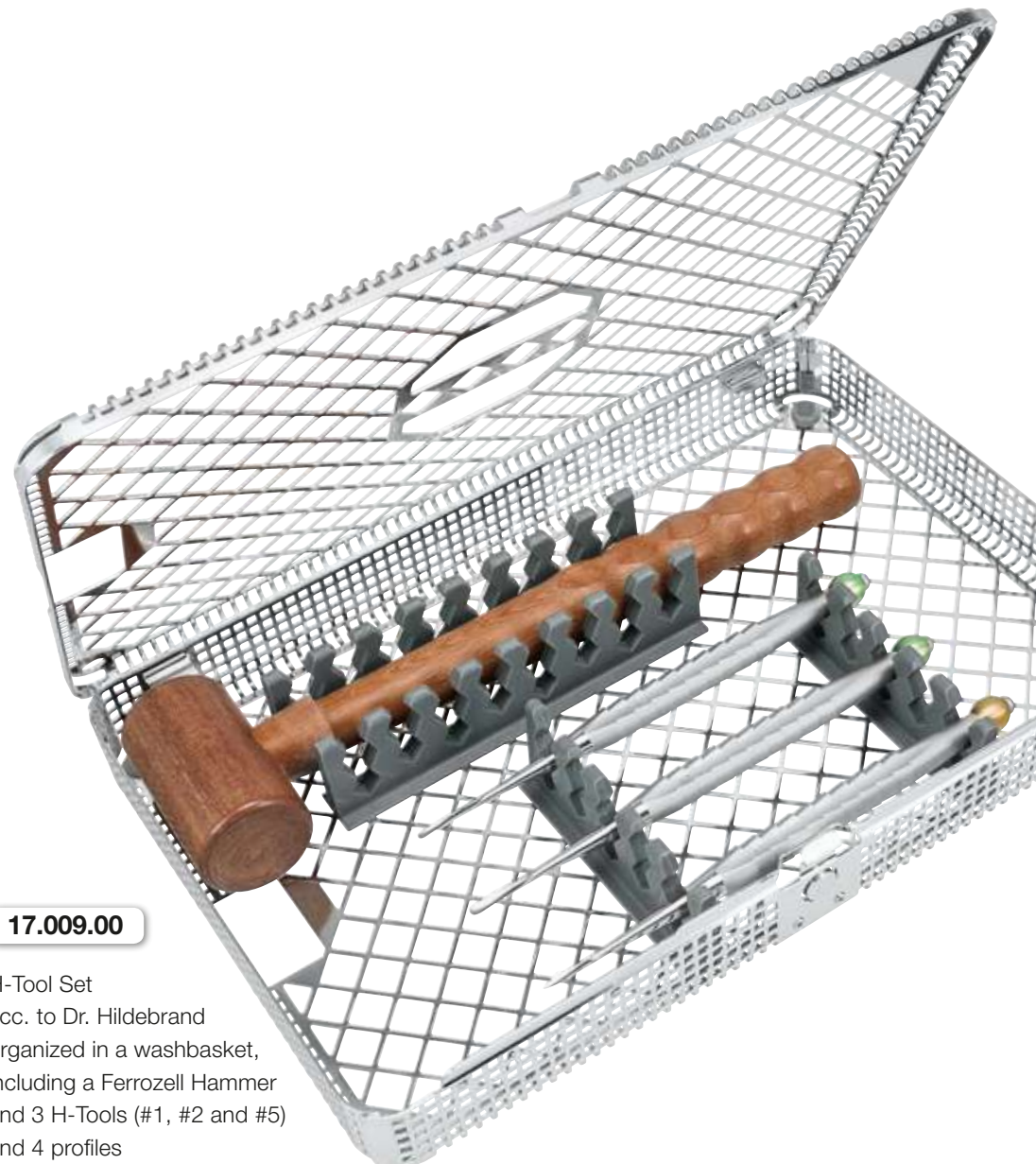

**17.009.00**

H-Tool Set  
acc. to Dr. Hildebrand  
organized in a washbasket,  
including a Ferrozell Hammer  
and 3 H-Tools (#1, #2 and #5)  
and 4 profiles



**85.195.00**

Washbasket 1/1  
as rack for the remaining components



**85.181.04**

Profile, high, universal,  
130 mm / for 8 instruments, 2 pieces



**85.181.05**

Profile, high, universal,  
81 mm / for 5 instruments, 2 pieces



**17.009.01**

H-Tool #1, straight, tip 2.5 mm, green ball



**17.009.02**

H-Tool #2, straight, tip 3.5 mm, green ball



**17.009.05**

H-Tool #5, straight, tip 3.0 mm, gold colored ball

## Witzel All-Purpose Root-Splinter Forceps

Our special forceps for extracting root splinters from both upper and lower gums have diamond-tipped jaws for the best possible grip and are the ideal complement to our Rescue-Line.

If their diamond tips should ever become worn, simply contact our retipping service, who will put new diamond tips on them for a fixed charge.

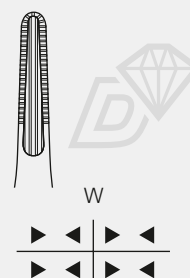

**14.700.01Z**

Witzel,  
diamond-tipped,  
Xcision Design,  
15 cm





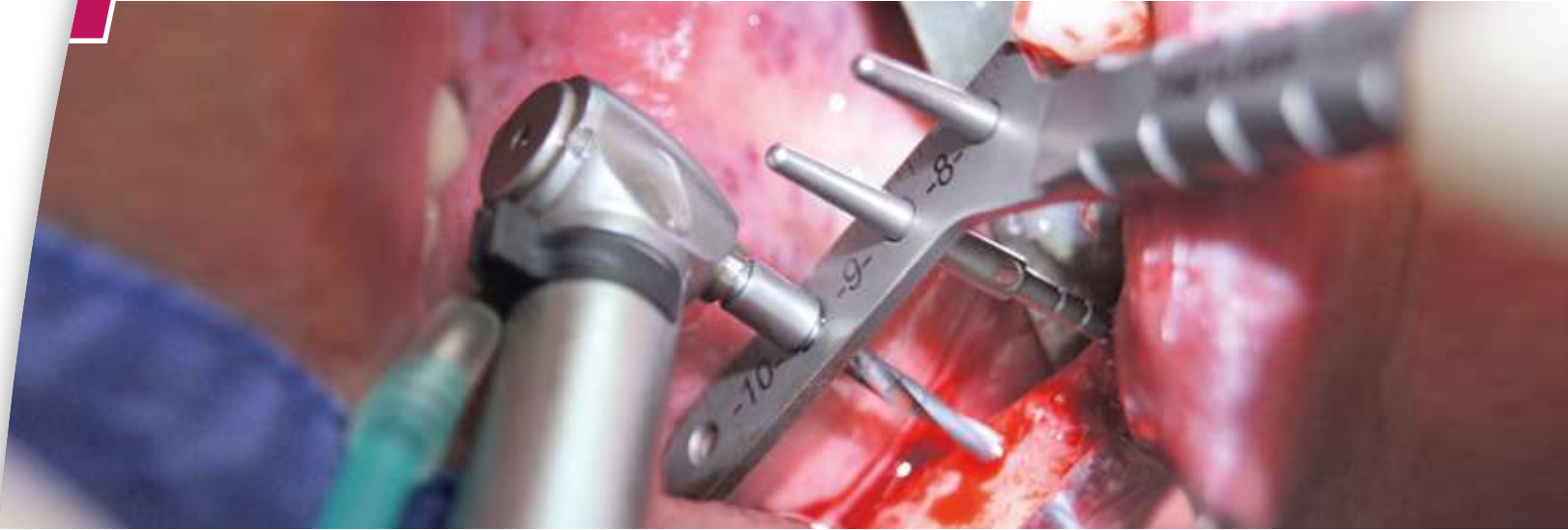

## Drilling Template

for the posterior tooth region, according to Wiedemann

A method was required to quickly and effectively find the right position for the implants during implantations in the posterior tooth region.

Here, a standard tooth width is assumed.

Premolars 8 mm, molars 10 mm, so 1/2 premolar = 4 mm,  
1/2 molar = 5 mm

The standard tooth widths used are neither scientifically nor individually 100% correct, but these values deliver highly usable implant positions particularly on edentulous jaws.



**31.683.00**

Drilling Template  
acc. to Wiedemann

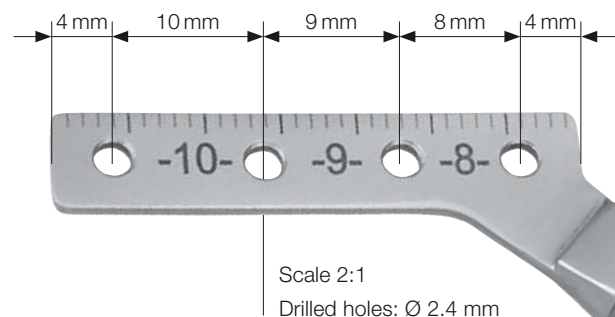

Scale 2:1

Drilled holes: Ø 2.4 mm

## Application Drilling Template



**A** First, the template is positioned. This can be done e.g. by using a PA probe through the first hole to feel for the center of the number 4 tooth, as shown here in the example. If the row of teeth ends with tooth 3, the mesial-facing end of the working part is placed distally against the widest point of tooth 3 (tooth equator).

The distance between the first hole and the edge of the working part is 4 mm.

As a result, the implant position and therefore the tooth center of tooth 4 is exactly 4 mm distal to the tooth equator of tooth 3.

The positions of teeth 5, 6 and 7 are located accordingly.



**B** Once the template is positioned with the first hole above the center of tooth 4, the position of tooth 5 can be marked with the second drilling at an exact distance of 8 mm.



**C** Once a pilot hole has been drilled to working length at the position of tooth 5, a paralleling pin can be inserted.

The template can be mounted on this, resulting in good stability that allows the position of tooth 6 to be found very easily and marked accordingly.

Proceed in the same way for tooth 7 as well.

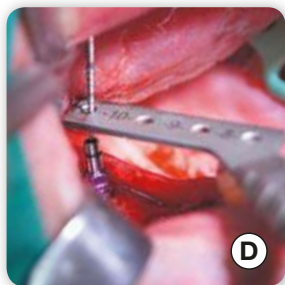

**D** Once the implantation is completely finished, the positions of the implants can be checked again with a PA probe.

If you hold the template with the first hole above the center of tooth 4, the 4th hole should be exactly in line with the position of tooth 7.



## Distance between drilled holes

- **8 mm:** From the center of one premolar to the center of the next premolar (1 x 4 mm + 1 x 4 mm), e.g. center of number 4 to center of number 5.
- **9 mm:** From the center of one premolar to the center of a molar (1 x 4 mm + 1 x 5 mm), e.g. center of number 5 to center of number 6.
- **10 mm:** From the center of one molar to the center of the next molar (1 x 5 mm + 1 x 5 mm), e.g. center of number 6 to center of number 7.

If no premolar is available as a starting point then a canine can also be used.

For this, a distance between the mesial end of the working part and the first hole of exactly 4 mm was chosen (1/2 premolar width).

## ZEPF Tunneling Instruments!

### Tunneling Instruments with a new angle

By request of several users, the modified **BIONIK** Tunneling Instruments from **HELMUT ZEPF** have now been supplemented with two new instruments. The instruments curved beyond the working tip allow even better access, especially in the posterior tooth region. Available in two sizes, depending on the extent of tunneling, the user can now select the ideal instrument for his / her purposes.



### Tunneling Instrument with holes

In **ZEPF BIONIK** handle. For upper and lower jaw with **ZEPF BIONIK** handle. Both ends with hole  $\varnothing$  0.8 mm for inserting the surgical suture, for easy insertion of the graft into the tunnel.



Tunneling Instrument # 3, 1.8 mm, 45° angled

46.040.03



Tunneling Instrument # 4, 2.5 mm, 45° angled

46.040.04



reddot design award  
winner 2010



Tunneling Instrument with holes, double-ended, in **ZEPF BIONIK** handle, grey, for upper and lower jaw, width 2.5 mm, each hole  $\varnothing$  0.8 mm

46.040.20



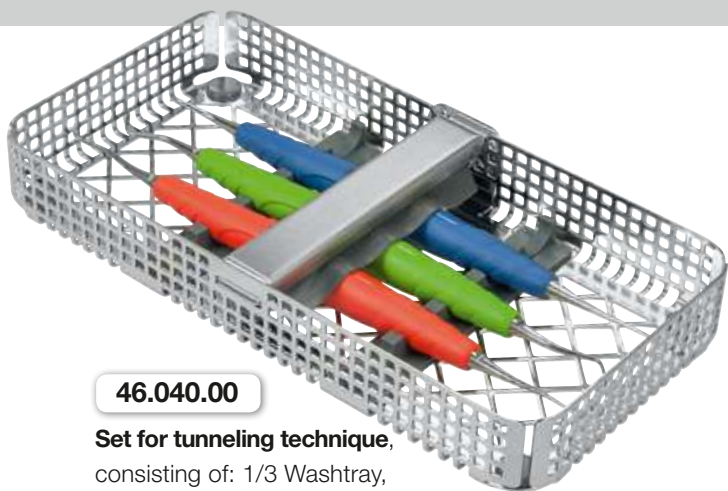

46.040.00

**Set for tunneling technique,**  
consisting of: 1/3 Washtray,  
Tunneling Instruments # 1 upper jaw,  
# 2 lower jaw, # 3 upper /lower jaw combination

## ZEPF Tunneling Instruments

In microsurgery, **HELMUT ZEPF BIONIK™** Tunneling Instruments find their application in the preparation of flaps or subsequent reconstructions of the alveolar ridge or for root coverings with a connective tissue graft. The instruments allow a minimally invasive tunneling preparation to avoid large openings. Due to the fine shaped raspatories tunneling incisions in the tissue are possible.



Tunneling Instrument # 1, for upper jaw, 18 cm

46.040.01



Tunneling Instrument # 2, for lower jaw, 18 cm

46.040.02



Tunneling Instrument combination # 3, upper /lower jaw, straight 1.8 mm,  
angled 1.7 mm, 18 cm

46.035.20



Periodontal Knife for the first access in tunneling technique in the front tooth region

46.040.07



Periodontal Knife for tunneling technique in the lateral tooth region. The slightly curved,  
pointed working tips are ideal to dissect in the lateral tooth region

46.040.08



Periodontal Knife with double angle to work in lateral tooth regions where  
access is difficult.

46.040.09



## Palatal Knife

acc. to Dr. med. dent. Iman Mizani, MS

The novel Palatal Knife offers an innovative alternative to the conventional scalpel for the preparation of connective tissue graft.

The special design of the instrument promotes faster and safer graft removal. At the same time, the risk of injury to the palatine artery and perforation of the palatal flap is minimized.

### Special features:

- angled cutting edge, perpendicular to the palatal bone
- ergonomic, angled instrument neck / shaft
- depth gauge (graduation) for precise dimensioning

### Advantages over conventional removal methods:

- enhanced safety through reduced risk of injury to the palatine artery and perforation of the palatal mucosa
- simple and ergonomic handling
- fast, precise preparation of the graft
- consistently uniform thickness of the connective tissue graft
- abrading work and cutting in difficult-to-reach places



**46.040.15**

Palatal Knife  
acc. to Dr. med. dent. Iman Mizani, MS

### Application:



① Singular palatal incision and formation of a flap



② Preparation to gain connective tissue, using the instrument



③ Dissection of the prepared connective tissue below the flap, removal of connective tissue as soon as the base is detached from the palatal bone

### Lucas Currettes – non-serrated and serrated

**ZEPF**-Line, double-ended, 17.5 cm



### ZEPF Application

Useful duo.

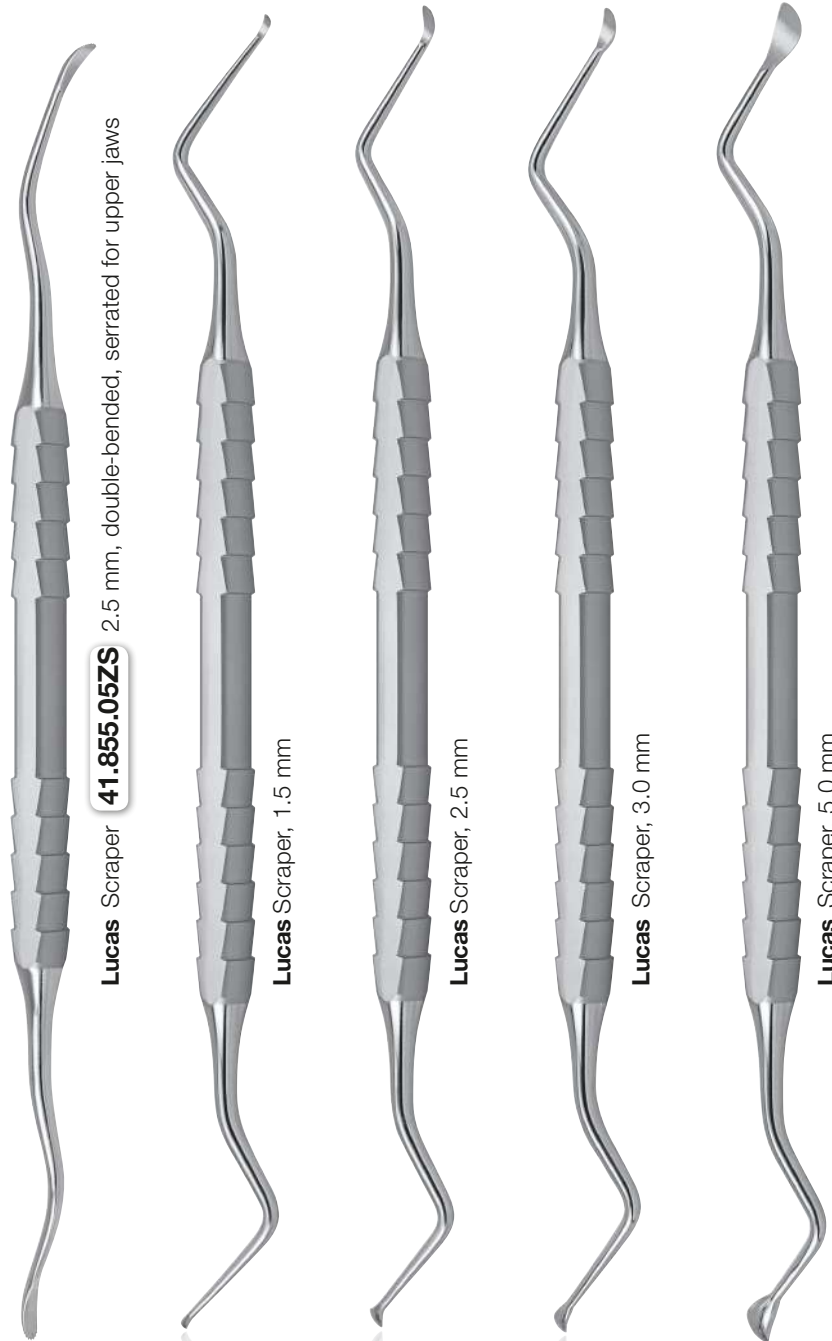

**Lucas Scraper 41.855.05ZS** 2.5 mm, double-bended, serrated for upper jaws

**Lucas Scraper**, 1.5 mm

**Lucas Scraper**, 2.5 mm

**Lucas Scraper**, 3.0 mm

**Lucas Scraper**, 5.0 mm



**Augmentation Material Applicator**, scoop, single-ended

**Filling instrument for augmentation material applicator** 19.714.21

- 'Z' non-serrated **41.855.00Z** **41.855.01Z** **41.855.02Z** **41.855.04Z**
- 'ZS' serrated **41.855.00ZS** **41.855.01ZS** **41.855.02ZS** **41.855.04ZS**

- 19.714.21** **19.714.22**
- 19.714.20**





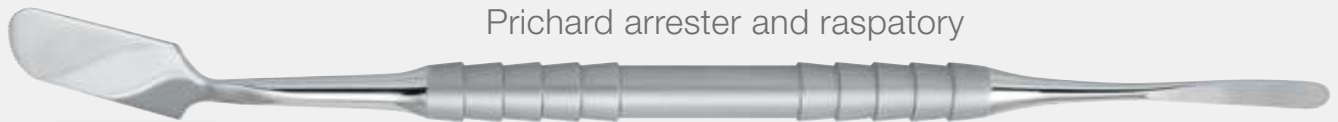

**41.878.11ZS**

Prichard Raspatory, serrated,  
PPR3, Retractor straight, 17.5 cm

Without serration:

**41.878.11**

Usable in all types of periodontic surgery, osteo-  
tomy, or root-tip resections.

Also with micro serration to prevent slipping from  
the bone.



Serration

**ZEPF MOLT**

**ZEPF Raspatories**

**Combination Instruments**

Spiculum Raspatory and round Periosteal Elevator



**41.862.20** MOLT Periosteal Elevator, CM4 / CM7, **ZEPF-Line**



2.6 mm

**41.864.13** Raspatory, **ZEPF-Line**



8 mm

**41.862.14** Raspatory combination, **ZEPF-Line**, with drill hole  
to place pins in the membrane, 17.5 cm

11 mm



2.4 mm

**41.864.30** 17.5 cm

2.8 mm



3.8 mm

**41.864.40** 17.5 cm

4.2 mm



3.8 mm

**41.864.50** curved, 17.5 cm

4.2 mm

### WEN Tension Release Comb

acc. to Dr. Wen, DBGM

Periodontal interventions for recession coverage are made to cover the root surface as complete as possible. If a soft tissue flap shall be translocated coronally, the WEN Tension Release Comb can be used to extend the split flap by combing, to easily achieve a complete coverage.

Depending on the condition of the soft tissue, flap extensions of 15 mm to 20 mm will be possible.

#### Application:

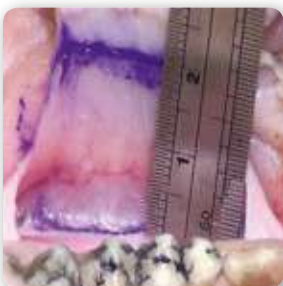

WEN Tension Release Comb acc. to Dr. Wen, DBGM, width of working tips 5 and 8 mm

41.865.01

### Periosteal Elevator Combination with Drill Holes

acc. to Dr. Niederquell, DBGM

To dissect the microperiosteum and to press the bone substitute into place, with simultaneous suction of excess fluids.



41.862.24



## Periosteal Elevator

Micro Raspatory acc. to Dr. Maty

- due to its slim design, the periosteal elevator can be used in all surgical interventions, particularly in **biological** dentistry, surgery and implantology
- safe exposure and retraction of the periosteum and good visual control
- lies perfectly in the hand and guarantees a safe support and guidance
- slip-resistant
- ergonomic shape for a better removal of the periosteum
- 3 working surfaces – front, right, left – allowing a fast flap opening of soft tissues / periosteum
- optimally suited for areas that are difficult to access, e.g. wisdom teeth in the upper and lower jaw, implants (distal)
- can be used as three-dimensional “curette” and periosteal elevator, e.g.
  - a) cleaning of the alveolus after tooth extraction
  - b) use in the apical region during apicoectomy
  - c) use in periodontal pockets (removal of soft tissues)
- the instrument is lightweight, has a good grip, is easy to handle and is slip-resistant
- the periosteal elevator can be fixed and placed easily with the index finger (even in areas that are difficult to access)
- claw and clover-shaped tips to serve as pusher to release the mucoperiosteal flap



scale 2:1



**41.864.80**

Periosteal Elevator acc. to Dr. Maty,  
**ZEPF-Line**, Micro Raspatory, double-ended



**41.854.80**

Periosteal Elevator acc. to Dr. Maty, in **ZEPF BIONIK** Handle,  
yellow green, Micro Raspatory, double-ended



## Nizam Ring Punch

'Tissue is the issue'



Soft tissue augmentation with ring-shaped keratinized tissue grafts (KTG), harvested with the NIZAM Ring Punch.



**08.921.00**

Nizam Ring Punch  
Surgical body length 5 mm,  
inner-Ø 4 mm, outer-Ø 7 mm, single use

Keratinized tissue grafts (KTGs) are widely used in modern implantology for peri-implant soft tissue management and in various periodontal plastic surgical interventions such as root coverage, papilla reconstructions and alveolar ridge preservation. KTGs are accepted as the gold standard for root coverage procedures and peri-implant soft tissue augmentation techniques, since they have high success rates and satisfactory esthetic outcomes.

However, KTG harvesting methods are technique sensitive procedures that need a certain level of surgical skill and experience, and may cause complications such as postoperative hemorrhage, pain, swelling, flap necrosis and sensitivity in the donor area.

The ring method is a simplified novel KTG harvesting technique which can be used in the maxillary tuberosity area in particular. A special KTG harvesting punch is fabricated to obtain a ring-shaped KTG that has a uniform thickness. The ring graft can then be used for peri-implant and periodontal soft tissue augmentation purposes with successful clinical outcomes.

The punch is composed of two sharp punches and a shank, which fits to a contra-angle.

The punch is placed perpendicular to the soft tissue surface and at least 1 mm away from the neighboring teeth. The contra-angle is used at 50 rpm without irrigation, and the punch penetrates the soft tissue until it reaches the bone surface and is then removed gently. The KTG punch creates two circular incision lines parallel to one another. A fine elevator is used to remove the ring graft by blunt dissection, leaving a soft tissue island in the donor area. The graft is soaked in saline to prevent dehydration until stabilized to the recipient area. The donor area is not sutured but left for blood clot formation between the soft tissue surfaces.

The ring technique is a technically intensive method that can be used to harvest KTG, mainly from the maxillary tuberosity. The ring graft can be effectively used for peri-implant soft tissue augmentation purposes.



## ZEPF Bone Holding Forceps

acc. to Dr. Howard Gluckman

### In use:



**23.105.50**

**ZEPF** Bone Holding Forceps  
acc. to Dr. Howard Gluckman

## Krekeler Sliding Caliper

acc. to Prof. Dr. med. dent.

Gisbert **Krekeler**

Modif. Dr. med. dent. Sven Marcus

Beschnidt

The Sliding Calipers combine a variety of functions in one instrument, thus facilitating the positioning of implants and enlarging the precision.

The new locating screw, at the end of the caliper, allows a fixation of the measured result. This practice-oriented development represents a significant relief with regard to a **more precise, quick and secure work.**

**31.693.10**

Sliding Caliper  
for measuring  
of implants with  
locating screw

**ZEPF**  
Classics



## Universal Handle Endo-Control

acc. to Dr. Carsten Franke

Due to its laser-marked measuring scale, the **HELMUT ZEPF** Endo-Control Mouth Mirror Handle allows a simple determination of the required working length. The measuring precision can be adjusted to 0.5 mm. The sandblasted surface reduces reflections on the Endo-Control instrument surface.



**24.454.03**

### CPG 11.5 (WHO)

Periodontal Probe exchangeable, M2.5, graduation 3.5/5.5 /8.5/11.5 mm



Application  
**ZEPF** Endo-Control

**26.180.07**

Universal Handle  
**ZEPF**-Line, single-ended,  
M2.5, with endo calibration

## ZEPF Bone Scraper II



By using the Bone Scraper, instruments like bone filters, trephines, saws and bone mills are no longer necessary. Its blades allow a fast harvesting of cortical and cancellous bone. The cost-efficient disposable blade offers the practitioner an always sharp and economical instrument.



← **Spare Blade**  
disposable

**47.957.30**

PU 3 pieces

**47.957.50**

PU 5 pieces



← **Sleeve**

**47.957.70**

**Bone Scraper II**  
**ZEPF**-Design, with sleeve  
and disposable blade

**47.957.10**

← straight version

**47.957.15**

angled version →



**Bone Scraper II Handle**

**47.957.60**

← straight version

**47.957.65**

angled version →



### Essential advantages:

- ergonomically perfect
- easy cleaning
- quickly replaceable disposable blade
- simple application
- cost-efficient





## Retractor „Whale Fin“ acc. to Dr. Maty

Both sizes of the „Whale Fin“ Retractor are available as insert M4 x 0.5 or as complete instrument in a **ZEPF BIONIK** handle.

### Advantages:

- good view of the operating and preparation field
- safe retraction of soft tissues and good visual control even in the lateral tooth area
- atraumatic – no punctual contact, but surface contact
- extra opening for the labial frenulum (upper jaw / lower jaw) with center cut-out in the middle of the retraction area / working surfaces
- wave-shaped working surface for a better adaptation in the upper jaw / lower jaw
- also usable in prosthetics (e.g. tooth preparation)

The ergonomic shape of the periosteal elevator and the retractor allow an easy cleaning and sterilization procedure.



37.448.35

37.446.07

37.448.30

37.446.06



## Laster Special Retractor

Special retractor for upper impacted wisdom teeth



37.438.15

**ZEPF** Laster special retractor for upper impacted wisdom teeth, sandblasted handle, polished working tip and micro serration, 100 mm

## Kim Retractor

The Kim Retractor is very useful to retract the soft tissue flap in a wisdom tooth extraction.



The working end is rounded, angled by 45° and serrated in the support region, thus allowing an optimal access to this area under excellent support on the bone.

37.446.04

Retractor acc. to Kim, flat, 45° angled, 10.5 mm wide

## Maty Cheek and Lip Retractor

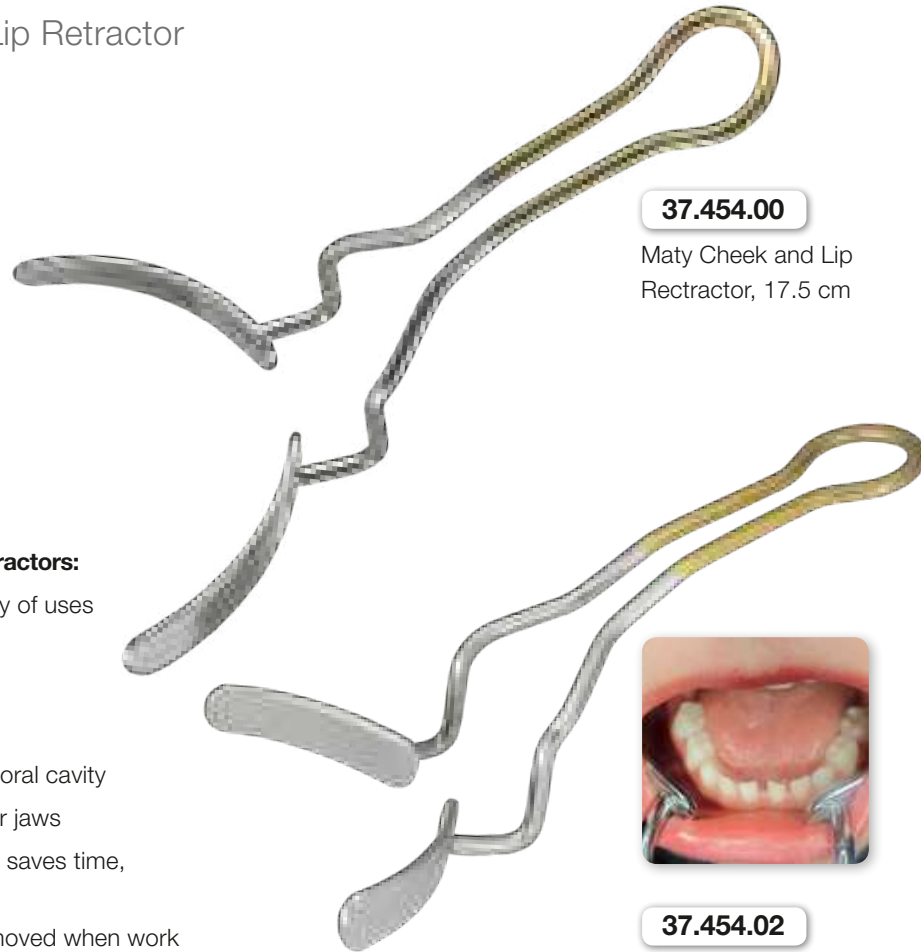

**37.454.00**

Maty Cheek and Lip  
Retractor, 17.5 cm

### Special Features of the Maty Cheek and Lip Retractors:

- suitable for a wide variety of uses
- lightweight
- easy to use
- patient-friendly
- no traumatization of the oral cavity
- usable on upper or lower jaws
- ergonomically designed, saves time, thereby cutting costs
- does not need to be removed when work is interrupted since design prevents the dropping out



**37.454.02**

Maty Cheek and Lip  
Retractor for children



## Special Retractor

mod. acc. to Dr. Müller



**Cawood-Minnesota**

**37.437.17**

16.5 cm, mod. acc. to Dr. Müller

## Special Retractor

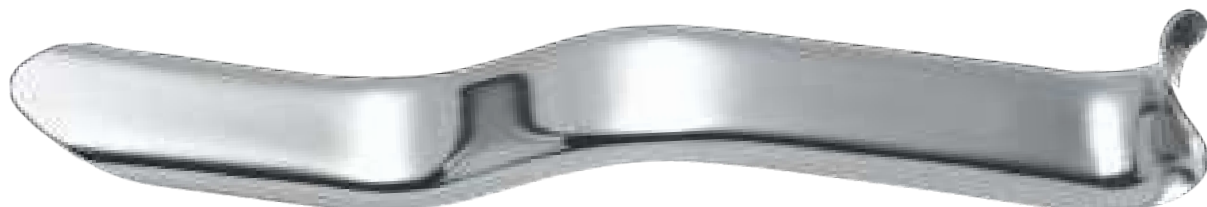

**Cawood-Minnesota**

**37.437.15**

15.5 cm



## ZEPF Mathieu Needle Holders

with tungsten carbide inserts

The two new needle holders are characterized by highest ergonomics and functionality. TC carbide inserts ensure almost wear-free work.

The three-stage, external lock offers an excellent holding function and can be quickly released with minimal effort.



### What is TC ?

TC stands for "Tungsten Carbide", a material whose superior strength wear resistance and hardness are its major properties that distinguish it from conventional materials.



**41.311.17TC**

Mathieu Needle Holder,  
with tungsten carbide inserts  
and external lock, **curved**,  
17 cm



**41.319.17TC**

Mathieu Needle Holder,  
with tungsten carbide inserts  
and external lock, narrow,  
**straight**, 17 cm



## ZEPF Scissors

**Our Scissors are available in different styles.  
They can be identified by the letters following the article number.**

**What is  ?**

SC stands for "Supercut" and means that scissors with this designation have been specially ground, not only to make them sharper than ordinary scissors, but yield a better cutting angle with serrated edges. One ring is golden.

**What is  ?**

TC stands for "Tungsten Carbide", a material whose superior strength wear resistance and hardness are its major properties that distinguish it from conventional materials. Both rings are golden.

**What is  ?**

The Onyx coating offers a 3-5 times higher surface hardness compared to traditional scissors. In combination with the "Supercut" grinding, this guarantees an extremely long product life and application with very high precision and wear resistance. The extraordinary surface smoothness is leading to an easy slide of the scissor blades even under highest strain. Due to the physical / chemical combination of the coating, no undesirable reaction will be caused during sterilization or usage of solvents.

Furthermore, the anti-glare surface avoids disturbing light reflections.

The article numbers are complemented by **TISC**.

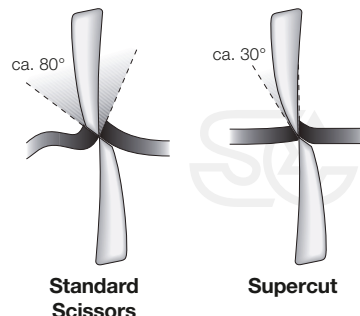

**Kelly Scissors, curved, 16 cm**

**Standard**





**onyx**

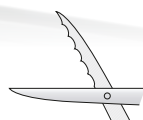

**46.077.16**

serrated edge



**46.077.16SC**

serrated edge



**46.077.16TC**

serrated edge





**46.077.16TISC**

serrated edge

### ZEPF Scissors

Dean, Howard Müller, 17 cm

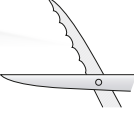
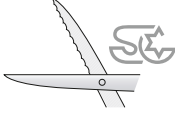



			
<b>46.123.17</b>	<b>46.123.17SC</b>	<b>46.123.17TC</b>	<b>46.123.17TISC</b>
serrated edge	serrated edge	serrated edge	serrated edge



Metzenbaum Preparation Scissors, # 1, blunt / blunt, curved, 14 cm

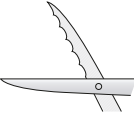

		
<b>46.431.14</b>	<b>46.431.14SC</b>	<b>46.431.14TISC</b>
serrated edge	serrated edge	serrated edge

## ZEPF Scissors

Iris Scissors, Gingivectomy Scissors, extra large rings, straight, 11.5 cm



Iris Scissors, Gingivectomy Scissors, extra large rings, curved, 11.5 cm







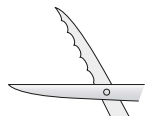

**ZEPF** Scissors

**Goldman-Fox** Gingivectomy Scissors, 13 cm



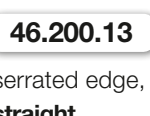
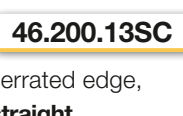
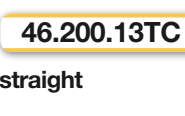
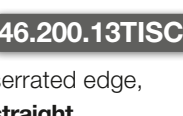

				
<b>onyx</b>	<b>46.201.13</b>	<b>46.201.13SC</b>	<b>46.201.13TC</b>	<b>46.201.13TISC</b>
	serrated edge, <b>curved</b>	serrated edge, <b>curved</b>	<b>curved</b>	serrated edge, <b>curved</b>
				
<b>onyx</b>	<b>46.200.13</b>	<b>46.200.13SC</b>	<b>46.200.13TC</b>	<b>46.200.13TISC</b>
	serrated edge, <b>straight</b>	serrated edge, <b>straight</b>	<b>straight</b>	serrated edge, <b>straight</b>



**Goldman-Fox** Gingivectomy Scissors, compound curved, 13 cm

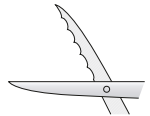

	
<b>46.207.13</b>	<b>46.207.13SC</b>
serrated edge	serrated edge

### ZEPF Scissors

La Grange Gingivectomy Scissors, double curved, 11.5 cm

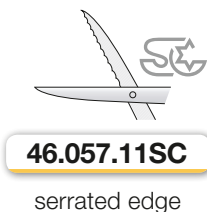
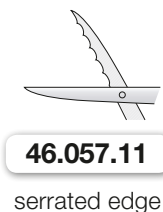
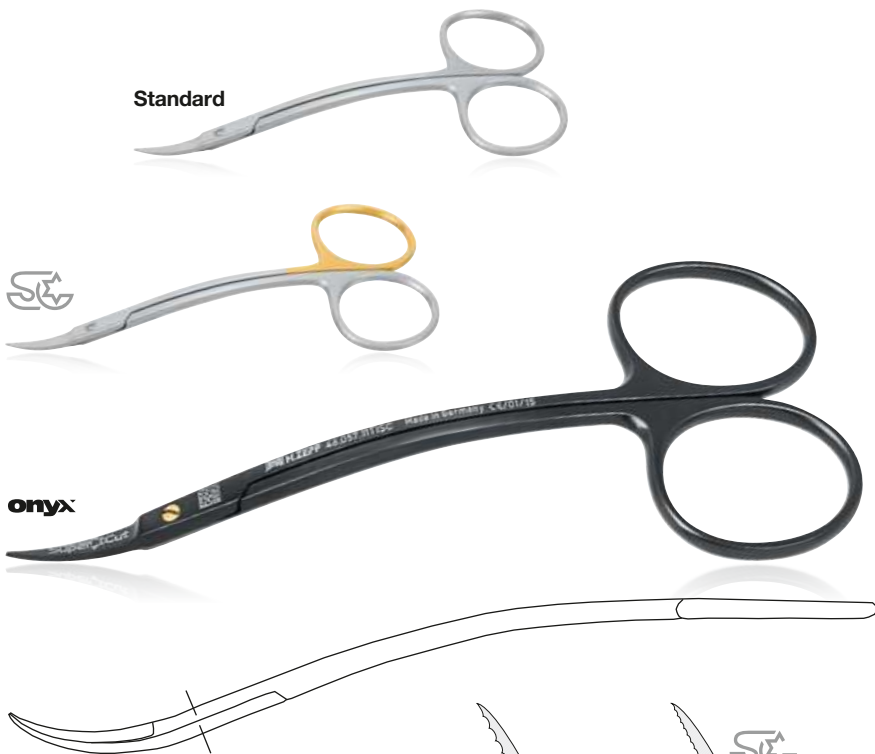

Joseph Gingivectomy Scissors, curved, 14 cm



## Augmentation Kit

Reasons for reconstruction of alveolar ridge occur due to defects in the jaw ridge areas. The most frequent causes are: Atrophy of the alveolar ridge and extraction defects.

At least for aesthetic reasons, in visible areas, these defects need to be reconstructed.

The augmentation is carried out with autologous bone and titanium foil. The bone implants are covered with a titanium foil after application. To avoid dislocation of the augmentation material below the membrane, the membrane is fixed with at least 2 pins.

The titanium pins with a length of 3 mm or 5 mm are taken out of the storage box by means of the applicators and pressed into the bone through the foil or membrane.

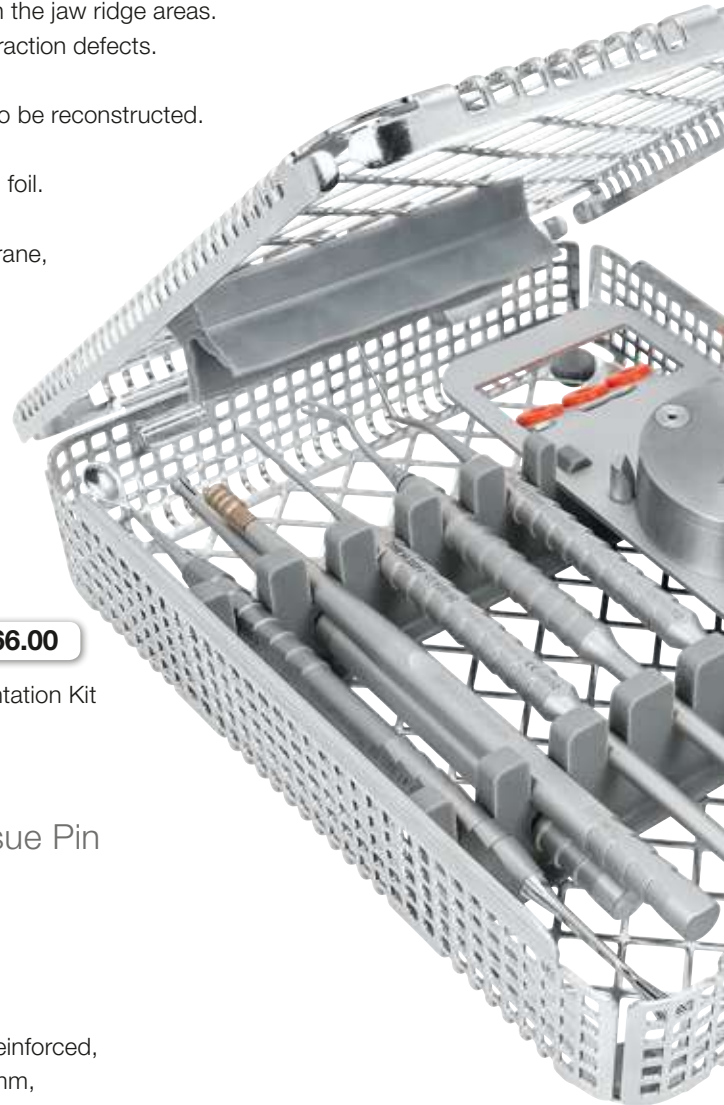

**47.966.00**

Augmentation Kit



**47.520.10**

**Option:**

Applicator for Soft Tissue Pins



**ZEPF** Soft Tissue Pin



**47.561.06\***

**Option:**

**ZEPF** Titanium Pin, reinforced,  
Ø 1 mm, shank 0.8 mm,  
plate Ø 3.5 mm, 6 mm long,  
specifically for soft tissue grafting



**85.255.02**

**Option:**

Storage Box for 10 titanium pins



**Illustration**

**Article Description**



**47.966.00**

Augmentation Kit, consisting of:  
Pin Membrane Probe, Pin Applicator,  
Perforation Raspatory, Sinus 7 Instrument,  
Titanium Pin 3 mm (10 pieces) / 5 mm  
(5 pieces), Pin Remover, Mixing Cup,  
Storage Box, 1/2 Washbasket with Lid  
85.194.15

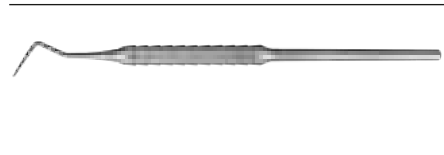

**47.520.00**

Pin Membrane Probe  
with **ZEPF**-Design handle



**47.520.01**

Pin Applicator



**47.520.02**

Perforation Raspatory

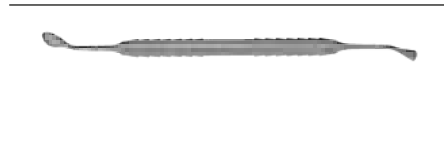

**47.520.03**

Sinus 7 Instrument acc. to Kirsch, Spoon  
Ø 6.0 mm / flexible Plugger Ø 5.0 mm



**47.560.03\***

Titanium Pin, 3 mm long,  
Ø 2.5 mm (10 pieces included in the set)



**47.560.05\***

Titanium Pin, 5 mm long,  
Ø 2.5 mm (5 pieces included in the set)

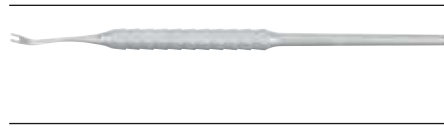

**47.847.12**

Pin Remover, to remove soft tissue pins



**85.251.04**

Mixing Cup, stainless steel,  
with plastic lid, Ø 4 cm

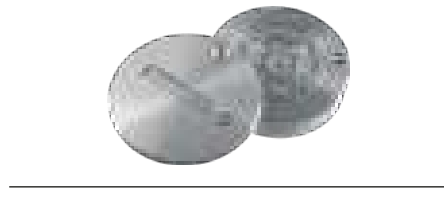

**85.256.00**

Storage Box, for 5 soft tissue pins  
and 10 titanium pins



**85.255.02**

**Option:** Storage Box for 10 titanium pins,  
if a compact solution is requested





## Bone Expander System

To expand resorbed bone with a controlled minimally invasive technique, helical spreaders can be used as an alternative to osteotomes.

The cancellous bone is expanded and condensed which leads to a higher primary stability for subsequent implant insertion.

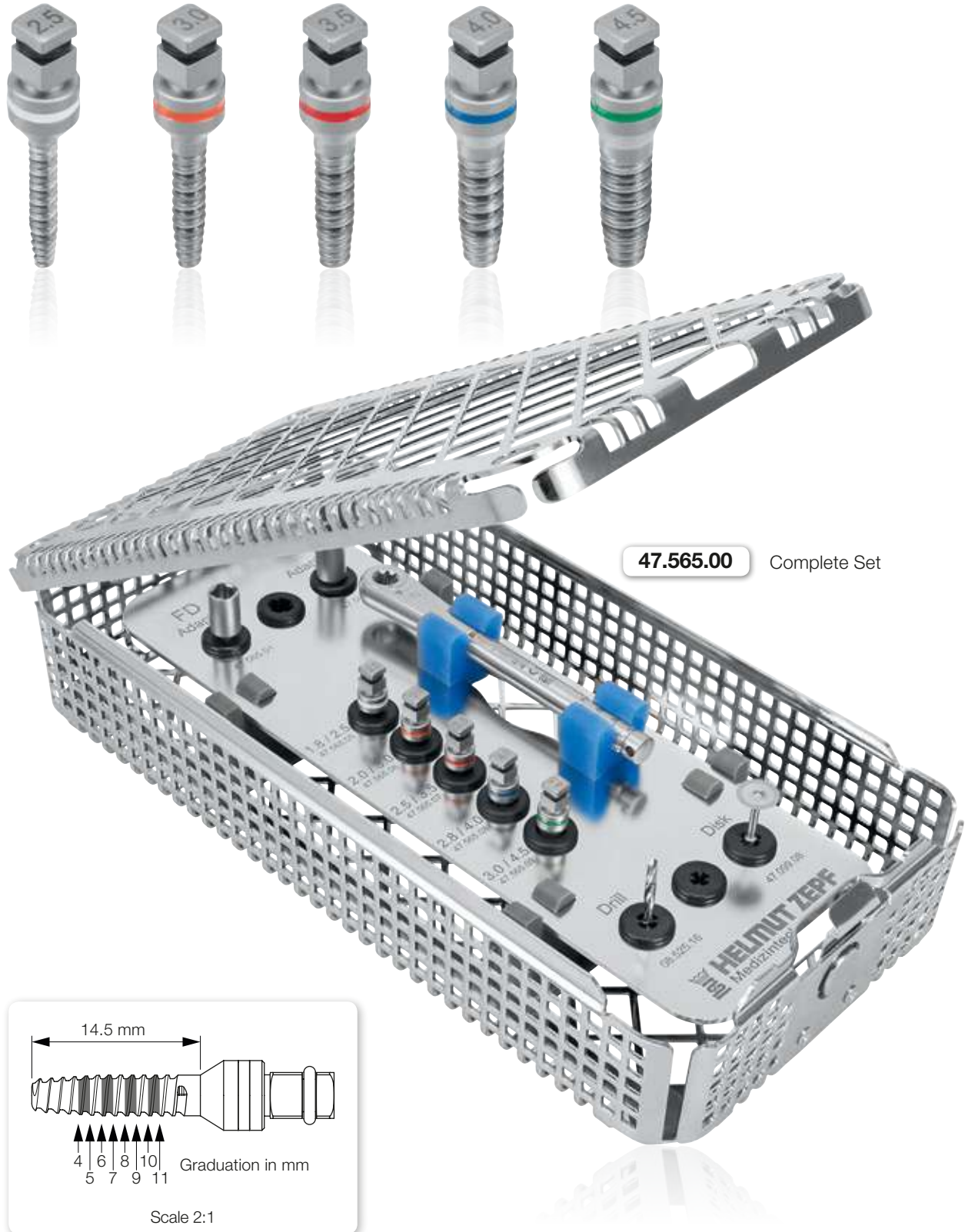

## Content of the Bone Expander System

## Illustration

## Article Description

## Order Quantity

**47.565.00**

Bone Expander System  
organized in a washbasket 1/3 with lid  
(REF 85.192.65)

1 set

## consisting of:

**47.565.05**

Expansion Screw 1.8 x 2.5 mm x 14.5 mm

1 piece

**47.565.06**

Expansion Screw 2.0 x 3.0 mm x 14.5 mm

1 piece

**47.565.07**

Expansion Screw 2.5 x 3.0 mm x 14.5 mm

1 piece

**47.565.08**

Expansion Screw 2.8 x 4.0 mm x 14.5 mm

1 piece

**47.565.09**

Expansion Screw 3.0 x 4.0 mm x 14.5 mm

1 piece

**47.800.05**

Wrench without torque

1 piece

**47.565.01**

Adapter with dental connector

1 piece

**47.565.02**

Adapter with square fitting

1 piece

**47.099.08**

Saw Separating Disc Ø 8 mm

1 piece

**08.525.16**

Drill Ø 1.96 x 15 mm

1 piece



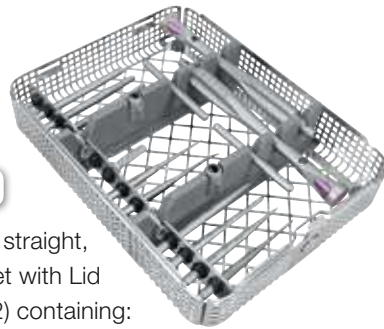

**47.990.00**

VGO Ost-Set – straight,  
in a Washbasket with Lid  
(REF 85.194.22) containing:

## ANTERIOR **VGO** OST-Set

with 7 straight screw osteotome inserts, numbered from 0-6

- Tips have first 8 mm threaded
- Produce micro cuts in bone
- Increased bleeding and better angiogenesis
- No malleting needed
- Tip-0 is unique in straight kit (Ø 1 - Ø 2 mm)
- Tip-0 to accommodate thin anterior ridges
- Provides precision marking tips for immediate placement

### Included in both sets:



**17.710.00**

Z-Shape Universal handle & instrument holder for inserts with  
HEX-adapter, AF4, sandblasted, 2 pieces included in the set



**47.990.06**

Precision Marking Tip, bent,  
scale 8/10/13/16 mm



**47.990.08**

Precision Marking Tip, straight,  
scale 8/10/13/16 mm



## Straight Screw Osteotomes in the **VGO** OST-Set

Exchangeable with Hex Connection for Z-Shape Universal handle

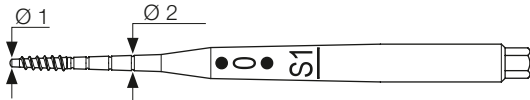

**47.990.10**

Screw Osteotome Insert straight, size 0,  
tapered Ø 1 - 2 mm, convex shank Ø 2 mm,  
scale 8/10/13/16 mm

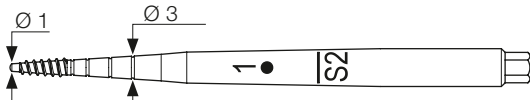

**47.990.20**

Screw Osteotome Insert straight, size 1,  
tapered Ø 1 - 3 mm, convex shank Ø 3 mm,  
scale 8/10/13/16 mm

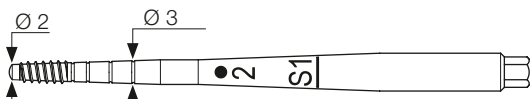

**47.990.30**

Screw Osteotome Insert straight, size 2,  
tapered Ø 2 - 3 mm, convex shank Ø 3 mm,  
scale 8/10/13/16 mm



**47.990.40**

Screw Osteotome Insert straight, size 3,  
tapered Ø 2 - 4 mm, convex shank Ø 4 mm,  
scale 8/10/13/16 mm

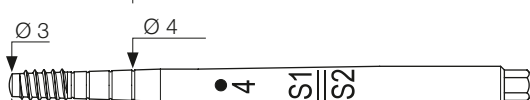

**47.990.50**

Screw Osteotome Insert straight, size 4,  
tapered Ø 3 - 4 mm, convex shank Ø 4 mm,  
scale 8/10/13/16 mm



**47.990.60**

Screw Osteotome Insert straight, size 5,  
tapered Ø 3 - 5 mm, convex shank Ø 5 mm,  
scale 8/10/13/16 mm



**47.990.70**

Screw Osteotome Insert straight, size 6,  
tapered Ø 4 - 5 mm, convex shank Ø 5 mm,  
scale 8/10/13/16 mm

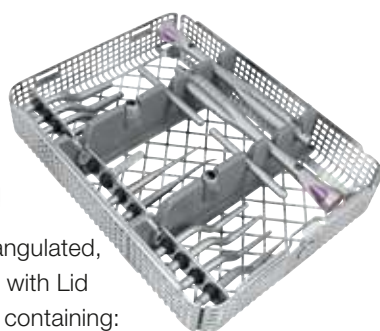

47.991.00

VGO Ost-Set – angulated,  
in a Washbasket with Lid  
(REF 85.194.22) containing:

## POSTERIOR **VGO** OST-Set

with 8 angulated osteotome inserts, numbered from 1 - 8

- No threads since turning motion limited
- 5 mm mark placed on all tips to mark threshold for crestal lift
- 5 mm is minimum available bone recommended for crestal lift
- Tips have same taper as tips 1-6 for straight kit
- Two additional tips (7 and 8) to accommodate wider ridges typically found in posterior area
- Provides precision marking tips for immediate placement

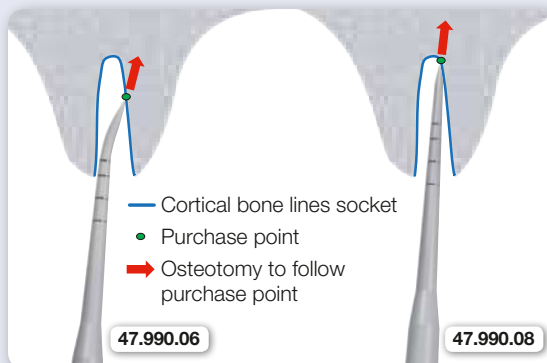

### Application of the Precision Marking Tips

To be used during immediate placement surgery to initiate osteotomy offset towards palatal. Rotary drills usually slide down bone due to angle at which the osteotomy is initiated.

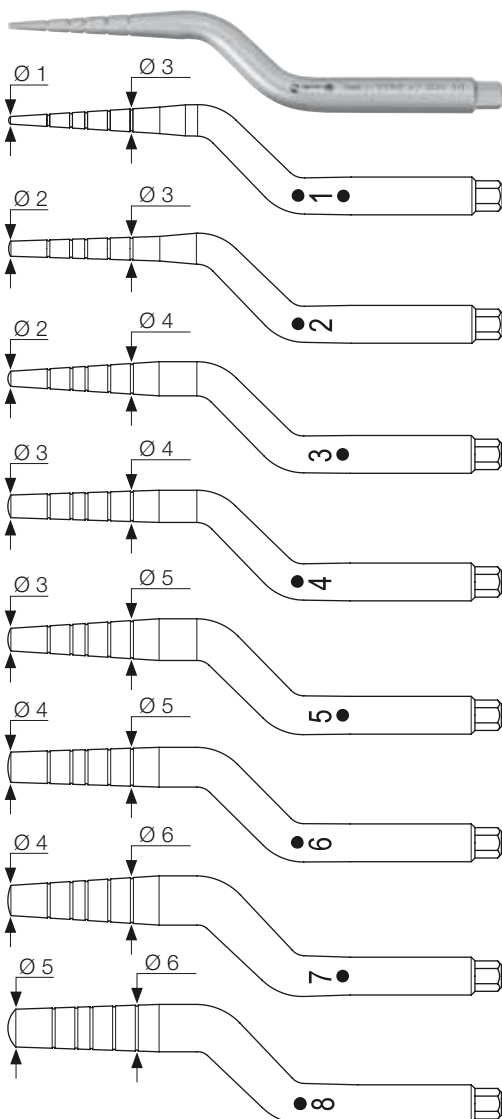

### Angulated Osteotomes in the **VGO** OST-Set

Exchangeable with Hex Connection for Z-Shape Universal handle

- 47.991.10** Osteotome Insert angulated, size 1, tapered Ø 1 - 3 mm, convex shank Ø 3 mm, scale 5/8/10/13/16 mm
- 47.991.20** Osteotome Insert angulated, size 2, tapered Ø 2 - 3 mm, convex shank Ø 3 mm, scale 5/8/10/13/16 mm
- 47.991.30** Osteotome Insert angulated, size 3, tapered Ø 2 - 4 mm, convex shank Ø 4 mm, scale 5/8/10/13/16 mm
- 47.991.40** Osteotome Insert angulated, size 4, tapered Ø 3 - 4 mm, convex shank Ø 4 mm, scale 5/8/10/13/16 mm
- 47.991.50** Osteotome Insert angulated, size 5, tapered Ø 3 - 5 mm, convex shank Ø 5 mm, scale 5/8/10/13/16 mm
- 47.991.60** Osteotome Insert angulated, size 6, tapered Ø 4 - 5 mm, convex shank Ø 5 mm, scale 5/8/10/13/16 mm
- 47.991.70** Osteotome Insert angulated, size 7, tapered Ø 4 - 6 mm, convex shank Ø 6 mm, scale 5/8/10/13/16 mm
- 47.991.80** Osteotome Insert angulated, size 8, tapered Ø 5 - 6 mm, convex shank Ø 6 mm, scale 5/8/10/13/16 mm





## VGO OST-Sets – AESTHETIC IS THE RESULT

### Advantages of the VGO Osteotomes

- ZERO HEAT PRODUCED!
- ALWAYS PASSIVE ENTRANCE!
- DECREASED CRESTAL STRESS!
- FULL CONTROL OF RATE OF DILATION!  
since hand-piece is not used at constant speed
- REVOLUTIONARY FLEXIBILITY OF USE  
All Osteotomes on the market may look alike, but they are not!  
We offer a unique stepped formula for tip escalation and a revolutionary flexibility of use like no other system on the market.

### 3 main modes of use!

ZEPF VGO MODE: **PASSIVE ENGAGEMENT** (Stepped Escalation)

ZEPF HYBRID MODE: **PASSIVE ENGAGEMENT** (Linear Escalation)

ZEPF STANDARD MODE: **PASSIVE ACTIVE ENGAGEMENT / NON ENGAGEMENT** (not recommended)

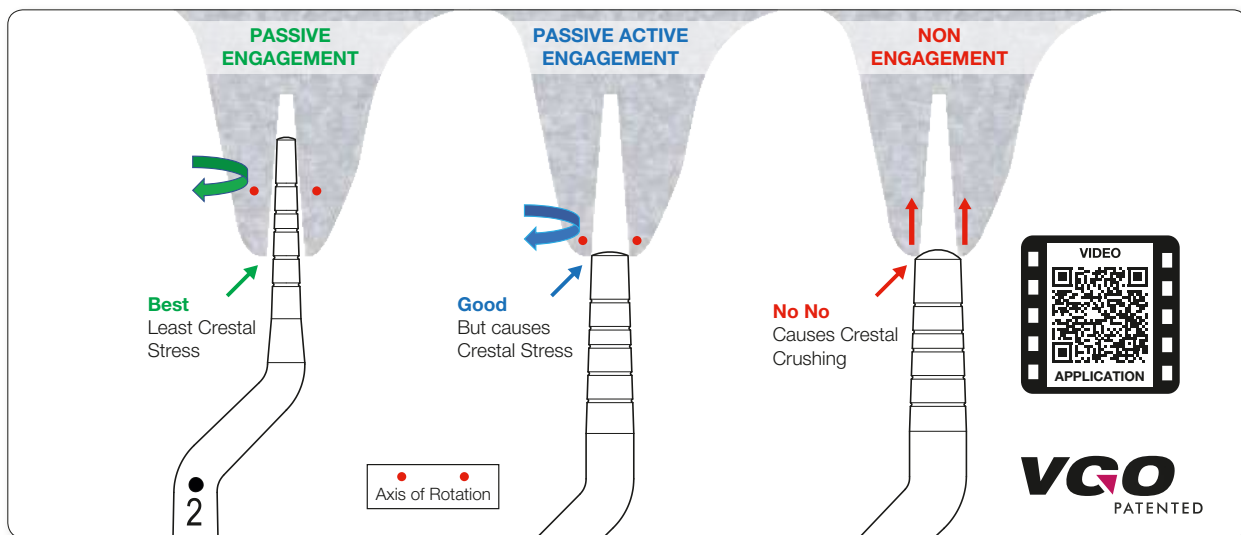

## Bone is Gold: PASSIVE WAVE DILATION SYSTEM

acc. to Pavel Krastev DDS

How do we manage the osteotomy ATRAUMATICALLY?  
How do we manage the osteotomy for greater implant success? Bone is Gold, so how do we hurt the bone less? How do we mallet less, as to make procedure less unpleasant for our patients?

Let us control the bone as opposed to having the bone control us.

**Because of the overlapping diameters of the VGO Osteotomes, you are able to passively engage the previously made intrabony cavity, even when You didn't use the full length of the tip.**

**PASSIVE ENGAGEMENT** – successive osteotome fits freely into the previous intrabony cavity and becomes active at a point deeper than crestal bone, as is currently done by the new ZEPF VGO Way.

**PASSIVE ACTIVE ENGAGEMENT** – when a traditional Summers Osteotome is used to full working depth of tool, the next Tip will engage previously made intrabony cavity passively and will start being active immediately as it progresses further into cavity.

**NON ENGAGEMENT** – when next osteotome is used, it simply does NOT fit the intrabony cavity created by previous osteotome. This is what occurs when traditional summers osteotomes are used to partial depth of tip.

## Bone-Splitting Set

acc. to Dr. Vollmer & Dr. Valentin

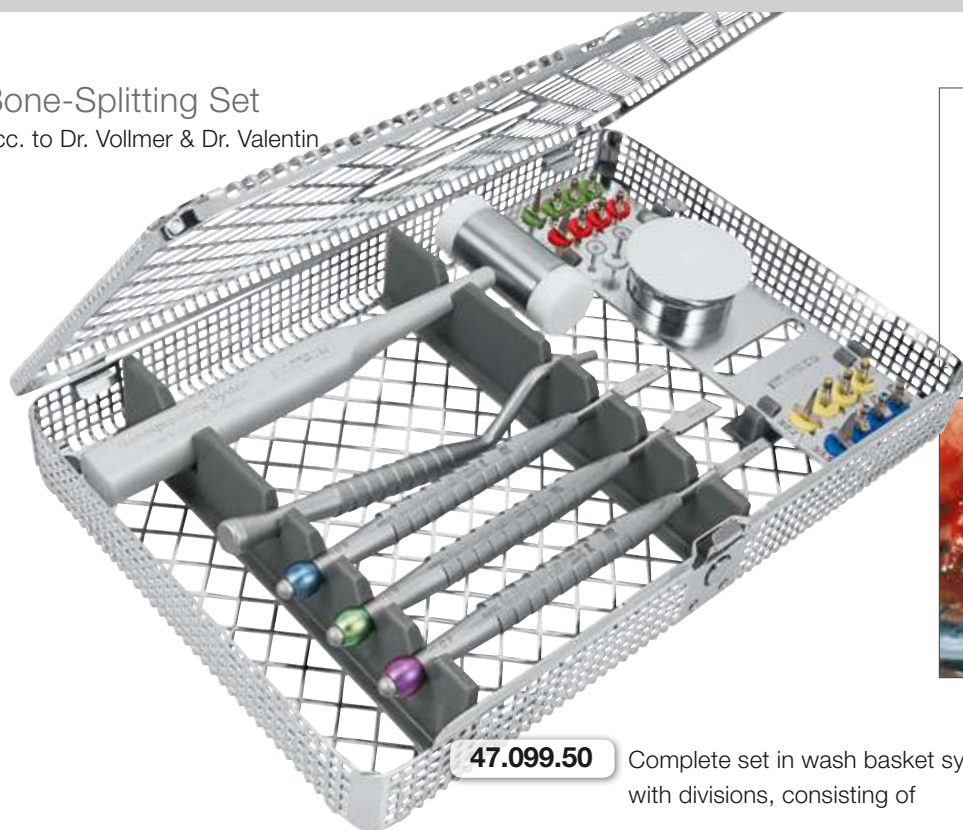

**47.099.50**

Complete set in wash basket system 85.195.65 with divisions, consisting of

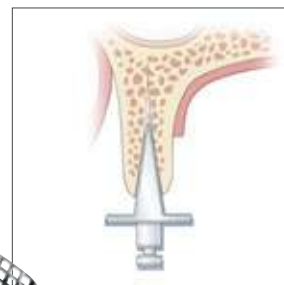

A successful implantation primarily depends on sufficient bone in the region of the alveolar process and especially on the quality of the bone. Only a stable bone structure can guarantee a safe anchorage of the implant. In addition to modern augmentation methods, the bone splitting technique is becoming more and more important.

The principle is based on the creation of a similar alveolar cavity in the maxillary crest with a good potential of regeneration. For this indication, the experienced implantologists Dr. Vollmer and Dr. Valentin have developed exactly adapted system components for different anatomical situations in co-operation with the company **HELMUT ZEPF**.

Art. No.	Description
<b>41.501.01</b>	Hammer with exchangeable plastic inserts, Ø 25 mm, light metal handle, acc. to Dr. Vollmer
<b>47.949.11</b>	Pointed Chisel 4 mm, red
<b>47.949.12</b>	Pointed Chisel 6 mm, blue
<b>47.949.13</b>	Pointed Chisel 8 mm, green
<b>47.099.08</b>	Separating Disc Ø 8 mm
<b>47.099.10</b>	Separating Disc Ø 10 mm
<b>47.099.31</b>	Wedge 2 mm / 2.2 mm, green
<b>47.099.32</b>	Wedge 2 mm / 3.5 mm, red
<b>47.099.33</b>	Wedge 3 mm / 2.2 mm, yellow
<b>47.099.34</b>	Wedge 3 mm / 3.5 mm, blue
<b>47.099.20</b>	Wedge Applicator
<b>85.251.04</b>	Medicine Cup, stainless steel, with plastic lid, Ø 40 mm x 30 mm high



### Inter-Implantary Wedges



**47.099.31**

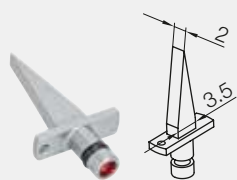

**47.099.32**

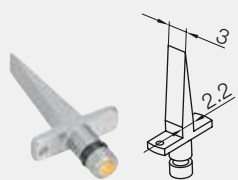

**47.099.33**

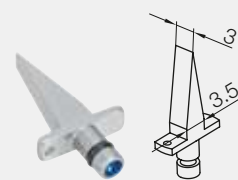

**47.099.34**



Benno Syfrig

## Benex® SinusLift Elevators

acc. to Dr. med., med. dent. Benno Syfrig

For internal sinus lift with osteotome technique (Summers technique), generally a height of at least 6 mm of remaining bone is required. If this height is lower, a sinus floor elevation by lateral window approach is recommended (external sinus lift).

In co-operation with the company **HELMUT ZEPF** Medizintechnik, Dr. med., med. dent. Benno Syfrig (CH) has developed an instrumentation allowing an easy, safe and practical elevation of the Schneider membrane through the implant tunnel to any height, independent of the offer of vertical bone.

The intervention is extremely gentle to the tissue. The buccal maxillary sinus wall and eventual sinus bone septums remain intact. This is to guarantee a good ossification of the augmentation material and an accelerated osseointegration of the implant.

**Intra-operative:** Release and elevation of the Schneider membrane with the sinus elevators # 1 and # 2

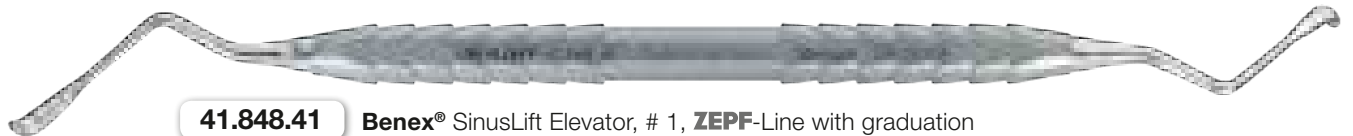

**41.848.41** Benex® SinusLift Elevator, # 1, ZEPF-Line with graduation

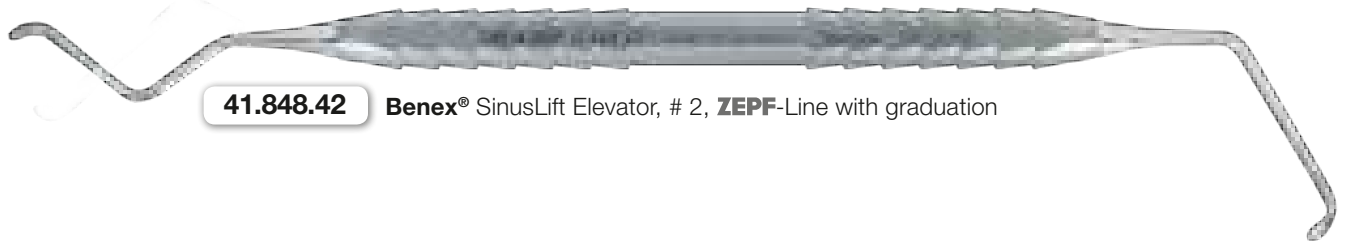

**41.848.42** Benex® SinusLift Elevator, # 2, ZEPF-Line with graduation

### Supplementary Instruments

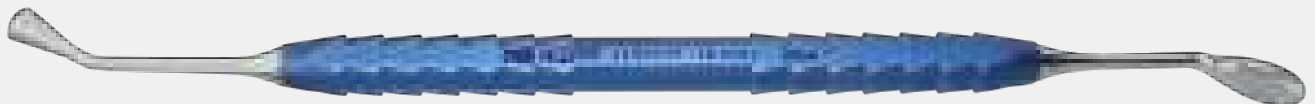

**41.868.07** Kirsch Sinus 7 Plugger, double-ended, 17.5 cm, Spoon 8 x 10 mm, Titanium ZEPF-Line

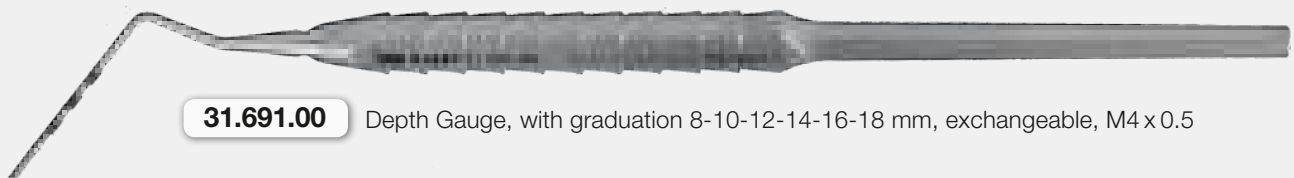

**31.691.00** Depth Gauge, with graduation 8-10-12-14-16-18 mm, exchangeable, M4 x 0.5

## Sinus Instrument Set acc. to Prof. Dr. Dr. Stiller



- Immediate sinus floor elevation with or without bone cover
- Particularly suited for difficult maxillary sinus structure (septa, maxillary pillars, scarred mutations in change with intact maxillary sinus mucosa)
- **Flexible working tips** (instruments are pre-bended for the normal enantral anatomy)
- Two different kinds of instruments with blunt and sharp edges for dissecting mucosa on plane and rough internal surface of the maxillary sinus
- Delicate working tips for the most complicated intraoperative situations, e.g. cicatrizations, situation after mouth-antrum connection, enantral preparation of the maxillary sinus mucosa on root surfaces and very thick facial maxillary sinus wall, preparation of remarkable recesses
- Glare-free working tips with polished edges allowing an ergonomic and atraumatic working
- Favorable resp. reduced natural oscillation behavior of the instruments in spite of flexible working tips
- Two mixing cups to collect autologous bone and to mix autologous blood with bone graft substitute
- Special maxillary sinus aspirators with perforations to avoid suction perforations; delicate working tips to allow precise working even in difficult situations

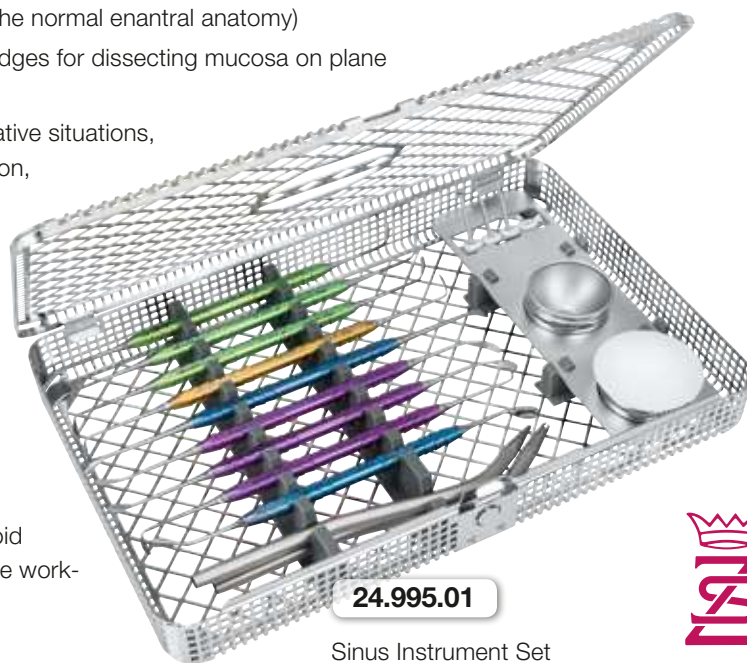

24.995.01

Sinus Instrument Set  
acc. to Prof. Dr. Dr. Stiller

Art.-No.	Description
08.902.031HF	HB Drill, 031HF, round
08.906.023C	Diamond, 023C, round, Ø 2.3 mm
08.906.029C	Diamond, 029C, round, Ø 2.9 mm
19.651.13	Surgical Aspirator, SinusLine, titanium tip, slotted, Ø 1.5 mm
19.651.14	Surgical Aspirator, SinusLine, titanium tip, slotted, Ø 3.0 mm
41.822.01	Stiller Sinus Elevator, blunt, 4.0 mm, bendable, double-ended, 19.5 cm, Titanium ZEPF-Line, green
41.822.02	Stiller Sinus Elevator, blunt, 2.5 mm, bendable, double-ended, 19.5 cm, Titanium ZEPF-Line, green
41.822.03	Stiller Sinus Elevator, blunt, 3.0 mm, bendable, double-ended, 19.5 cm, Titanium ZEPF-Line, green
41.822.04	Sinus Elevator, universal, 3.0 mm, double-ended, 19.5 cm, Titanium ZEPF-Line, yellow
41.822.05	Sinus Elevator, universal, 6.0 mm, double-ended, 19.5 cm, Titanium ZEPF-Line, blue
41.822.11	Stiller Sinus Elevator, sharp, 4.0 mm, double-ended, 19.5 mm, Titanium ZEPF-Line, red
41.822.22	Stiller Sinus-Elevator, sharp, 2.5 mm, double-ended, 19.5 mm, Titanium ZEPF-Line, red
41.822.33	Stiller Sinus-Elevator, sharp, 3.0 mm, double-ended, 19.5 mm, Titanium ZEPF-Line, red
41.868.07	Kirsch Sinus 7 Plugger, Spoon 8 x 10 mm, double-ended, 17.5 mm, Titanium ZEPF-Line, blue
85.251.04	Mixing Cup, stainless steel, with plastic lid, Ø 40 mm
85.251.14	Mixing Cup without plastic lid, stainless steel, Ø 40 mm
85.995.01	Washbasket 1/1 with Lid and Instrument Holders for Sinus Lift Instrument Set acc. to Prof. Dr. Dr. Stiller



## Kirsch Sinus Lift Instrument Set SMALL

for sinus floor elevation, modif. acc. to Dr. Kai Zwanzig

Responding to numerous customer requests, the proven Kirsch shapes were minimized during the further development of the new sinus lift instruments SMALL.

- The smaller instruments allow the preparation of a minimalized window.
- Regarding the angles of working tips, the previous Kirsch Instrument Set left nothing to be desired.

- The minimized analogous instruments now enable the practitioner to perform the preparation in a smaller area without injuring the Schneider's membrane.
- The **ZEPF**-Line-handle allows a safe, tactile guidance of the instruments.

Optionally, two instruments 41.868.05SL and 41.868.06SL with a longer 1st shaft are offered.



**41.868.01S** Kirsch, Sinus 1 SMALL, Elevator 25°, Titanium **ZEPF**-Line Handle, double-ended



**41.868.02S** Kirsch, Sinus 2 SMALL, Elevator 60°/60°, Titanium **ZEPF**-Line Handle, double-ended



**41.868.03S** Kirsch, Sinus 3 SMALL, Elevator 90°, Titanium **ZEPF**-Line Handle, double-ended



**41.868.04S** Kirsch, Sinus 4 SMALL, Elevator 120°/120°, Titanium **ZEPF**-Line Handle, double-ended



**41.868.05S** Kirsch, Sinus 5 SMALL, Elevator 90°/90°/60°, Titanium **ZEPF**-Line Handle, double-ended



**41.868.06S** Kirsch, Sinus 6 SMALL, Elevator 90°/90°, Titanium **ZEPF**-Line Handle, double-ended



**24.995.00S**

Complete Set incl.  
1 x washbasket with lid  
85.195.00 and arrangement  
for Sinus Lift Instrument Set



**85.251.04**

Mixing Cup, stainless steel,  
with plastic lid, Ø 40 mm

**85.251.14**

Mixing Cup without plastic lid,  
stainless steel, Ø 40 mm



**41.868.07S**

**Kirsch**, Sinus 7 SMALL, Plugger Ø 5.0 mm, Spoon 8 x 10 mm,  
Titanium **ZEPF-Line** Handle, double-ended



**41.868.08S**

**Kirsch**, Sinus 8 SMALL, convex Plugger Ø 4.5 mm, plane Plugger Ø 2.7 mm,  
Titanium **ZEPF-Line** Handle, double-ended



**41.747.03S**

Universal Raspatory, Sinus 0 SMALL, exchangeable inserts

Option:



**41.868.05SL**

**Kirsch**, Sinus 5 SMALL, long shank, Elevator 90°/90°/60°,  
Titanium **ZEPF-Line** Handle, double-ended



**41.868.06SL**

**Kirsch**, Sinus 6 SMALL, long shank, Elevator 90°/90°,  
Titanium **ZEPF-Line** Handle, double-ended



## Contrast PA Probe Inserts

The new **ZEPF** Contrast PA Probes are made of plastic material and dispose of a flexible working tip which adapts optimally to the anatomy of the pocket depth when measuring.

Colorstable, black markings on the white basic material guarantee a very good contrast for reading.

The sterilizable, exchangeable tips are available in different common graduations.

They are suited to determine the parodontal status and especially to be used on implants. Scratching of implant surfaces is avoided with these probes.

**The tips are reusable until they bend, the color fades or the graduation is not readable any more.**



**24.451.00** # 1

graduation 3/6 / 8/11 mm  
M4 x 0.5 mm, PU 12 pieces



**24.451.01** # CPG 12

graduation 3/6 / 9/12 mm  
M4 x 0.5 mm, PU 12 pieces



**24.451.02** # CPNG 22

graduation 2/4 / 6/8/10/12 mm  
M4 x 0.5 mm, PU 12 pieces



**24.451.03** # PCPG 11.5

graduation 3.5/5.5 / 8.5/11.5 mm  
M4 x 0.5 mm, PU 12 pieces



**24.451.06** # CNC

graduation 1 - 15 in mm steps,  
North Carolina  
M4 x 0.5 mm, PU 12 pieces



Assembly without a tool

**24.451.02** # CPNG 22

Periodontal Probe exchangeable, graduation:  
2/4 / 6/8/10/12 mm, M4 x 0.5 mm, PU 12 pieces

**26.193.15** **BIONIK** Universal Handle single-ended

**QUICKFIX**, lightred-magenta, incl. 1 end cap  
The handle is available in 10 different colors.



Flexible working tip

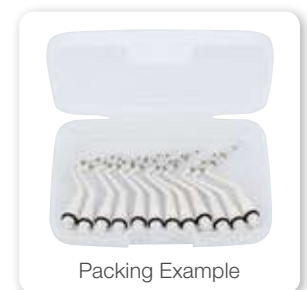

Packing Example

## ZEPF Photography and Cheek Retractor, in the Onyx Version or in stainless steel



**HELMUT ZEPF** Cheek Retractors are frequently used in intraoral photography, in extensive cheek retraction, in dental diagnostics and in surgical interventions.

Conventional retractors are also available in plastic material. However, depending on the used plastic, these are not always entirely harmless when being prepared in the hygiene chain. Our retractors are made of stainless medical steel and fulfill all the requirements of the RKI guidelines.



The ergonomic design of the retractors guarantees an optimal handling and is well accepted by patients.



**37.457.00TI**

1/1, scale 1:1

**37.457.00**

1/1, scale 1:2

**37.457.01TI**

**37.457.01**

1/2 left, scale 1:2

**37.457.02TI**

**37.457.02**

1/2 right, scale 1:2





## BIONIK<sup>ZEPF</sup> Retraction-Thread Plugger

Retraction threads are placed to repress or retract the gingiva from the tooth neck.

Prior to taking an impression for the preparation of crowns, the thread is adapted around the prepared tooth and the gingiva.

The **ZEPF BIONIK** Instruments feature specially adapted shapes, helping the dentist to place the threads in a time-saving way; this is useful as threads are tending to get thinner.



**24.548.01** Universal Thread Plugger with angled working tips, micro serrated



**24.548.02** Suture Applicator for distal / mesial use, micro serrated and specially adapted to anatomy



**24.548.03** Suture Applicator for buccal / lingual use, micro serrated and specially adapted to anatomy



**24.548.04** Universal Thread Plugger with round tips, micro serrated

## KRASTEV Abutment Holder

acc. to Pavel Krastev DDS, in **ZEPF BIONIK** Handle

When implant abutments are inserted into patient's mouth, abutments are most often held by fingers while trying to find and engage the hex of the implant. This is especially difficult when abutments are very short, or location is more difficult to access. When inserting abutments, one needs to orient a buccal mark to buccal. It is also necessary to engage the implant hex which is hidden under the soft tissue and is not easy to see! Because abutments are usually slightly tapered and very smooth they are almost impossible to hold with current instruments.

- Instrument is double-ended with a small and a large tip.
- Main instrument insert is metal and accepts at each end a silicone type insert.
- Working portions are designed so that silicone inserts will mechanically lock to main body portion of tips.
- Silicone tips are open-ended at both sides.
- Inserts are autoclavable.
- Inserts fix and hold the abutment once it is correctly placed.



24.751.317N

24.751.316N



47.527.00

KRASTEV Abutment Holder with **ZEPF BIONIK** Handle black and 10 silicone tips, 0.5 mm inner diameter x 1.0 mm outer diameter



47.527.01

Kit of 10 silicone tips, 0.5 mm inner diameter, 1.0 mm outer diameter. This kit is already included in article 47.527.00 KRASTEV Abutment Holding Instrument.



**PROSTHESIS LIFTER**  
BY DR. WIETZORKE

Prosthesis Lifters in ZEPF **BIONIK** Handle are available in the following colors

- 19.265.01 yellow
- 19.265.02 signal orange
- 19.265.03 red purple
- 19.265.04 signal purple
- 19.265.05 lightred-magenta
- 19.265.06 turquoise-brightblue
- 19.265.07 cobalt-blue
- 19.265.08 yellow green
- 19.265.09 grey
- 19.265.10 black



**19.265.00**

Counter display rack with 20 Prosthesis Lifters for artificial dentition, acc. to Dr. Wietzorke, in ZEPF **BIONIK** Handles



### FAST, SAFE, GENTLE

Offer your patients a real additional benefit! Especially in new telescope prostheses featuring several telescopes, the patient often has difficulties in removing the exactly fitting prosthesis for cleaning purposes.

To make matters worse, telescope prostheses can be removed by uniform loosening of all telescope crowns only. These might get jammed due to unilateral tilting. For this purpose, **HELMUT ZEPF** Medizintechnik GmbH has developed the Prosthesis Lifter for artificial dentition in co-operation with Dr. Wietzorke.



### ZEPF Retractor and Mouth Mirror

acc. to Dentist Beck

The ZEPF **BIONIK** Retractor and Mouth Mirror is available in two sizes, featuring a heart-shaped, ergonomic and highly polished design.



**37.448.10**



**37.448.20**

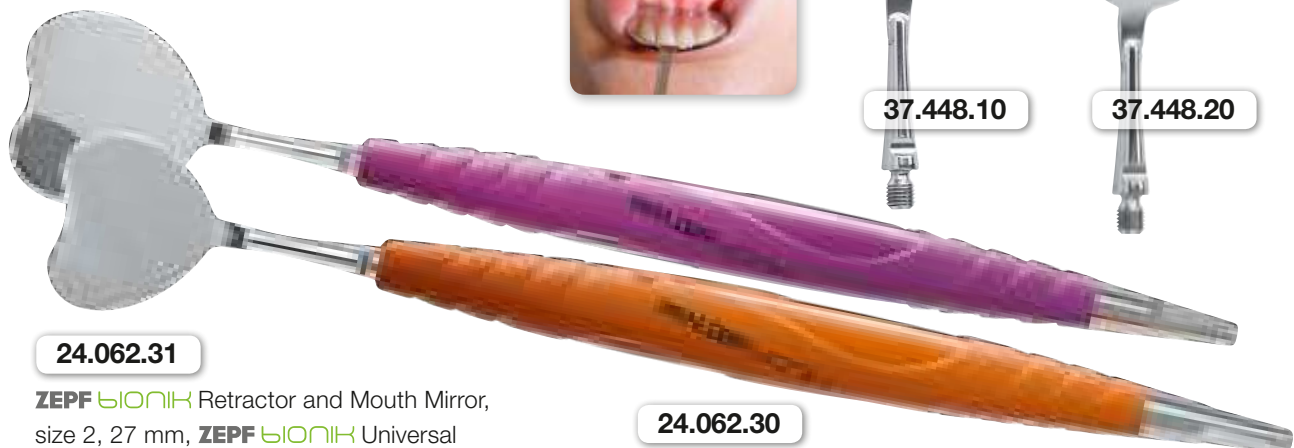

**24.062.31**

ZEPF **BIONIK** Retractor and Mouth Mirror, size 2, 27 mm, ZEPF **BIONIK** Universal Handle, PEEK, single-ended, signal purple

**24.062.30**

Size 1, 24 mm, signal orange

## Temporary Crown Remover

acc. to Dr. Hobl, in **ZEPF BIONIK** Handle

The temporary crown remover with **ZEPF BIONIK** handle features a short sickle shape.

The working tip can be adapted safely to the crown margin. The short working tips offer a very direct way to transmit the tensile force on the temporary crown, i.e. a slipping off is almost impossible.



**19.265.16** Temporary Crown Remover, double-ended, in **ZEPF BIONIK** handle, turquoise-brightblue, straight for anterior teeth, curved for posterior teeth

## Micro-composite Spatulas – superfine spatulas with **ZEPF nanopal** coating

In the case of direct composite restorations, the entire aesthetic responsibility lies in the hands of the practitioner.

With the new micro-composite spatulas in 1.1 and 1.6 mm, the practitioner is provided with highly flexible ultra-fine spatulas for precise modeling of delicate structures.

The new **ZEPF nanopal** coating offers you a very good contrast to the used material. The polished surface is easy to clean and extremely scratch resistant.



**26.120.13Ti** Micro-composite Spatula, width 1.1 mm



**26.120.13Ti** Micro-composite Spatula, width 1.6 mm



## CompoSMOOTH

THE SURFACE IS THE KEY...

acc. to Prof. Dr. med. dent. G. Krastl



Re-creating the original tooth as faithfully as possible is a challenging task for the material, the dental technician and the dentist. In case of direct composite restorations, the complete esthetic responsibility lies in the hands of the practitioner. Optimal instruments are the key to success.



The new **CompoSMOOTH**, a special silicone brush, allows an effortless adaptation and modelling of the composite surface before polymerization. Even "sticky" composites can be adapted in an optimal way. The perfect surface morphology is created almost automatically by slight pressure. The tooth shape is modeled in a way that reduces the subsequent polishing work to a minimum... and the result – optimal!

**19.202.00**

**CompoSMOOTH Complete Set** in the box incl. Washtray 1/3, with Brush Holder, 3 x 12 Soft Application Inserts and 4 Composite Instruments



**19.200.00** **CompoSMOOTH Brush Holder ZEPF-Line** with push-out function



**19.201.31** **Soft Application Inserts for layering technique**

**19.201.21** for handle 19.200.00.  
PU: 12 pieces in the box

**19.201.11**



26.120.321Ti



26.120.322Ti

**26.120.32Ti** Fissure Former Ø 1.9 mm / Ø 2.3 mm

24.751.320Ti



24.751.319Ti

**26.120.10Ti** # 1, Spatula 1.5 mm, small

26.120.121Ti



26.120.122Ti

**26.120.12Ti** Spatula 1.8 mm / Beavertail Insert 2.6 mm

24.751.323Ti



24.751.325Ti

**26.120.25Ti** # 1, Plugger Ø 1.5 mm / # 2, Plugger Ø 1.9 mm

## EASY CONTACT POINT Instruments by HELMUT ZEPF



26.123.01 3.1 mm wide, in **BIONIK** Handle, black



26.123.02 3.8 mm wide, in **BIONIK** Handle, yellow-green

**EASY CONTACT POINT Hand Instrument**  
for premolars, for perfect forming of  
contact points in MO or DO restorations



**EASY CONTACT POINT MOD Pliers**  
for perfect forming of contact points while  
preparing a composite restoration



26.122.00 MOD Pliers for premolars

26.122.10 MOD Pliers for molars



**Composites** are not easy to process. The modeling of clinically ideal contact points in particular is a big challenge for the practitioner. The Easy Contact Point Instruments will help to simplify this work step.

These instruments are available in two sizes as pliers for MOD filling, i.e. as premolar and as molar pliers.

To be used as hand instruments for MO or DO fillings. Also available in two sizes for premolars and molars.

The treatment period for a composite filling can therefore be considerably reduced.

**The related economic benefit is evident.**

## ATTIN Compo Knives

to remove composite residues in filling treatment

With the ATTIN Compo Knives in the **ZEPF BIONIK** Handle, instruments have been specially developed for removing composite filling residues. Coated with **NANOPAL** these instruments have a surface hardness of 4500 Vickers. Every dentist removes composite filling residues in different ways. Some use curettes, others excavators and sometimes scalpel blades are used. Curettes and scalers are usually too weak, i.e. there is a high risk of breakage. Scalpel blades have a high level of hardness, are correspondingly sharp and are good to use. But there are only a few angles available, so they do not allow ergonomic working.

The new ATTIN Compo Knives have addressed this requirement, i.e. strong blades manufactured at the correct angles, so all quadrants can be optimally reached.

With the new **ZEPF NANOPAL** coating, the surface has a hitherto unknown hardness.

The cutting performance is therefore guaranteed for a long period. Should an insert ever become blunt, it is easy to replace only this instrument insert.

### Advantages:

- Only two instruments for all quadrants
- **ZEPF NANOPAL** coating for maximum cutting performance and lifetime
- Instrument inserts are exchangeable
- Non-light reflecting surface



ATTIN Compo Knife for buccal and lingual surfaces, in **ZEPF BIONIK** Handle black, exchangeable inserts with **NANOPAL** coating

**24.710.010X**



ATTIN Compo Knife for mesial and distal surfaces, in **ZEPF BIONIK** Handle yellow green, exchangeable inserts with **NANOPAL** coating

**24.710.020X**





## Prosthetic Kit

Every day, you have to loosen all kinds of implant abutments in the practice / in the laboratory? In order to facilitate your work, **HELMUT ZEPF** has created a prosthetic set allowing you to loosen more than 90% of all screws available on the market.

All instruments are numbered and dispose of a RA-HEX connection. This means that these instruments can be used either in a contra-angle handpiece or in a

ratchet. Optionally, the finger ratchet can be used with an extension piece.

The set can also be completed by a torque wrench which is adjustable from 10 - 40 Ncm and has a fixation function to deactivate the torque.

The storage tray is made of stainless steel and contains a description of each individual screwdriver in order to facilitate the identification of the tools required for the respective screw.

The tray fits into a basket and can be reprocessed reliably according to the RKI guidelines.



### Advantages Prosthetic Kit



In the RA-Hex-Adapter the inserts will be picked up.



RA-Hex Adapter inserted in ratchet. Shown with demounted handle for use as finger ratchet. Information: The RA-Hex-Adapter has a rotating finger rest available (see red arrow).

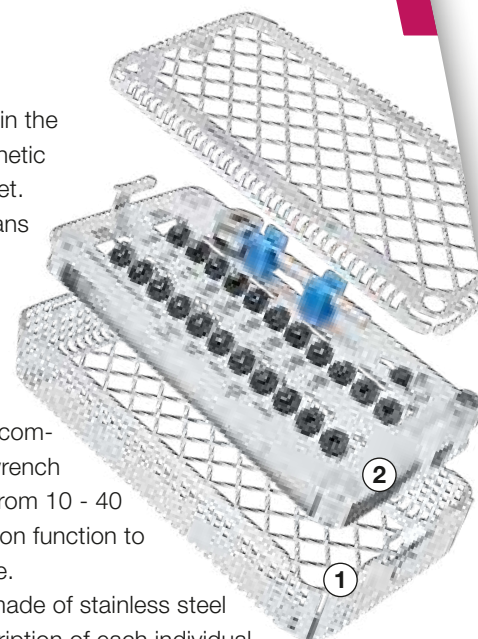

Among the recess for two RA-Hex-Adapters a socket for a comfortable removal of the screwdriver inserts from the RA-Hex-Adapter is located.

**47.830.00**

Complete Prosthetic Kit consisting of:

Shape	Screwdrivers with dental lock	short, 21 mm	long, 26 cm
	TORX T6, Straumann, Aesthura	<b>47.832.01</b>	<b>47.833.01</b>
	Universal flat 1.6 mm, narrow	<b>47.832.02</b>	<b>47.833.02</b>
	Universal flat 2.0 mm, wide	<b>47.832.03</b>	<b>47.833.03</b>
	Allen Key SW HEX 0.03", Camlog	<b>47.832.04</b>	<b>47.833.04</b>
	Allen Key SW HEX 0.05", Camlog, Sulzer (Zimmer), Semados, Biomet 3I	<b>47.832.05</b>	<b>47.833.05</b>
	Allen Key SW 0.9 mm, IMPLA, TIOLOX, BREDENT, XIVE	<b>47.832.06</b>	<b>47.833.06</b>
	Allen Key SW 1.0 mm, Ankylos	<b>47.832.07</b>	<b>47.833.07</b>
	Allen Key SW 1.2 mm, IMPLA, Nobel Biocare, Frialit, XIVE, IMZ, Biomet 3I	<b>47.832.08</b>	<b>47.833.08</b>
	Allen Key SW 1.8 mm, Ankylos	<b>47.832.09</b>	<b>47.833.09</b>
<b>1</b>	1/3 Washbasket with Lid	<b>85.192.50</b>	
<b>2</b>	Rack for Prosthetic Kit	<b>47.830.01</b>	
<b>3</b>	Driver Guide	<b>47.525.50</b>	
<b>4</b>	Ratchet with demountable handle for Prosthetic Kit	<b>47.525.55</b>	
<b>5</b>	Optional Accessory: Torque Wrench (not included in the set)	<b>47.803.02*</b>	

**ALL THE TRADEMARKS ARE THE PROPERTY OF THE RESPECTIVE COMPANIES.**

We assume no liability for deviations due to tolerances of implants.







## ZEPF Crown-Spreading Pliers

The **HELMUT ZEPF** Crown-Spreading Pliers are perfectly designed for the spreading of crowns without pressure on the root and neighbour tooth.

Sturdy, with a spring handle which holds the instrument securely in the hand. A set screw keeps the jaws in perfect alignment.

**19.277.01Z**

Crown-Spreading Pliers acc. to Bauer, modified DBGM, 14.5 cm



## Crown-Tractor Crown-Extraction Pliers with interchangeable plastic tips



Adjust the screw on the plier so that it fits nicely over the crown to be removed



After adjusting the plier, tips should be moistened with diamond powder



The crown can now be removed in a safe way

**19.274.00**

CROWN-TRACTOR Set "Exclusive" Extraction Pliers with thumbscrew detent and retaining spring, 16 cm

20 Plastic Polymer Tips,  
10 g DIATRAC adhesive powder

**19.274.01**

CROWN-TRACTOR Set "Economical" Extraction Pliers without thumbscrew detent and retaining spring, 16 cm

20 Plastic Polymer Tips,  
10 g DIATRAC adhesive powder



**19.274.13**

Replacement Kit:  
10 g DIATRAC adhesive powder, gamma irradiated and  
40 Plastic Polymer Tips



## ZEPF ENDO CUBE

acc. to Pavel Krastev DDS, patented

Never confuse your Master Gutta-Percha Cones again during the obturation phase of root canal treatment.

The ENDO CUBE is designed to be used during the obturation phase of root canal treatment. It can also be used for measurement control since the ENDO CUBE features a ruler calibrated up to 37 mm.

ENDO CUBE features the most common canal configurations found in human teeth, to include the mid-mesial often found on lower molars.

ENDO CUBE is fully autoclavable for patient safety!

### Example of use

**Step 1:** Following the instrumentation phase of root canal treatment, fit Master Gutta-Percha Cones and verify with X-Ray.

**Step 2:** Depending on doctor position relative to which tooth is being endodontically treated, select what the Orientation Marker will represent to you. Example: B, L.

Note: In case of upper molars, the marker dot always indicates palatal!

**Step 3:** Transfer Gutta-Percha Cones from tooth into ENDO CUBE exactly as they are positioned in tooth. Perform final canal irrigation and drying procedure.

**Step 4:** Coat each Master Cone with sealer and return each respective Gutta-Percha Cone back into each respective canal.



19.542.00

ENDO CUBE Master Cone Organizer,  
43 x 43 x 43 mm, CERATEF coating

19.542.01

without illustration: version in plastic material,  
black

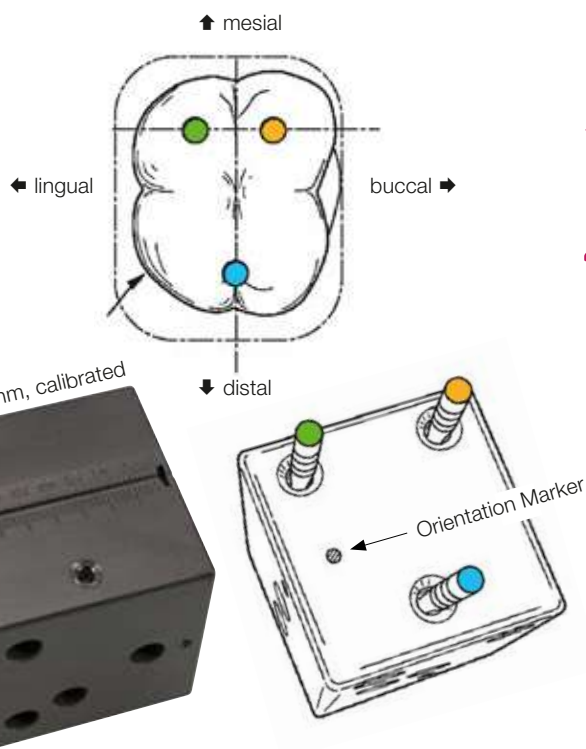

### Supplementary Instrument



22.107.21

**Anatomical Plate Forceps**  
160 mm, for secure gripping  
of the Gutta-Percha Cones

## Universal Forceps & Universal Tweezers

No treatment unit should lack these Universal **HELMUT ZEPF** Pliers and Tweezers.

They are used for securely grasping provisional plastic items, bridges, nerve instruments, impacted matrices, attaching inlays, setting interdental wedges, etc.

Usable on both upper and lower teeth. Their TC-jaws provide a secure grip.



**19.281.15TC**

All-Purpose Pliers,  
with TC insert,  
14.5 cm



**22.281.15TC**

Universal Tweezers,  
with TC insert,  
14 cm

## Nerve Canal Plier

Nerve Canal Plier for grasping fractured root-canal instruments or silver pins.

Due to the very fine concave milling groove, the instrument can be used to remove deeply fractured endodontic files, too.



**19.561.13**

Nerve Canal Plier,  
with concave milling,  
12.0 cm



DBGM

## Implant Organizer

acc. to Pavel Krastev DDS, US Patent 9,545,297 B1



### Additional Use

Bottom portion of Organizer can be additionally used during the bonding phase of porcelain veneers and/or ceramic restorations.

Dental implants are packaged in sterile vials and should be used in an as clean and organized manner as possible.

Implant therapy can be broken down into four phases: a planning phase, a surgical phase, a post-surgical phase and a restorative phase. The organizer is used during all four phases.

### 1. Planning Phase

The doctor elects an implant size for a particular site, or sites. Each planned implant size will be placed into a receptacle that corresponds to a tooth number provided on the organizer. At the end of the planning phase, all planned implants with the appropriate sizes are present in the corresponding receptacle of the implant organizer.

**Benefit:** It is assured that required implants are available for the planned surgery.

### 2. Surgical phase

The surgical assistant places the organizer with the corresponding implant vials on the countertop. When the doctor has completed the osteotomies, the surgical assistant takes the vial from the corresponding receptacle of the Implant Organizer, opens the vial and passes the implant to the doctor for insertion. Afterwards, the surgical assistant replaces the empty vial back into the implant

organizer and assists the doctor in the same manner until the procedure terminates.

**Benefit:** The doctor is not distracted from the surgical field to cross check the implant sizes since it was already done in the planning phase. Any potential confusion is eliminated.

### 3. Post-surgical phase

The importance of the post-surgical phase has to do with record keeping. In this phase the doctor makes his notes in the patient chart. It is imperative that all labels are placed according to tooth numbers in the patient record / chart! The Implant Organizer is now available for this purpose. All vial labels can be removed and inserted into the patient chart.

**Benefit:** Avoiding of errors during record keeping.

### 4. Restorative Phase

The bottom of the implant organizer is manufactured with much lower profile and with solid bottoms, magnetically attached. It should be used during the restorative phase of implantology. In this manner as the doctor removes healing abutments from the patient's mouth they can be placed into the implant organizer according to tooth numbers.

**Benefit:** A mix-up of healing caps / abutments is avoided because all parts are assigned to an explicit tooth.





## Implant Organizer

acc. to Pavel Krastev DDS, US Patent 9,545,297 B1

The Implant Organizer consists of a right half (for quadrant 1 and 4 [REF 47.985.00](#)) and a left half (for quadrants 2 and 3 [REF 47.985.01](#)). Organizer features tooth numbers designated by the Universal Numbering System and the European (Palmer) Numbering System. When a full arch case is performed (guided surgery or not), both halves of the organizer are used. When working on either right or left side of patient, respective half can be used.

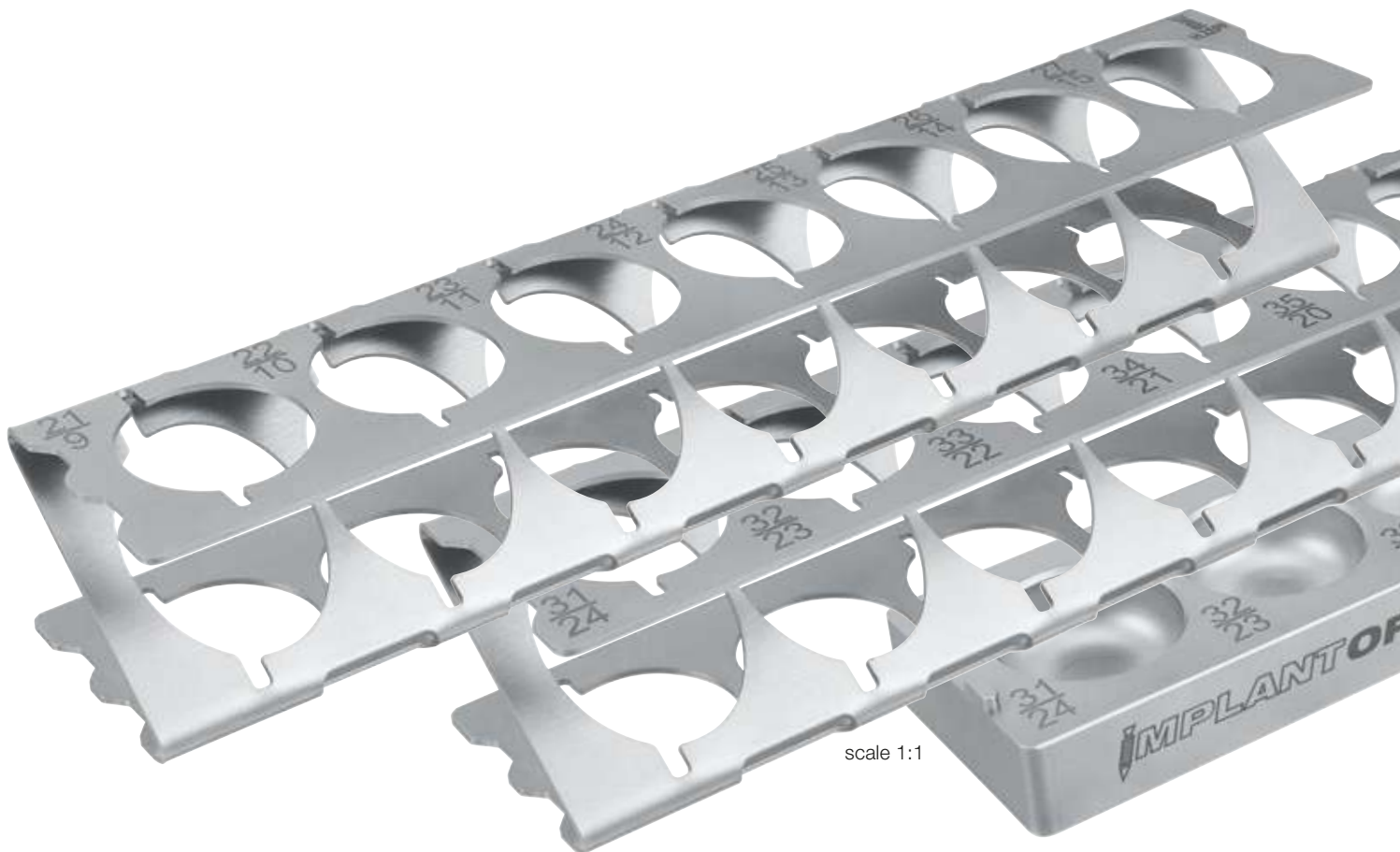
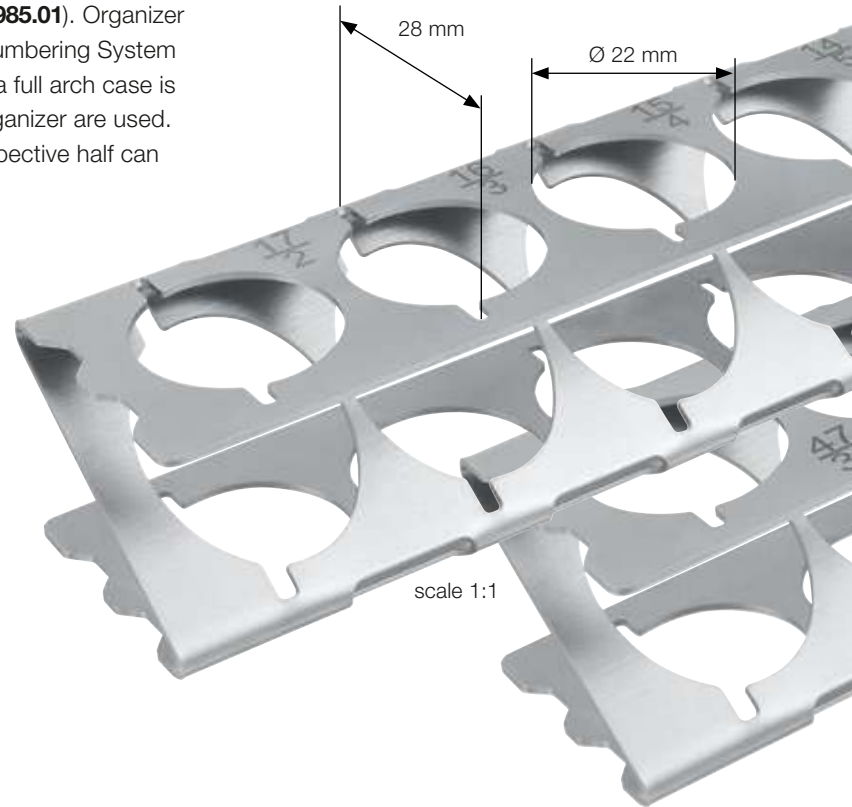



47.985.00



Quadrant 1 / 4

Implant Organizer, stainless steel,  
rack to organize the implants to be  
inserted



47.985.01



Quadrant 2 / 3

Implant Organizer, stainless steel,  
rack to organize the implants to be  
inserted



ZEPF care  
SYSTEM

## Advantages

- The meshes of the bottom and the lid are designed in a broad shape. Consequently dead zones are minimized.
- The diagonal profile of the mesh simplifies the identification of the parallel arranged instruments in the profile.
- The meshes on the edge of the tray are designed in a narrow shape and thus enhance the stability of the basket.
- The risk of injury is reduced.

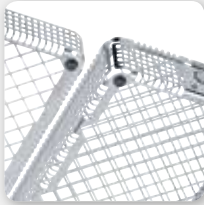

## Washtrays

1/3 178 x 90 x 24

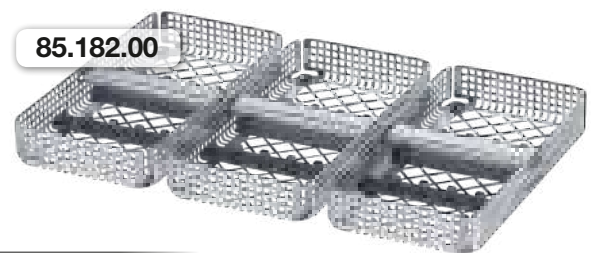

1/2 178 x 135 x 24

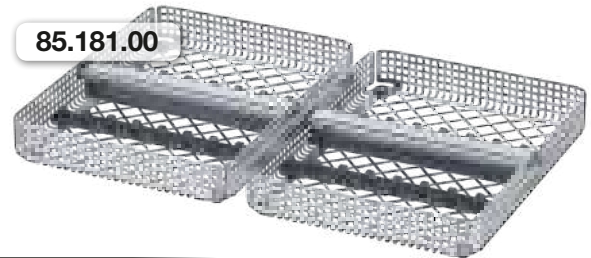

1/1 275 x 178 x 24

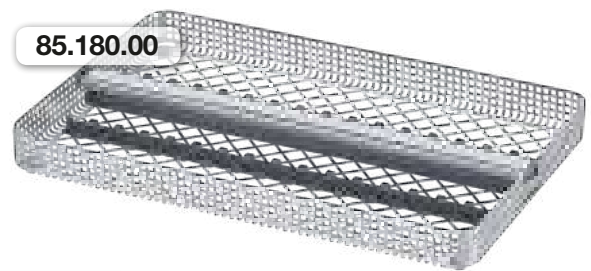

1/1 275 x 178 x 24



Profile, high, individual







### Washbaskets



85.192.50

1/3 178 x 90 x 37



85.194.00

1/2 178 x 135 x 37

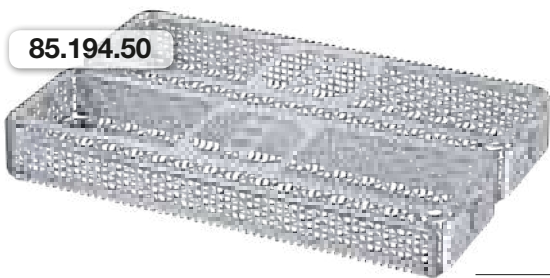

85.194.50

1/2 275 x 86 x 37

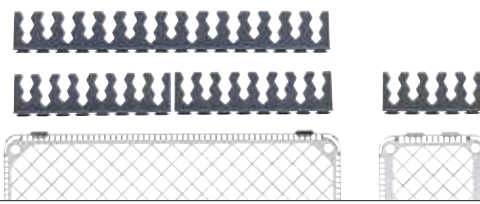

85.195.00

1/1 275 x 178 x 37

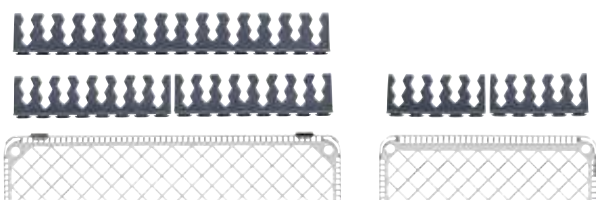

Profile, low

1/1

85.180.03

85.180.04

85.180.05

1/2

1/3

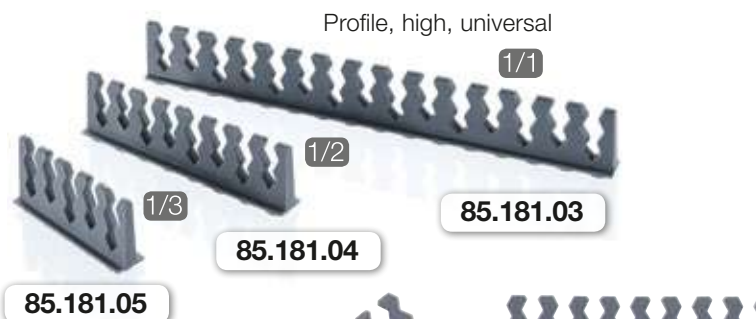

Profile, high, universal

1/1

85.181.03

85.181.04

85.181.05

1/3

1/2



Press Pad

1/1

85.182.03

85.182.04

85.182.05

1/2

1/3



85.182.08

Lid Instrument Fixation to fix scissors / needle holders in the washbasket





**ZEPF** Medizinbecher**85.252.25**

Medicine Cup, stainless steel,  
Ø 60 mm x 27 mm high,  
25 ccm

**85.251.04**

Medicine Cup, stainless steel,  
with plastic lid,  
Ø 40 mm x 30 mm high

**85.251.03**

Medicine Cup, stainless steel,  
with plastic lid,  
Ø 40 mm x 25 mm high





## CMF SYSTEM

CRANIO MAXILLOFACIAL FRACTURE SYSTEM



For detailed information just  
**scan!**  
or request our product flyer  
on the internet at  
[www.zepf-dental.com](http://www.zepf-dental.com).

**CMF Box "big"**  
for Screw Systems

-  Ø 1.0 mm
-  Ø 1.2 mm und
-  Ø 1.5 mm



**ZEPF** Screwdriver Handle, with blade





HELMUT ZEPF  
1921-2021



HELMUT ZEPF  
1921-2021

**ZEPF** | dental  
essentials

AESTHETIC IS THE RESULT

[zepf-dental.com](http://zepf-dental.com)

100 YEARS MADE IN GERMANY

ZEPF|essentials K21/1E