



# FULL MONTESSORI BIRCH FLOOR BED

ASSEMBLY & USE GUIDE



Freedom of Movement



We believe that children deserve spaces that help them thrive.

*Clark Davis*

Clark Davis, Founder

Thank you for choosing Sprout! As parents ourselves, we know the care and consideration that goes into selecting something for your child. We appreciate your trust in allowing us to be a part of your space! We hope that these resources will serve your family for years to come.



Promotes freedom of movement



Design inspired by the Montessori Method



Made to grow with your little one

# We're Here to Support You



Please reach out to our support team if you need any assistance along the way!



+1 (833) 530-0033



M-F 8-4 MST



support@sprout-kids.com

## Assembly Instructions

### Included Parts



Batten

**A**

Side\* (x2)

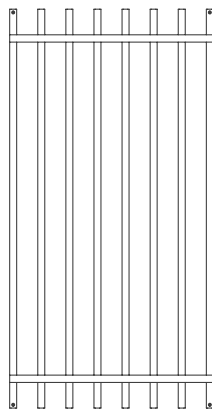

**B**

Slat Roll (x2)

**\*Combination of Low, High, or Scoop Sides, depending on your order**

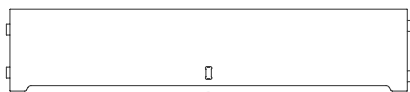

**C**

Ends (x2)



**D**

End Slats (x2)



**E**

Phillips  
Screws (x8)



**F**

Phillips Bit



**G**

Rib

## Low Position Assembly



1. With the “Groove” facing the “Notch”, push Tab into Slot until it “pops” in place.

2. Apply force on part to secure.

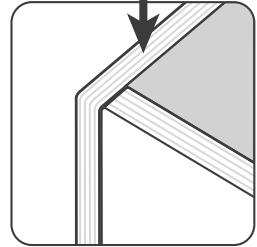
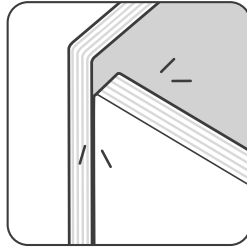
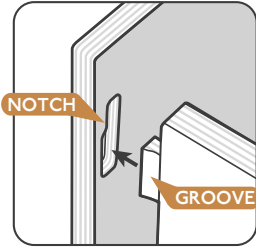

1

Insert tabs on End **C** into slots on Side **A** in the orientation shown.

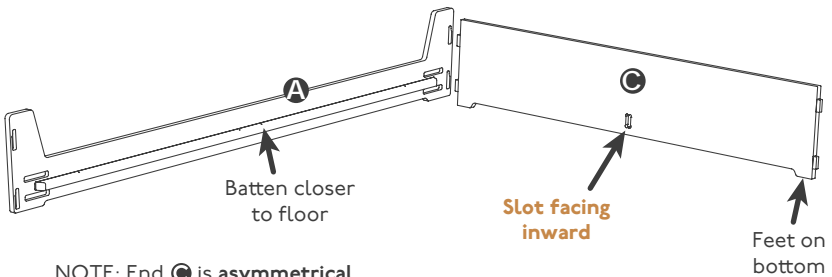

NOTE: End **C** is **asymmetrical** and will only assemble in the correct orientation.

2

Push down Side **A** to tighten.

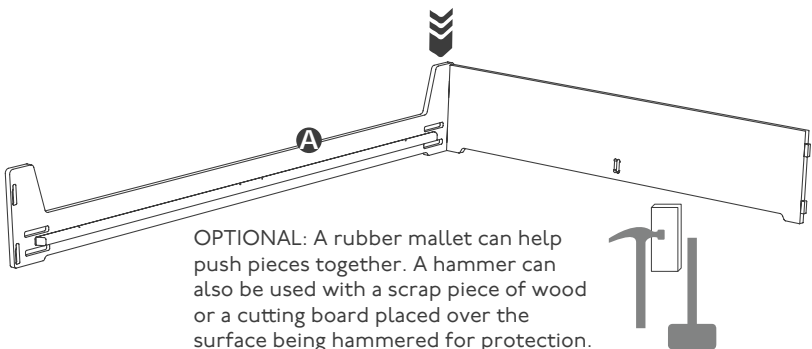

OPTIONAL: A rubber mallet can help push pieces together. A hammer can also be used with a scrap piece of wood or a cutting board placed over the surface being hammered for protection.

3

Repeat Steps 1 & 2 for opposite End **C**.

- 4** On a **carpeted surface**, lift up frame onto Side **A**, as shown. Then insert both End Slats **D** into slots indicated.

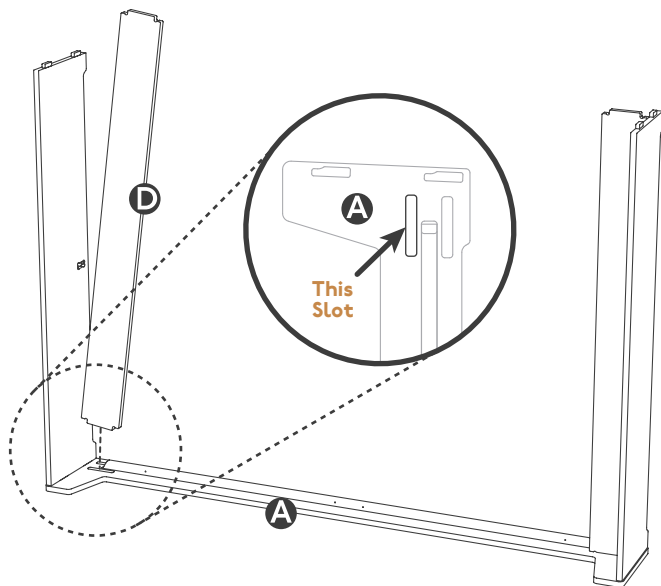

- 5** Place opposite Side **A** onto tabs on Ends **C** and End Slats **D**. Make sure to “pop” the slots over the tabs on Ends.

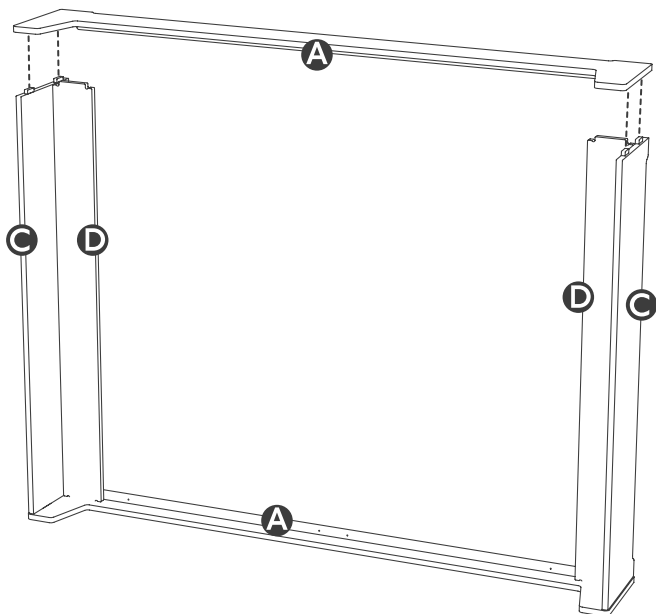

- 6** Carefully lay bed back down, then tighten both ends of the second Side **A** as shown.

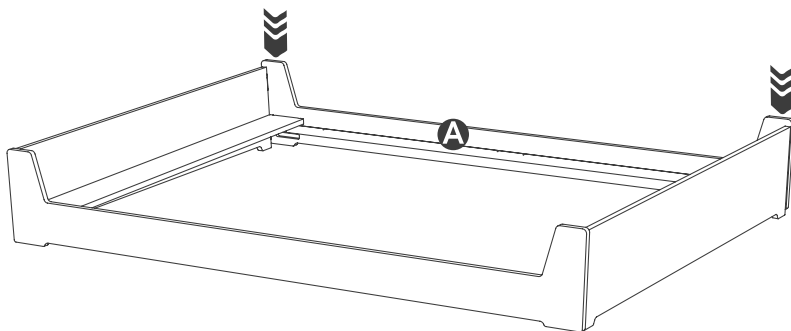

- 7** With webbing on top, align the Slat Roll **B** holes with the holes in the batten of Side **A**, as shown.

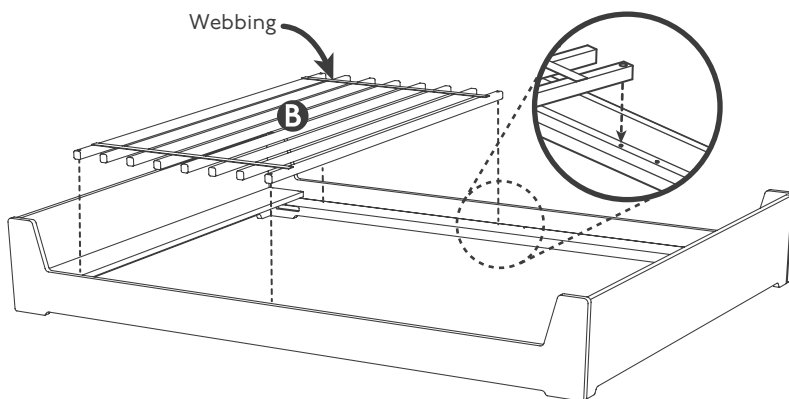

- 8** One at a time, insert Phillips Screw **E** through the holes in Slat Roll **B** into the holes in the batten of Sides **A**. Tighten down the screws with a screwdriver or a drillgun using the supplied Phillips Driver **F**.

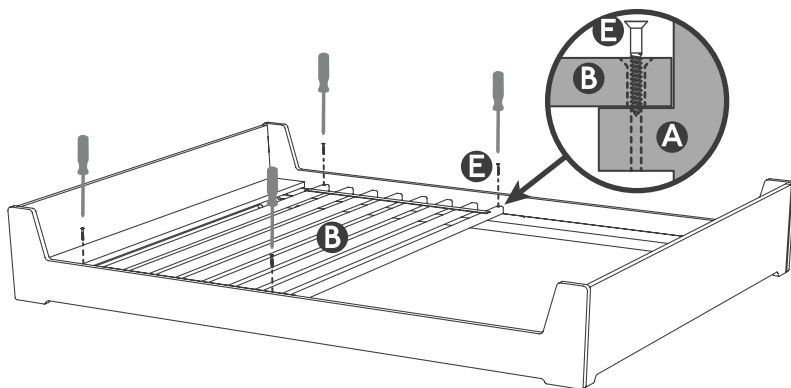

- 9** Repeat Steps 7 & 8 with the other Slat Roll **B**.

- 10** Lift frame up onto Side **A**, then insert end of Rib **G** into slot on End **C** while holding Rib at an angle. Then rotate opposite end of Rib **G** down until it pops into its slot. You are done!

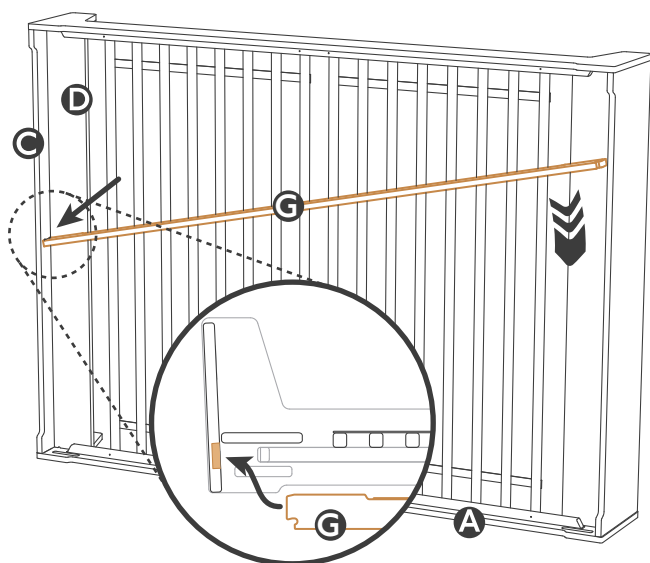

## Changing from Low to High Position

- 11** Using a screwdriver or a drillgun with Phillips Driver **F**, remove all (8) Phillips Screws **E**. Then remove the two Slat Rolls **B**.

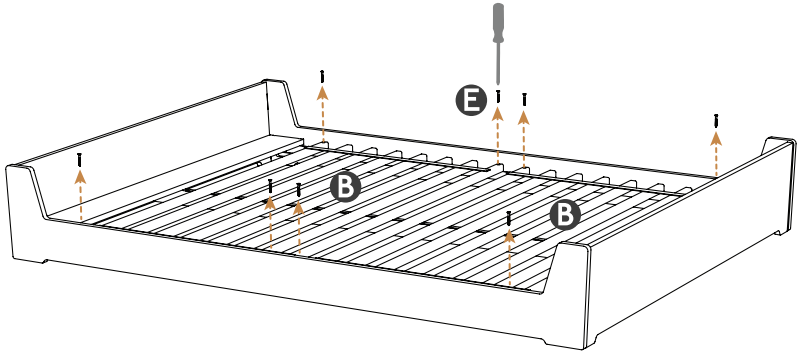

- 12** Place a piece of wood or hardbound book under the foot of Side **A**, as shown, then press down on the top of Ends **C** to loosen. Do this for both ends of a single Side **A**.

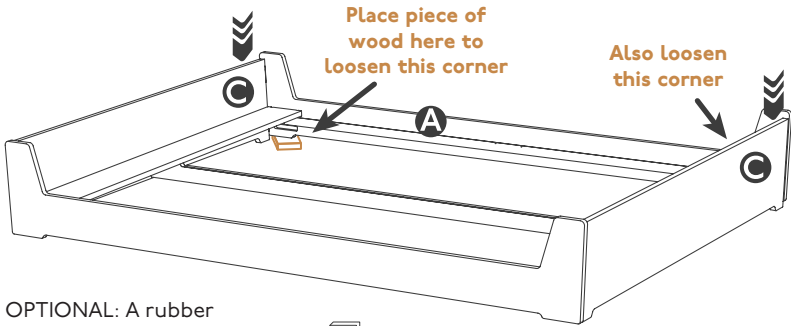

OPTIONAL: A rubber mallet can help push pieces apart. A hammer can also be used with a scrap piece of wood or a cutting board placed over the surface being hammered for protection.





13

On a **carpeted surface**, lift up the frame onto the tightened Side **A**, then remove the Side **A** that you loosened and Rib **G**.

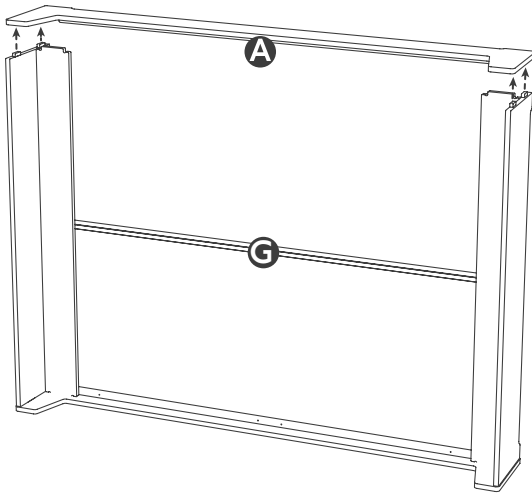

14

Carefully move End Slat **D** from its current slot to the slot on the opposite side of the batten, as shown. Repeat for other End Slat **D**.

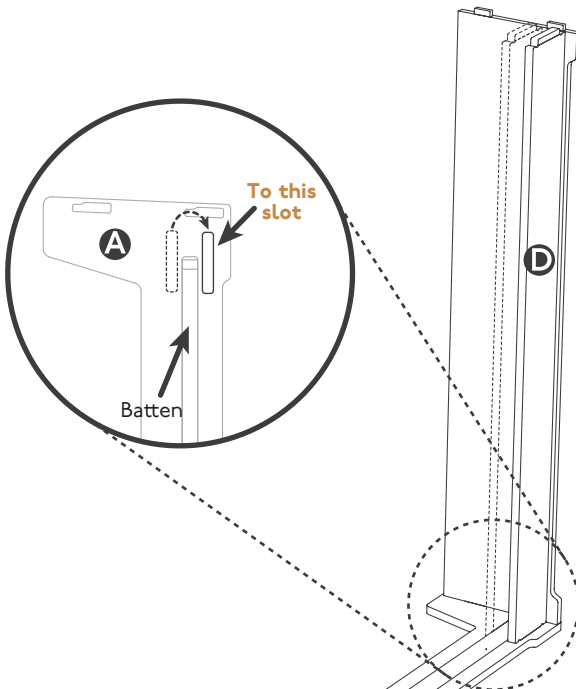

- 15** Replace Side **A** onto the bed frame, making sure to pop the slots over the tabs on Ends.

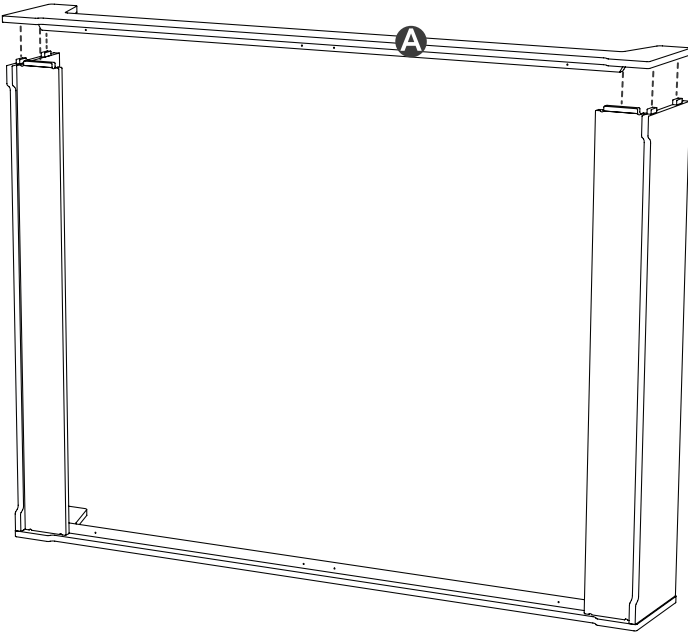

- 16** Carefully lay frame back down as shown, then tighten both Ends **C** as shown.

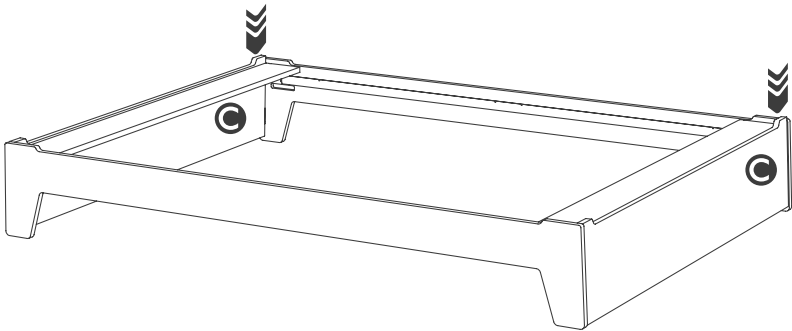

- 17** Reattach Slat Rolls **B** onto the top of the battens of Sides **A**, as shown, installing per Steps 7-9.

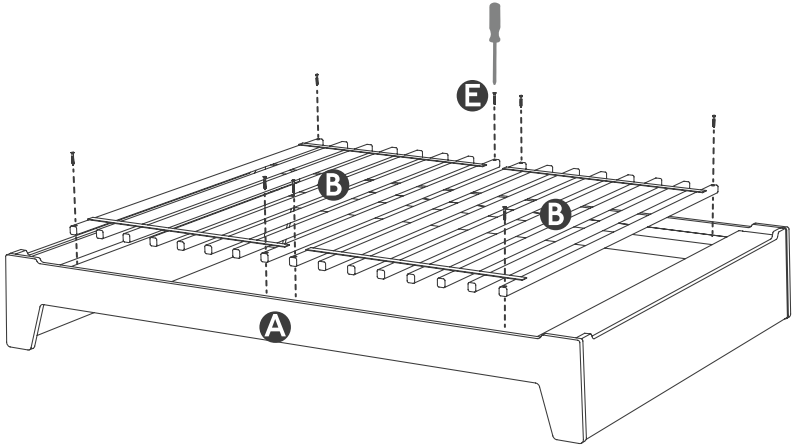

- 18** Lift frame up onto Side **A**, then insert end of Rib **G** into slot on End **C** while holding Rib at an angle. Then rotate opposite end of Rib **G** down until it pops into its slot. You are done!

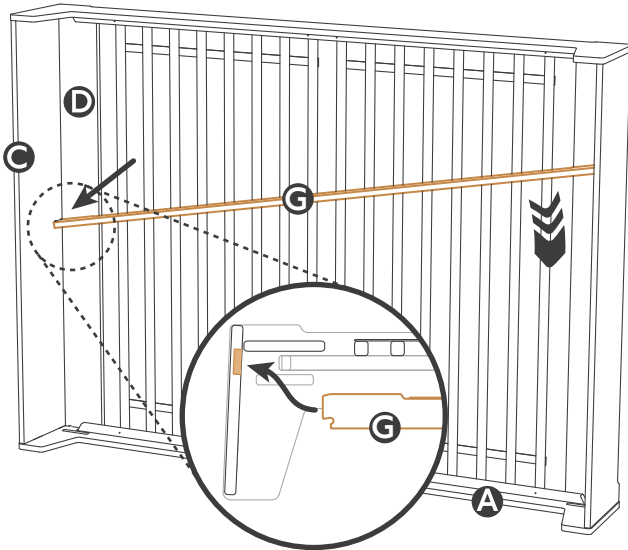

# Safety Information

---

When it comes to your child's sleep, safety is our top priority! Since you know your child best, we invite you to adapt your child's space based on their unique needs and abilities. With that in mind, here are some safety recommendations we encourage you to consider:



For children under 18 months, we recommend that you **do not place the Low Side or Scoop Side closer than 12"** from the wall. Meanwhile, the **High Side** should be **less than 1.5"** or greater than 12" from the wall.



With your child's increased freedom of movement, be aware of other potential dangers in your child's room. You may want to secure other pieces of furniture to the walls, move blind cords out of reach, cover all electrical outlets, and consider general safety precautions.



There are different age recommendations for items that can be in the bed with your child. **Please scan the QR code below to read more.**



[sprout-kids.com/FB](https://sprout-kids.com/FB)



# Making the Transition

---

Transitioning to a “big kid bed” can be an exciting time for parents and children alike! Here are some things that may help as you make the change:

- A new bed can be a big change and, for a time, it may disrupt your child’s rhythm. It can be helpful to make the changes when there aren't any other major changes in your home (such as a new baby, moving, etc.).
- A familiar comfort item like a blanket or stuffed animal can help bring a sense of normalcy to your child.
- It can help to keep the rest of their bedtime routine and bedroom setup as similar as possible so your child knows what to expect, even if their bed is different.
- There can be a learning curve for children as they learn to maneuver around any piece of furniture in the home. You can observe (by being in the room or with a baby camera) then guide and model to your child as they navigate their new bed in their environment.





Some of the best things in life can take time, and the same is true when it comes to learning to sleep independently. Read about how Grant transitioned to his new bed:

“ It took two months before our son actually slept in his bed. He used to sleep on the floor next to the door! We transitioned to a floor bed when we moved into a new apartment, so I think he was just nervous about all of the changes. One day, my husband fell asleep on our son's bed while watching him and from that point on, Grant has slept in his floor bed! ”



- Katie, mother of one

## Proper Care & Use

---

In order to maintain the quality of your product, we recommend following these basic guidelines:



Avoid letting liquid sit on your wooden product. Wipe it dry to avoid water damage.



Abrasive brushes and cleaners will remove the finish on your product. Use soft cloths only.



A mixture of water and vinegar will clean most messes. Scrub gently with a soft cloth.

## Designed for Growth

---

This floor bed is designed to grow with your child. As they get older, they might feel safer and more comfortable with the bed in the raised position. Follow your child's lead in knowing when they're ready to elevate their floor bed; then, follow the assembly instructions to reassemble the bed in the raised position.

Want to dive deeper with additional  
Floor Bed resources?

Scan the QR code to learn more!



[sprout-kids.com/FB](https://sprout-kids.com/FB)

# A Prepared Environment

---

Thoughtfully preparing a child's environment can encourage them to explore freely. When a child has a safe space to test their limits, their confidence can grow and they can gain a better understanding of their world. Here are some other items that you might consider as you cultivate a prepared environment in your home:



The **Alba Montessori Children's Wardrobe** allows children to dress and care for themselves more independently. A limited number of weather-appropriate options can be presented for a less overwhelming experience for them.

If you're hoping to increase your child's interest in books, adding a **Lexico Book Display Shelf** can be a great option. When presented this way, they can explore the covers and better choose what they want to read.



## Let's Be Friends

---

Join the community by following **Sprout on Instagram!** We frequently share inspiring and informative experiences from parents like you, educational tips from Montessori-trained professionals, and updates about new products and how they can be used in your home.



@sprout\_kids



hey@sprout-kids.com



sprout-kids.com