

SOSTA BED  
**PLATFORM & LEGS**  
ASSEMBLY GUIDE

**PARTS**

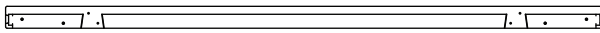

**A** (2x)

Side

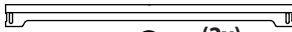

**B** (2x)

End

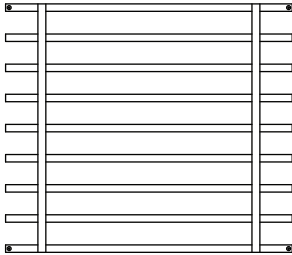

**C** (2x)

Slat Roll

Included if you purchased legs

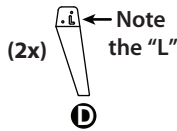

(2x)

**D**

Left Leg



(2x)

**E**

Right Leg



(12x)

**F**

Phillips Screw

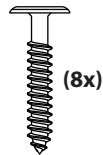

(8x)

**G**

1.6" Hex Screw

**INCLUDED TOOLS**



4mm Hex  
Wrench



Hex  
Bit



Phillips  
Bit

**REQUIRED**



Phillips  
Screwdriver

OR



Power  
Drill

## ASSEMBLY VIDEO ►

Enjoy the best assembly experience  
[sprout-kids.com/platform](http://sprout-kids.com/platform)



- 1** Lay out (2x) Sides **A** and (2x) Ends **B** as shown.

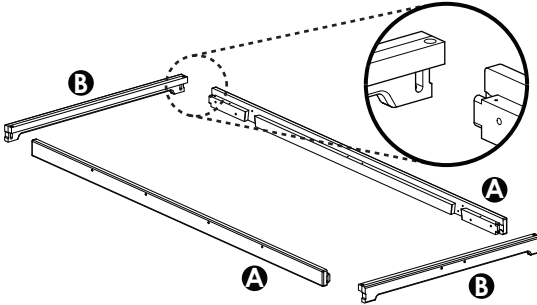

- 2** Starting with one End **B**, fully insert tabs of Sides **A** into slots on Ends **B** until flush. Repeat with other End **B**.

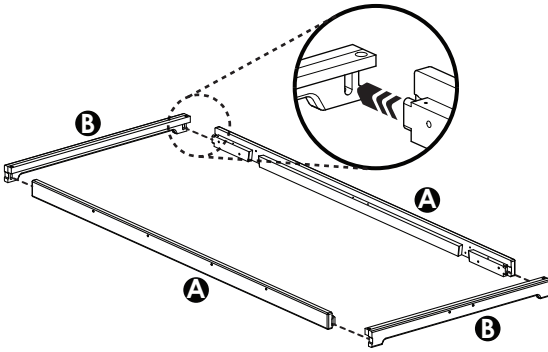

OPTIONAL: A rubber mallet can help push pieces together. A hammer can also be used with a scrap piece of wood or a cutting board placed over the surface being hammered for protection.

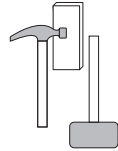

- 3** Screw a Phillips Screw **F** into corner of End **B** and Side **A**. Repeat with each corner.

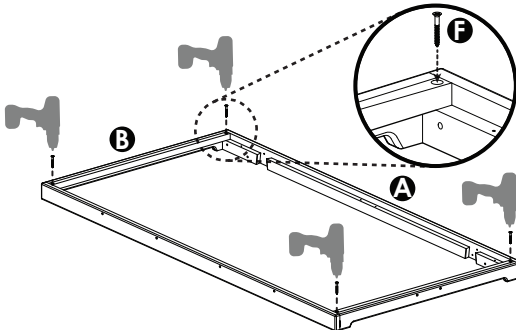

## ADDING LEGS



If you didn't purchase legs, proceed to **10**.

**4** Flip frame over.

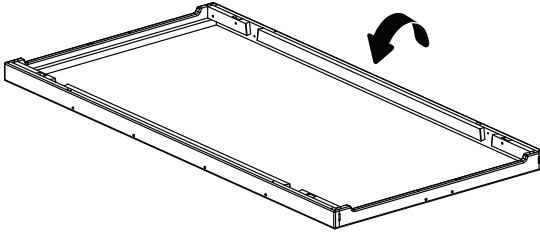

**5** If using a drill, set clutch on drill to **LOW SETTING** (around 3).

If your drill has two speeds, set it to the **SLOW SPEED** (1).

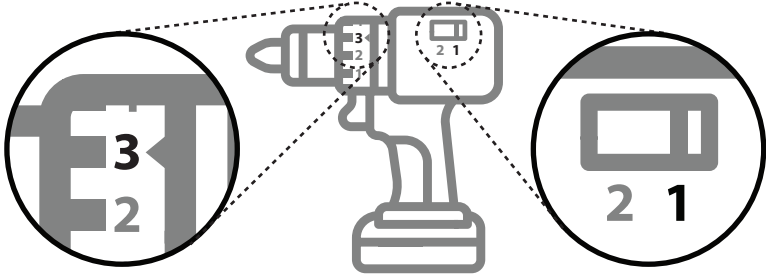

**A high clutch setting will strip screw heads and render parts useless!**

**CLUTCH TOO HIGH:** If the drill twists dramatically in your hand when drilling. Lower the clutch setting.

**CLUTCH TOO LOW:** If the screw does not screw in all the way. Adjust clutch up by 1 setting and try again.

**6** Slide the (2x) Left Legs **D** into Sides **A** at opposite corners as shown.

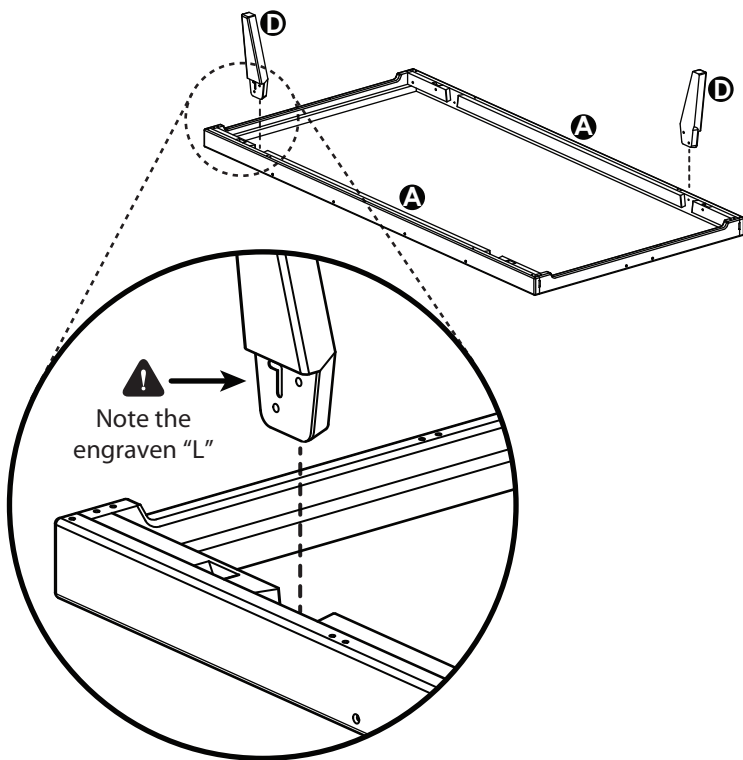

**!** When adding legs, ensure they point away from the center of the bed.



**7** Screw the (4x) 1.6" Hex Screws **C** in the (2x) Left Legs **D**.

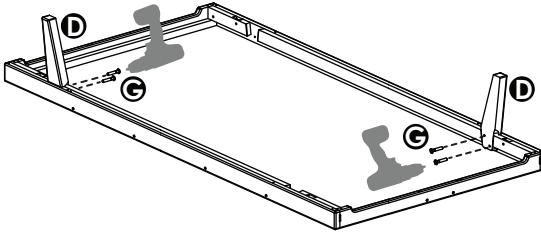

**8** Repeat steps 6 - 7 with the (2x) Right Legs **E**.

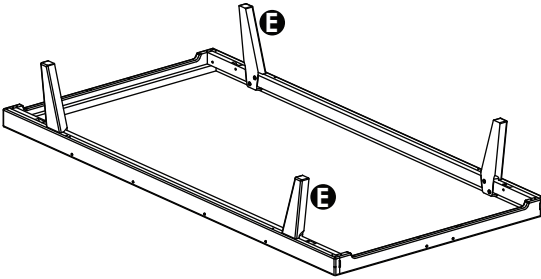

**9** Flip frame over.

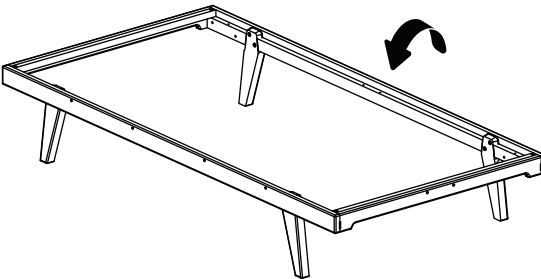

## ADDING SLAT ROLLS

- 10** With webbing face up, align the Slat Roll **C** holes with the Holes in Side **A** as you lay one of the Slat Rolls **C** onto one half of the bed frame.

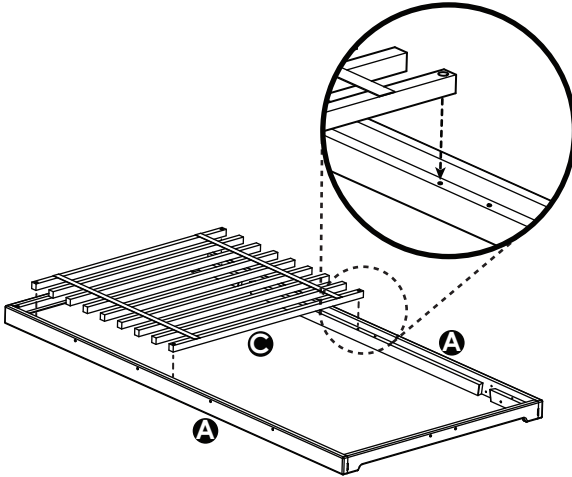

- 11** Insert the tips of (2x) Phillips Screws **F** through the Slat Roll **C** holes and vertically into the holes of Side **A**.

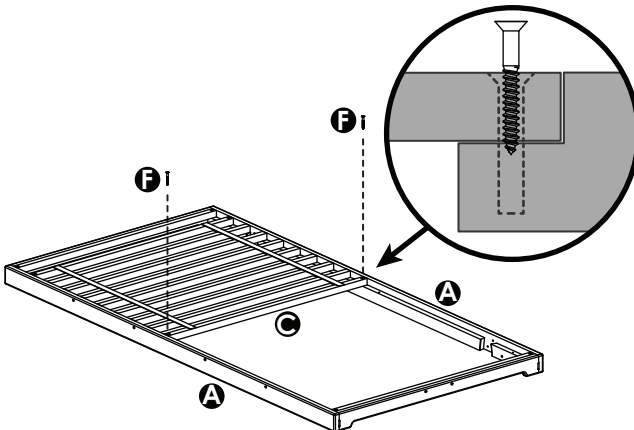

- 12** Screw the (2x) Phillips Screws **F** into the holes on the side of the Slat Roll **C** near the middle of the bed.

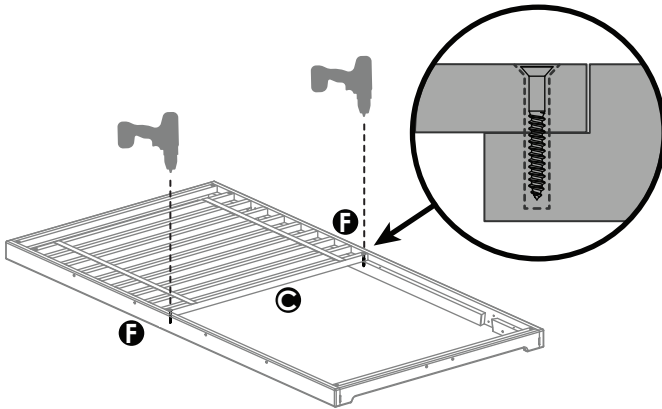

- 13** Set the tips of the additional (2x) Phillips Screws **F** through the other Slat Roll **C** holes and screw them into the holes of Side **A**.

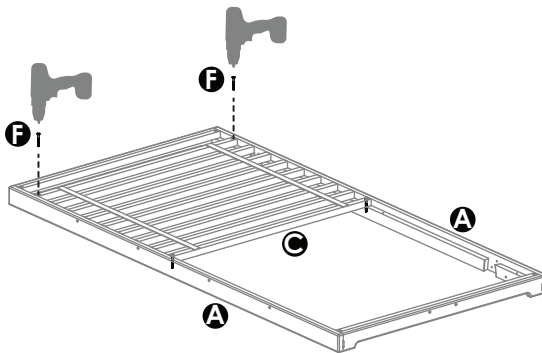

**14** Repeat steps 10-13 to attach remaining Slat Roll **C**.

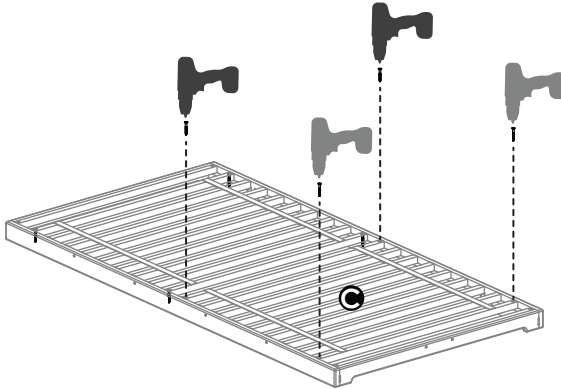

**!** **AVOID ENTRAPMENT**, which can cause serious injury or death, by placing bed more than 12" away from any wall. Those under the age of 3 may be at greater risk.

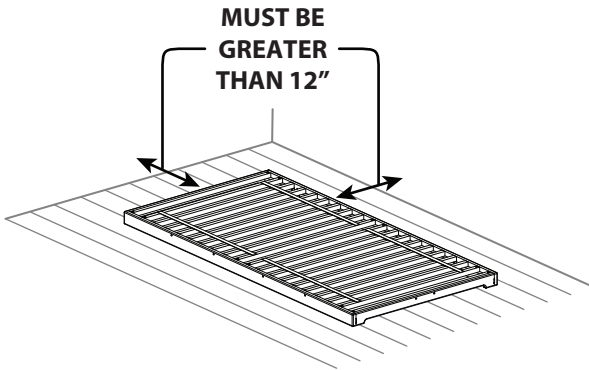

**15** For additional Safety Regulations and Standards:  
[sprout-kids.com/sosta/safety](http://sprout-kids.com/sosta/safety)



If you have questions, reach out to [support@sprout-kids.com](mailto:support@sprout-kids.com)