

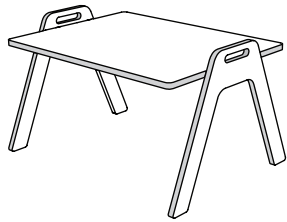

Cultivate Resilience



CHOWKI FLOOR TABLE

PARTS

A Legs (2)

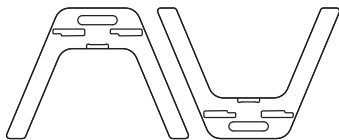

B Top and brace (1)

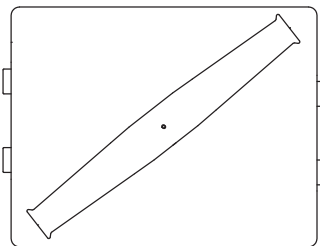

1 Insert the tabs of the Top **B** into the slots on one Leg **A**.

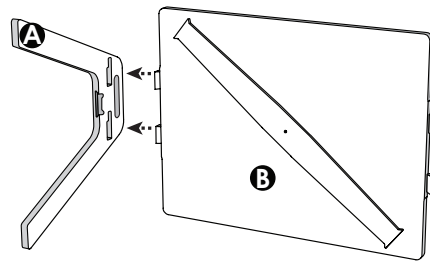

2 Push down on Leg **A** to lock.

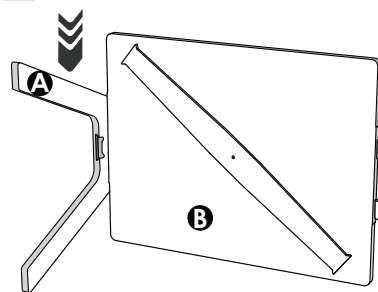

3 Rotate assembly 180°. Repeat step 1-2 with the second Leg **A**.

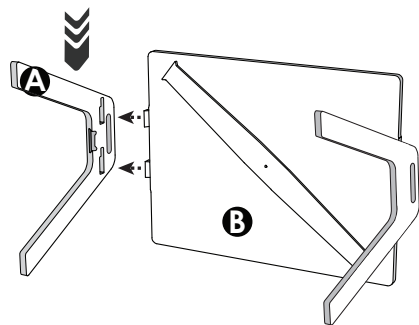

4 Carefully bend up both ends of the Brace **B**.

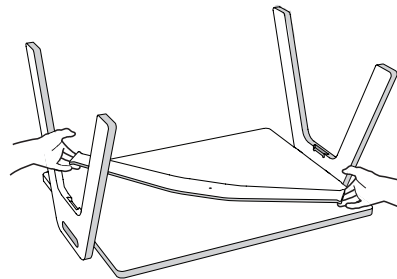

5 Rotate and insert ends of Brace **B** into slots on underside of Legs **A**.

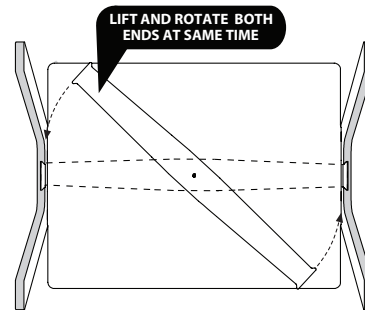

! We recommend stacking no more than 4 Chowkis at a time.

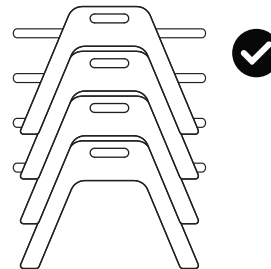

NEED HELP?



+1 (833) 530-0033
support@sprout-kids.com
Available M-F 8-4 MST

WARRANTY

Learn about your warranty.
sprout-kids.com/warranty



CARE

Learn to care for your Chowki with our detailed guide.
sprout-kids.com/cleaning



Use mild cleaners only



Use a damp cloth & wipe dry

INSPIRE SOMEONE

We'd love to see your Chowki in action! If you choose to share a picture or video with your new table, tag or DM us.

@sprout_kids

SHARE YOUR THOUGHTS

You're invited to join the Sprout Advisory Board and help shape future products.
sprout-kids.com/board

