

L76 Series

Hardware Design

GNSS Module Series

Rev. L76_Series_Hardware_Design_V3.1

Date: 2016-05-18



Our aim is to provide customers with timely and comprehensive service. For any assistance, please contact our company headquarters:

Quectel Wireless Solutions Co., Ltd.

Office 501, Building 13, No.99, Tianzhou Road, Shanghai, China, 200233

Tel: +86 21 5108 6236

Email: info@quectel.com

Or our local office. For more information, please visit:

<http://www.quectel.com/support/salesupport.aspx>

For technical support, or to report documentation errors, please visit:

<http://www.quectel.com/support/techsupport.aspx>

Or email to: Support@quectel.com

GENERAL NOTES

QUECTEL OFFERS THE INFORMATION AS A SERVICE TO ITS CUSTOMERS. THE INFORMATION PROVIDED IS BASED UPON CUSTOMERS' REQUIREMENTS. QUECTEL MAKES EVERY EFFORT TO ENSURE THE QUALITY OF THE INFORMATION IT MAKES AVAILABLE. QUECTEL DOES NOT MAKE ANY WARRANTY AS TO THE INFORMATION CONTAINED HEREIN, AND DOES NOT ACCEPT ANY LIABILITY FOR ANY INJURY, LOSS OR DAMAGE OF ANY KIND INCURRED BY USE OF OR RELIANCE UPON THE INFORMATION. ALL INFORMATION SUPPLIED HEREIN IS SUBJECT TO CHANGE WITHOUT PRIOR NOTICE.

COPYRIGHT

THE INFORMATION CONTAINED HERE IS PROPRIETARY TECHNICAL INFORMATION OF QUECTEL CO., LTD. TRANSMITTING, REPRODUCTION, DISSEMINATION AND EDITING OF THIS DOCUMENT AS WELL AS UTILIZATION OF THE CONTENT ARE FORBIDDEN WITHOUT PERMISSION. OFFENDERS WILL BE HELD LIABLE FOR PAYMENT OF DAMAGES. ALL RIGHTS ARE RESERVED IN THE EVENT OF A PATENT GRANT OR REGISTRATION OF A UTILITY MODEL OR DESIGN.

Copyright © Quectel Wireless Solutions Co., Ltd. 2016. All rights reserved.

About the Document

History

Revision	Date	Author	Description
1.0	2013-02-08	Ray XU	Initial
1.1	2013-03-21	Ray XU	<ol style="list-style-type: none"> Deleted PMTK 291 command. Changed R3 to 100R in figure 17. Updated chapter 2.4. Changed typical voltage of V_BCKP to 3.3V.
1.2	2014-05-10	Tony GAO	<ol style="list-style-type: none"> Modified the input power at RF_IN. Changed the tracking sensitivity to -165dBm.
1.3	2014-06-11	Ray XU	Updated packaging information.
2.0	2014-08-28	Tony GAO	<ol style="list-style-type: none"> Added related information of L76B module. Added the description of power supply requirement.
2.1	2015-11-11	Neil WU	<ol style="list-style-type: none"> Added the description of PPS VS. NMEA. Added the information about L76G module.
3.0	2016-04-26	Storm BAO	<ol style="list-style-type: none"> Deleted the information about L76G module. Added the information about L76-L module. Added chapter 3.9: EPO Data Service
3.1	2016-05-18	Storm BAO	Added the description of I2C about L76-L module.

Contents

About the Document	2
Contents	3
Table Index	5
Figure Index	6
1 Introduction	7
2 Product Concept	8
2.1. General Description.....	8
2.2. Key Features.....	9
2.3. Block Diagram.....	10
2.4. Evaluation Board.....	10
2.5. Protocols Supported by the Module.....	11
3 Application	12
3.1. Pin Assignment.....	12
3.2. Pin Definition.....	12
3.3. Power Supply.....	14
3.4. Operation Modes.....	15
3.4.1. Full on Mode.....	16
3.4.2. Standby Mode.....	17
3.4.3. Backup Mode.....	18
3.4.4. Periodic Mode.....	19
3.4.5. AlwaysLocate™ Mode.....	21
3.5. Reset.....	22
3.6. UART Interface.....	23
3.7. I2C Interface.....	25
3.8. EASY Technology.....	26
3.9. EPO Data Service.....	26
3.10. Multi-tone AIC.....	26
3.11. ANTON.....	27
3.12. LOCUS.....	27
3.13. PPS VS. NMEA.....	27
4 Antenna Interfaces	29
4.1. Antenna Specifications.....	29
4.2. Recommended Circuit for Antenna.....	30
4.2.1. Active Antenna.....	30
4.2.1.1. Active Antenna without ANTON.....	30
4.2.1.2. Active Antenna with ANTON.....	31
4.2.2. Passive Antenna.....	32
4.2.2.1. Passive Antenna without External LNA.....	32
4.2.2.2. Passive Antenna with External LNA.....	32

5	Electrical, Reliability and Radio Characteristics	34
5.1.	Absolute Maximum Ratings	34
5.2.	Operating Conditions	35
5.3.	Current Consumption	35
5.4.	Reliability Test	36
6	Mechanical Dimensions	37
6.1.	Mechanical Dimensions of the Module	37
6.2.	Bottom Dimensions and Recommended Footprint.....	38
6.3.	Top and Bottom View of the Module	39
7	Manufacturing, Packaging and Ordering Information	40
7.1.	Assembly and Soldering	40
7.2.	Moisture Sensitivity	41
7.3.	ESD Protection.....	41
7.4.	Tape and Reel Packaging	42
7.5.	Ordering Information	43
8	Appendix References	44

Quectel
Confidential

Table Index

TABLE 1: L76 SERIES PRODUCTS	7
TABLE 2: KEY FEATURES	9
TABLE 3: PROTOCOLS SUPPORTED BY THE MODULE	11
TABLE 4: PIN DESCRIPTION	12
TABLE 5: MODULE STATE SWITCH	15
TABLE 6: DEFAULT CONFIGURATION	16
TABLE 7: PMTK COMMAND FORMAT	19
TABLE 8: RECOMMENDED ANTENNA SPECIFICATIONS	29
TABLE 9: ABSOLUTE MAXIMUM RATINGS	34
TABLE 10: POWER SUPPLY RATINGS	35
TABLE 11: CURRENT CONSUMPTION	35
TABLE 12: RELIABILITY TEST	36
TABLE 13: REEL PACKAGING	42
TABLE 14: ORDERING INFORMATION	43
TABLE 15: RELATED DOCUMENTS	44
TABLE 16: TERMS AND ABBREVIATIONS	44

Quectel
Confidential

Figure Index

FIGURE 1: BLOCK DIAGRAM.....	10
FIGURE 2: PIN ASSIGNMENT	12
FIGURE 3: INTERNAL POWER CONSTRUCTION	15
FIGURE 4: RTC SUPPLY FROM NON-CHARGEABLE BATTERY	18
FIGURE 5: REFERENCE CHARGING CIRCUIT FOR RECHARGEABLE BATTERIES	19
FIGURE 6: PERIODIC MODE	21
FIGURE 7: ALWAYSLOCATE™ MODE.....	22
FIGURE 8: REFERENCE RESET CIRCUIT USING OC CIRCUIT.....	23
FIGURE 9: MODULE TIMING.....	23
FIGURE 10: CONNECTION OF SERIAL INTERFACES.....	24
FIGURE 11: RS-232 LEVEL SHIFT CIRCUIT	24
FIGURE 12: I2C DESIGN FOR L76-L MODULE.....	25
FIGURE 13: PPS VS. NMEA TIMING.....	28
FIGURE 14: REFERENCE DESIGN WITH ACTIVE ANTENNA.....	30
FIGURE 15: REFERENCE DESIGN FOR ACTIVE ANTENNA WITH ANTON.....	31
FIGURE 16: REFERENCE DESIGN WITH PASSIVE ANTENNA.....	32
FIGURE 17: REFERENCE DESIGN FOR PASSIVE ANTENNA WITH LNA.....	33
FIGURE 18: TOP AND SIDE DIMENSIONS (UNIT: MM).....	37
FIGURE 19: BOTTOM DIMENSIONS (UNIT: MM).....	38
FIGURE 20: RECOMMENDED FOOTPRINT (UNIT: MM).....	38
FIGURE 21: TOP VIEW OF THE MODULE	39
FIGURE 22: BOTTOM VIEW OF THE MODULE	39
FIGURE 23: RECOMMENDED REFLOW SOLDERING THERMAL PROFILE.....	40
FIGURE 24: TAPE AND REEL SPECIFICATIONS.....	42

1 Introduction

This document defines and specifies L76 series GNSS module. It describes L76 series GNSS module's hardware interface, external application reference circuits, mechanical size and air interface.

This document can help you quickly understand the interface specifications, as well as electrical and mechanical details of L76 series GNSS module. We also offer you other documents such as L76 series protocol specification and user guider. These documents ensure you can use L76 series module to design and set up mobile applications quickly.

L76 series module contains three variants: L76, L76-L, and L76B. You can choose the dedicated type base on your requirement .The following table shows the entire models of L76 series.

Table 1: L76 Series Products

Module	GPS	GLONASS	BeiDou	Embedded LNA	I2C
L76	✓	✓			
L76-L	✓	✓		✓	✓
L76B	✓		✓		

2 Product Concept

2.1. General Description

L76 series module is a single receiver module integrated with GLONASS/BeiDou and GPS system. It is able to achieve the industry's highest level of sensitivity, accuracy and TTFF with the lowest power consumption in a small-footprint lead-free package. The embedded flash memory provides capacity for storing user-specific configurations and allows for future updates.

The L76 series module supports multiple positioning and navigation system including autonomous GPS, GLONASS, BeiDou, SBAS (including WAAS, EGNOS, MSAS and GAGAN), QZSS, and AGPS.

Embedded with many advanced power saving modes including period, AlwaysLocate[™], standby and backup, L76 series module has excellent low-power consumption in different scenes.

EASY technology as the key feature of L76 series module is one kind of AGPS. Capable of collecting and processing all internal aiding information like GPS time, Ephemeris, Last Position, etc., the GNSS module delivers a very short TTFF in either Hot or Warm start.

L76 series module is an SMD type module with the compact 10.1mm × 9.7mm × 2.5mm form factor. It can be embedded in your applications through the 18-pin pad. It provides necessary hardware interfaces for connection with the main PCB.

The module is fully RoHS compliant to EU regulation.

2.2. Key Features

Table 2: Key Features

Features	Implementation
Receiver Type	<ul style="list-style-type: none"> ● GPS L1 1575.42MHz C/A Code ● GLONASS L1 1598.0625~1605.375 MHz C/A Code (L76&L76-L) ● BeiDou B1 1561.098MHz C/A Code (L76B)
Power Supply	<ul style="list-style-type: none"> ● Supply voltage: 2.8V - 4.3V Typical: 3.3V
Power Consumption	<ul style="list-style-type: none"> ● Refer to Table 11
Sensitivity	<ul style="list-style-type: none"> ● Acquisition: -148dBm@L76 ● Reacquisition: -160dBm@L76 ● Tracking: -165dBm@L76
	<ul style="list-style-type: none"> ● Acquisition: -149dBm @L76-L ● Reacquisition: -161dBm@L76-L ● Tracking: -167dBm@L76-L
	<ul style="list-style-type: none"> ● Acquisition: -148dBm@ L76B ● Reacquisition: -160dBm@ L76B ● Tracking: -163dBm@ L76B
Time-to-First-Fix (EASY Enabled)	<ul style="list-style-type: none"> ● Cold Start: <15s average @-130dBm ● Warm Start: <5s average @-130dBm ● Hot Start: 1s @-130dBm
Time-to-First-Fix (EASY Disabled)	<ul style="list-style-type: none"> ● Cold Start (Autonomous): <35s average @-130dBm ● Warm Start (Autonomous): <30s average @-130dBm ● Hot Start (Autonomous): 1s @-130dBm
Horizontal Position Accuracy (Autonomous)	<ul style="list-style-type: none"> ● <2.5 m CEP @-130dBm
Update Rate	<ul style="list-style-type: none"> ● Up to 10Hz, 1Hz by default
Accuracy of 1PPS Signal	<ul style="list-style-type: none"> ● Typical accuracy <10ns ● Time pulse width 100ms
Velocity Accuracy	<ul style="list-style-type: none"> ● Without aid: 0.1m/s
Acceleration Accuracy	<ul style="list-style-type: none"> ● Without aid: 0.1m/s²
Dynamic Performance	<ul style="list-style-type: none"> ● Maximum Altitude: 18,000m
	<ul style="list-style-type: none"> ● Maximum Velocity: 515m/s
	<ul style="list-style-type: none"> ● Acceleration: 4G
UART Port	<ul style="list-style-type: none"> ● UART port: TXD1 and RXD1
	<ul style="list-style-type: none"> ● Supports baud rate from 4800bps to 115200bps; 9600bps by default
	<ul style="list-style-type: none"> ● UART Port is used for NMEA output, PMTK/PQ commands input

	and firmware upgrade
I2C	<ul style="list-style-type: none"> ● Supports fast mode, with bit rate up to 400kbps ● Supports 7-bit address ● Outputs NMEA data by default when reading; it can also receive PMTK/PQ commands by I2C bus.
Temperature Range	<ul style="list-style-type: none"> ● Normal operation: -45°C ~ +85°C ● Storage temperature: -45°C ~ +125°C
Physical Characteristics	<ul style="list-style-type: none"> ● Size: 10.1±0.15 × 9.7±0.15 × 2.5±0.15mm ● Weight: Approx. 0.6g

2.3. Block Diagram

The following figure shows the block diagram of L76 series module. It consists of a single chip GNSS IC which includes the RF part and Baseband part, a LNA, a SAW filter, a TCXO and a crystal oscillator.

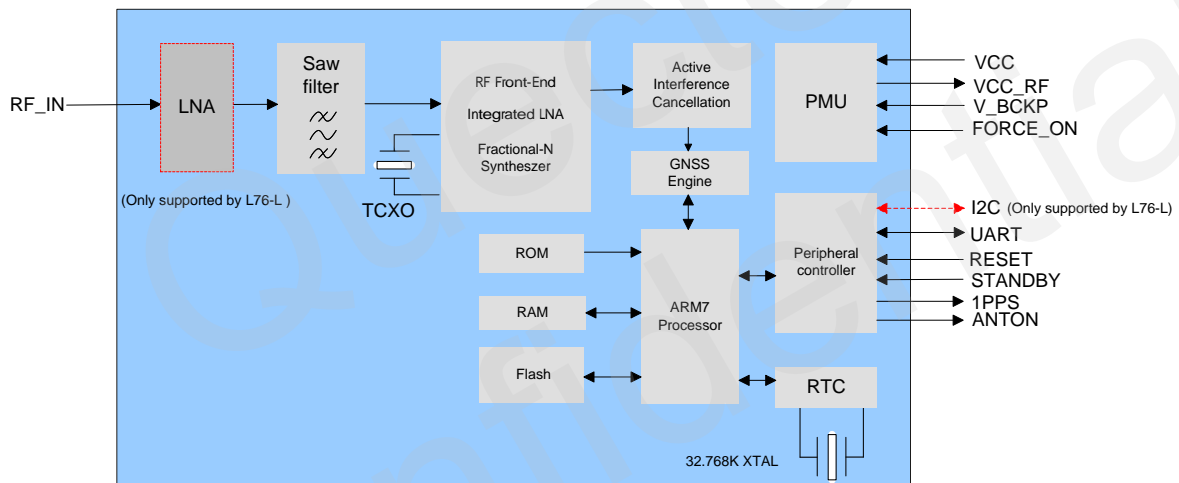

Figure 1: Block Diagram

2.4. Evaluation Board

In order to help you use L76 series GNSS module on your applications, Quectel supplies an Evaluation Board (EVB) with Micro-USB cable, active antenna and other peripherals to test the module. For more details, please refer to the **document [1]**.

2.5. Protocols Supported by the Module

Table 3: Protocols Supported by the Module

Protocol	Type
NMEA	Input/Output, ASCII, 0183, 3.01
PMTK	Input/Output, MTK proprietary protocol
PQ	Input/Output, Quectel proprietary protocol

NOTE

1. Please refer to **document [2]** for details of NMEA standard protocol and MTK proprietary protocol.
2. Please refer to **document [6]** for details of Quectel proprietary protocol.

Quectel
Confidential

3 Application

The module is equipped with an 18-pin 1.1mm pitch SMT pad that connects to your application platform. Sub-interfaces included in the pad are described in details in the following chapters.

3.1. Pin Assignment



Figure 2: Pin Assignment

3.2. Pin Definition

Table 4: Pin Description

Power Supply					
Pin Name	Pin No.	I/O	Description	DC Characteristics	Comment
VCC	8	I	Main power supply	Vmax=4.3V Vmin=2.8V Vnom=3.3V	Assure load current not less than 150mA.

V_BCKP	6	I	Backup power supply	Vmax=4.5V Vmin=1.5V Vnom=3.3V I _{V_BCKP} =7uA @Backup mode	Supply power for RTC domain when VCC is powered off.
VCC_RF	14	O	Supply power for external RF component	Vmax=4.3V Vmin=2.8V Vnom=3.3V	Usually supply power for external active antenna or LNA. If unused, keep this pin open. VCC_RF≈ VCC

Reset

Pin Name	Pin No.	I/O	Description	DC Characteristics	Comment
RESET	9	I	System reset	VILmin=-0.3V VILmax=0.7V VIHmin=2.1V VIHmax= 3.1V	It is low level active. If unused, keep this pin open or connect it to VCC.

UART Port

Pin Name	Pin No.	I/O	Description	DC Characteristics	Comment
RXD1	3	I	Receive data	VILmin=-0.3V VILmax=0.7V VIHmin=2.1V VIHmax= 3.1V	UART Port is used for NMEA output, PMTK/PQ commands input and firmware upgrade.
TXD1	2	O	Transmit data	VOLmax=0.42V VOHmin=2.4V VOHnom=2.8V	

RF Interface

Pin Name	Pin No.	I/O	Description	DC Characteristics	Comment
RF_IN	11	I	RF signal input	Characteristic impedance of 50Ω	Refer to chapter 4

Other Interfaces

Pin Name	Pin No.	I/O	Description	DC Characteristics	Comment
ANTON	13	O	External LNA control pin and active antenna power control pin in power save mode	VOLmax=0.42V VOHmin=2.4V VOHnom=2.8V	If unused, keep this pin open.
STANDBY	5	I	Used to enter into or exit from	VILmin=-0.3V VILmax=0.7V	It is pulled up internally. It is edge-triggered.

			standby mode	VIHmin=2.1V VIHmax=3.1V	If unused, keep this pin open.
1PPS	4	O	One pulse per second	VOLmax=0.42V VOHmin=2.4V VOHnom=2.8V	Synchronized at rising edge, the pulse width is 100ms. If unused, keep this pin open.
FORCE_ON	18	I	Logic high will force module to be woken up from backup mode	VILmin=-0.3V VILmax=0.7V VIHmin=2.1V VIHmax=3.1V	Keep this pin open or pulled low before entering into backup mode. It belongs to RTC domain. If unused, keep this pin open.
RESERVED /I2C_SDA	16	I/O	For L76/L76B, Keep it open. For L76-L, this pin is I2C_SDA.	VILmin=-0.3V VILmax=0.7V VIHmin=2.1V VIHmax=3.1V	For L76-L, I2C Interface outputs NMEA data by default when reading; it can also receive PMTK/PQ commands by I2C bus.
RESERVED /I2C_SCL	17	I/O	For L76/L76B, Keep it open. For L76-L, this pin is I2C_SCL.	VOLmax=0.42V VOHmin=2.4V VOHnom=2.8V	

3.3. Power Supply

VCC pin supplies power for BB, RF, I/O and RTC domain. The load current of VCC pin varies according to the VCC level, processor load and satellite acquisition. Typical VCC peak current is 40mA during GPS acquisition after power up. So it is important to supply sufficient current and make the power clean and stable. Meanwhile, you should choose the LDO without built-in output high-speed discharge function to keep long output voltage drop-down period. The decouple combination of 10uF and 100nF capacitor is recommended nearby VCC pin.

The V_BCKP pin supplies power for RTC domain. A cell battery with the combination of 4.7uF and 100nF capacitor is recommended nearby V_BCKP pin. The voltage of RTC domain ranges from 1.5V to 4.5V. In order to achieve better Time to First Fix (TTFF), RTC domain should be valid all the time. It can supply power for SRAM memory in RTC domain which contains all the necessary GPS information for quick start-up and a small amount of user configuration variables.

The module's internal power construction is shown as below.

VCC pin supplies power for not only PMU but also VCC_RF and RTC domain. V_BCKP supplies power for RTC domain only. The two diodes in the following figure construct an OR gate to supply power for RTC domain. FORCE_ON pin belongs to RTC domain. The signal which has been shown as red line in the following diagram can open and close the switch. The following actions will close or open the switch:

- The switch will be closed by default when VCC is supplying power (VCC off → on).
- Based on the above step, FORCE_ON open or low and sending PMTK command can open the switch (full on → backup).
- Based on the above step, FORCE_ON logic high can close the switch (backup → full on).

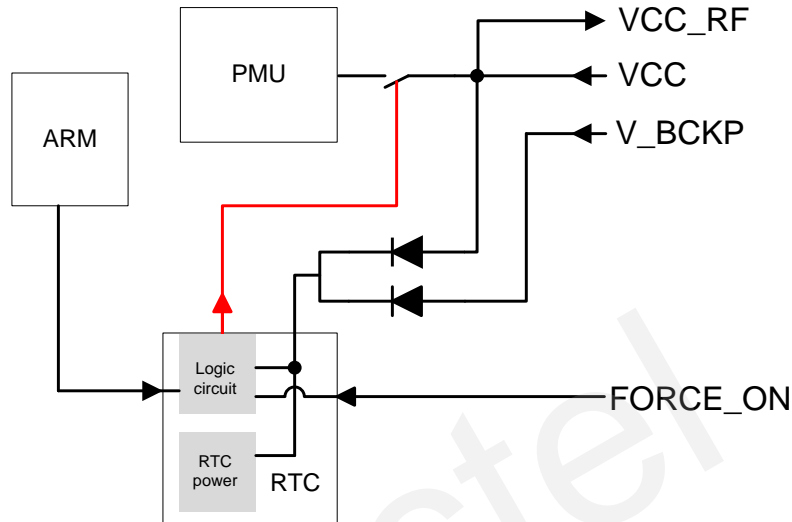

Figure 3: Internal Power Construction

3.4. Operation Modes

The table below briefly illustrates the relationship among different operation modes of L76 series module.

Table 5: Module State Switch

Current Mode	Next Mode			Period	AlwaysLocate
	Backup	Standby	Full on		
Backup	N/A	N/A	Refer to chapter 3.4.3	N/A	N/A
Standby	N/A	N/A	Pull STANDBY high Send any data via UART1	N/A	N/A
Full on	Refer to chapter 3.4.3	Pull STANDBY low PMTK161	N/A	PMTK 225	PMTK225
Period	N/A	N/A	Refer to chapter 3.4.4	N/A	N/A

Always Locate	N/A	N/A	Refer to chapter 3.4.5	N/A	N/A
---------------	-----	-----	-------------------------------	-----	-----

NOTE

Please refer to **document [2]** for more details of MTK proprietary protocol.

3.4.1. Full on Mode

Full on mode includes tracking mode and acquisition mode. Acquisition mode is defined as the module starts to search satellites, determine visible satellites and coarse carrier frequency as well as code phase of satellite signals. When the acquisition is completed, it switches to tracking mode automatically. Tracking mode is defined as the module tracks satellites and demodulates the navigation data from the specific satellites.

Whether the combination of VCC and V_BCKP pins is valid or VCC is valid, the module will enter into full on mode automatically and follow the default configuration as below. You can refer to **chapter 3.3** about internal power construction to have a good comprehension. You also can use PMTK commands to change the configuration to satisfy requirements.

Table 6: Default Configuration

Item	Configuration	Comment
Baud Rate	9600bps	
Protocol	NMEA	RMC, VTG, GGA, GSA, GSV and GLL
Update Rate	1Hz	
SBAS	Enable	
AIC	Enable	
LOCUS	Disable	
Easy Technology	Enable	EASY will be disabled automatically when update rate exceeds 1Hz.
GNSS	GPS+GLONASS@L76&L76-L GPS+BeiDou@L76B	

In full on mode, the consumption will comply with the following regulation:

When the module is powered on, the average current will rush to 40mA and last for a few seconds; then

the consumption will be decreased to the acquisition current marked in **table 1** and we defined this state as acquisition state, and also it will last for several minutes until it switches to tracking state automatically. The consumption in tracking state is less than acquisition. The value is also listed in **table 1**.

Using PMTK commands can switch among multiple positioning systems:

For L76/L76L

- \$PMTK353,0,1*36: search GLONASS satellites only
- \$PMTK353,1,0*36: search GPS satellites only
- \$PMTK353,1,1*37: search GLONASS and GPS satellites

For L76B

- \$PMTK353,0,0,0,0,1*2A: search BDS satellites only
- \$PMTK353,1,0,0,0,0*2A: search GPS satellites only
- \$PMTK353,1,0,0,0,1*2B: search GPS and BDS satellites

3.4.2. Standby Mode

Standby mode is a low-power consumption mode. In standby mode, the internal core and I/O power domain are still active, but RF and TCXO are powered off, and the module stops satellites search and navigation. UART1 is still accessible through PMTK commands or any other data, but there is no NMEA messages output.

There are two ways to enter into standby mode and exit from standby mode.

- **Using STANDBY pin:** Pulling STANDBY low will make the GNSS module enter into standby mode and releasing STANDBY which has been pulled high internally will make the module back to full on mode. Note that pulling down STANDBY pin to ground will cause the extra current consumption which makes the typical standby current reach to about 600uA @ VCC=3.3V.
- **Using PMTK command:** Sending PMTK command "\$PMTK161,0*28" will enter into standby mode. Sending any data via UART1 will make the module exit from standby mode as UART1 is still accessible in standby mode. When the module exit from standby mode, it will use all internal aiding information like GPS time, Ephemeris, Last Position, etc., resulting to the fastest possible TTFF in either Hot or Warm start. The typical current consumption in this way is about 500uA @VCC=3.3V in standby mode.

NOTE

Setting the customer's GPIO which controls STANDBY pin as input is recommended before turning on the module to avoid entering into standby mode unexpectedly during starting the module due to its edge-triggered characteristic. After that, customer can reset the GPIO as output to control the STANDBY pin. If it is unused, keep it open.

3.4.3. Backup Mode

Backup mode requires lower power consumption than standby mode. In this mode, the module stops to acquire and track satellites. UART1 is not accessible. But the backed-up memory in RTC domain which contains all the necessary GPS information for quick start-up and a small amount of user configuration variables is alive. Due to the backed-up memory, EASY technology is available. The current consumption in this mode is about 7uA.

There are two ways to enter into backup mode and back to full on mode.

- Send command "\$PMTK225,4*2F" (the red line opens the switch in Figure 3) to enter into backup mode forever. The only way to wake up the module is pulling the FORCE_ON high (the red line closes the switch in Figure 3).
- Cutting off VCC and keeping V_BCKP powered will make the module enter into backup mode from full on mode. As long as the VCC pin is powered, the module will enter into full on mode immediately.

NOTE

Keep FORCE_ON pin open or low before entering into backup mode. Or else, the backup mode will be unavailable.

To have a good comprehension, please refer to **chapter 3.3** to see details about the internal power construction. The V_BCKP pin can be directly provided by an external capacitor or battery (rechargeable or non-chargeable). Please refer to the following figure for RTC backup reference design.

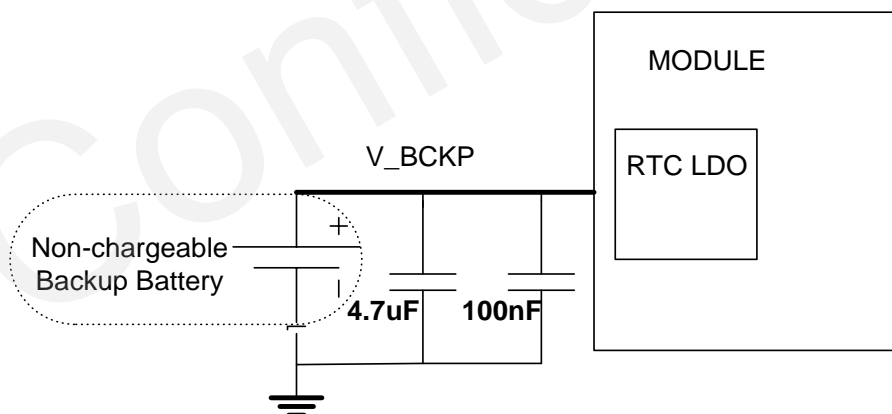

Figure 4: RTC Supply from Non-chargeable Battery

The V_BCKP pin does not support charging function for rechargeable battery. It is necessary to add a charging circuit for rechargeable batteries.

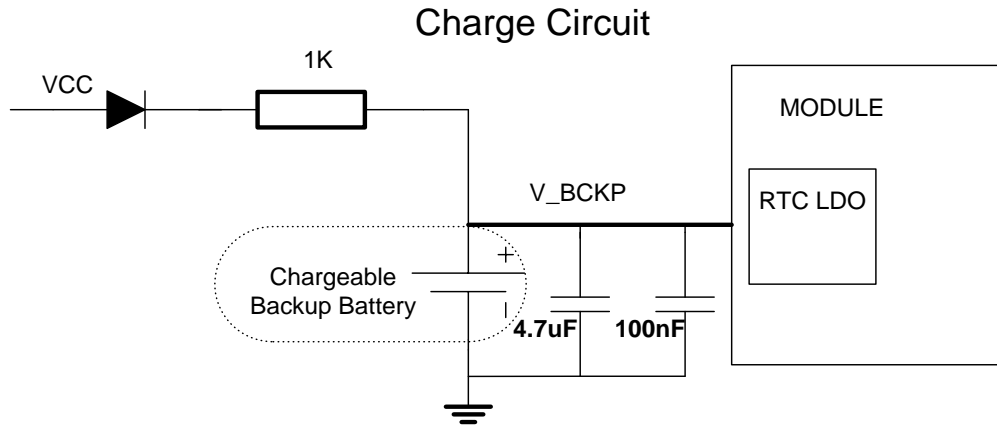

Figure 5: Reference Charging Circuit for Rechargeable Batteries

Coin-type Rechargeable Capacitor from Seiko (<http://www.sii.co.jp/en/>) can be used and Schottky diode from ON Semiconductor (<http://www.onsemi.com/>) is recommended to be used here for its low voltage drop.

3.4.4. Periodic Mode

Periodic mode is a mode that can control the full on mode and standby/backup mode periodically to reduce power consumption. It contains Periodic standby mode and Periodic backup mode.

The format of the command which enables the module to enter into periodic mode is as following:

Table 7: PMTK Command Format

Format:		
\$PMTK225,<Type>,<Run_time>,<Sleep_time>,<2nd_run_time>,<2nd_sleep_time>*<checksum> <CR><LF>		
Parameter	Format	Description
Type	Decimal	Type=1 for Periodic Backup Mode Type=2 for Periodic Standby Mode
Run_time	Decimal	Run_time =Full on mode period (ms)
Sleep_time	Decimal	Sleep_time =Standby/Backup mode period (ms)
2nd_run_time	Decimal	2nd_run_time =Full on mode period (ms) for extended acquisition in case module's acquisition fails during the Run_time
2nd_sleep_time	Decimal	2nd_sleep_time =Standby/Backup mode period (ms) for extended sleep in case module's acquisition fails during

the **Run_time**

Checksum	Hexadecimal	Hexadecimal checksum
-----------------	-------------	----------------------

Example

```
$PMTK225,2,3000,12000,18000,72000*15<CR><LF>
$PMTK225,1,3000,12000,18000,72000*16<CR><LF>
```

Sending “\$PMTK225,0*2B” in any time will make the module enter into full on mode from Periodic standby mode.

Pulling the FORCE_ON high and sending “\$PMTK225,0*2B” immediately will make the module enter into full on mode from Periodic backup mode.

Sending “\$PMTK225,0*2B” in **Run_time** or **2nd_run_time** will also make the module enter into full on mode from Periodic backup mode, but it is hard to operate and not recommended.

NOTES

1. Setting the customer’s GPIO which controls STANDBY pin as input is recommended before turning on the module to avoid entering into standby mode unexpectedly during starting the module due to its edge-triggered characteristic. After that, customer can reset the GPIO as output to control the STANDBY pin. If it is unused, keep it open.
2. Keep FORCE_ON pin open or low before entering into periodic backup mode. Or else, the periodic backup mode will be unavailable.

The following figure has shown the operation of periodic mode. When you send PMTK command, the module will be in the full on mode firstly. After several minutes, the module will enter into the periodic mode and follow the parameters set by you. When the module fails to fix the position in **run time**, the module will switch to second run and sleep time automatically. As long as the module fixes the position again, the module will return to first run and sleep time.

Note that before entering into periodic mode, assure the module is in the tracking mode; otherwise the module will have a risk of failure to track the satellite. If GNSS module is located in weak signal environment, it is better to set a longer second run time to ensure the success of reacquisition.

The average current value can be calculated by the following formula:

$$I_{\text{periodic}} = (I_{\text{tracking}} * T1 + I_{\text{standby/backup}} * T2) / (T1 + T2) \quad T1: \text{Run time}, T2: \text{Sleep time}$$

Example

PMTK225,2,3000,12000,18000,72000*15 for periodic mode with 3s in tracking mode and 12s in standby mode based on GPS&GLONASS. The average current consumption is calculated below:

$$I_{\text{periodic}} = (I_{\text{tracking}} * T1 + I_{\text{standby}} * T2) / (T1 + T2) = (22\text{mA} * 3\text{s} + 0.5\text{mA} * 12\text{s}) / (3\text{s} + 12\text{s}) \approx 4.8(\text{mA})$$

PMTK225,1,3000,12000,18000,72000*16 for periodic mode with 3s in tracking mode and 12s in backup mode based on GPS&GLONASS. The average current consumption is calculated below:

$$I_{\text{periodic}} = (I_{\text{tracking}} * T1 + I_{\text{backup}} * T2) / (T1 + T2) = (22\text{mA} * 3\text{s} + 0.007\text{mA} * 12\text{s}) / (3\text{s} + 12\text{s}) \approx 4.4(\text{mA})$$

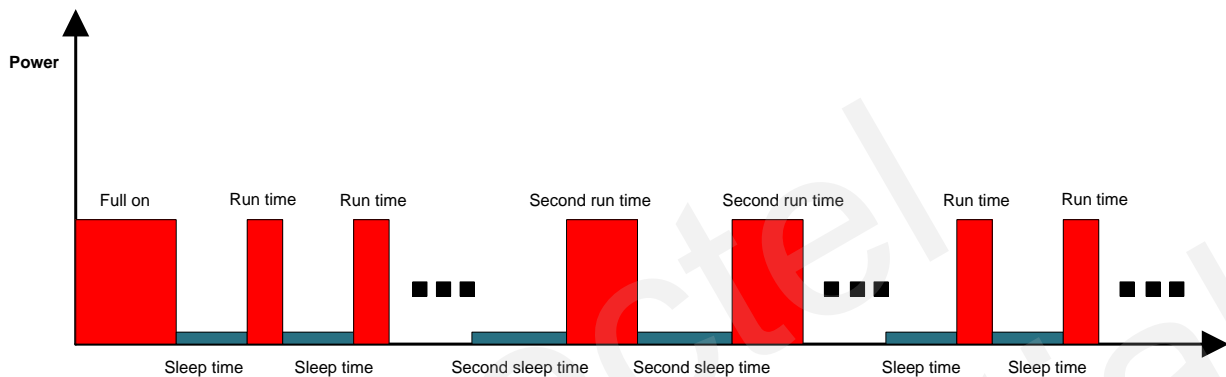

Figure 6: Periodic Mode

3.4.5. AlwaysLocate™ Mode

AlwaysLocate™ is an intelligent power saving mode. It contains AlwaysLocate™ backup mode and AlwaysLocate™ standby mode.

AlwaysLocate™ standby mode allows the module to switch automatically between full on mode and standby mode. According to the environmental and motion conditions, the module can adaptively adjust the full on time and standby time to achieve the balance between positioning accuracy and power consumption. Sending "\$PMTK225,8*23" and the module returning "\$PMTK001,225,3*35" means the module accesses AlwaysLocate™ standby mode successfully. It will benefit power saving in this mode. Sending "\$PMTK225,0*2B" in any time will make the module back to full on mode.

AlwaysLocate™ backup mode is similar to AlwaysLocate™ standby mode. The difference is that AlwaysLocate™ backup mode switches automatically between full on mode and backup mode. The PMTK command to enter into AlwaysLocate™ backup mode is "\$PMTK225,9*22". Pulling FORCE_ON high and sending "\$PMTK225,0*2B" immediately will make the module enter into full on mode.

The position accuracy in AlwaysLocate™ mode will be degraded, especially in high speed. The following picture shows the rough consumption in different scenes.

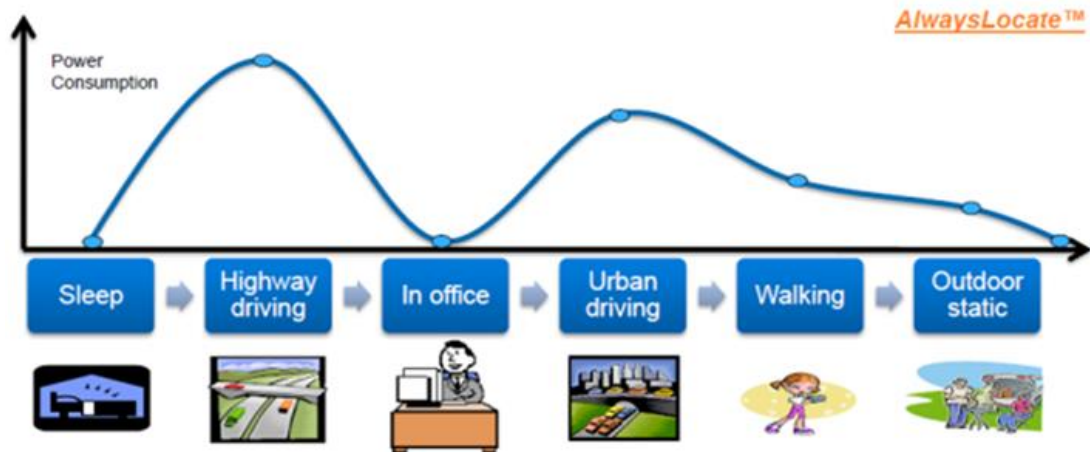

Figure 7: AlwaysLocate™ Mode

Example

The average consumption of the module which is located in outdoors in static and equipped active antenna after tracking satellites is about 2.7mA in AlwaysLocate™ standby mode based on GPS&GLONASS.

The average consumption of the module which is located in outdoors in static and equipped active antenna after tracking satellites is about 2.6mA in AlwaysLocate™ backup mode based on GPS&GLONASS.

NOTES

1. Setting the customer's GPIO which controls STANDBY pin as input is recommended before turning on the module to avoid entering into standby mode unexpectedly during starting the module due to its edge-triggered characteristic. After that, customer can reset the GPIO as output to control the STANDBY pin. If it is unused, keep it open.
2. Keep FORCE_ON pin open or low before entering into AlwaysLocate™ backup mode. Or else, the AlwaysLocate™ backup mode will be unavailable.

3.5. Reset

L76 series module can be restarted by driving the RESET to a low level voltage for a certain time and then releasing it. This action will force volatile RAM data loss. Note that Non-Volatile Backup RAM content is not cleared and thus fast TTFB is possible. An OC driver circuit shown as below is recommended to control the RESET.

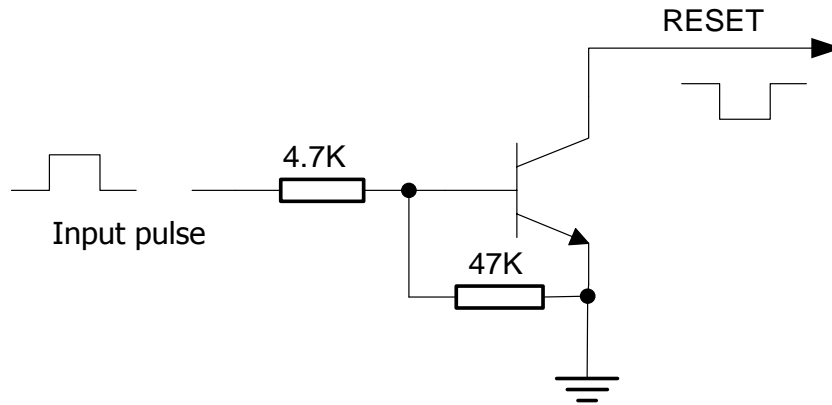

Figure 8: Reference Reset Circuit using OC Circuit

The following picture shows the timing of L76 series module.

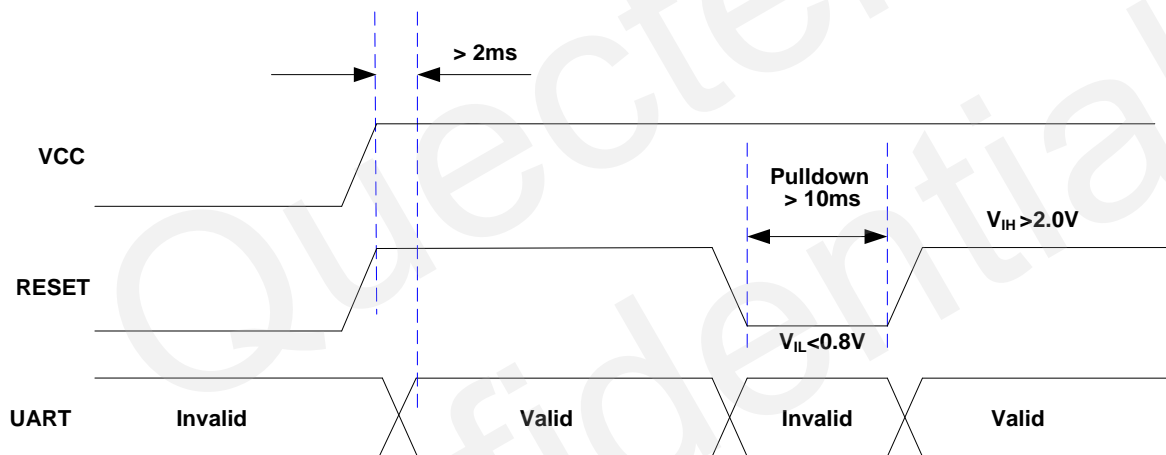

Figure 9: Module Timing

3.6. UART Interface

The module provides one universal asynchronous receiver & transmitter serial port. The module is designed as DCE (Data Communication Equipment), following the traditional DCE-DTE (Data Terminal Equipment) connection. The module and the client (DTE) are connected through the signal shown in the following figure. It supports data baud-rate from 4800bps to 115200bps.

UART port:

- TXD1: Send data to the RXD signal line of DTE
- RXD1: Receive data from the TXD signal line of DTE

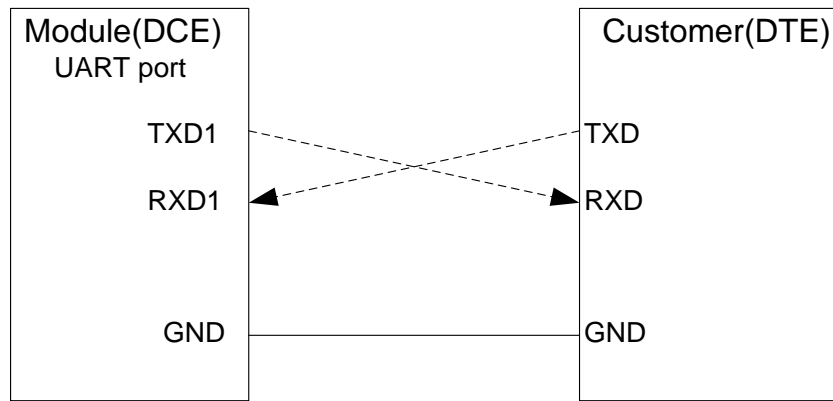

Figure 10: Connection of Serial Interfaces

This UART port has the following features:

- UART port can be used for firmware upgrade, NMEA output and PMTK proprietary messages input.
- The default output NMEA type setting is RMC, VTG, GGA, GSA, GSV and GLL.
- UART port supports the following data rates:
4800, 9600, 14400, 19200, 38400, 57600, 115200bps.
The default setting is 9600bps, 8 bits, no parity bit, 1 stop bit.
- Hardware flow control and synchronous operation are not supported.

The UART port does not support the RS-232 level but only CMOS level. If the module's UART port is connected to the UART port of a computer, it is necessary to add a level shift circuit between the module and the computer. Please refer to the following figure.

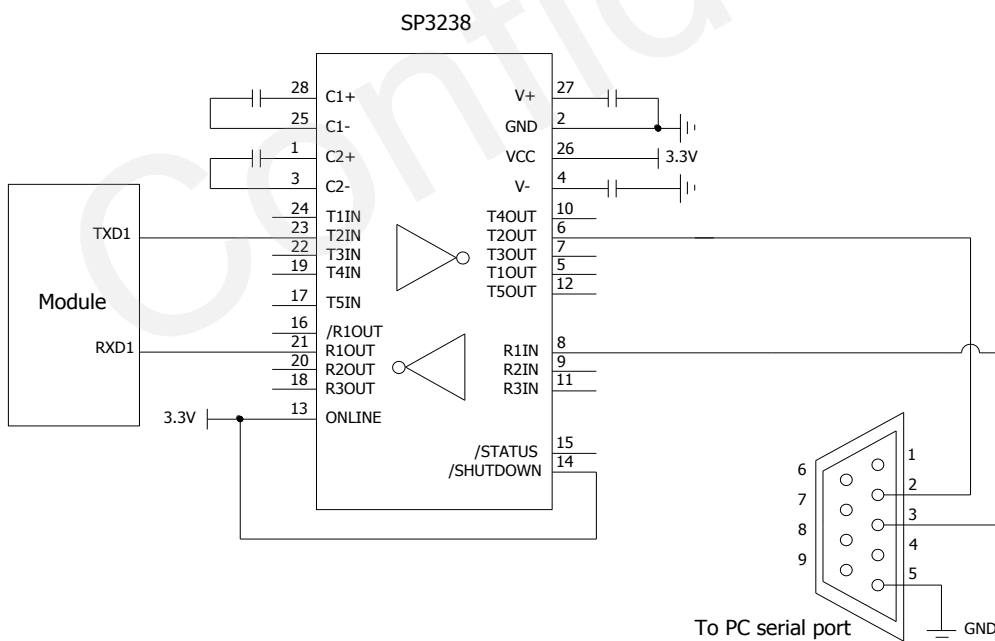

Figure 11: RS-232 Level Shift Circuit

NOTE

As GNSS module outputs more data than a single GPS system. The default output NMEA types running in 4800bps baud rate and 1Hz update rate will lose some data. The solution to avoid losing data in 4800bps baud rate and 1Hz update rate is to decrease the output NMEA types. 9600bps baud rate is enough to transmit GNSS NMEA in default settings and it is thus recommended.

3.7. I2C Interface

L76-L module provides a set of I2C interface. The interface outputs NMEA data by default when reading. It can also receive PMTK/PQ commands by I2C bus.

The I2C interface has the following features:

- Support fast mode, with bit rate up to 400kbps.
- Support 7-bit address.
- Work on slave mode.
- Default I2C address values are Write: 0x20, Read: 0x21.

For more details, please refer to the **document [5]**.

The following circuit is an example of connection.

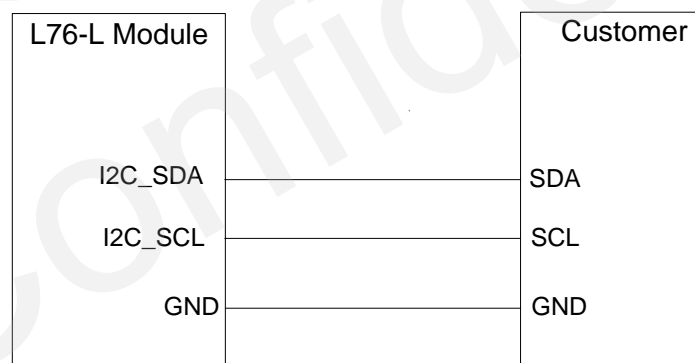

Figure 12: I2C Design for L76-L Module

NOTES

1. I2C_SDA/I2C_SCL is pulled up to 2.8V inside L76-L module. There is no need to add a pull-up resistor externally.
2. The voltage threshold of I2C is 2.8V. If the system voltage is not consistent with it, a level shifter circuit must be used.

3.8. EASY Technology

Supplying aided information like ephemeris, almanac, rough last position, time, and satellite status, can help improving GNSS module TTFF and the acquisition sensitivity. We call this as EASY technology and L76 series GNSS module supports it.

EASY technology works as embedded software which can accelerate TTFF by predicting satellite navigation messages from received ephemeris. The GNSS engine will calculate and predict orbit information automatically up to 3 days after first receiving the broadcast ephemeris, and save the predicted information into the internal memory. GNSS engine will use the information for positioning if no enough information from satellites, so the function is helpful for positioning and TTFF improvement.

The EASY function can reduce TTFF to 5s in warm start. In this case, RTC domain should be valid. In order to gain enough broadcast ephemeris information from GNSS satellites, the GNSS module should receive the information for at least 5 minutes in good signal conditions after it fixes the position.

EASY function is enabled by default. Command “\$PMTK869,1,0*34” can be used to disable EASY function. For more details, please refer to the **document [2]**.

3.9. EPO Data Service

L76 series module features a function called EPO (Extended Prediction Orbit) which is a world leading technology that supports 30-day orbit predictions to customers. Occasional download from the EPO server is needed. For more details, please refer to the **document [4]**.

3.10. Multi-tone AIC

L76 series module has a function called multi-tone AIC (Active Interference Cancellation) to decrease harmonic of RF noise from Wi-Fi, Bluetooth, GSM and 3G.

Up to 12 multi-tone AIC embedded in the module can provide effective narrow-band interference and jamming elimination. The GNSS signal could be demodulated from the jammed signal, which can ensure better navigation quality. AIC function is enabled by default. Enabling AIC function will increase about 1mA @VCC=3.3V consumption. The following commands can be used to set AIC function.

Enable AIC function: “\$PMTK 286,1*23”.

Disable AIC function: “\$PMTK 286,0*22”.

3.11. ANTON

L76 series module provides a pin called ANTON which is related to module state. Its voltage level will change in different module states. When the module works in full on mode, this pin is in high level. While working in standby mode, backup mode, AlwaysLocate™ mode, and during sleep time in periodic mode, this pin is in low level. Based on this characteristic, the ANTON pin can be used to control the power supply of active antenna or the enable pin of the external LNA to reduce power consumption.. Please refer to **chapter 3.2** for more electrical characteristics about this pin. There is an example of this pin's application described in **chapter 4.2**.

3.12. LOCUS

The L76 series module supports the embedded logger function called LOCUS. It can log position information to internal flash memory automatically when this function is enabled by sending PMTK command "\$PMTK185, 0*22". Due to this function, the host can go to sleep to save power consumption and does not need to receive the NMEA information all the time. The module can provide a log capacity of more than 16 hours.

The detail procedures of this function are illustrated below:

- The module has fixed the position (only 3D_fixed is available),
- Sending PMTK command "\$PMTK184,1*22" to erase internal flash.
- Sending PMTK command "\$PMTK185,0*22" to start logging.
- Module logs the basic information (UTC time, latitude, longitude and height) every 15 seconds to internal flash memory.
- Stop logging the information by sending "\$PMTK185,1*23".
- MCU can get the data via UART1 by sending "\$PMTK622,1*29" to the module.

The raw data which MCU gets has to be parsed via LOCUS parser code provided by Quectel. For more details, please contact Quectel technical supports.

3.13. PPS VS. NMEA

Pulse per Second (PPS) VS. NMEA can be used for time service. The latency range of the beginning of UART Tx is between 465ms and 485ms, and after the rising edge of PPS.

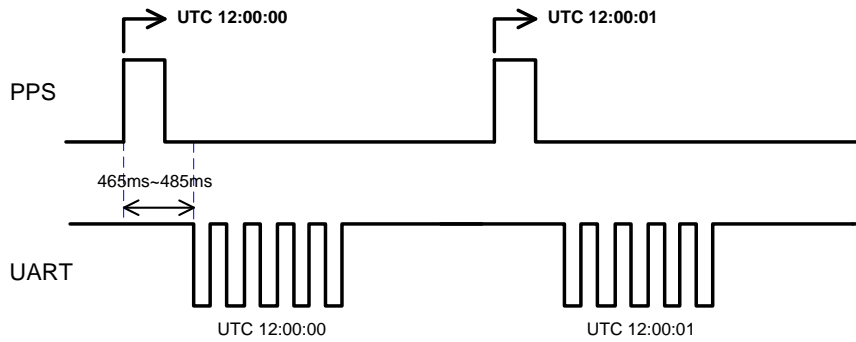

Figure 13: PPS VS. NMEA Timing

The feature only supports 1Hz NMEA output and baud rate at 14400~115200bps. When the baud rate is 9600 or 4800bps, it only supports RMC NMEA sentence output. Because at low baud rates, per second transmission may exceed one second if there are many NMEA sentences output. You can enable this function by sending "\$PMTK255,1*2D", and disable the function by sending "\$PMTK255,0*2C".

Quectel
Confidential

4 Antenna Interfaces

L76 series module supports both GPS and GLONASS/BeiDou systems. The RF signal is obtained from the RF_IN pin. The impedance of RF trace should be controlled as 50 Ohm, and the trace length should be kept as short as possible.

4.1. Antenna Specifications

The L76 series module can be connected to a dedicated GPS/GLONASS/BeiDou passive or active antenna to receive GPS/GLONASS/BeiDou satellite signals. The recommended antenna specifications are given in the following table.

Table 8: Recommended Antenna Specifications

Antenna Type	Specification
Passive Antenna	GPS frequency: 1575.42±2MHz GLONASS frequency: 1602±4MHz BeiDou frequency:1561.098±2MHz VSWR: <2 (Typ.) Polarization: RHCP or Linear Gain: >0dBi
Active Antenna	GPS frequency: 1575.42±2MHz GLONASS frequency:1602±4MHz BeiDou frequency:1561.098±2MHz VSWR: <2 (Typ.) Polarization: RHCP or Linear Noise figure: <1.5dB Gain (antenna): >-2dBi Gain (embedded LNA): 20dB (Typ.) Total gain: >18dBi (Typ.)

4.2. Recommended Circuit for Antenna

Both active and passive antennas can be used for L76 series module.

4.2.1. Active Antenna

4.2.1.1. Active Antenna without ANTON

The following figure is a typical reference design with active antenna. In this mode, the antenna's power is from the VCC_RF.

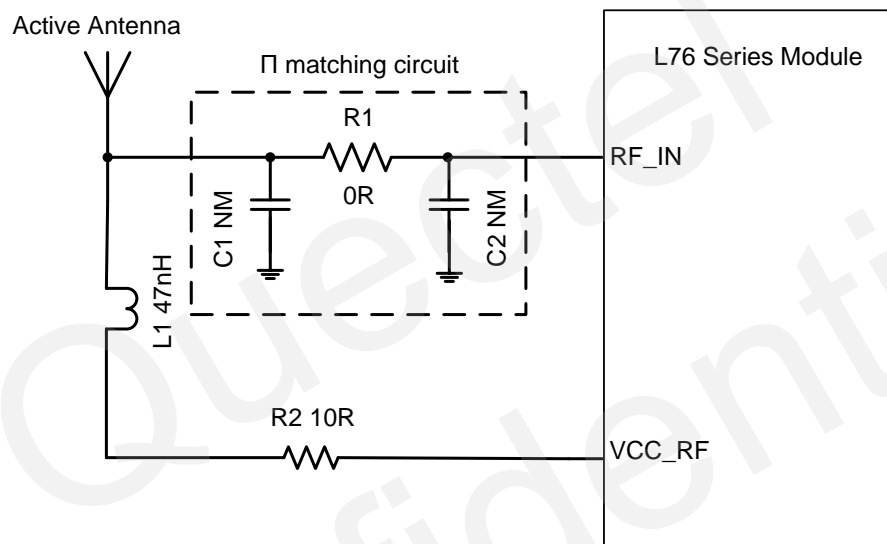

Figure 14: Reference Design with Active Antenna

C1, R1, C2 are reserved matching circuits for antenna impedance modification. By default, C1 and C2 are not mounted, and R1 is 0 ohm.

L76 series module provides power supply for external active antenna by VCC_RF. The voltage ranges from 2.8V to 4.3V, and the typical value is 3.3V. If the VCC_RF voltage does not meet the requirements for powering the active antenna, an external LDO should be used.

The inductor L1 is used to prevent the RF signal from leaking into the VCC_RF pin and route the bias supply to the active antenna; and the recommended value of L1 is no less than 47nH. R2 can protect the whole circuit in case the active antenna is shorted to ground.

4.2.1.2. Active Antenna with ANTON

L76 series module can also reduce power consumption by controlling the power supply of active antenna through the pin “ANTON”.

The reference circuit for active antenna with “ANTON” function is given as below.

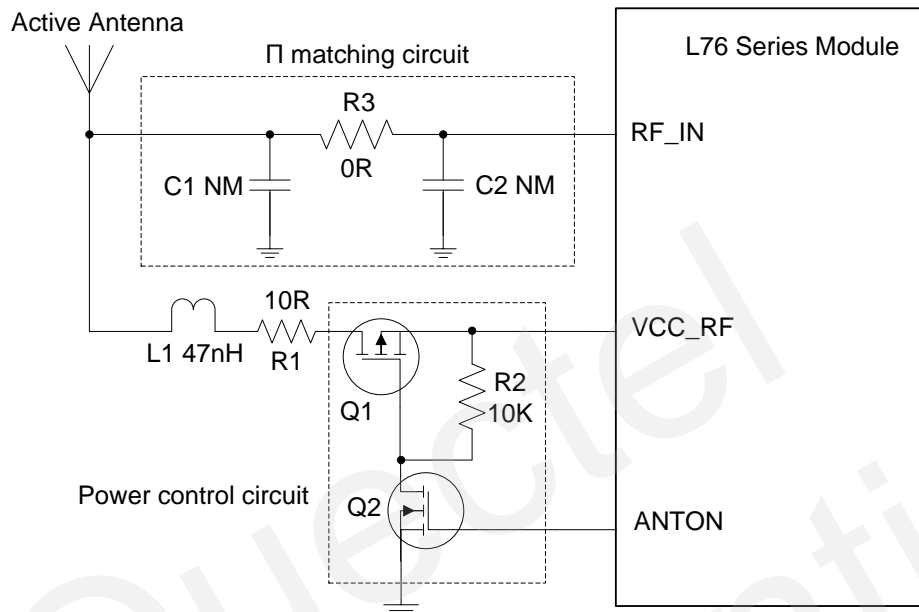

Figure 15: Reference Design for Active Antenna with ANTON

ANTON is an optional pin which can be used to control the power supply of the active antenna. When the ANTON pin is pulled down, MOSFET Q1 and Q2 are in high impedance state and the power supply for antenna is cut off. When ANTON is pulled high, it will make Q1 and Q2 in the on-state, and VCC_RF will provide power supply for the active antenna. The high and low level of ANTON pin is determined by the module’s state. Please refer to **chapter 3.9** for more details. If unused, please keep ANTON pin open.

For minimizing the current consumption, the value of resistor R2 should not be too small, and the recommended value is 10k ohm.

4.2.2. Passive Antenna

4.2.2.1. Passive Antenna without External LNA

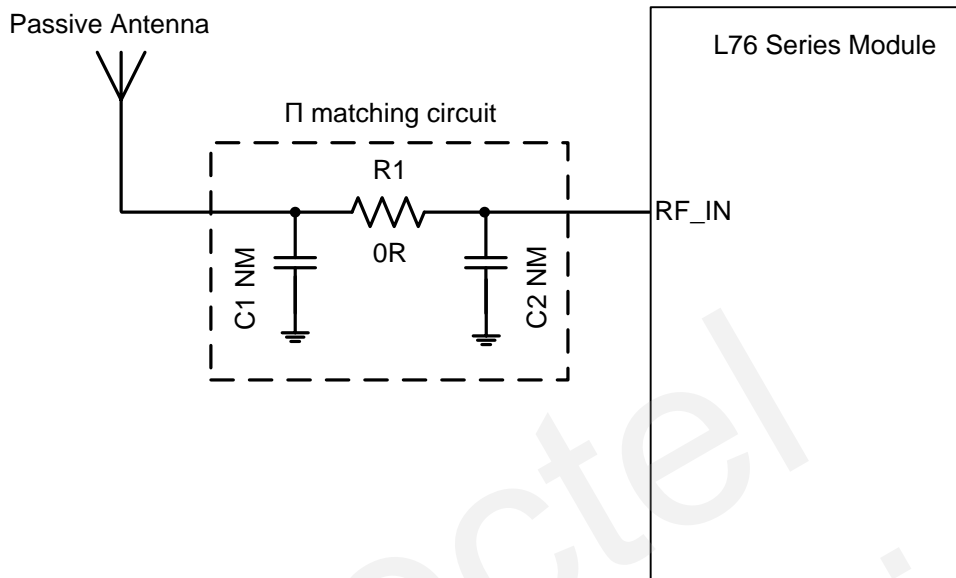

Figure 16: Reference Design with Passive Antenna

The above figure is a typical reference design with passive antenna.

C1, R1, C2 are reserved matching circuits for antenna impedance modification. C1 and C2 are not mounted by default, and R1 is 0 ohm. Impedance of RF trace should be controlled as 50 ohm and the trace length should be kept as short as possible.

4.2.2.2. Passive Antenna with External LNA

In order to improve the receiver sensitivity and reduce the TTFF, an external LNA between the passive antenna and the L76 series module is recommended. The reference design is shown as below.

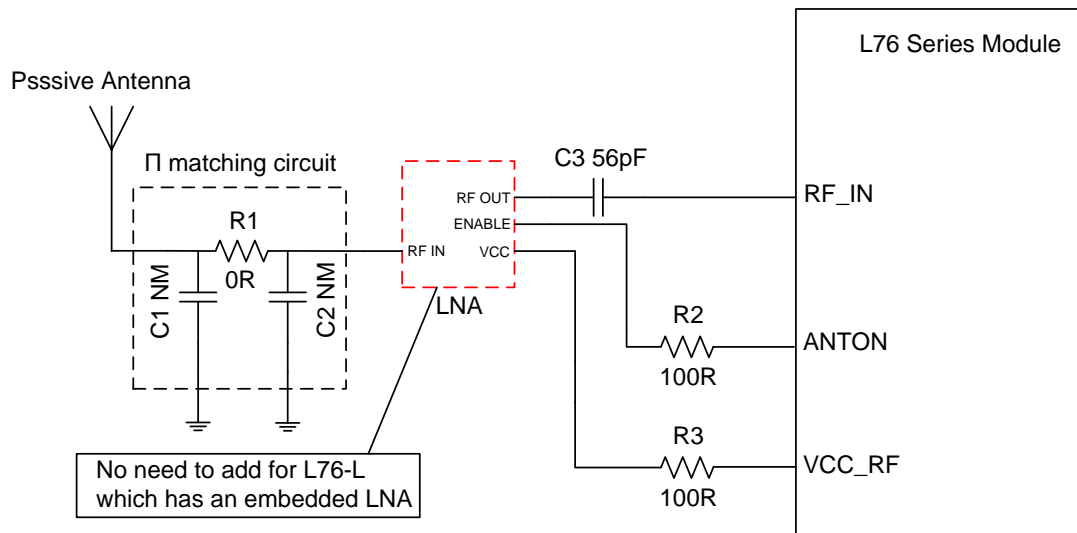

Figure 17: Reference Design for Passive Antenna with LNA

Here, C1, R1, C2 form a reserved matching circuit for passive antenna and LNA. By default, C1 and C2 are not mounted; R1 is 0 ohm. C3 is reserved for impedance matching between LNA and L76 series module and the default value of C3 capacitor is 56pF which you might optimize according to the real conditions. ANTON is an optional pin which can be used to control the enable pin of an external LNA.

NOTES

1. There is no need to use an external LNA for L76-L module, because an embedded LNA is already used inside the module.
2. The selected LNA should support both GPS and GLONASS system. LNA from Maxim (<http://para.maximintegrated.com>) or from Infineon (<http://www.infineon.com>) is recommended to be used here. For more details, please contact Quectel technical supports.
3. The power consumption of the device will be reduced by controlling "LNA ENABLE" through the pin "ANTON" of L76 series module. If "ANTON" function is not used, please connect the pin "LNA ENABLE" to VCC and keep LNA always on.

5 Electrical, Reliability and Radio Characteristics

5.1. Absolute Maximum Ratings

Absolute maximum rating for power supply and voltage on digital pins of the module are listed in following table.

Table 9: Absolute Maximum Ratings

Parameter	Min.	Max.	Unit
Power Supply Voltage (VCC)	-0.3	4.5	V
Backup Battery Voltage (V_BCKP)	-0.3	4.5	V
Input Voltage at Digital Pins	-0.3	3.6	V
Input Power at RF_IN (PRF_IN)		15	dBm
Storage Temperature	-45	125	°C

NOTE

Stressing the device beyond the “Absolute Maximum Ratings” may cause permanent damage. These are stress ratings only. The product is not protected against over voltage or reversed voltage. If necessary, voltage spikes exceeding the power supply voltage specification, given in table above, must be limited to values within the specified boundaries by using appropriate protection diodes.

5.2. Operating Conditions

Table 10: Power Supply Ratings

Parameter	Description	Conditions	Min.	Type.	Max.	Unit
VCC	Supply voltage	Voltage must stay within the min/max values, including voltage drop, ripple, and spikes.	2.8	3.3	4.3	V
I _{VCCP}	Peak supply current	VCC=3.3V			150	mA
V_BCKP	Backup voltage supply		1.5	3.3	4.5	V
VCC_RF	Output voltage of RF section				VCC	V
TOPR	Full on mode operating temperature		-45	25	85	°C

NOTES

1. These figures can be used to determine the maximum current capability of power supply.
2. Operation beyond the "Operating Conditions" is not recommended and extended exposure beyond the "Operating Conditions" may affect device reliability.

5.3. Current Consumption

The values for current consumption are shown in the following table.

Table 11: Current Consumption

Module	Conditions	Acquisition @3.3V	Tracking @3.3V	Standby @3.3V	Backup @V_BCKP=3.3V
L76	@-130dBmGPS	21mA	15mA	0.5mA	7uA
	@-130dBmGPS+GLONASS	25mA	18mA		
L76-L	@-130dBm GPS	25mA	19mA	0.5mA	7uA
	@-130dBm GPS+GLONASS	29mA	22mA		

L76B	@-130dBm GPS	21mA	15mA	0.5mA	7uA
	@-130dBm GPS+BeiDou	23mA	18mA		

NOTES

1. The power of the embedded LNA inside L76-L will be cut off automatically once the module enters into Standby mode or Backup mode.
2. The VCC_RF current is not reckoned in above consumption.
3. The tracking current is tested in the following conditions:
 - In Cold Start, 10 minutes after First Fix.
 - In Hot Start, 15 seconds after First Fix.

5.4. Reliability Test

Table 12: Reliability Test

Test item	Conditions	Standard
Thermal Shock	-30°C...+80°C, 144 cycles	GB/T 2423.22-2002 Test Na IEC 68-2-14 Na
Damp Heat, Cyclic	+55°C; >90% Rh 6 cycles for 144 hours	IEC 68-2-30 Db Test
Vibration Shock	5~20Hz, 0.96m2/s3; 20~500Hz, 0.96m2/s3-3dB/oct, 1hour/axis; no function	2423.13-1997 Test Fdb IEC 68-2-36 Fdb Test
Heat Test	85°C, 2 hours, operational	GB/T 2423.1-2001 Ab IEC 68-2-1 Test
Cold Test	-40°C, 2 hours, operational	GB/T 2423.1-2001 Ab IEC 68-2-1 Test
Heat Soak	90°C, 72 hours, non-operational	GB/T 2423.2-2001 Bb IEC 68-2-2 Test B
Cold Soak	-45°C, 72 hours, non-operational	GB/T 2423.1-2001 A IEC 68-2-1 Test

6 Mechanical Dimensions

This chapter describes the mechanical dimensions of L76 series module.

6.1. Mechanical Dimensions of the Module

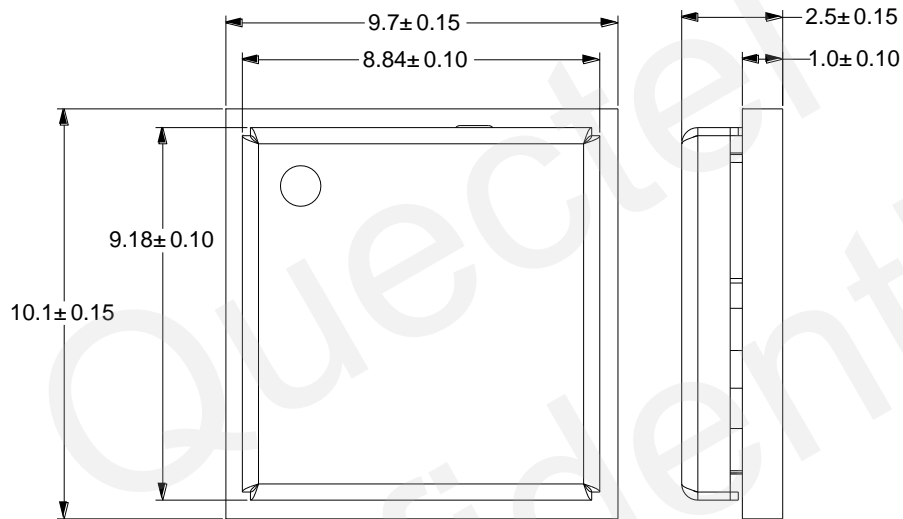

Figure 18: Top and Side Dimensions (Unit: mm)

6.2. Bottom Dimensions and Recommended Footprint

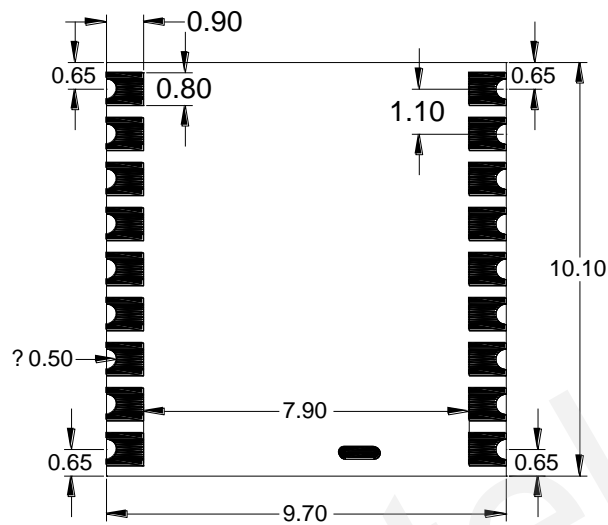

Figure 19: Bottom Dimensions (Unit: mm)

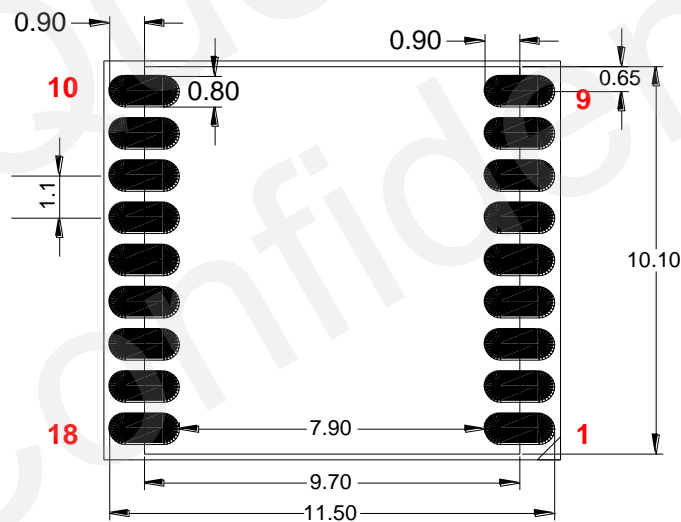

Figure 20: Recommended Footprint (Unit: mm)

NOTE

For easy maintenance of this module and easy accessing to these pads, please keep a distance of no less than 3mm between the module and other components in host board.

6.3. Top and Bottom View of the Module

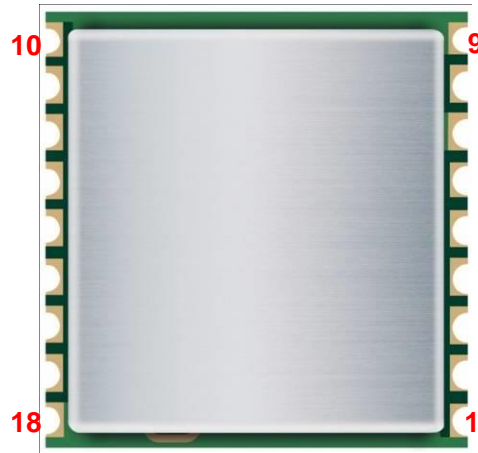

Figure 21: Top View of the Module

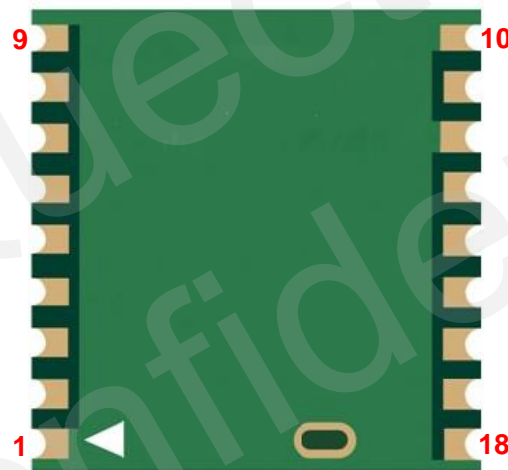

Figure 22: Bottom View of the Module

NOTE

These are design effect drawings of L76 series module. For more accurate pictures, please refer to the module that you get from Quectel.

7 Manufacturing, Packaging and Ordering Information

7.1. Assembly and Soldering

L76 series GNSS module is intended for SMT assembly and soldering in a Pb-free reflow process on the top side of the PCB. It is suggested that the minimum height of solder paste stencil is 130um to ensure sufficient solder volume. Pad openings of paste mask can be increased to ensure proper soldering and solder wetting over pads. It is suggested that the peak reflow temperature is from 235 to 245°C (for SnAg3.0Cu0.5 alloy). The absolute maximum reflow temperature is 260°C. To avoid damage to the module when it is repeatedly heated, it is suggested that the module should be mounted after reflow soldering for the other side of PCB has been completed. Recommended reflow soldering thermal profile is shown below:

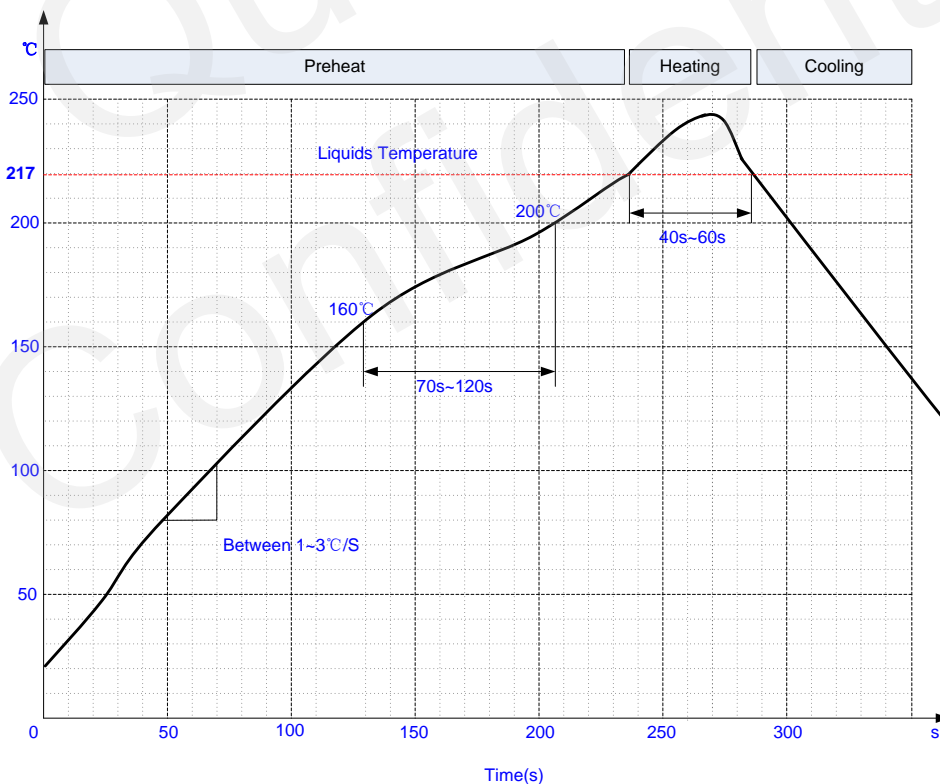

Figure 23: Recommended Reflow Soldering Thermal Profile

7.2. Moisture Sensitivity

L76 series GNSS module is sensitive to moisture. To prevent L76 series GNSS module from permanent damage during reflow soldering, baking before reflow soldering is required in the following cases:

- Humidity indicator card: One or more indicating spots are no longer blue.
- The seal is opened and the module is exposed to excessive humidity.

L76 series GNSS module should be baked for 192 hours at temperature $40^{\circ}\text{C}+5^{\circ}\text{C}/-0^{\circ}\text{C}$ and $<5\%$ RH in low-temperature containers, or 24 hours at temperature $125^{\circ}\text{C}\pm 5^{\circ}\text{C}$ in high-temperature containers. Care should be taken that the plastic tape is not heat resistant. L76 series GNSS module should be taken out from the tape before preheating; otherwise, the tape maybe damaged by high-temperature heating.

7.3. ESD Protection

L76 series GNSS module is an ESD sensitive device. ESD protection precautions should be emphasized. Proper ESD handling and packaging procedures must be applied throughout the processing, handling and operation of any application. Please note that the following measures are good for ESD protection during module handling.

Unless there is a galvanic coupling between the local GND and the PCB GND, the first point of contact shall always be between the local GND and PCB GND when handling the PCB.

Before mounting the RF_IN pad, please make sure the GND of the module has been connected.

Do not contact any charged capacitors or materials which can easily develop or store charges (such as patch antenna, coax cable, soldering iron) when handling with the RF_IN pad.

To prevent electrostatic discharge from the RF input, please do not touch any exposed area of the mounted patch antenna.

Make sure to use an ESD safe soldering iron (tip) when soldering the RF_IN pin.

7.4. Tape and Reel Packaging

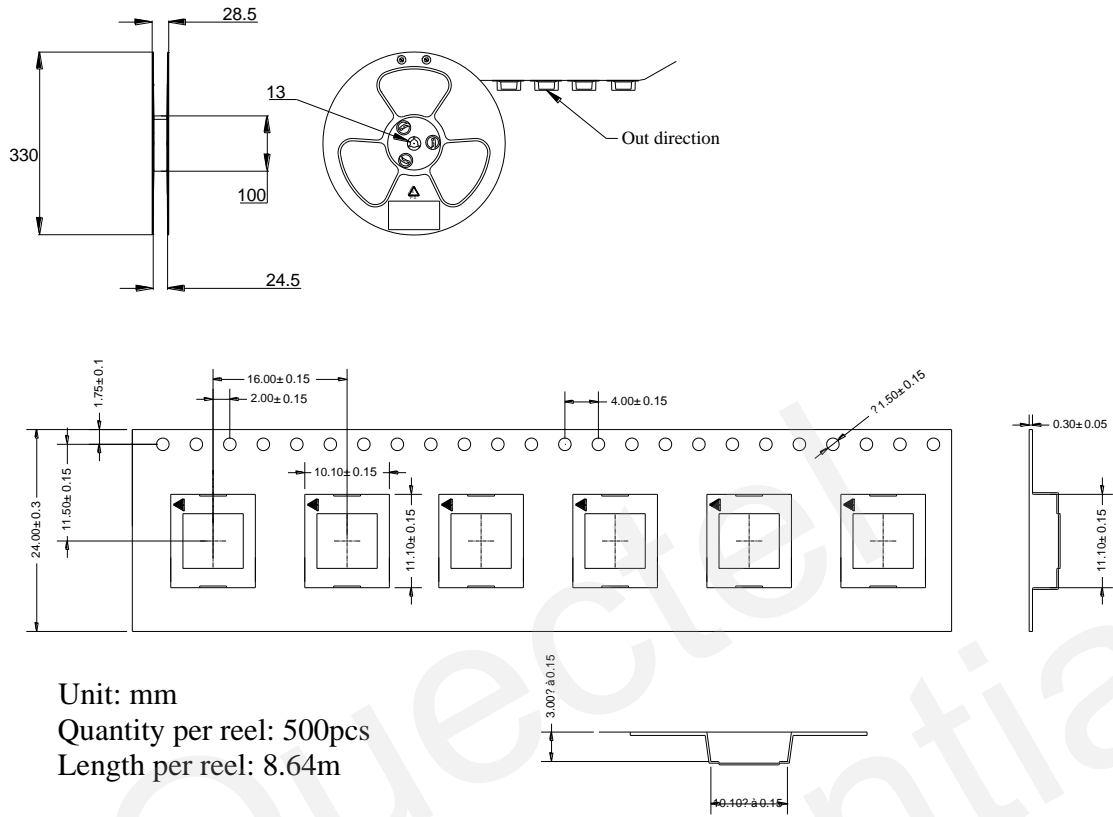

Figure 24: Tape and Reel Specifications

Table 13: Reel Packaging

Model Name	MOQ for MP	Minimum Package: 500pcs	Minimum Packagex4 = 2000pcs
L76/L76-L/L76B	500pcs	Size: 370mm × 350mm × 56mm N.W: 0.25kg G.W: 1.00kg	Size: 380mm × 250mm × 365mm N.W: 1.1kg G.W: 4.4kg

7.5. Ordering Information

Table 14: Ordering Information

Model Name	Ordering Code
L76	L76-M33
L76-L	L76L-M33
L76B	L76B-M33

Quectel
Confidential

8 Appendix References

Table 15: Related Documents

SN	Document Name	Remark
[1]	Quectel_L76_Series_EVB_User_Guide	L76 Series EVB User Guide
[2]	Quectel_L76_Series_GNSS_Protocol_Specification	L76 Series GNSS Protocol Specification
[3]	Quectel_L76_Series_Reference_Design	L76 Series Reference Design
[4]	Quectel_GNSS_EPO_Application_Note	GNSS EPO Application Note
[5]	Quectel_GNSS_I2C_Application_Note	I2C Application Note
[6]	Quectel_GNSS_SDK_Commands_Manual	GNSS SDK Commands Manual

Table 16: Terms and Abbreviations

Abbreviation	Description
AGPS	Assisted GPS
AIC	Active Interference Cancellation
CEP	Circular Error Probable
DGPS	Differential GPS
EASY	Embedded Assist System
EGNOS	European Geostationary Navigation Overlay Service
EMC	Electromagnetic Compatibility
EPO	Extended Prediction Orbit
ESD	Electrostatic Discharge
GPS	Global Positioning System

GNSS	Global Navigation Satellite System
GGA	GPS Fix Data
GLL	Geographic Position – Latitude/Longitude
GLONASS	GLOBAL NAVIGATION SATELLITE SYSTE
GSA	GNSS DOP and Active Satellites
GSV	GNSS Satellites in View
HDOP	Horizontal Dilution of Precision
IC	Integrated Circuit
I/O	Input /Output
Kbps	Kilo Bits Per Second
LNA	Low Noise Amplifier
MSAS	Multi-Functional Satellite Augmentation System
MOQ	Minimum Order Quantity
NMEA	National Marine Electronics Association
PDOP	Position Dilution of Precision
PMTK	MTK Proprietary Protocol
PPS	Pulse Per Second
PQ	Quectel Proprietary Protocol
PRN	Pseudo Random Noise Code
QZSS	Quasi-Zenith Satellite System
RHCP	Right Hand Circular Polarization
RMC	Recommended Minimum Specific GNSS Data
RTCM	Radio Technical Commission for Maritime Services
SBAS	Satellite-based Augmentation System
SAW	Surface Acoustic Wave
TTF	Time To First Fix

UART	Universal Asynchronous Receiver & Transmitter
VDOP	Vertical Dilution of Precision
VTG	Course over Ground and Ground Speed, Horizontal Course and Horizontal Velocity
WAAS	Wide Area Augmentation System
Inom	Nominal Current
I _{max}	Maximum Load Current
V _{max}	Maximum Voltage Value
V _{nom}	Nominal Voltage Value
V _{min}	Minimum Voltage Value
V _{IHmax}	Maximum Input High Level Voltage Value
V _{IHmin}	Minimum Input High Level Voltage Value
V _{ILmax}	Maximum Input Low Level Voltage Value
V _{ILmin}	Minimum Input Low Level Voltage Value
V _{Imax}	Absolute Maximum Input Voltage Value
V _{Imin}	Absolute Minimum Input Voltage Value
V _{OHmax}	Maximum Output High Level Voltage Value
V _{OHmin}	Minimum Output High Level Voltage Value
V _{OLmax}	Maximum Output Low Level Voltage Value
V _{OLmin}	Minimum Output Low Level Voltage Value