

Product name	Description	Version
LS23030-G	Multiple GNSS mouse/ MTK3333,2m,USB,9600BPS (PPS over USB)	1.5
LS23032-G	Multiple GNSS mouse/ MTK3333,2m,PS2,9600BPS	
LS23033-G	Multiple GNSS mouse/ MTK3333,3m,RJ11,9600BPS	
LS23035-G	Multiple GNSS mouse/ MTK3333,5m,PS2 with lock,9600BPS	
LS23036-G	Multiple GNSS mouse/ MTK3333,3m,RJ11,9600BPS	

Note: LS23036-G is most popular. We recommend customers to use for new design.

Datasheet of multiple GNSS mouse, LS2303x-G series



1 Introduction

LS2303x-G series products are complete GNSS receivers (also known as GNSS mouse) based on the proven technology found in LOCOSYS GNSS module MC-1612-G that uses MediaTek chip solution. The GNSS mouse will acquire a lot of satellites at a time while providing fast Time-To-First-Fix, one-second navigation update and low power consumption. It can provide you with superior sensitivity and performance even in urban canyon and dense foliage environment. Its far-reaching capability meets the sensitivity requirements of car navigation as well as other location-based applications.

2 Features

- MediaTek high sensitivity solution
- Support GPS, GLONASS, GALILEO and QZSS
- Capable of SBAS (WAAS, EGNOS, MSAS, GAGAN)
- Support 99-channel GNSS
- Ultra low power consumption
- Fast TTFF at low signal level
- Built-in 12 multi-tone active interference canceller
- Free hybrid AGPS to achieve faster cold start
- Built-in data logger
- Up to 10 Hz update rate
- 1 PPS over USB for timing application
- Linux/Android support
- Compatible with GPSD PPS support

- Indoor and outdoor multi-path detection and compensation
- Build-in micro battery to reserve system data for rapid satellite acquisition
- LED indicator of GNSS positioning status
- Magnet for mounting on the car
- Waterproof

3 Application

- Personal positioning and navigation
- Automotive navigation
- Marine navigation
- High-Quality NTP time server

4 GNSS receiver

Chip	MediaTek MT3333	
Frequency	GPS, GALILEO ⁽¹⁾ , QZSS: L1 1575.42MHz, C/A code GLONASS: L1 1598.0625MHz ~ 1605.375MHz, C/A code	
Channels	Support 99 channels (33 Tracking, 99 Acquisition)	
Update rate	1Hz default, up to 10Hz	
Acquisition Time	Hot start (Open Sky)	1s (typical)
	Cold Start (Open Sky)	33s (typical) without AGPS
		< 15s (typical) with AGPS (hybrid ephemeris prediction)
Position Accuracy	Autonomous	2.5m CEP
	SBAS	2.5m (depends on accuracy of correction data)
PPS Signal Accuracy	Chip level +/- 25ns , 1ms for PPS over USB ⁽²⁾	
Datum	WGS-84 (default)	
Max. Altitude	< 18,000 m, up to 50,000m by request	
Max. Velocity	< 515 m/s	
Protocol	NMEA 0183 ver 4.00 ⁽³⁾	9600 bps ⁽⁴⁾ , 8 data bits, no parity, 1 stop bits 1Hz: GGA, GLL, GSA, GSV, RMC, VTG

Note (1): LS2303x-G series products are default configured for concurrent GPS, GLONASS, QZSS and SBAS reception. Please contact us for different default configuration, such as concurrent GPS, GLONASS, GALILEO, QZSS and SBAS.

Note (2): The LS23030-G makes PPS events visible for a compatible USB host system; they appear DCD state changes to the PL2303 driver. Its time precision will be limited by the USB pooling interval, usually 1 millisecond.

Note (3): The default NMEA version is 4.00 and it also can configure to 4.10. If customers want to the product to support 4.10 please contact us in advance.

Note (4): Both baud rate and output message rate are configurable to be factory default.

5 Software interface

5.1 NMEA output message

Table 5.1-1 NMEA output message

NMEA record	Description
GGA	Global positioning system fixed data
GLL	Geographic position - latitude/longitude
GSA	GNSS DOP and active satellites
GSV	GNSS satellites in view
RMC	Recommended minimum specific GPS data
VTG	Course over ground and ground speed

● GGA--- Global Positioning System Fixed Data

Table 5.1-2 contains the values for the following example:

\$GNGGA,183015.000,2503.7123,N,12138.7446,E,2,16,0.68,123.2,M,15.3,M,,*78

Table 5.1-2 GGA Data Format

Name	Example	Units	Description
Message ID	\$GNGGA		GGA protocol header
UTC Time	183015.000		hhmmss.sss
Latitude	2503.7123		ddmm.mmmm
N/S indicator	N		N=north or S=south
Longitude	12138.7446		dddmm.mmmm
E/W Indicator	E		E=east or W=west
Position Fix Indicator	2		See Table 5.1-3
Satellites Used	16		Range 0 to 33
HDOP	0.68		Horizontal Dilution of Precision
MSL Altitude	123.2	meters	
Units	M	meters	
Geoid Separation	15.3	meters	
Units	M	meters	
Age of Diff. Corr.		second	Null fields when DGPS is not used
Diff. Ref. Station ID			
Checksum	*78		
<CR> <LF>			End of message termination

Table 5.1-3 Position Fix Indicators

Value	Description
0	Fix not available or invalid
1	GPS SPS Mode, fix valid

2	Differential GPS, SPS Mode, fix valid
3-5	Not supported
6	Dead Reckoning Mode, fix valid

● GLL--- Geographic Position – Latitude/Longitude

Table 5.1-4 contains the values for the following example:

\$GNGLL,2503.7135,N,12138.7448,E,055757.000,A,D*45

Table 5.1-4 GLL Data Format

Name	Example	Units	Description
Message ID	\$GNGLL		GLL protocol header
Latitude	2503.7135		ddmm.mmmm
N/S indicator	N		N=north or S=south
Longitude	12138.7448		dddmm.mmmm
E/W indicator	E		E=east or W=west
UTC Time	055757.000		hhmmss.sss
Status	A		A=data valid or V=data not valid
Mode	D		N = No position fix A = Autonomous GNSS fix D = Differential GNSS fix R = RTK fixed F = RTK float E = Estimated/Dead reckoning fix
Checksum	*45		
<CR> <LF>			End of message termination

● GSA---GNSS DOP and Active Satellites

Table 5.1-5 contains the values for the following example:

```
NMEA V4.0
$GPGSA,A,3,193,19,06,05,02,17,09,12,13,195,,1.23,0.92,0.81*01
$GLGSA,A,3,69,,,,,,,,,1.23,0.92,0.81*13
$GAGSA,A,3,,,,,,,,,1.23,0.92,0.81*11
NMEA V4.10
$NGGSA,A,3,02,06,17,19,09,05,28,193,195,,1.34,1.02,0.87,1*01
$NGGSA,A,3,69,,,,,,,,,1.34,1.02,0.87,2*07
$NGGSA,A,3,,,,,,,,,1.34,1.02,0.87,3*09
```

Table 5.1-5 GSA Data Format

Name	Example	Units	Description
------	---------	-------	-------------

Message ID	\$GNGSA		GSA protocol header, GP=GPS/QZSS, GL=GLONASS, GA=GALILEO, BD=BEIDOU (GN for NMEA Ver 4.10)
Mode 1	A		See Table 5.1-6
Mode 2	3		See Table 5.1-7
ID of satellite used	02		Sv on Channel 1
ID of satellite used	06		Sv on Channel 2
....		
ID of satellite used			Sv on Channel 12
PDOP	1.34		Position Dilution of Precision
HDOP	1.02		Horizontal Dilution of Precision
VDOP	0.87		Vertical Dilution of Precision
System ID	1		1: GPS, 2:GLONASS, 3:GALILEO, 4:BEIDOU (NMEA Ver 4.10 support only)
Checksum	*01		
<CR> <LF>			End of message termination

Table 5.1-6 Mode 1

Value	Description
M	Manual- forced to operate in 2D or 3D mode
A	Automatic-allowed to automatically switch 2D/3D

Table 5.1-7 Mode 2

Value	Description
1	Fix not available
2	2D
3	3D

● GSV---GNSS Satellites in View

Table 5.1-8 contains the values for the following example:

```
$GPGSV,3,1,11,18,67,344,48,09,55,031,50,42,54,142,40,193,47,174,45,0*51
$GPGSV,3,2,11,21,44,219,46,27,39,035,48,12,34,131,44,15,30,057,46,0*6A
$GPGSV,3,3,11,22,27,319,47,14,22,285,42,25,19,171,40,0*58
$GLGSV,2,1,07,76,71,201,44,65,57,041,40,75,48,028,39,72,27,108,39,1*75
$GLGSV,2,2,07,66,25,333,43,77,17,207,37,81,02,280,29,1*41
$GAGSV,2,1,05,01,83,026,35,26,53,024,35,21,38,134,30,12,16,233,21,0*70
$GAGSV,2,2,05,18,,,30,0*7B
```

Table 5.1-8 GSV Data Format

Name	Example	Units	Description
------	---------	-------	-------------

Message ID	\$GPGSV		GSV protocol header GP=GPS/QZSS, GL=GLONASS, GA=GALILEO, BD=BEIDOU
Total number of messages ⁽¹⁾	3		Range 1 to 6
Message number ⁽¹⁾	1		Range 1 to 6
Satellites in view	11		
Satellite ID ⁽²⁾	18		Channel 1 (Range 01 to 196)
Elevation	67	degrees	Channel 1 (Range 00 to 90)
Azimuth	344	degrees	Channel 1 (Range 000 to 359)
SNR (C/No)	48	dB-Hz	Channel 1 (Range 00 to 99, null when not tracking)
Satellite ID	09		Channel 4 (Range 01 to 196)
Elevation	55	degrees	Channel 4 (Range 00 to 90)
Azimuth	031	degrees	Channel 4 (Range 000 to 359)
SNR (C/No)	50	dB-Hz	Channel 4 (Range 00 to 99, null when not tracking)
	...		
Signal ID	0		GPS/QZSS: All signal=0, GLONASS: All signal=0, G1 C/A=1 GALILEO: All signal=0, BEIDOU: All signal=0 (NMEA Ver 4.10 support only)
Checksum	*51		
<CR> <LF>			End of message termination

Note (1): Depending on the number of satellites tracked multiple messages of GSV data may be required.

Note (2): GPS ID: 01~32, SBAS ID: 33~64, QZSS ID: 193~196, BEIDOU ID: 01~32, GALILEO ID: 01~32.

● RMC---Recommended Minimum Specific GNSS Data

Table 5.1-9 contains the values for the following example:

\$GNRMC,183015.000,A,2503.7123,N,12138.7446,E,0.01,34.92,270812,,,D,V*39

Table 5.1-9 RMC Data Format

Name	Example	Units	Description
Message ID	\$GNRMC		RMC protocol header
UTC Time	183015.000		hhmmss.sss
Status	A		A=data valid or V=data not valid
Latitude	2503.7123		ddmm.mmmm
N/S Indicator	N		N=north or S=south
Longitude	12138.7446		dddmm.mmmm
E/W Indicator	E		E=east or W=west
Speed over ground	0.01	knots	True

Course over ground	34.92	degrees	
Date	270812		ddmmyy
Magnetic variation		degrees	
Variation sense			E=east or W=west (Not shown)
Mode	D		N = No position fix A = Autonomous GNSS fix D = Differential GNSS fix R = RTK fixed F = RTK float E = Estimated/Dead reckoning fix
Navigational status indicator	V		S = Safe C = Caution U = Unsafe V = Void (NMEA Ver 4.10 support only)
Checksum	*39		
<CR> <LF>			End of message termination

● VTG---Course Over Ground and Ground Speed

Table 5.1-10 contains the values for the following example:

\$GNVTG,196.90,T,,M,0.01,N,0.01,K,D*21

Table 5.1-10 VTG Data Format

Name	Example	Units	Description
Message ID	\$GNVTG		VTG protocol header
Course over ground	196.90	degrees	Measured heading
Reference	T		True
Course over ground		degrees	Measured heading
Reference	M		Magnetic
Speed over ground	0.01	knots	Measured speed
Units	N		Knots
Speed over ground	0.01	km/hr	Measured speed
Units	K		Kilometer per hour
Mode	D		N = No position fix A = Autonomous GNSS fix D = Differential GNSS fix R = RTK fixed F = RTK float

			E = Estimated/Dead reckoning fix
Checksum	*21		
<CR> <LF>			End of message termination

5.2 Proprietary NMEA input message

Please refer to MTK proprietary message.

5.3 Examples to configure the power mode of GNSS module

5.3.1 Standby mode

User can issue software command to make GNSS module go into standby mode that consumes less than 500uA current. GNSS module will be awaked when receiving any byte. The following flow chart is an example to make GNSS module go into standby mode and then wake up.

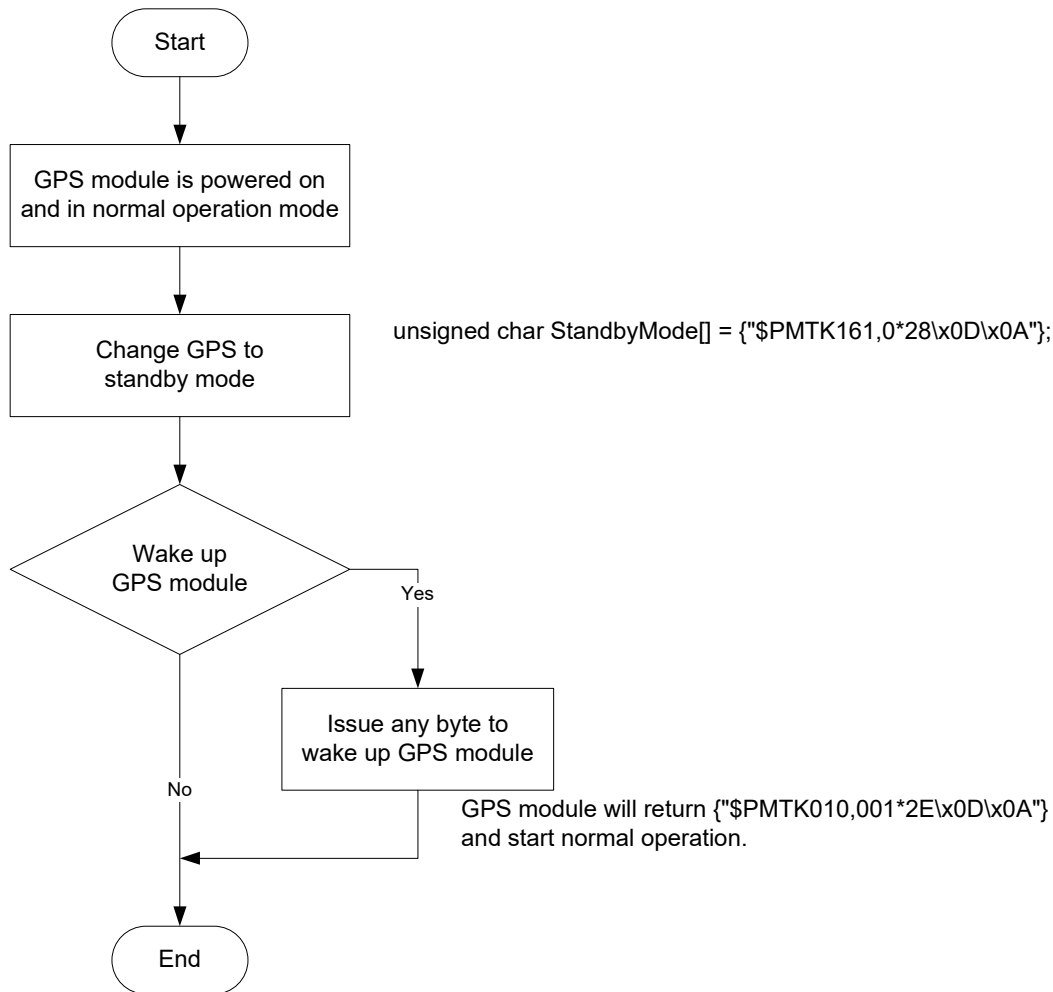

5.3.2 Periodic mode

When GNSS module is commanded to periodic mode, it will be in operation and standby periodically. Its status of power consumption is as below chart.

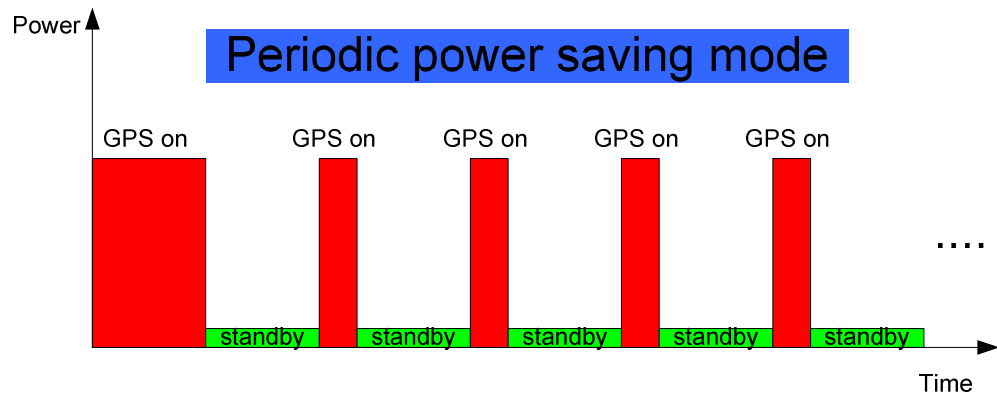

The following flow chart is an example to make GNSS module go into periodic mode and then back to normal operation mode.

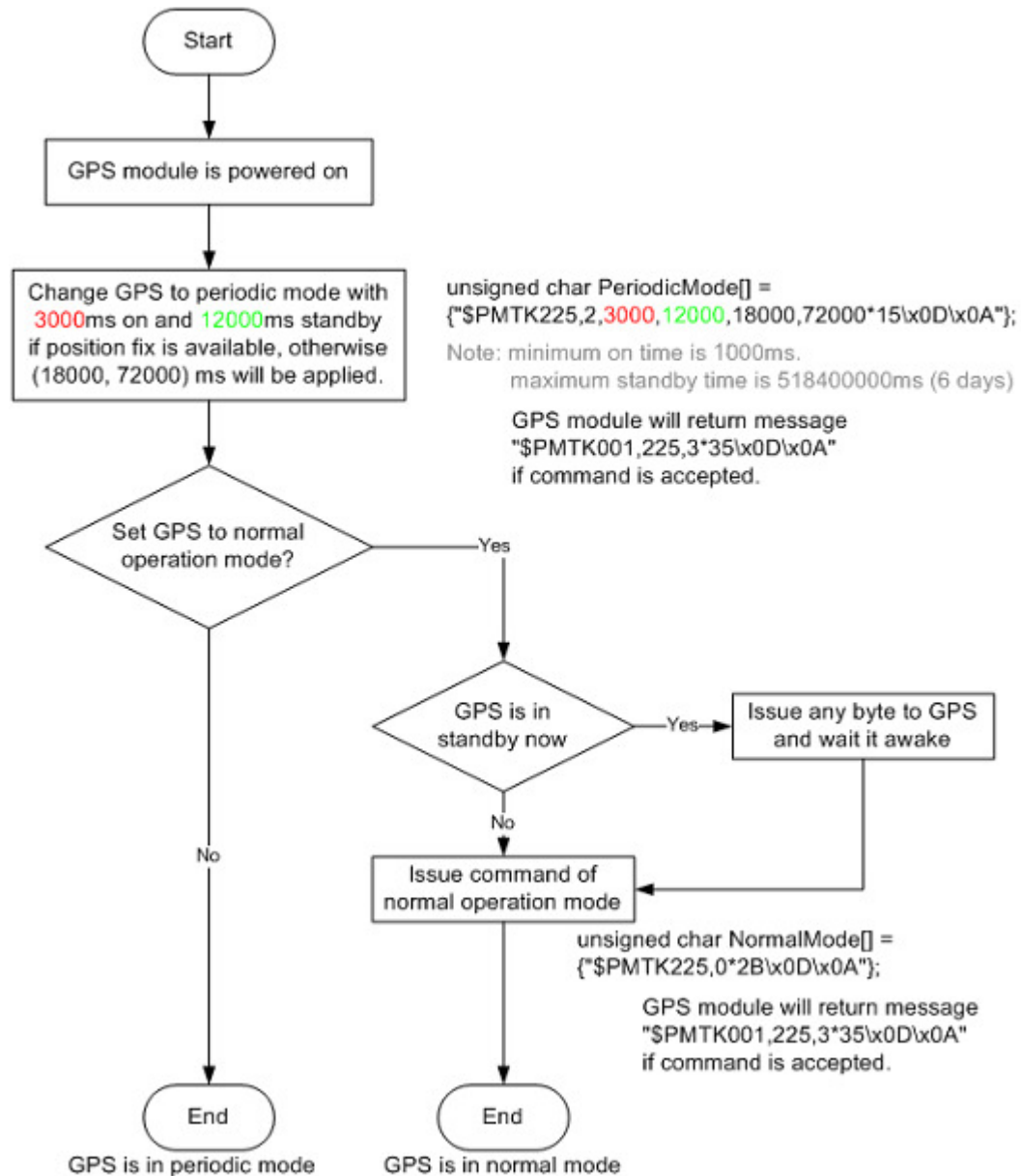

5.3.3 AlwaysLocate™ mode

AlwaysLocate™ is an intelligent controller of periodic mode. Depending on the environment and motion conditions, GNSS module can adaptively adjust working/standby time to achieve balance of positioning accuracy and power consumption. In this mode, the host CPU does not need to control GNSS module until the host CPU needs the GNSS position data. The following flow chart is an example to make GNSS module go into AlwaysLocate™ mode and then back to normal operation mode.

Note: AlwaysLocate™ is a trade mark of MTK.

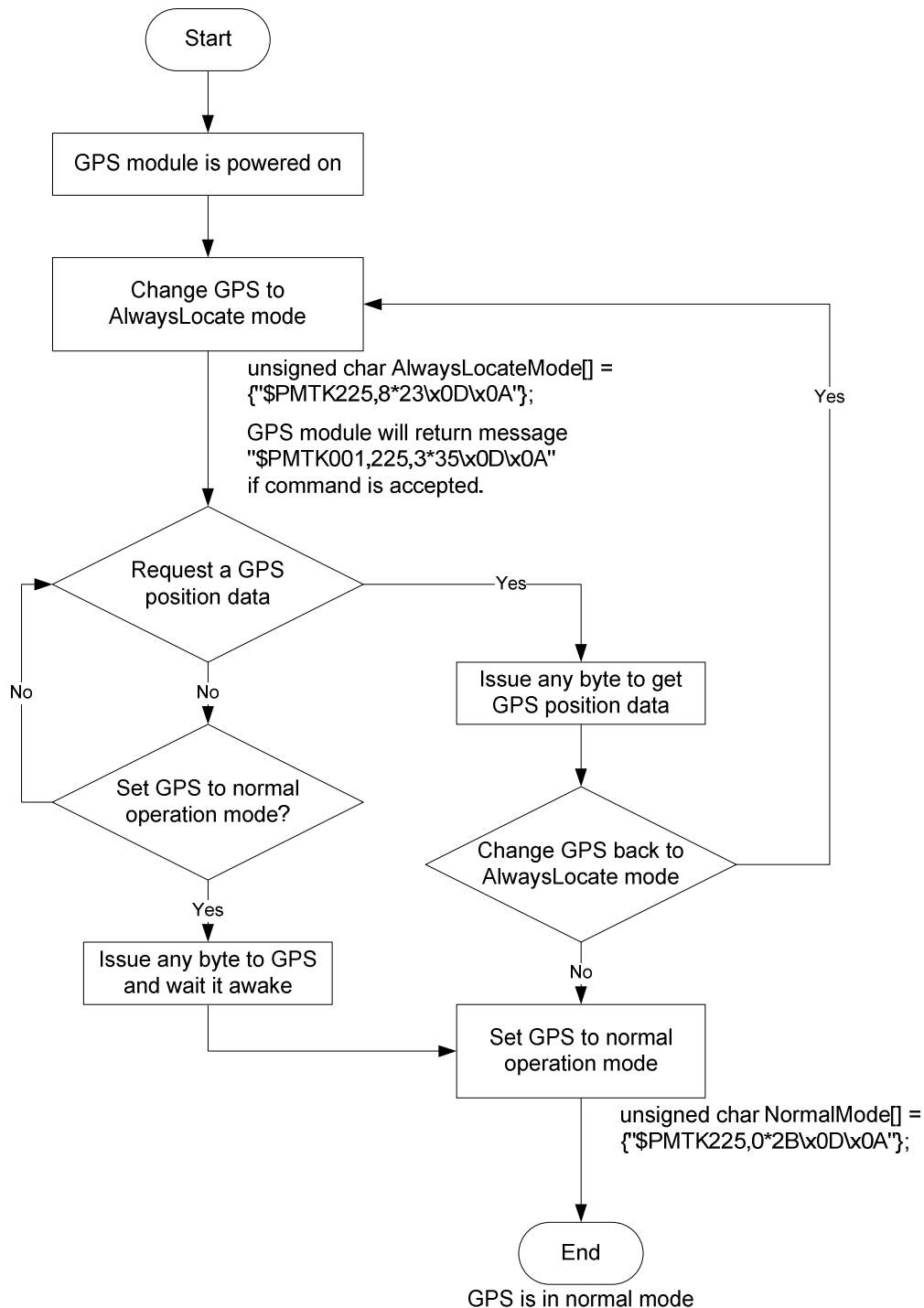

5.4 Data logger

The GNSS module has internal flash memory for logging GNSS data. The configurations include time interval, distance, speed, logging mode, and ... etc. For more information, please contact us.

5.5 Examples to configure the update rate of GNSS module

The GNSS module supports up to 10Hz update rate that user can configure by issuing software commands. Note that the configurations by software commands are stored in the battery-backed SRAM that is powered through VBACKUP pin. Once it drains out, the default/factory settings will be applied.

Due to the transmitting capacity per second of the current baud rate, GNSS module has to be changed to higher baud rate for high update rate of position fix. The user can use the following software commands to change baud rate.

Baud rate	Software command
Factory default	\$PMTK251,0*28<CR><LF>
4800	\$PMTK251,4800*14<CR><LF>
9600	\$PMTK251,9600*17<CR><LF>
19200	\$PMTK251,19200*22<CR><LF>
38400	\$PMTK251,38400*27<CR><LF>
57600	\$PMTK251,57600*2C<CR><LF>
115200	\$PMTK251,115200*1F<CR><LF>

Note: <CR> means Carriage Return, i.e. 0x0D in hexadecimal. <LF> means Line Feed, i.e. 0x0A in hexadecimal.

If the user does not want to change baud rate, you can reduce the output NMEA sentences by the following software commands.

NMEA sentence	Software command
Factory default	\$PMTK314,-1*04<CR><LF>
Only GLL at 1Hz	\$PMTK314,1,0,0,0,0,0,0,0,0,0,0,0,0,0,0*29<CR><LF>
Only RMC at 1Hz	\$PMTK314,0,1,0,0,0,0,0,0,0,0,0,0,0,0,0*29<CR><LF>
Only VTG at 1Hz	\$PMTK314,0,0,1,0,0,0,0,0,0,0,0,0,0,0,0*29<CR><LF>
Only GGA at 1Hz	\$PMTK314,0,0,0,1,0,0,0,0,0,0,0,0,0,0,0*29<CR><LF>
Only GSA at 1Hz	\$PMTK314,0,0,0,0,1,0,0,0,0,0,0,0,0,0,0*29<CR><LF>
Only GSV at 1Hz	\$PMTK314,0,0,0,0,0,1,0,0,0,0,0,0,0,0,0*29<CR><LF>
Only ZDA at 1Hz	\$PMTK314,0,0,0,0,0,0,0,0,0,0,0,0,0,0,1*29<CR><LF>
RMC, GGA, GSA at 1Hz and GSV at	\$PMTK314,0,1,0,1,1,5,0,0,0,0,0,0,0,0,0*2C<CR><LF>

0.2Hz	
If the command is correct and executed, GNSS module will output message \$PMTK001,314,3*36<CR><LF>	

After the GNSS module is changed to higher baud rate or reduced NMEA sentence, the user can configure it to high update rate of position fix by the following commands.

Interval of position fix	Software command
Every 100ms (10Hz) ⁽¹⁾	\$PMTK220,100*2F<CR><LF>
Every 200ms (5Hz)	\$PMTK220,200*2C<CR><LF>
Every 500ms (2Hz)	\$PMTK220,500*2B<CR><LF>
Every 1000ms (1Hz)	\$PMTK220,1000*1F<CR><LF>
Every 2000ms (0.5Hz) ⁽²⁾	\$PMTK220,2000*1C<CR><LF>
If the command is correct and executed, GNSS module will output message \$PMTK001,220,3*30<CR><LF>	

Note 1: The minimum interval of position fix is 100ms, i.e. the maximum update rate is 10Hz.

Note 2: The current consumption is the same with the update rate of 1Hz.

5.6 Configure the static navigation parameter

The output position of GNSS module will keep the same and output speed will be zero if the actual speed is below the threshold of the static navigation parameter. This is useful for different applications. For example, the car stopped at a red light will get stationary GNSS position if the threshold is 1.5m/s. It is better to disable this function by setting threshold to 0 for pedestrian navigation.

The format of the software command is as below.

\$PMTK386,speed threshold*checksum<CR><LF>

The unit of speed threshold is meter per second. The range of speed threshold is from 0.1m/s to 2.0m/s. Value 0 is to disable the function.

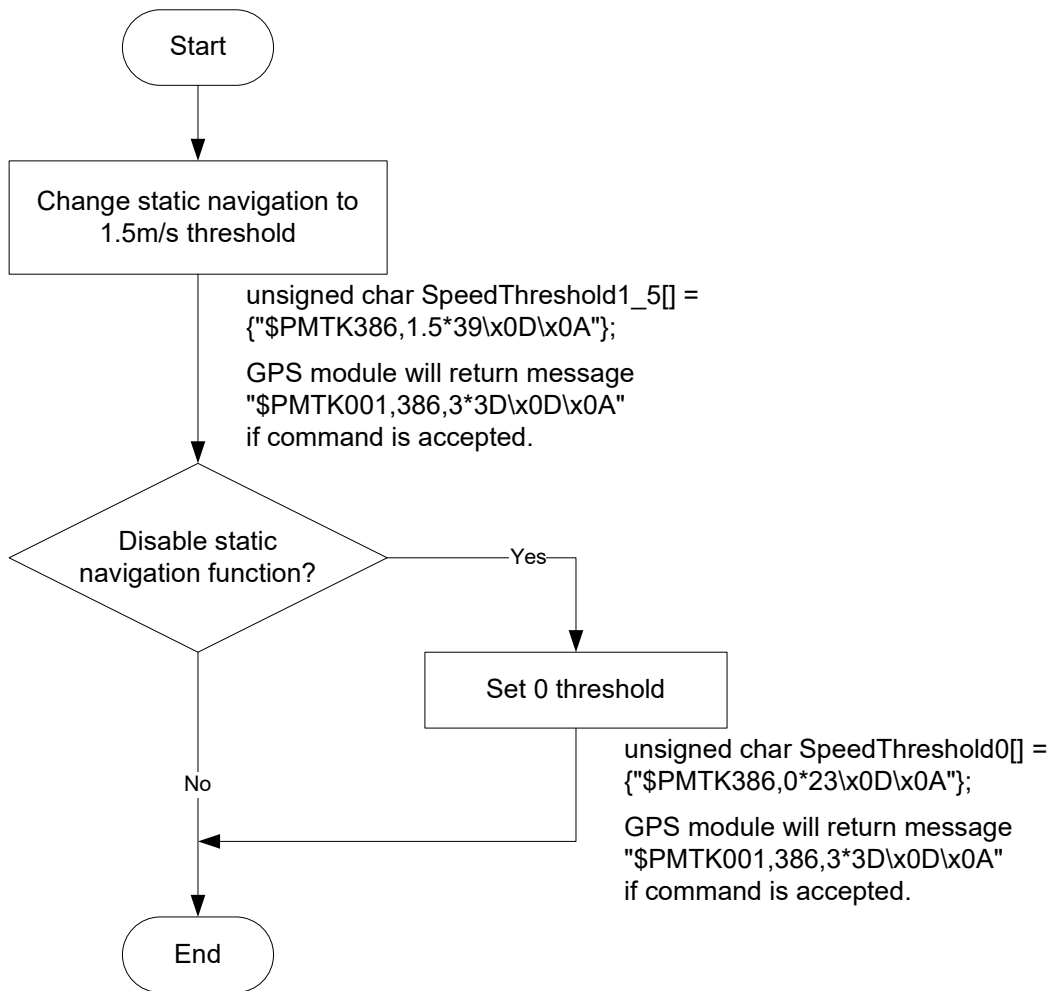

6 How to make sure LS23030-G's PPS over USB is working in Linux Ubuntu?

GPSD is daemon which uses to handle the NMEA and PPS information on Linux system. The GPSD client application called "gpsmon" could be used to check if PPS is working in Linux Ubuntu version 16.04.4. "gpsmon" is a monitor that watches packets coming from a GPS and displays them along with diagnostic information. Here provides some steps for installation of GPSD and verifying PPS performance on Linux system. User can check if a GPSD program has been installation on the Ubuntu. Using following command to determine if GPSD is running in system.

\$ps ax | grep gps

```

cloud@CloudxUBT: ~
cloud@CloudxUBT:~$ ps ax | grep gps
19446 ?        S<sl    0:00  /usr/sbin/gpsd -N -n /dev/ttyUSB0
19482 pts/4    S+      0:00  gpsmon
19504 pts/17   S+      0:00  grep --color=auto gps
    
```

User should install the GPSD package by following commands if it does not installation in Ubuntu.

\$sudo apt-get update

\$sudo apt-get install gpsd-clients gpsd

```
cloud@CloudxUBT:~$ sudo apt-get update
Hit:1 http://tw.archive.ubuntu.com/ubuntu xenial InRelease
Hit:2 http://tw.archive.ubuntu.com/ubuntu xenial-updates InRelease
Hit:3 http://tw.archive.ubuntu.com/ubuntu xenial-backports InRelease
Hit:4 http://security.ubuntu.com/ubuntu xenial-security InRelease
Reading package lists... Done
cloud@CloudxUBT:~$ sudo apt-get install gpsd-clients gpsd
Reading package lists... Done
Building dependency tree
Reading state information... Done
```

Before starting GPSD, LS23030-G should connect to USB port. It normally enumerates a USB device such as "/dev/ttyUSB0" in this case. By using following command to determine device name if module is connecting to host by USB.

\$ls /dev/ttyU*

```
cloud@CloudxUBT:~$ ls /dev/ttyU*
/dev/ttyUSB0
```

Now customer gets the device name as "/dev/ttyUSB0" and checks the GPSD file. By using following command to configure host file at "/etc/default/gpsd".

\$sudo gedit /etc/default/gpsd

```
cloud@CloudxUBT:~$ sudo gedit /etc/default/gpsd
[sudo] password for cloud:
```

Please set the device name (DEVICE="/dev/ttyUSB0") and set GPSD options with the nowait (-n) parameter (GPSD_OPTIONS="-n") as following example then restart the GPSD service.

```
gpsd (/etc/default) - gedit
# Default settings for the gpsd init script and the hotplug wrapper.
# Start the gpsd daemon automatically at boot time
START_DAEMON="true"
# Use USB hotplugging to add new USB devices automatically to the daemon
USBAUTO="true"
# Devices gpsd should collect to at boot time.
# They need to be read/writeable, either by user gpsd or the group dialout.
DEVICES="/dev/ttyUSB0"
# Other options you want to pass to gpsd
GPSD_OPTIONS="-n"
```

\$sudo service gpsd restart

```
cloud@CloudxUBT:~$ sudo service gpsd restart
[sudo] password for cloud:
```

By using following command to check GPSD is working as expected. ("-n" and "/dev/ttyUSB0" parameters)

\$ps aux | grep gpsd

```
cloud@CloudxUBT:~$ ps aux | grep gpsd
gpsd      2786  0.1  0.2 115980  4104 ?        S<s  10:04   0:12 /usr/sbin/gpsd -N -n /dev/ttyUSB0
cloud    3412  0.0  0.0  21572  1084 pts/17   S+   13:37   0:00 grep --color=auto gpsd
```

Execute the GPSD client program.

\$gpsmon

```
cloud@CloudxUBT: ~
/dev/ttyUSB0 u-blox>
Ch PRN Az El S/N Flag U
0
1
2
3
4
5
6
7
8
9
10
11
12
13
14
15
NAF SVINFO
0000000000001000000000000000006900ff0cff000000f722
(26) b5620104120010144d0c750069003300440050000f270f27a510
(24) b5620120100010144d0c90c40500cb07120700000000f208

ECEF Pos: -3033216.97m +4921615.83m +2685348.87m
ECEF Vel: +0.00m/s +0.00m/s +0.01m/s

LTP Pos: 25.061926663° 121.645740207° 121.75m
LTP Vel: 0.01m/s 0.0° 0.00m/s

Time: 23 21:16:20.00
Time GPS: 1995+206378.000 Day: 2

Est Pos Err 2.58m Est Vel Err 0.00m/s
PRNs: 12 PDOP: 1.1 Fix 0x03 Flags 0x0f
NAV_SOL

DOP [H] 0.8 [V] 0.7 [P] 1.1 [T] 0.5 [G] 1.2
NAV_DOP

TOFF: 0.236903389 PPS: 0.009320523
```

As shown above, PPS is detected with delay of 0.009320523 seconds to the local clock while delay of GPS is 0.236903389 seconds (shown by TOFF)

7 LED indicator

The red LED is an indicator of GNSS positioning status. In continuous power mode, it flashes once per second when position is fixed. Otherwise it is off. The timing in detail is as below.

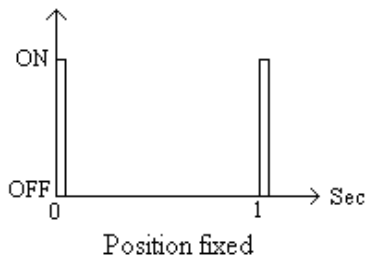

8 Pin assignment and descriptions

- **LS23030-G**

Pin #	Name	Type	Description
1	VBUS	P	USB power input
2	D-		D- line
3	D+		D+ line
4	GND	P	Ground

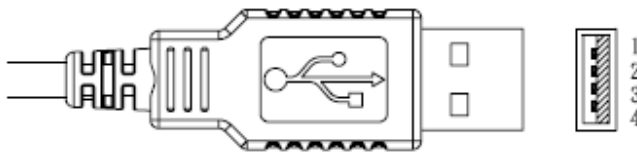

USB A-TYPE Plug

- **LS23032-G**

Pin #	Name	Type	Description
1	GND	P	Ground
2	VDD	P	Power input
3	NC		Not connect
4	RX	I	Data input (RS232 level)
5	TX	O	Data output (RS232 level)
6	NC		Not connect

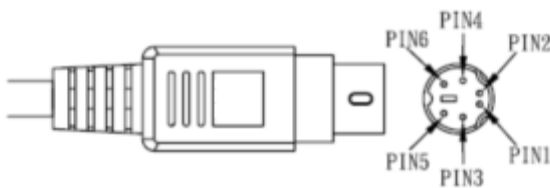

PS2 MALE

- **LS23033-G**

Pin #	Name	Type	Description
1	VDD	P	Power input
2	RX	I	Data input (RS232 level)
3	TX	O	Data output (RS232 level)
4	GND	P	Ground
5	NC		Not connect
6	NC		Not connect

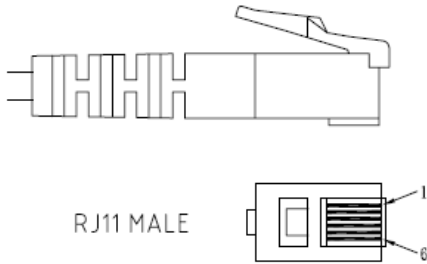

RJ11 MALE

● **LS23035-G**

Pin #	Name	Type	Description
1	VDD	P	Power input
2	GND	P	Ground
3	NC		Not connect
4	TX	O	Data output (RS232 level)
5	RX	I	Data input (RS232 level)
6	NC		Not connect

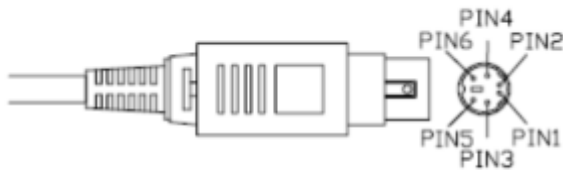

PS2 MALE
with lock

● **LS23036-G**

Pin #	Name	Type	Description
1	NC		Not connect
2	GND	P	Ground
3	RX	I	Data input (RS232 level)
4	TX	O	Data output (RS232 level)
5	VDD	P	Power input
6	NC		Not connect

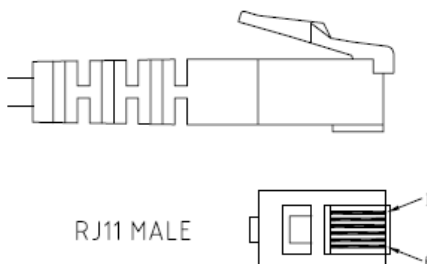

RJ11 MALE

9 DC & Temperature characteristics

9.1 Power consumption (continuous mode)

Parameter	Symbol	Product	Min.	Typ.	Max.	Units
Input voltage	VCC	LS23030-G	4.75	5	5.25	V
		LS23032-G	4	5	6	
		LS23033-G	4	5	6	
		LS23035-G	4	5	6	
		LS23036-G	4	5	6	
Input current	Icc	LS23030-G		45 ⁽¹⁾		mA
		LS23032-G		32 ⁽¹⁾		
		LS23033-G		32 ⁽¹⁾		
		LS23035-G		32 ⁽¹⁾		
		LS23036-G		32 ⁽¹⁾		

Note (1): Measured when position fix (1Hz) is available.

9.2 Temperature characteristics

Parameter	Symbol	Min.	Typ.	Max.	Units
Operating Temperature	Topr	-40	-	85	°C
Storage Temperature	Tstg	-40	25	85	°C

10 Mechanical specification

- **LS23030-G (USB interface)**

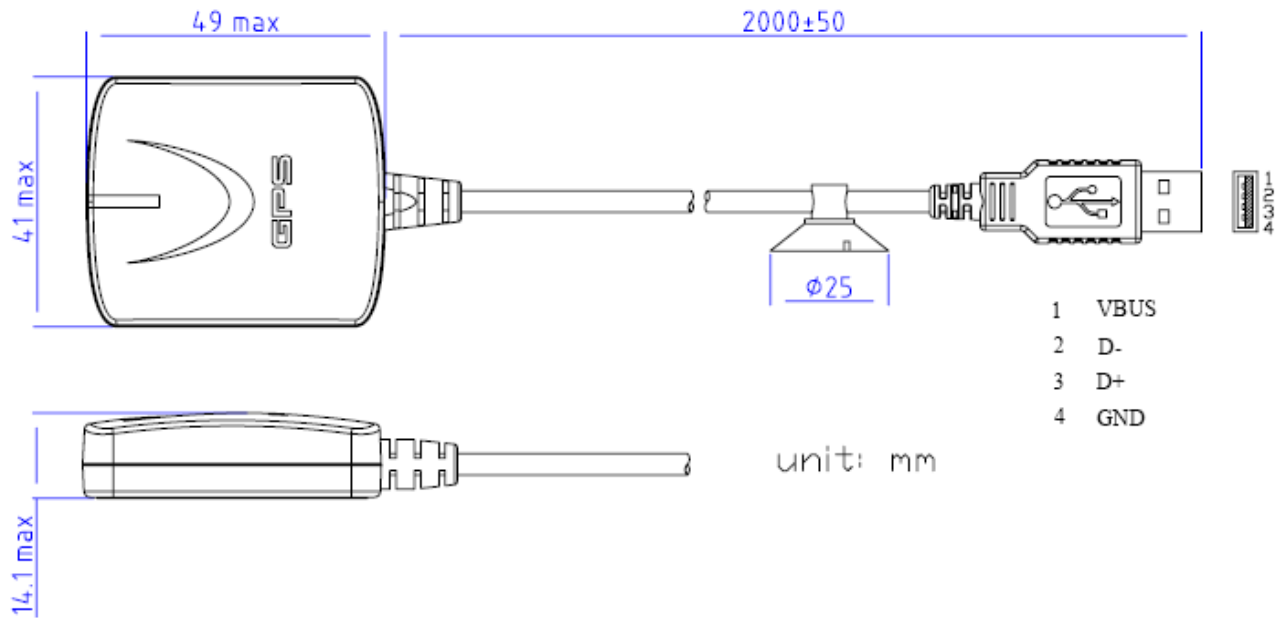

- **LS23032-G (RS232 interface)**

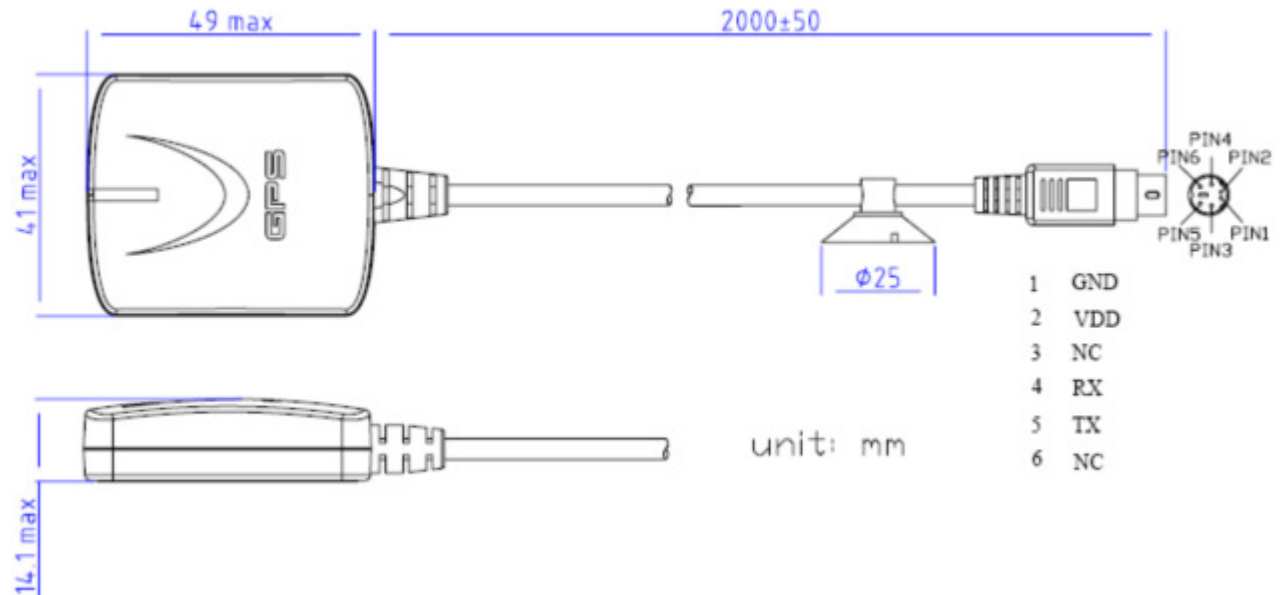

● **LS23033-G (RS232 interface)**

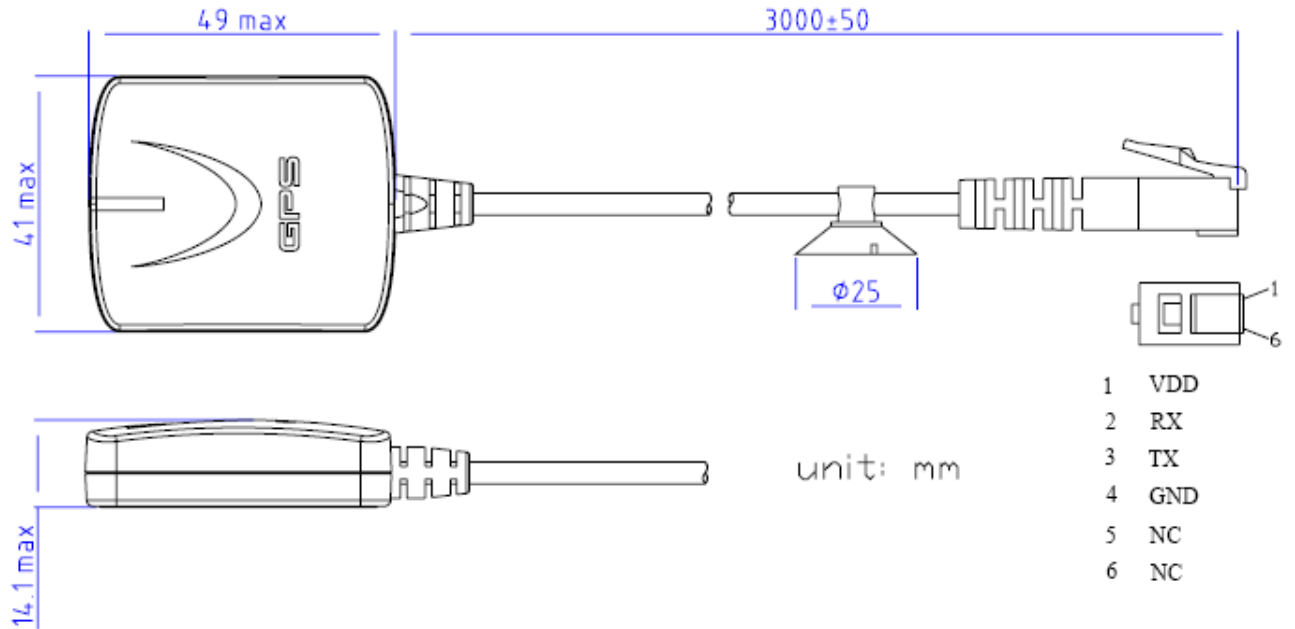

● **LS23035-G (RS232 interface)**

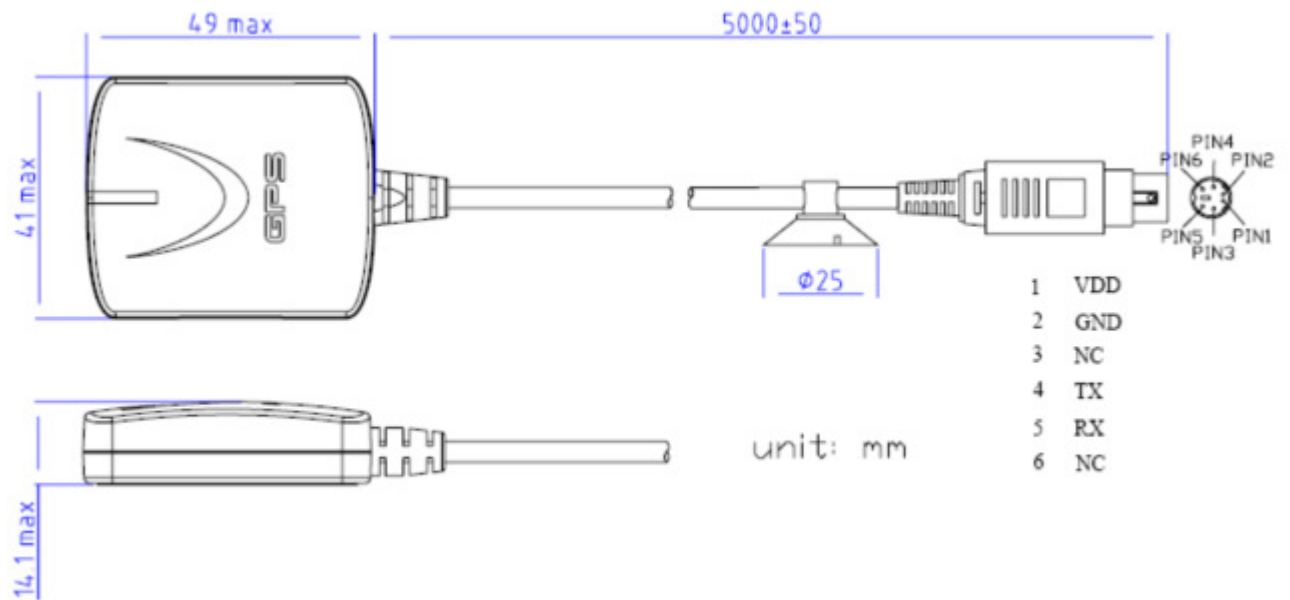

- **LS23036-G (RS232 interface)**

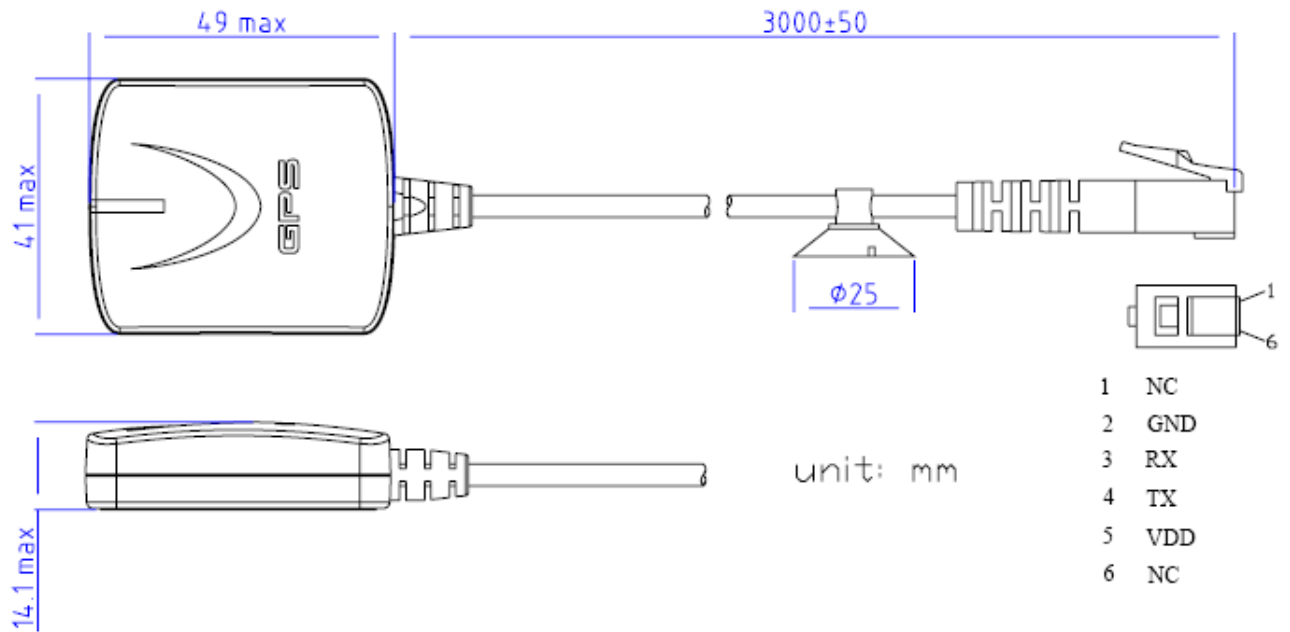

Document change list

Revision 1.0

- First release on March 25, 2013.

Revision 1.0 to Revision 1.1 (October 5, 2018)

- Added alternative cable pictures because the alternative appearance of cable strain relief of connector side has slight differences with original. If customer concerns with this part dimensions, please contact with us in advance.

Revision 1.1 to Revision 1.2 (October 26, 2018)

- Added “PPS over USB” on page 1
- Added 1 PPS over USB for timing application feature in section 2
- Added Linux/Android support feature in section 2
- Added Compatible with GPSD PPS support feature in section 2
- Added High-Quality NTP time server application in section 3
- Added PPS Signal Accuracy specification in section 4
- Added “Note 2” on page 2.
- Added section 6 “How to make sure LS23030-G’s PPS over USB is working in Linux Ubuntu?”

Revision 1.2 to Revision 1.3 (August 23, 2019)

- Removed the skid resistant pad and replaced it with a product label
- Changed the position of magnet from internal to external to improve magnetic force
- Remove the feature of skid resistant pad on the bottom
- Changed internal SMD receiver from MC-1513-G to MC-1612-G
- Changed the typical power consumption of LS23030-G from 34mA to 45mA in section 9.1
- Changed the typical power consumption of LS23032-G, LS23033-G, LS23035-G and LS23036-G from 22mA to 32mA in section 9.1

Revision 1.3 to Revision 1.4 (April 29, 2020)

- Added “Note 1” in the section 4

Revision 1.4 to Revision 1.5 (July 24, 2020)

- Revised protocol support NMEA 0183 version from 4.10 to 4.00 in the section 4.
- Added “Note 3” in the section 4.
- Revised section 5.1 NMEA output message.