

Thoreau

Premium Educational Greenhouse

Assembly Manuals for Models:

12'(w) x **18'**(d) x 9.5'(h)

12'(w) x **24'**(d) x 9.5'(h)



FOUNDATION

IMPORTANT: It is very important to begin with a level surface. Check your foundation to ensure it is level at every point. You must assure your foundation is square and level before beginning assembly.

After choosing a location, proper preparation of the site is essential. The site **must be** level. The **Scholar** greenhouse can be mounted two ways: on concrete slab or concrete footer.

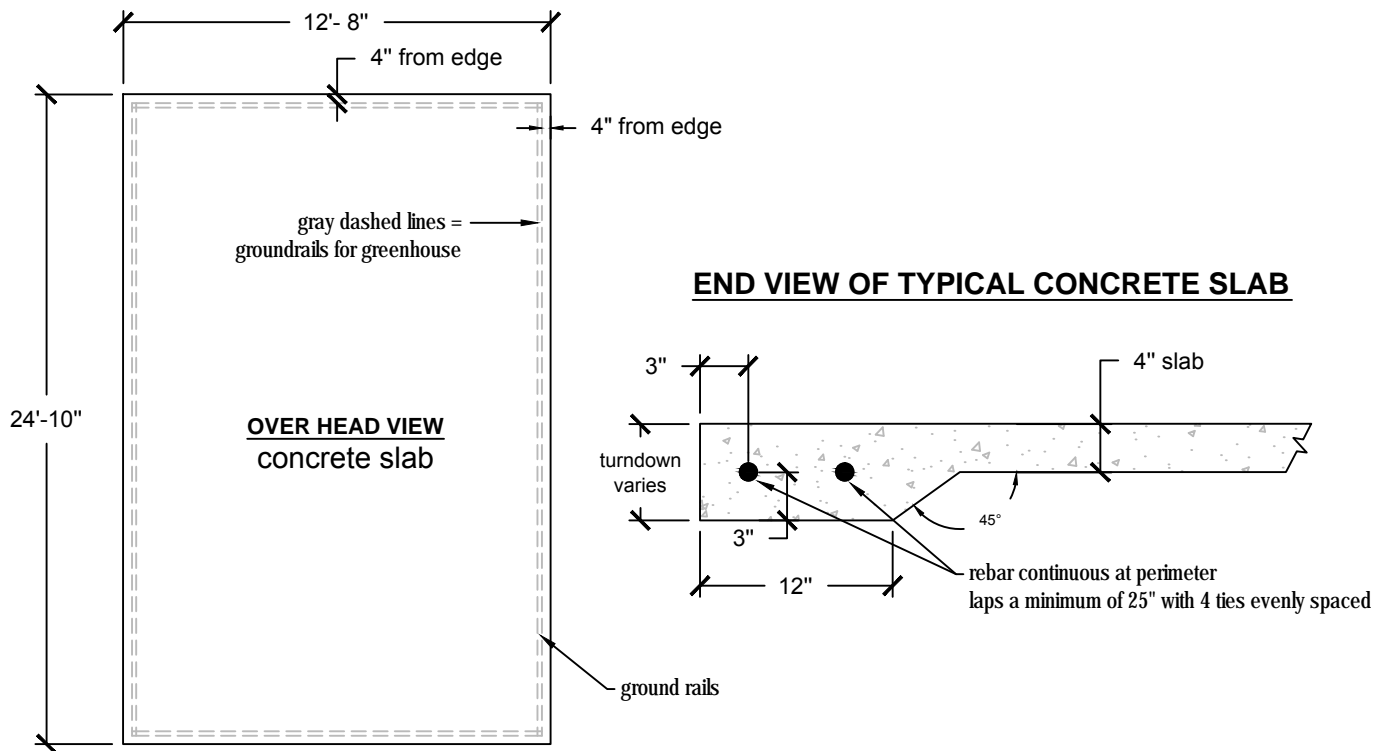

When pouring concrete slab be sure to make the slab **10" longer and 8" wider** than your order size. An example is shown above: **OVERHEAD VIEW concrete slab** shows a greenhouse order for a 12' x 24' Scholar. The slab is poured 12'-8" wide and 24'-10" long. Set front/rear groundrails 4" inward from edge of concrete and side groundrails are set 4" inward from edge of concrete.

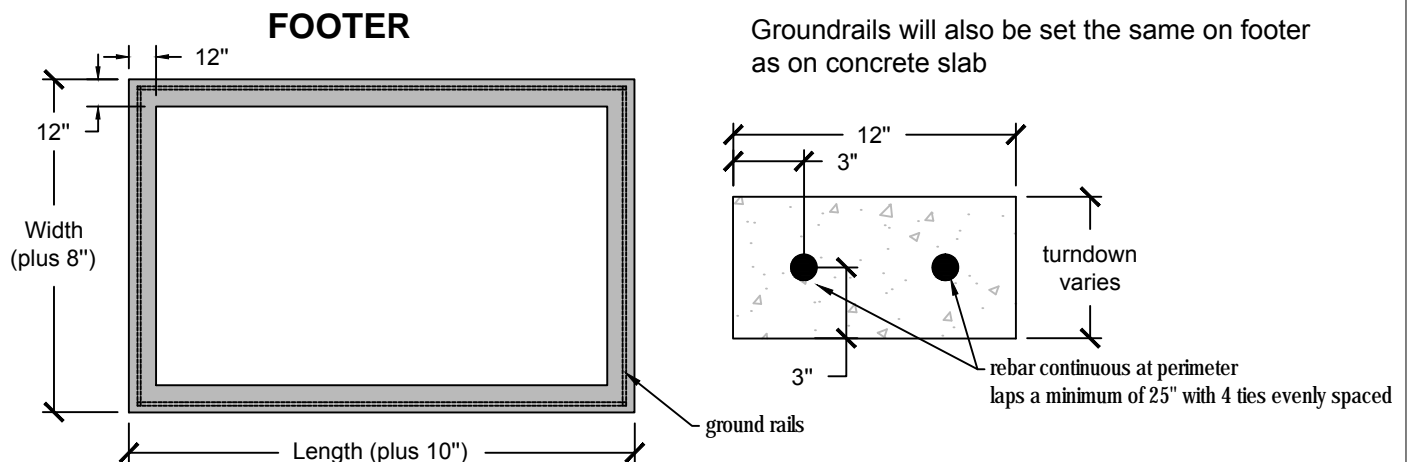

Groundrails will also be set the same on footer as on concrete slab

GROUNDRAIL ASSEMBLY

1. Identify groundrail components: 1 front groundrail, 1 rear groundrail, 2 side groundrails or *side rails*
* front & rear groundrails will be identical in appearance *
2. Locate "L" brackets for groundrails and install them onto the inside of the groundrails at every welded stanchion and 3" to 4" from the corners on the side groundrails. *see below illustration*

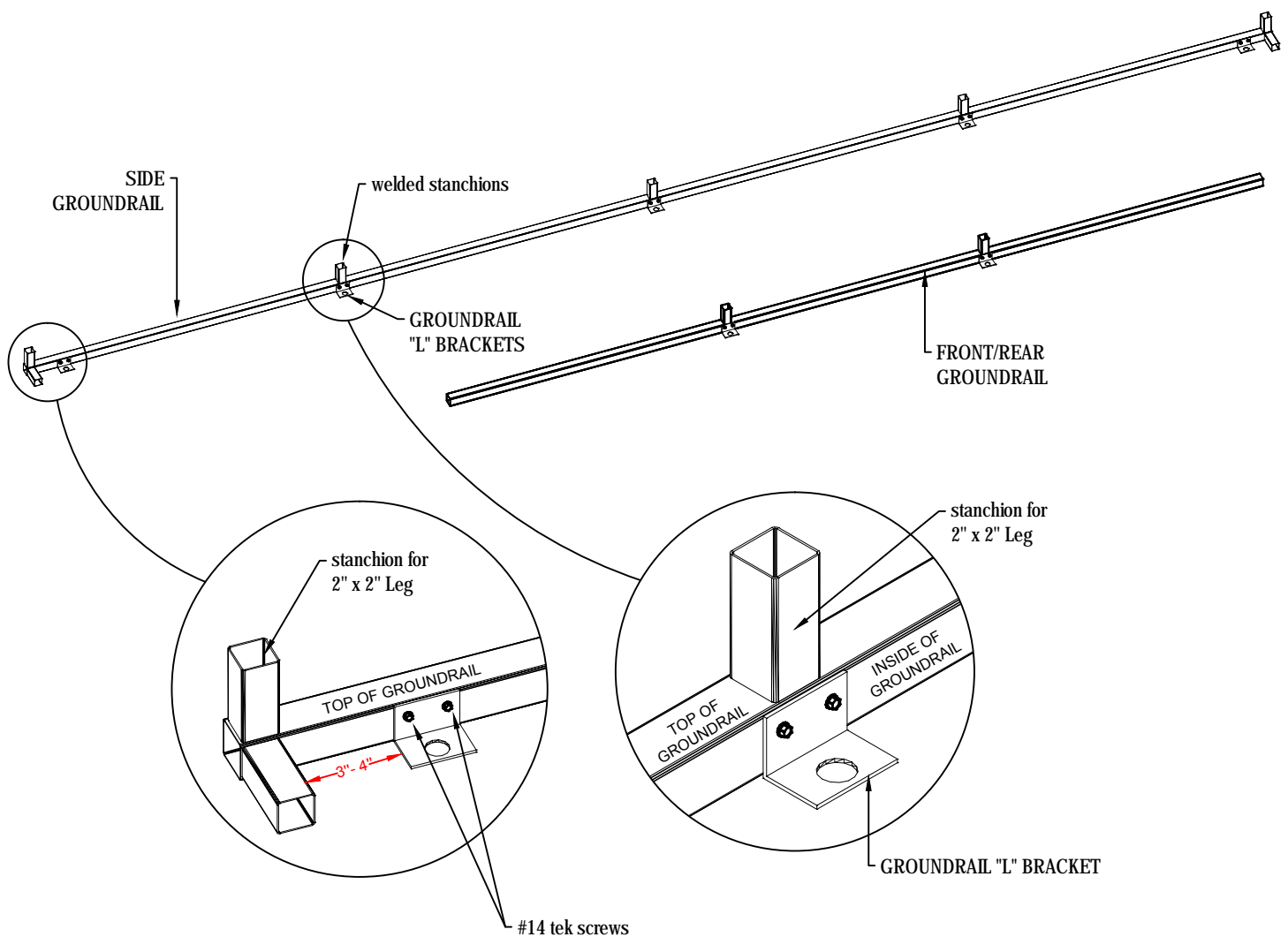

GROUNDRAIL ASSEMBLY CONT'D

3. Connect the front & rear groundrails to the side groundrails, all "L" brackets should be facing toward the inside of your greenhouse. *see Detail A*
*** Make sure groundrails are "square" before securing to foundation***
4. Secure connected groundrails to foundation *see Detail B.*

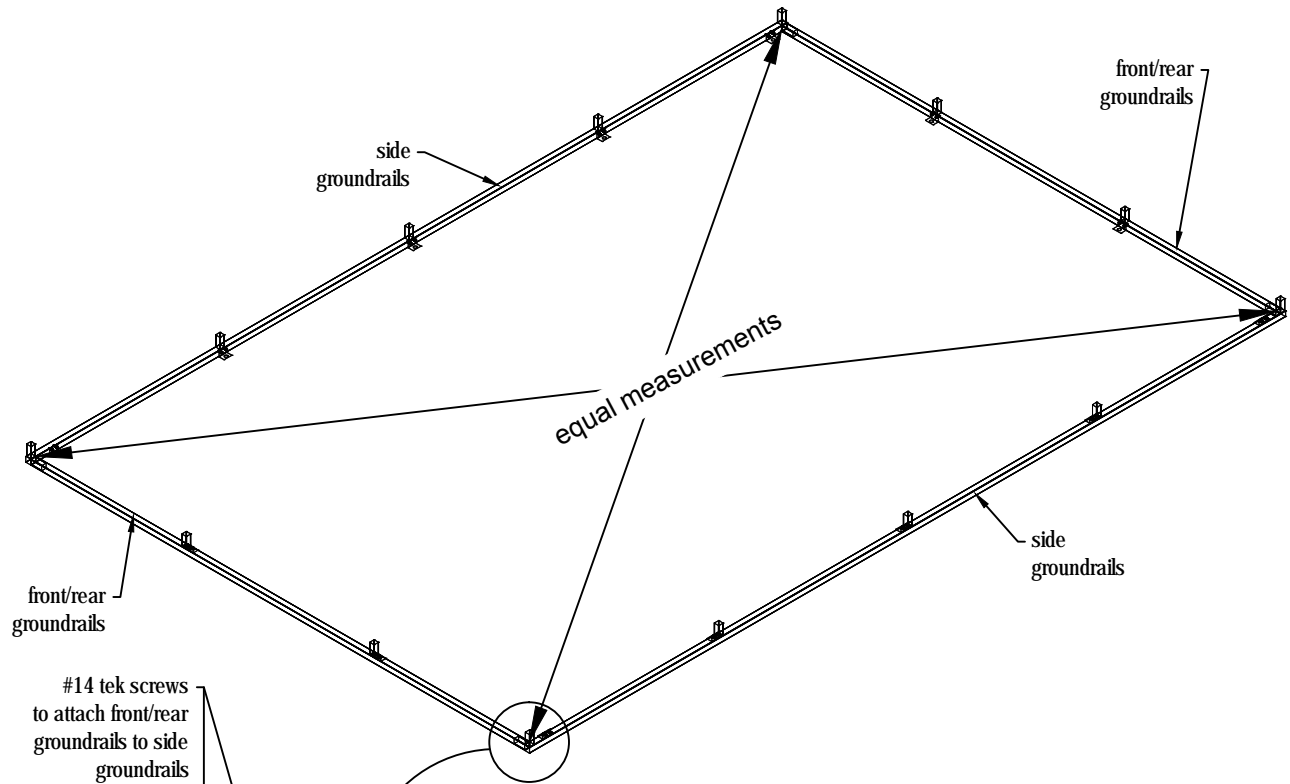

Detail A

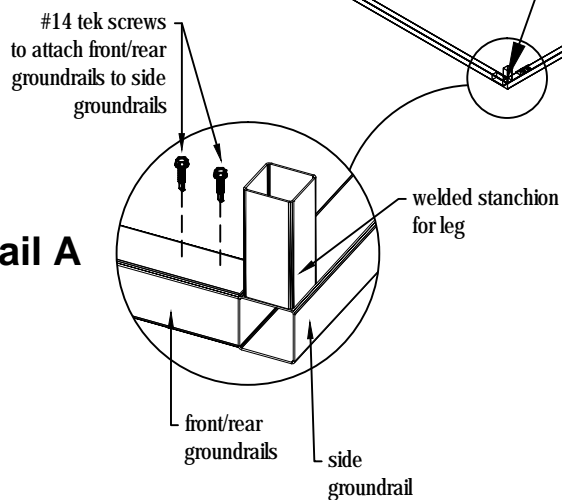

DETAIL B.

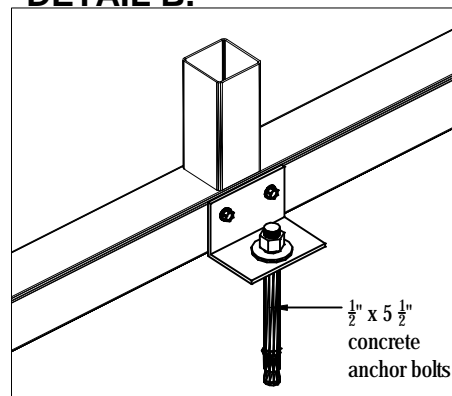

RAFTER ASSEMBLY

1. Identify rafter/bow parts (refer to packing slip for specific quantities of each part)
2. Attach "L" brackets to half bows as shown below for a 12' wide greenhouse.
3. Slide half bows onto center connector and secure with #14 x 1" tek screws.

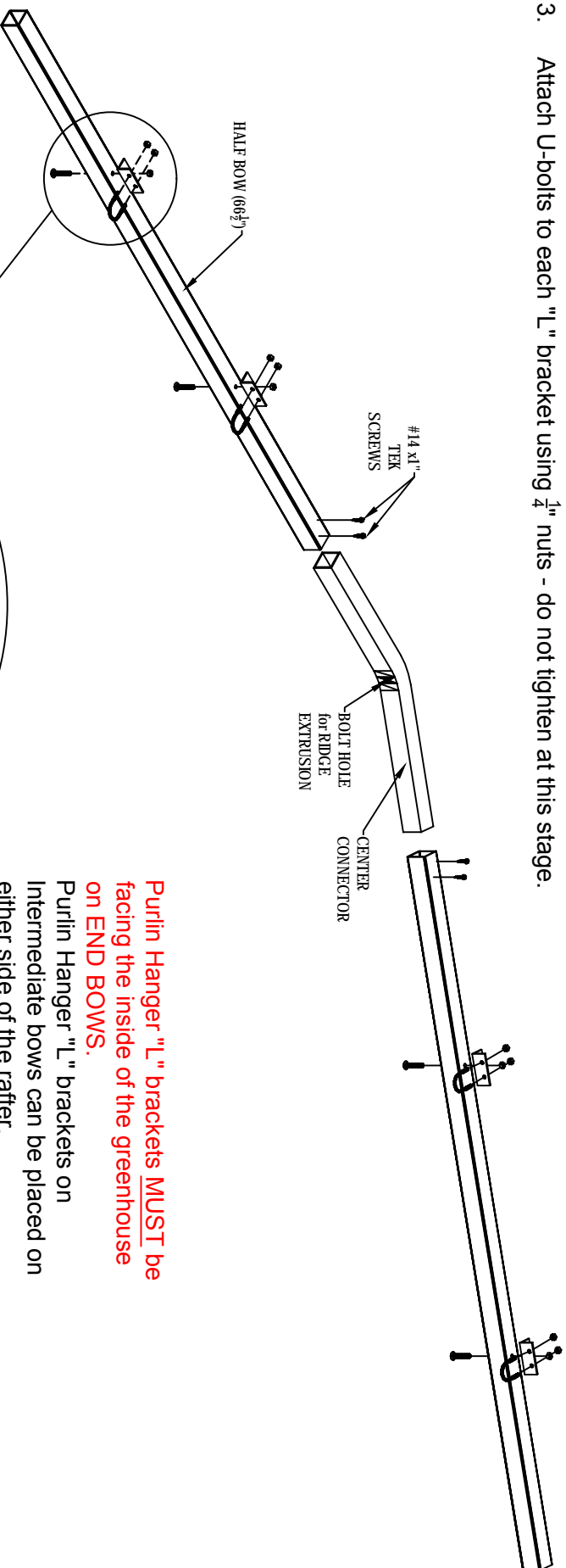

Purlin Hanger "L" brackets MUST be facing the inside of the greenhouse on END BOWS.
 Purlin Hanger "L" brackets on intermediate bows can be placed on either side of the rafter.

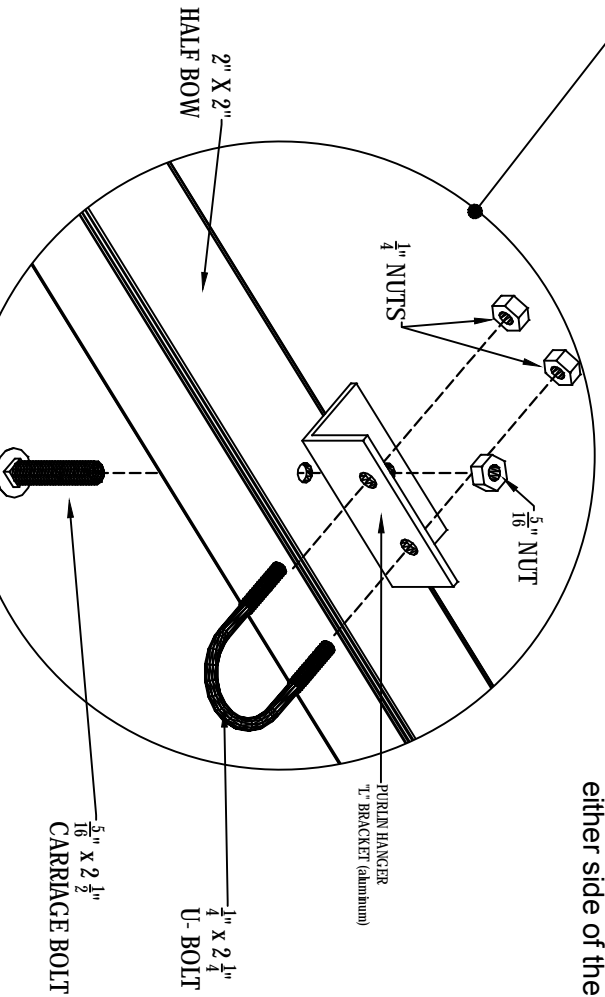

SIDEWALL & ROOF ASSEMBLY

1. Identify legs for sidewalls:
2" x 2" square tubing, *quantity depending on order* (refer to packing slip)

The length of the legs depend on the sidewall height of your order. A sidewall height of 5'-0" will have legs 58" long, so the legs will measure 2" shorter than the ordered sidewall height.

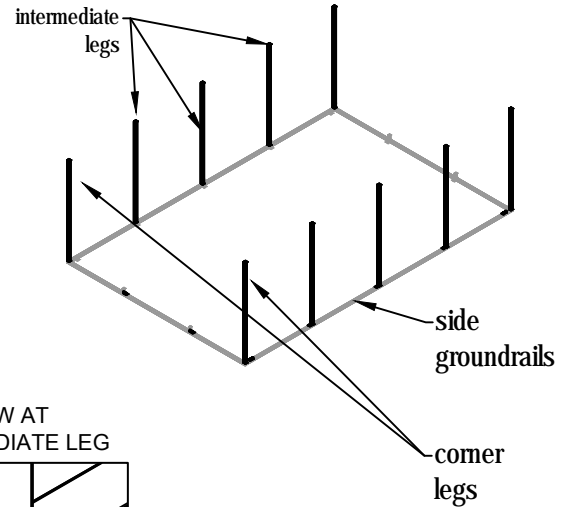

2. Place legs on groundrail stanchions and secure using #14 tek screws

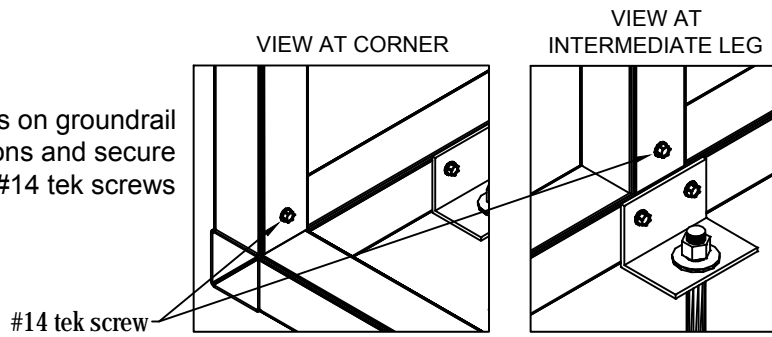

3. After attaching legs to the side groundrails, identify brackets named: Corner Bow to Column Brackets & Intermediate Bow to Column Brackets

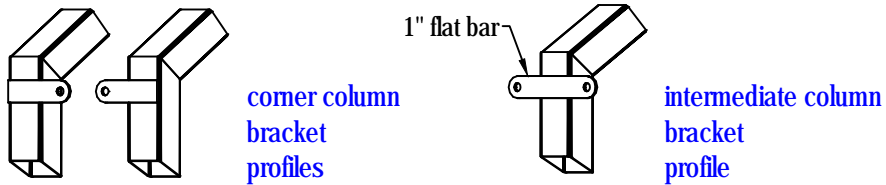

4. Insert the brackets into the top of the legs, let the 1" flat bar rest on the lip of the leg as shown below. Note on the corner brackets, the 1" flat bars have to be facing each other as indicated in corner bracket profiles.
5. Take the assembled rafters and slide them onto the column brackets and secure working from the inside of the greenhouse using #14 tek screws as shown in detail A.

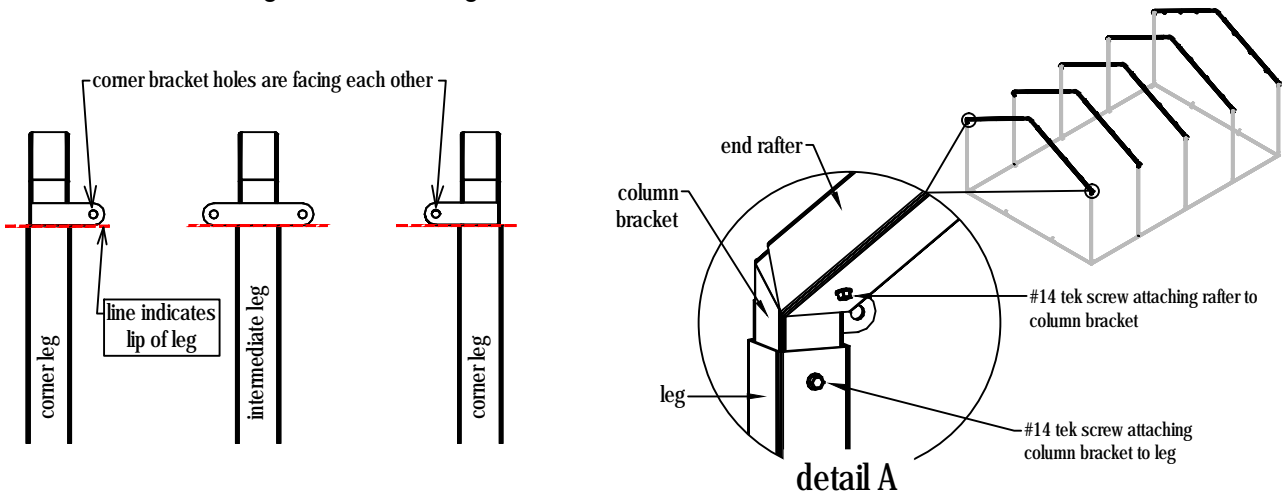

2" X 2" TRUSS CHORD DETAIL FOR SCHOLAR WITH 8' SIDES

1. Identify truss chord (2"x 2" x 11'-8")
2. Attach L brackets flush with the ends of the truss chords **detail A.**
3. With the truss chord L brackets facing down toward the ground, attach truss to the top of the legs **detail B.** Truss chords are to be placed only on the intermediate rafters.
4. Identify truss uprights (1 $\frac{3}{8}$ " x 47")
5. Secure one end of the upright using supplied bolts to the pre-punched holes on the truss chord (2x2).
6. Attach the opposite end of the upright to the rafter, at the pre-punched hole nearest the center connector.

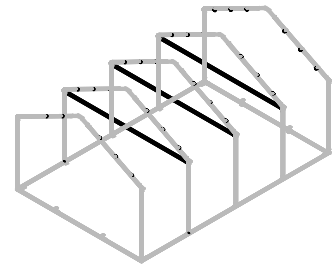

Only Intermediate Legs will have trusses

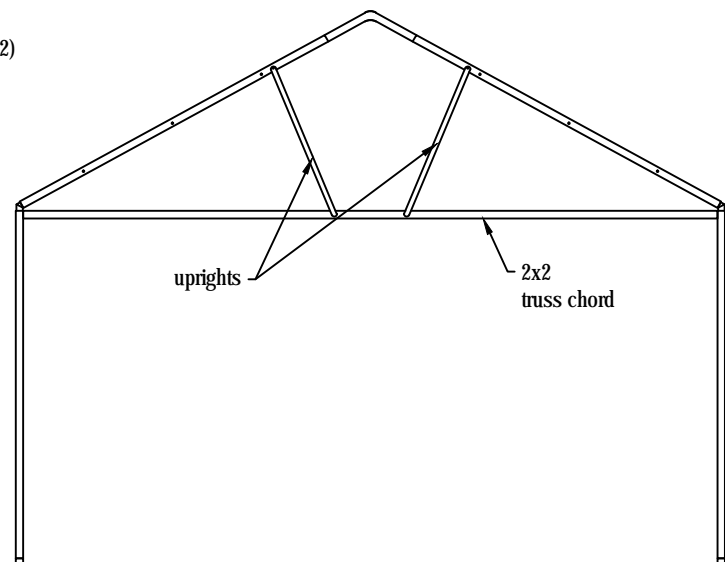
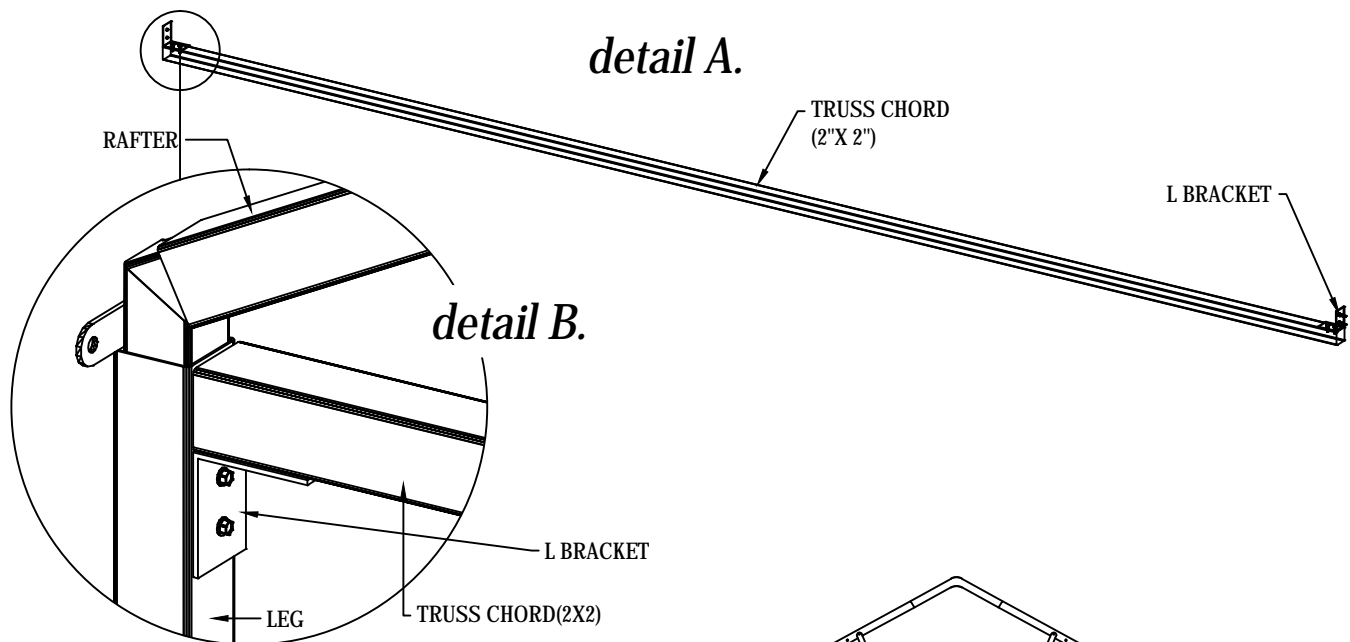

*Completed Intermediate Rafter
w/ Truss & Uprights*

SIDEWALL & ROOF PURLIN

Sidewall Horizontal Purlin (2" x 2" square tubing) will need to be cut into 70" pieces, this should be the distance between each leg.

Before cutting, measure from inside to inside of each leg to make certain that this is your measurement.

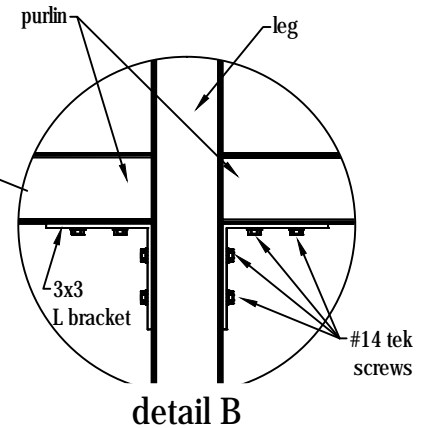
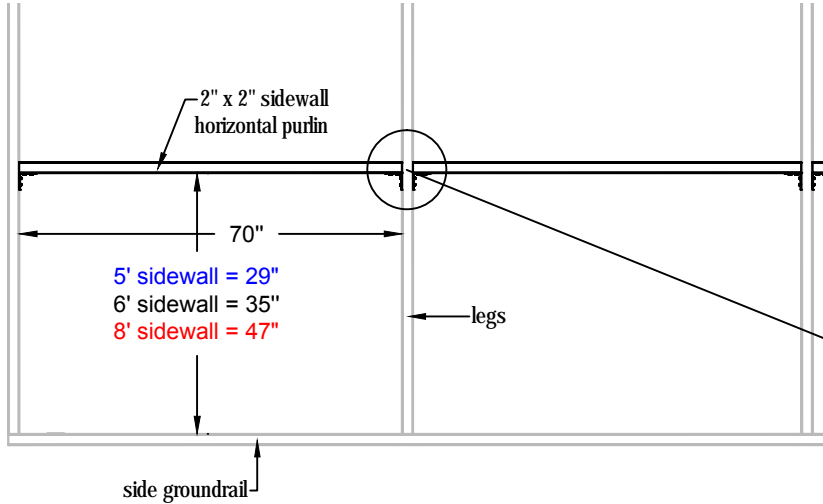
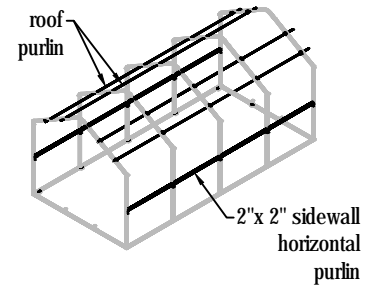

1. Depending on sidewall height ordered, measuring up from the top of the groundrail place purlin at **29" for 5'-0" sides** or **47" for 8'-0" sides**.
2. Attach purlin to legs using 3" x 3" L brackets & #14 tek screws see *detail B*.

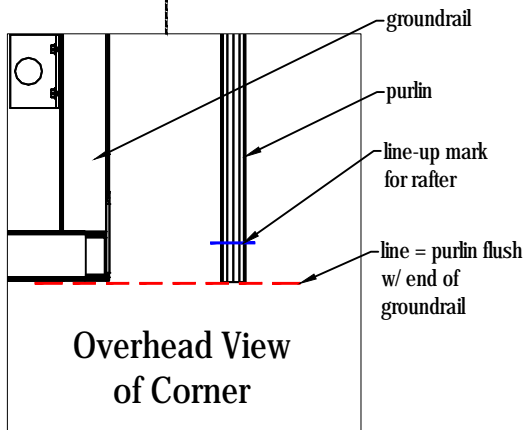
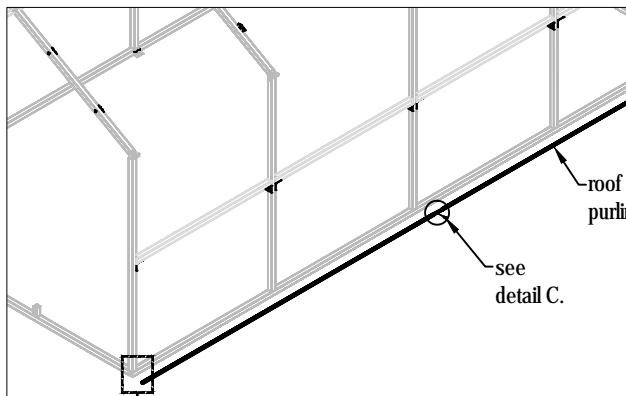

PREPARING of ROOF PURLIN

Identify 1 3/8" x 12'-5" purlin with swedge.

1. connect the appropriate number of purlin together to equal the length of your greenhouse see *detail C*. You may have excess, you will cut it off at a later time.
2. Next, lay the connected purlin, on the ground flush with the end of the side groundrail see *overhead view of corner*.
3. Make a mark 2" from the end - this represents the width of the leg on the purlin. Then move down and mark one side of the intermediate leg (on the purlin) and then the other side of the leg (on the purlin)
4. Repeat this process for the length of the structure and all runs of purlin.

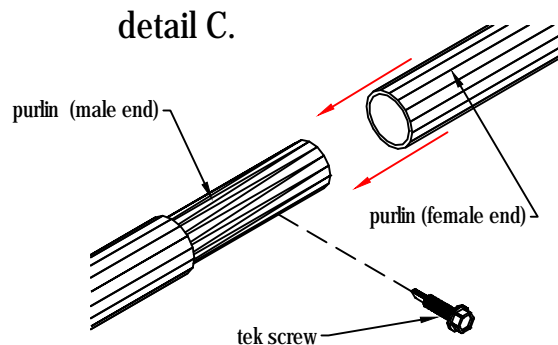

ROOF PURLIN CONT'D

When installing roof purlin start from the front or rear and slide the purlin through the U-bolts on the purlin hanger "L" brackets that are already attached to the rafters.

5. Flush one end of the purlin with the End Rafter (front or rear) using the marks that you made on the purlin, line up the back side of the rafter and tighten u-bolt on to the purlin.
6. Move to the next rafter, using the marks on the purlin, line up the rafter and tighten u-bolt onto purlin.
7. Repeat this process for the remaining runs of purlin. Individually tightening u-bolts as you go and keeping the 70" distance between each rafter
8. Cut off any excess roof purlin flush with end rafter

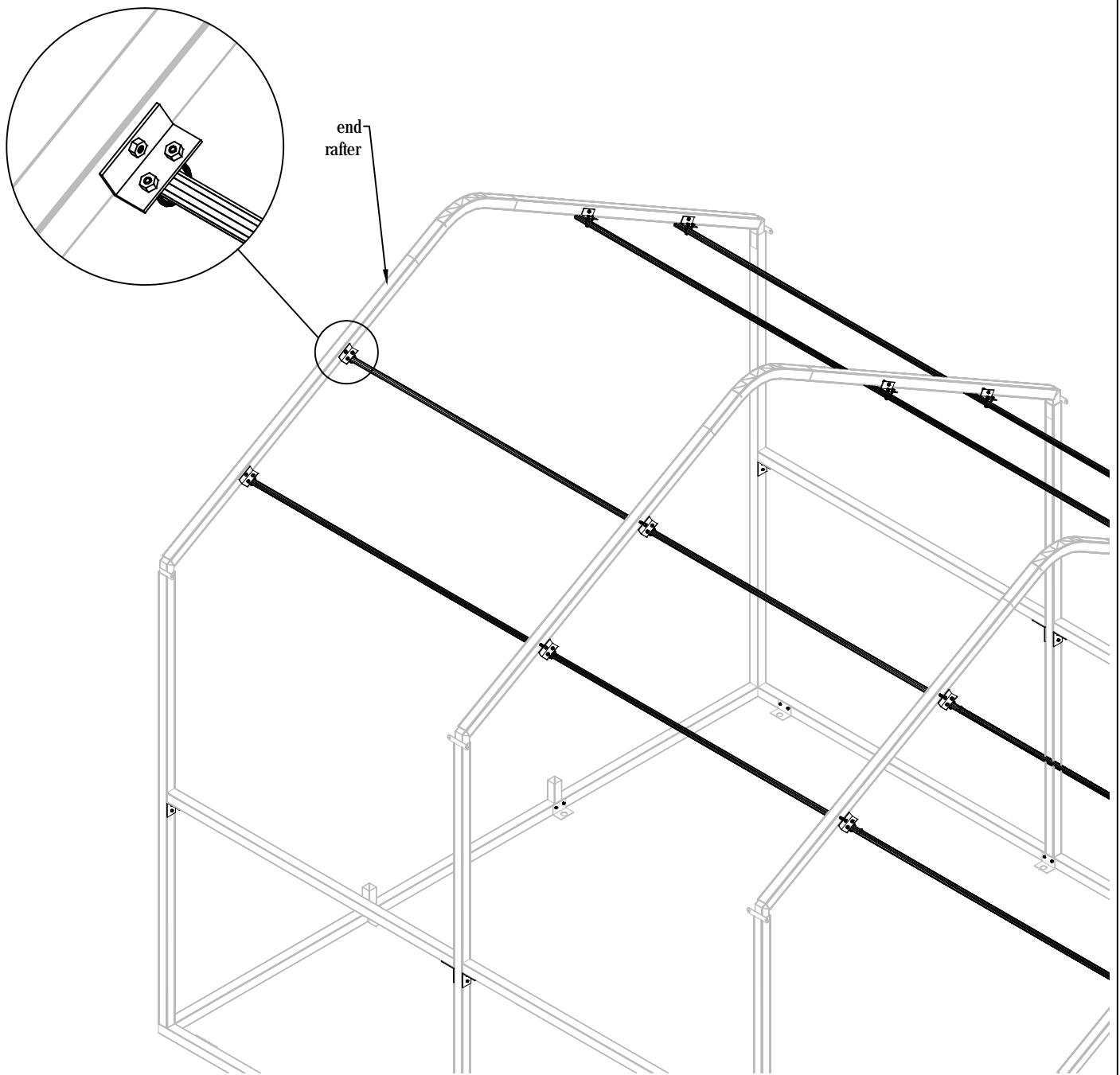
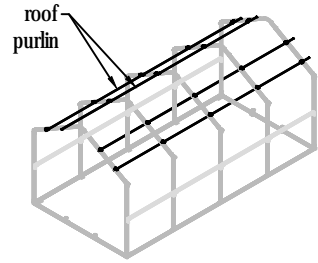

INSTALLING EAVE EXTRUSION

Eave extrusion is an aluminum channel that receives both the roof and sidewall polycarbonate sheets.

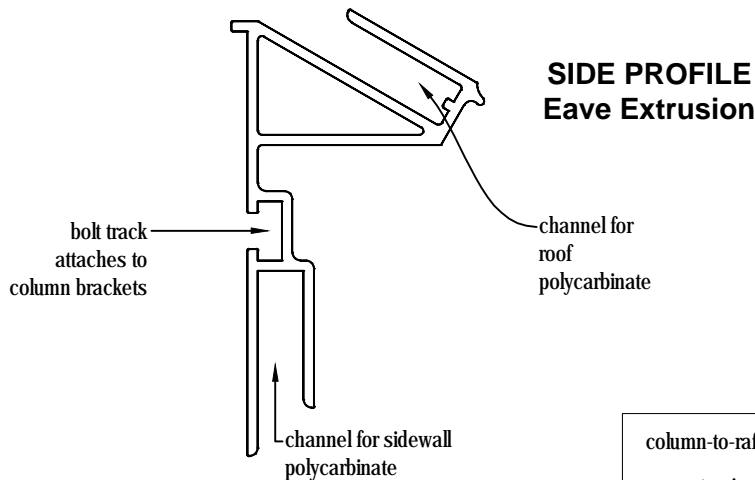
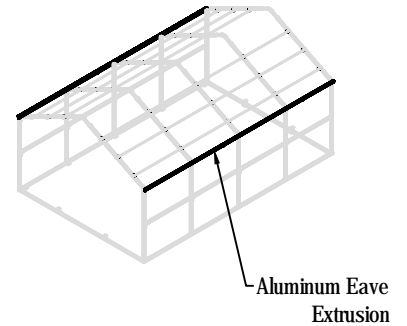

1. Identify Eave Extrusion.
2. Slide 1/4" x 3/4" stainless steel bolts into the bolt track, for proper bolt quantity, count the holes in the bow-to-column brackets.
3. Flush eave extrusion with end of the corner leg
4. Align the bolts with the holes in column-to-rafter brackets and apply 1/4" stainless steel nuts
5. To splice two pieces of Eave Extrusion, use 2" x 6" aluminum splice plates. At the end of the first piece of Eave Ext. add two 1/4" x 3/4" bolts also add two bolts at the start of the second piece.
6. Apply aluminum splice plate and secure with 1/4" nuts. Repeat process for opposite side.

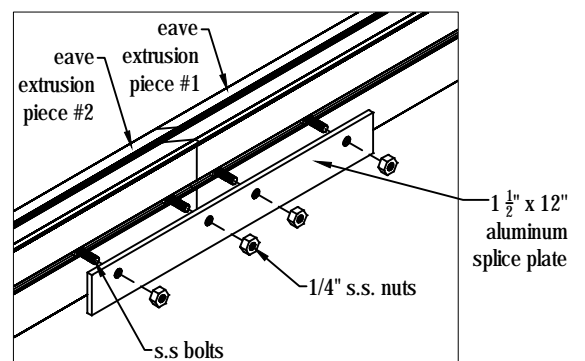
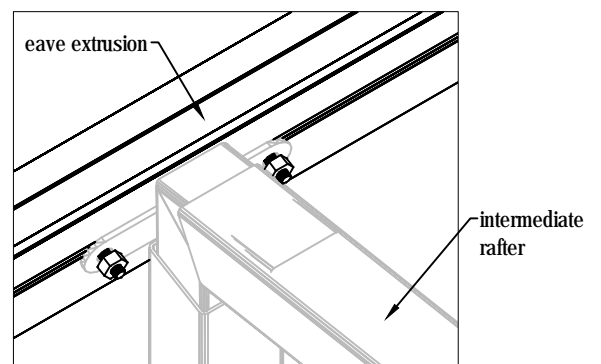
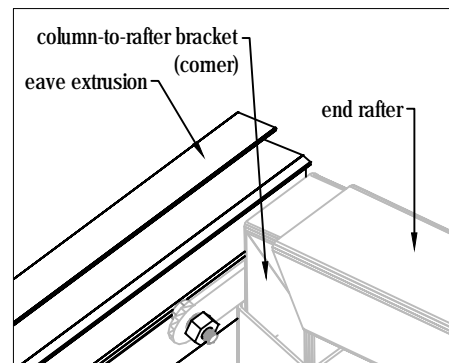

FRAMING ENDWALLS

Endwall studs will be pre-cut. Door headers, Door studs and horizontal purlin will have to be field cut.

Refer to the page(s) labeled Endwall Layouts for proper placement and measurements of your purlin & door studs.

The illustrations below show connection details for attaching door studs to the groundrail and rafter, also the proper placement of "L" brackets when framing an opening for a door or fan.

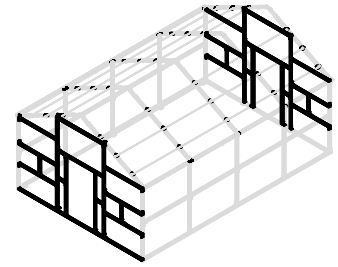

FRONT ENDWALL

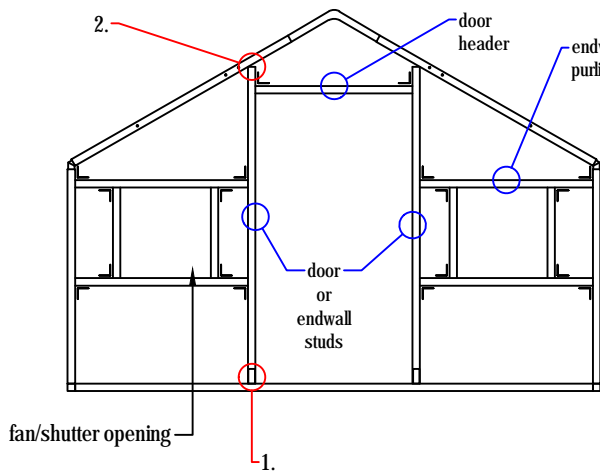

REAR ENDWALL

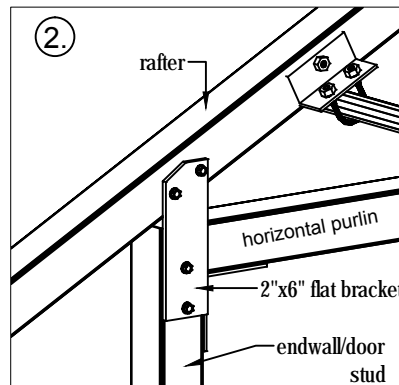
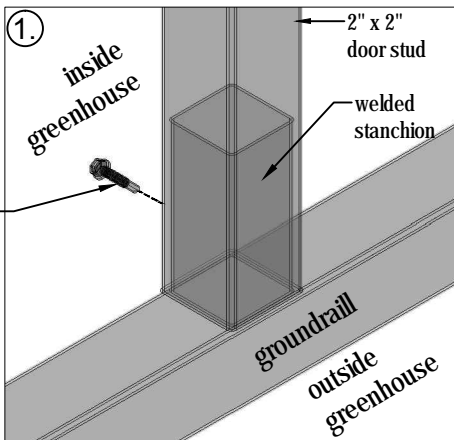
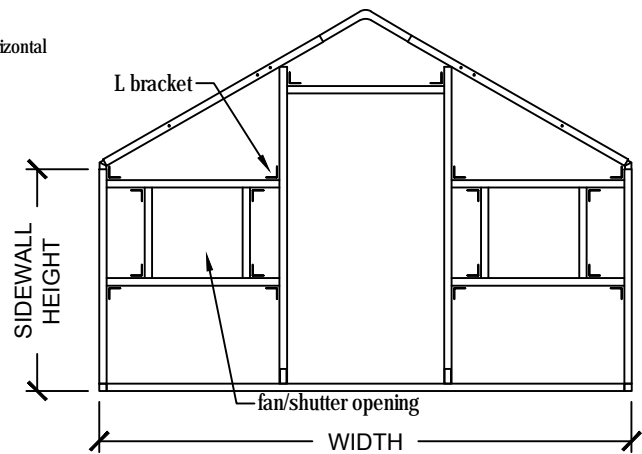

1. install front/rear door studs over the welded stanchions and secure using #14 tek screws

2. view from inside and at the end rafter. Connect the endwall studs to the rafters using 2x6 flat bracket and #14 tek screws

IF YOUR GREENHOUSE HAS AN EVAPORATIVE COOLING SYSTEM
refer to the Endwall Layout (rear endwall w/ evaporative cooling system) page

In the next page(s) you will see **typical** Endwall Layouts for the "**Scholar Series**" greenhouse. Look these drawings over carefully, if you do not have a typical endwall layout you will receive a special drawing separate from the instruction manual with your endwall configuration.

Frame out measurements are provided for equipment - fans, shutters and doors that Atlas Manufacturing offer. We recommend identifying your specific equipment sizes before starting the process of framing the endwalls.

Some endwall layouts will show framing out for Evaporative Cooling Systems. This is for endwall framing only, actual step by step instructions are in (2) separate booklets.

ENDWALL LAYOUTS (FRONT ENDWALLS)

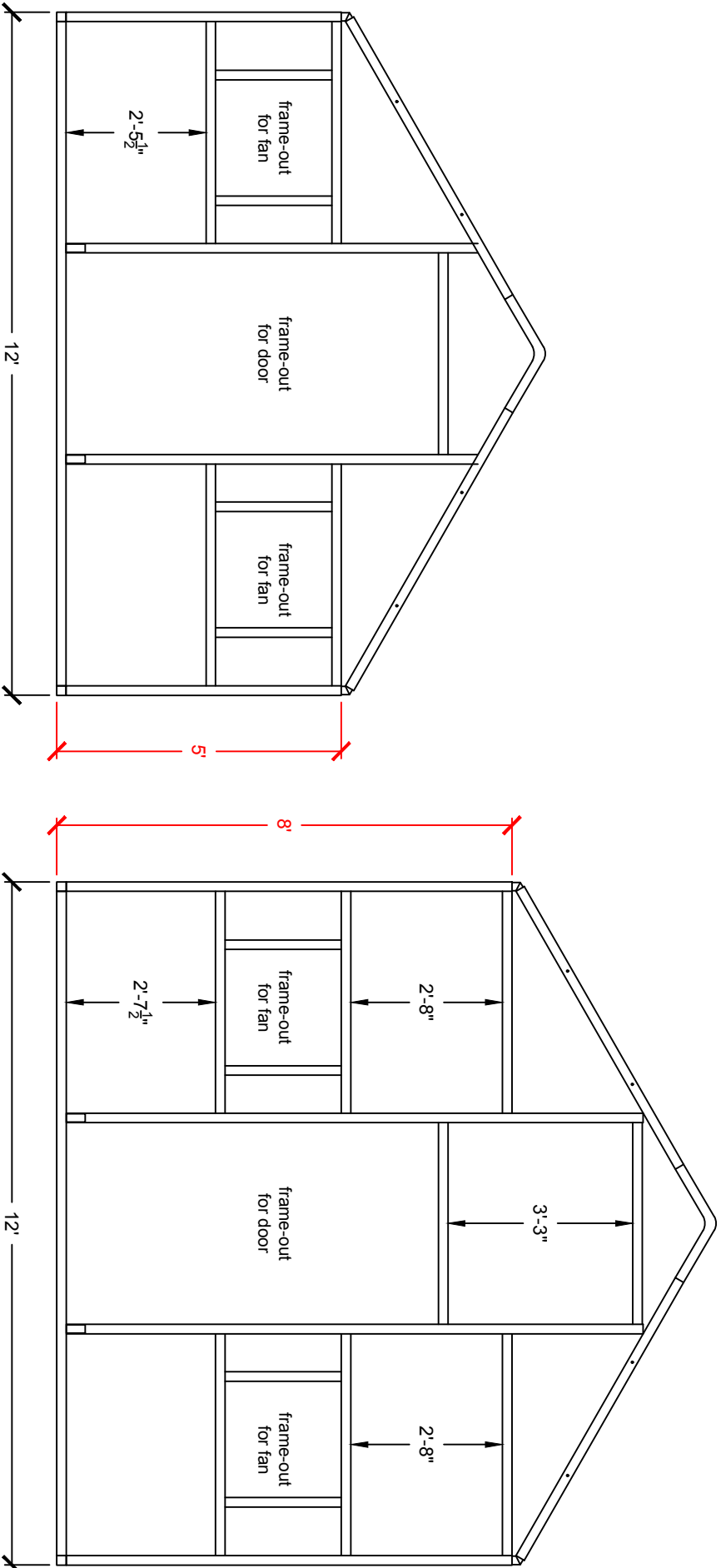

If you have another door and shutters your Rear Endwall Layout will be the same as shown here.

[see OPENING MEASUREMENT for FANS, SHUTTERS and DOORS](#)
[page for equipment openings](#)

ENDWALL LAYOUTS (REAR ENDWALLS)

- ALL FRAMING MATERIAL = 2" x 2" SQUARE TUBING
 - REFER TO "OPENING MEASUREMENTS FOR FANS, SHUTTERS AND DOORS"
 - PAGE" FOR EQUIPMENT FRAME-OUT SIZES

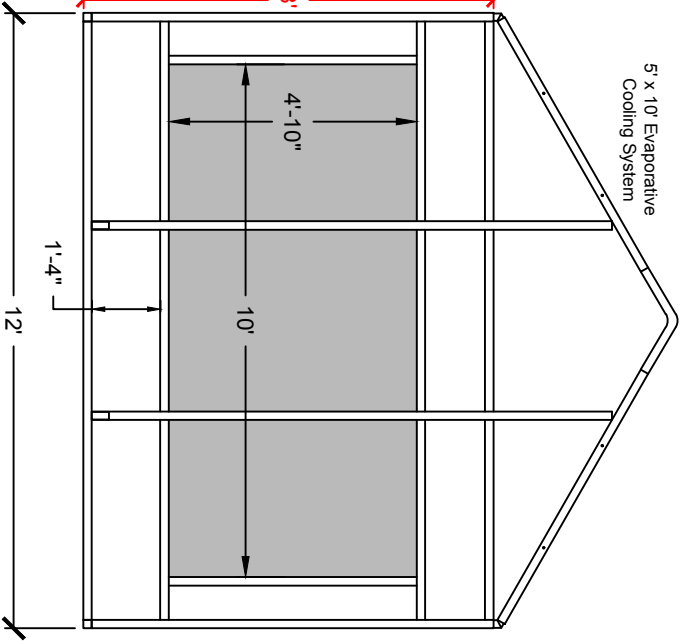
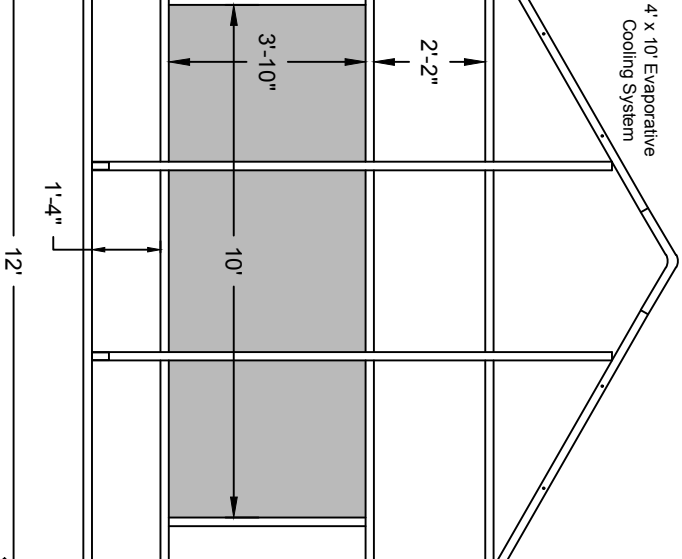
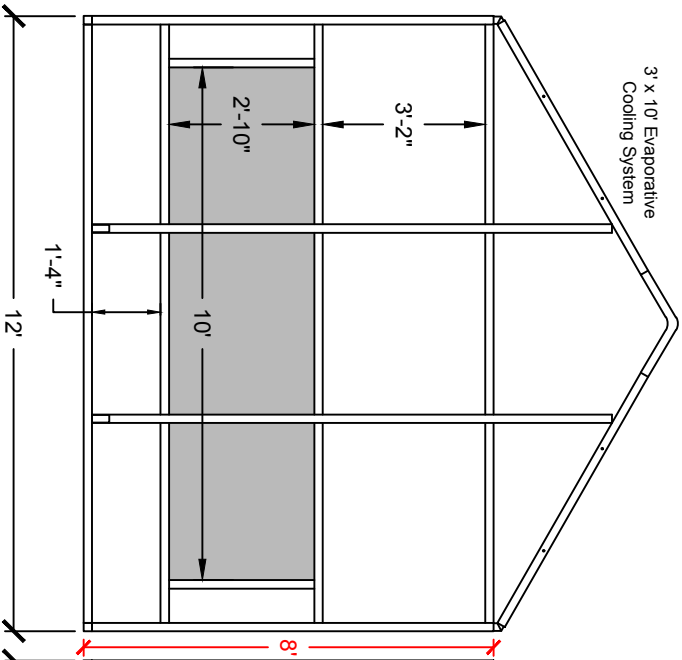
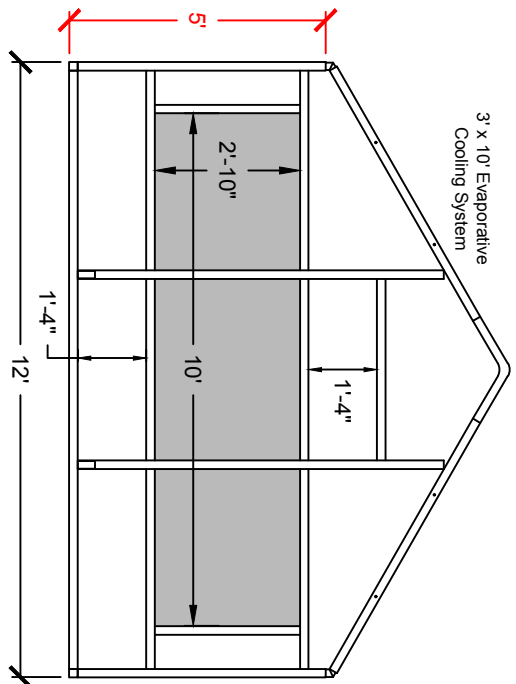
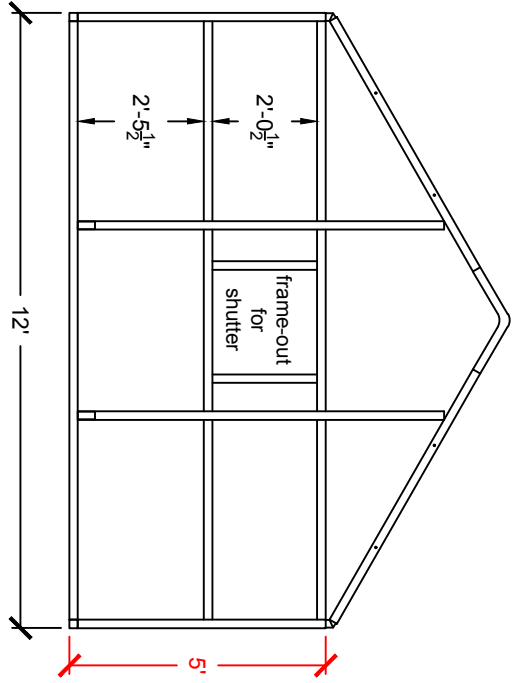

SIDEWALL DOOR MOUNTING

If your Scholar has 8' sides and an Evaporative Cooling System in the endwall, you will need to mount the rear door in the sidewall of the greenhouse **as seen below**.

SIDE VIEW OF GREENHOUSE

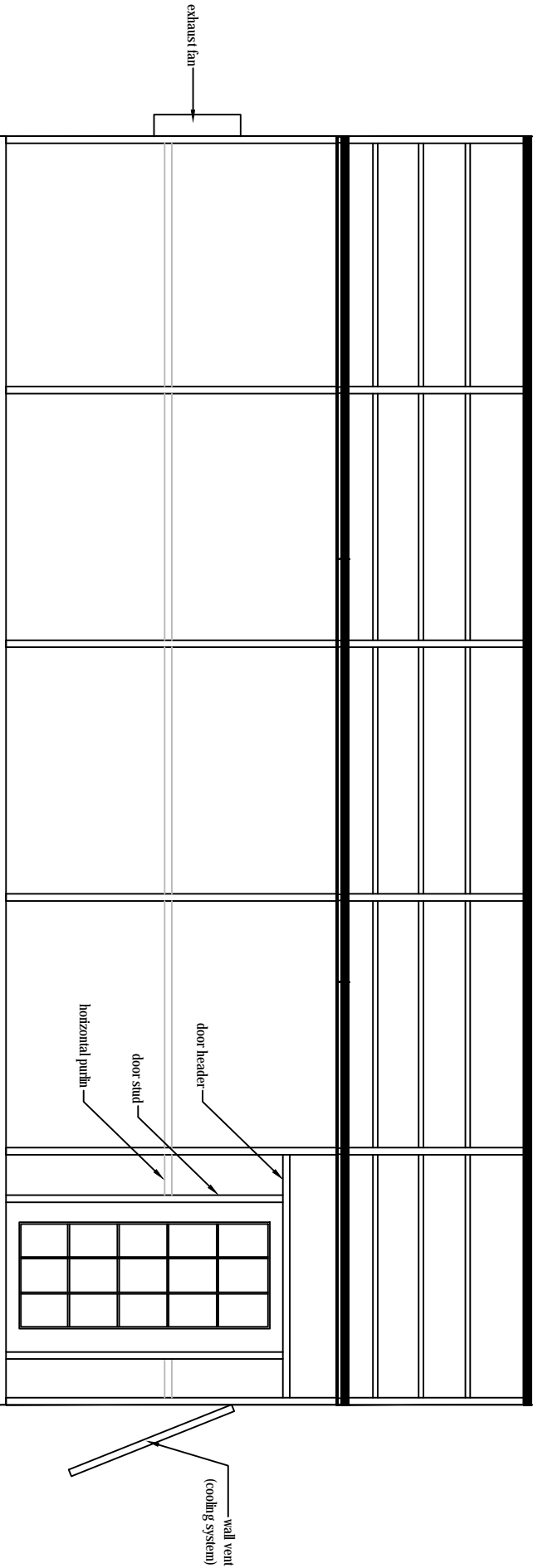

Refer back to Framing Endwalls page for door framing instructions.

OPENING MEASUREMENTS FOR FANS, SHUTTERS AND DOORS
{SUPPLIED BY ATLAS}

Fan opening for:

18" Box wall "Quietaire"	24 1/2" High X 24 1/2" Wide
30" Slant wall "Quietaire"	35 5/8" High X 34 3/4" Wide
36" Box wall "Quietaire"	40 1/2" High X 40 1/2" Wide
36" Slant wall "Quietaire"	42 1/4" High X 41" Wide
42" Slant wall "Quietaire"	48 1/2" High X 47" Wide
48" Slant wall "Quietaire"	54 1/4" High X 52 3/4" Wide
56" Slant wall "Quietaire"	65" High X 63" Wide

Shutter openings for:

24" Shutter	24 1/2" Square
30" Shutter	30 1/2" Square
39" Shutter	39 1/2" Square
45" Shutter	45 1/2" Square
48" Shutter	48 1/2" Square
60" Shutter	60 1/2" Square

Door openings for:

42" X 6'6" Swing door	Set openings 42 1/2" Wide X 78 1/2" High
4' X 6'8" Swing Door	Set openings 48 1/2" Wide X 80" High
36" X 6'8" Swing door	Set openings 36" Wide X 80" High
6' X 6'8" French Door	Set openings 72" Wide X 80" High
4' X 7' Single Sliding door	Set openings 46" Wide X 82" High
8' X 7' Double slide door	Set openings 96" Wide X 82" High

NOTE: Measurements are inside to inside.

If you have purchased an evaporative cooling system, please refer to those instructions now for frame openings and end wall layouts.

All of the above listed items may not be available for your particular structure.

INSTALLING HEATER HANGER

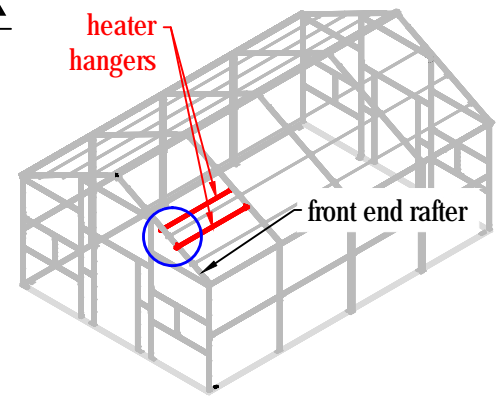

HEATER HANGERS MUST BE INSTALLED BEFORE COVERING END WALLS

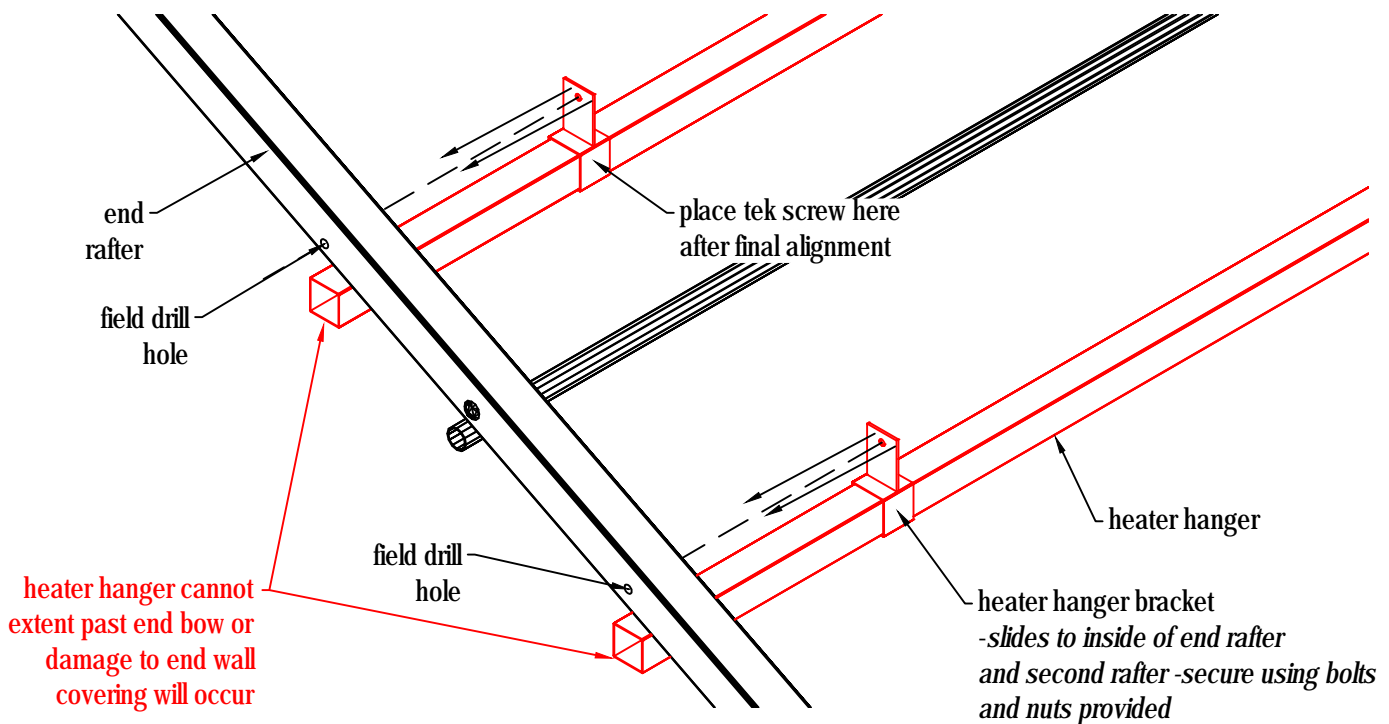

Attach the heater hangers to the end rafter (preferably to the front end rafter) and the second rafter. Be sure that the heater hanger does not extend past the end rafter because it will damage the end wall covering when it is installed.

Bolt holes for the heater hanger brackets are to be field drilled into the rafters. **IMPORTANT: insert the bolts from the outside of the greenhouse. *If inserted from the inside, it damage end wall covering.***

After you are comfortable with the placement of the heater hangers, secure the heater hanger brackets to the heater hangers using a tek screw. This step will insure that the heater hanger will not slide out of place when hanging your heater.

VENT PIPE KIT FOR NON-POWER VENTED HEATERS

PARTS GENERALLY REQUIRED

- 1- ADAPTER FOR DOUBLE WALL PIPE
- 2- WALL COLLARS
- 1- ADJUSTABLE ELBOW
- 1- VENT STACK
- LOT- PCS. DOUBLE WALL PIPE
- 10'- METAL STRAPPING (WALL BANDS)

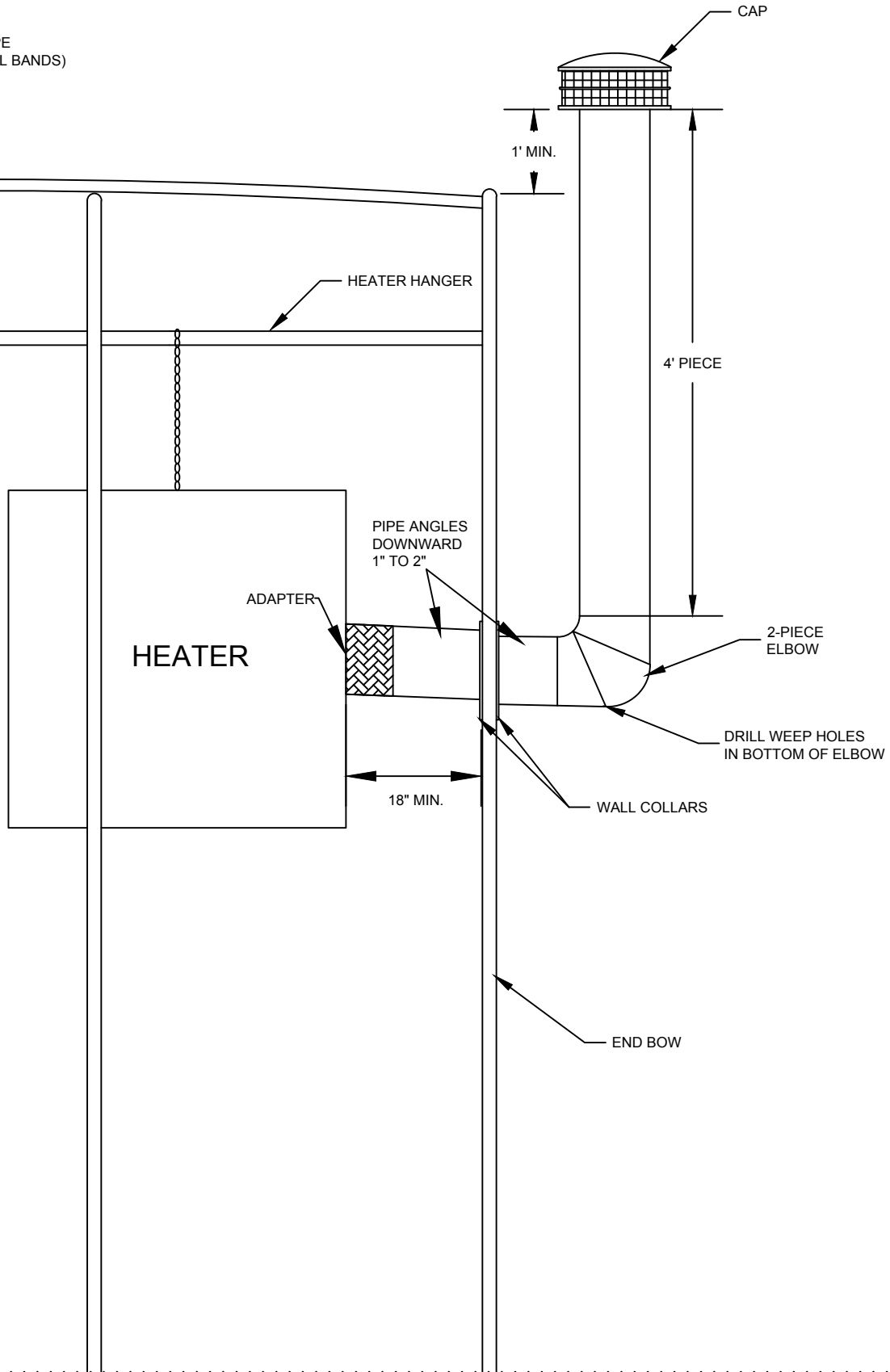

HEATER VENT PIPE FOR A POWER VENT HEATER

PARTS GENERALLY REQUIRED

- 2- WALL COLLARS
- 2- ADJUSTABLE ELBOW
- 1- VENT STACK
- 2- 1'PCS. DOUBLE WALL PIPE

With a power vent heater it is not necessary for the vent stack to be above the roofline.

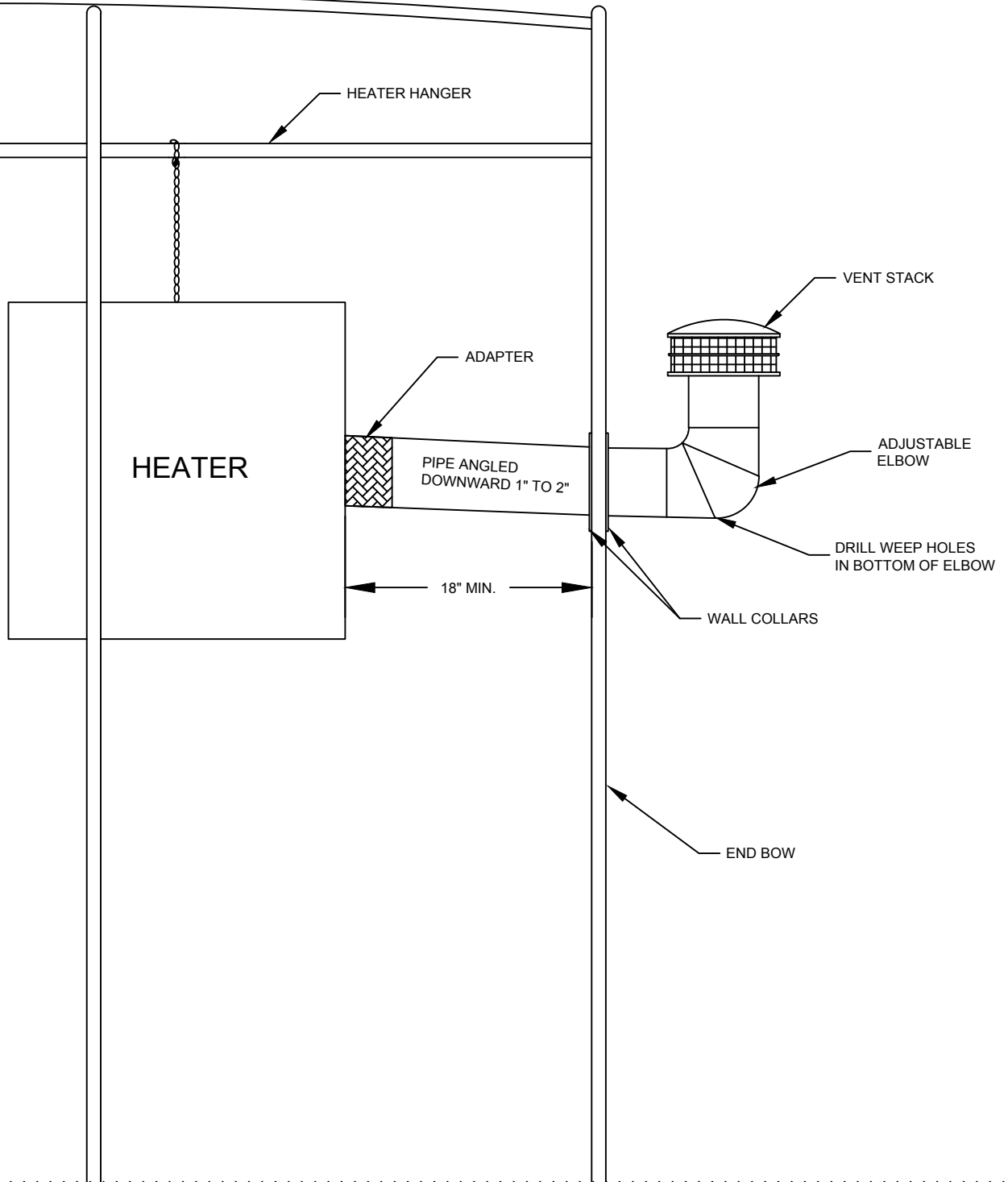

ALUMINUM BASE ANGLE

1. Identify the 2"x 3" Aluminum Base Angle (ABA).
2. Place ABA against the side groundrails (3" down 2" up)

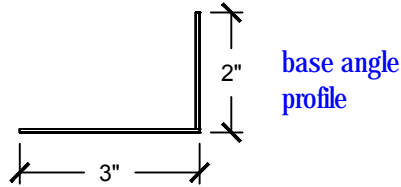
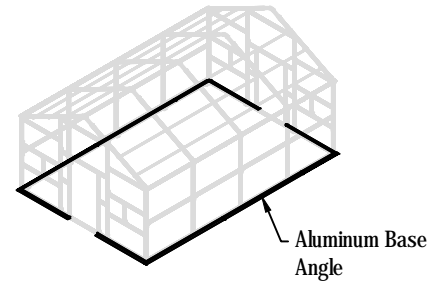

3. Slide the ABA past the end of the groundrail 3". Mark on the 2" side of the angle where the groundrail ends and cut 2" side on the line. The 2" side of the ABA will be flush with the groundrail, and the 3" side will hang past the groundrail 3".

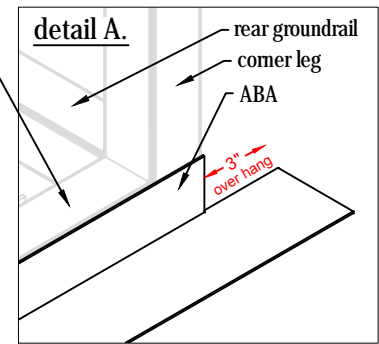
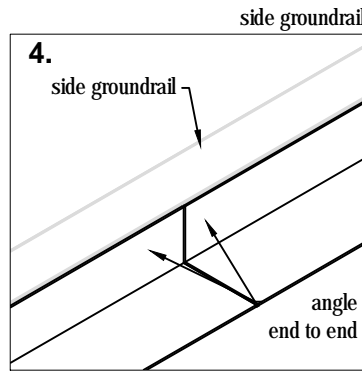
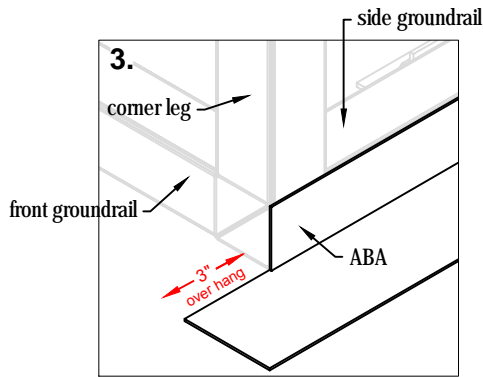
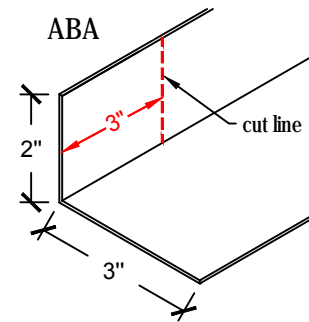

4. After notching the initial piece of ABA, continue placing angle end to end down the side groundrail. Repeat notching process at opposite end of greenhouse. ***Remember* when cutting ABA at opposite end of greenhouse, DO NOT cut the ABA flush with groundrail. Cut 3" longer than groundrail and notch the 2" side back 3" see detail A.**
5. Lay ABA across the front & rear of the greenhouse. Place a piece of ABA against the 3" overhang at the corner of greenhouse. Make sure that the ABA is held against the front groundrail, mark the ABA at the door stud and cut off flush with the inside edge of door stud see 5a. Repeat for opposite side of door and rear of greenhouse. *If you do not have a door in the rear of greenhouse, lay ABA end to end to equal the width of the greenhouse.*

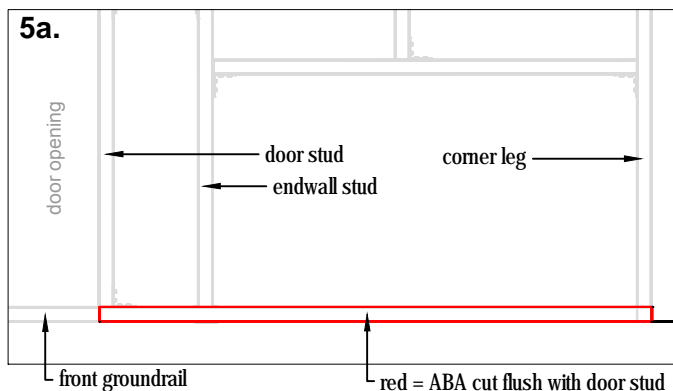
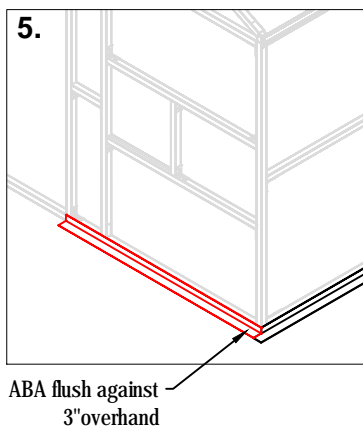



Using a metal cut bit, drill a 5/16" hole approximately every 18" apart down the length of the ABA. (**Photo 1**)

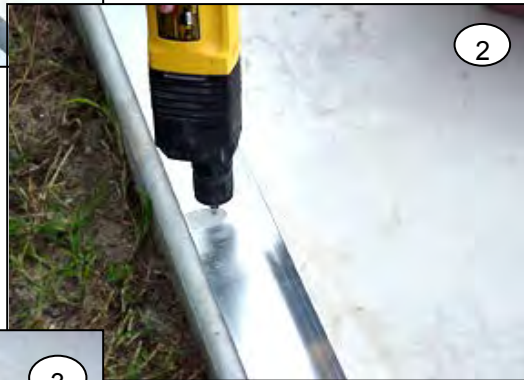

Next use a 1/4" masonry to drill the holes into the concrete footer approximately 3" deep. (**Photo 2**)



Insert the 1/4" drive pins into the holes and anchor the ABA to the concrete using a hammer as shown in **photo 3**.

Simply butt the 10' lengths end to end, until the perimeter of the greenhouse is complete.

Do not attach the ABA to the column post or leg using Tek-screws; the screw heads will interfere with the P.C.S.S. covering.



ONLY USE THIS METHOD OF SECURING "ABA" IF YOU HAVE A CONCRETE SLAB OR CONCRETE FOOTER.

INSTALLING RIDGE BASE

The ridge base extrusion will attach to the peak of the greenhouse at each center connector.

1. Identify the Ridge Base Extrusion (12'-0" in length)
2. Identify and locate 1/4" x 2 -1/2" stainless steel bolts & nuts for ridge extrusion.
3. Slide three bolts into the bolt track of the initial piece of ridge base
4. Take ridge extrusion and place the bolts into the pre-punched holes at the top of each center connector. At the end rafter, flush the ridge base extrusion with the outer face of the center connector. When flush, apply washer & lock nut. Do not tighten bolts at this point.

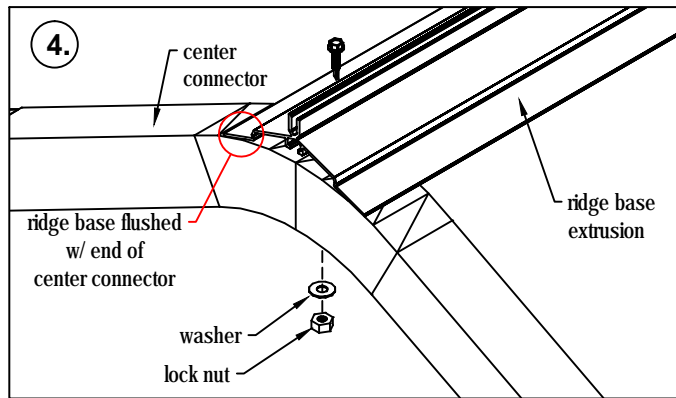
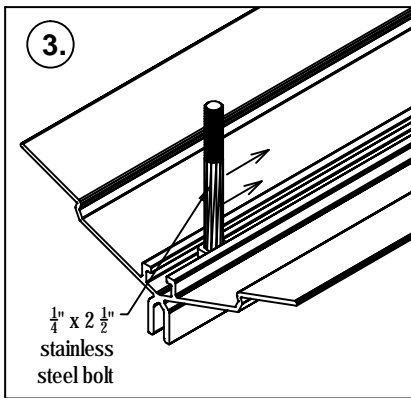
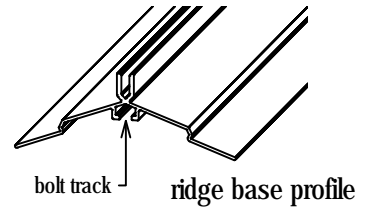
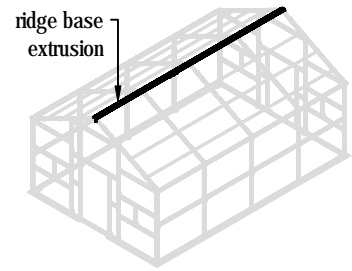

5. Connecting additional pieces of ridge base, identify Aluminum Splice Plates. Slide (2) additional 1/4" x 2-1/2" bolts into the bolt track at the end of the already installed piece of ridge base, place the splice plate onto those bolts, apply washers & lock nuts and firmly tighten splice plate to ridge base.
6. Repeat steps 4. & 5 until installation of ridge base is complete

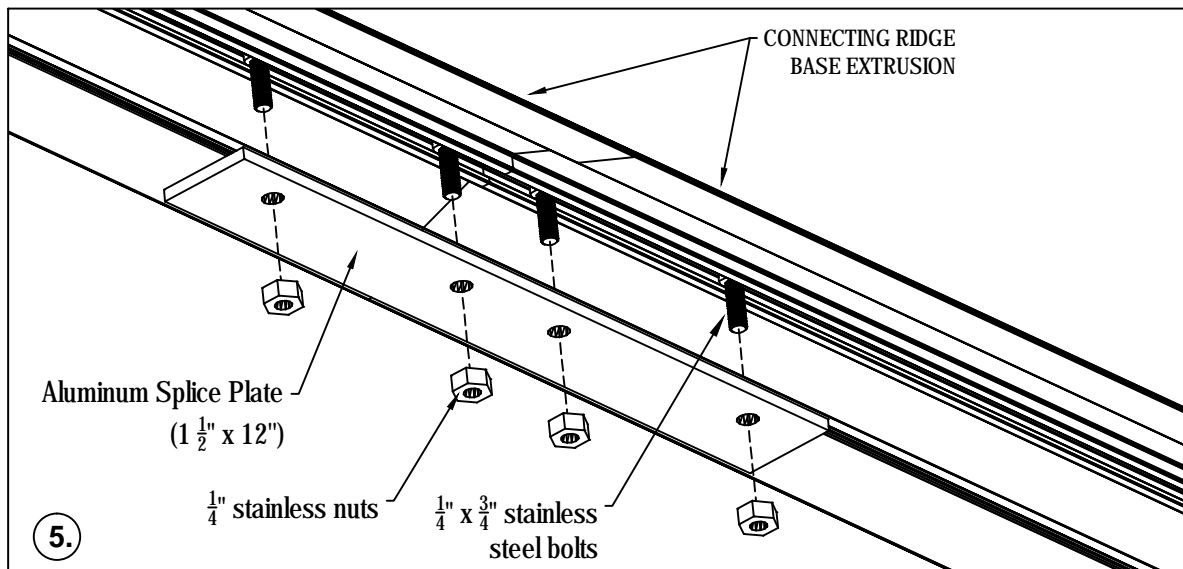

INSTALLING RIDGE CAP

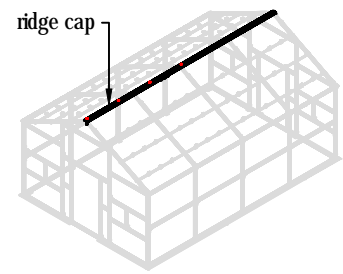

The ridge cap extrusion will attach to the ridge base extrusion forming a channel to receive and hold the polycarbonate in place at the peak of the greenhouse

1. Identify Ridge Cap Extrusion
2. Place on top and flush with the end of the ridge base.
3. Secure with one #14 x 3" tek screw approximately 2" from end, then every 4'-0" apart.

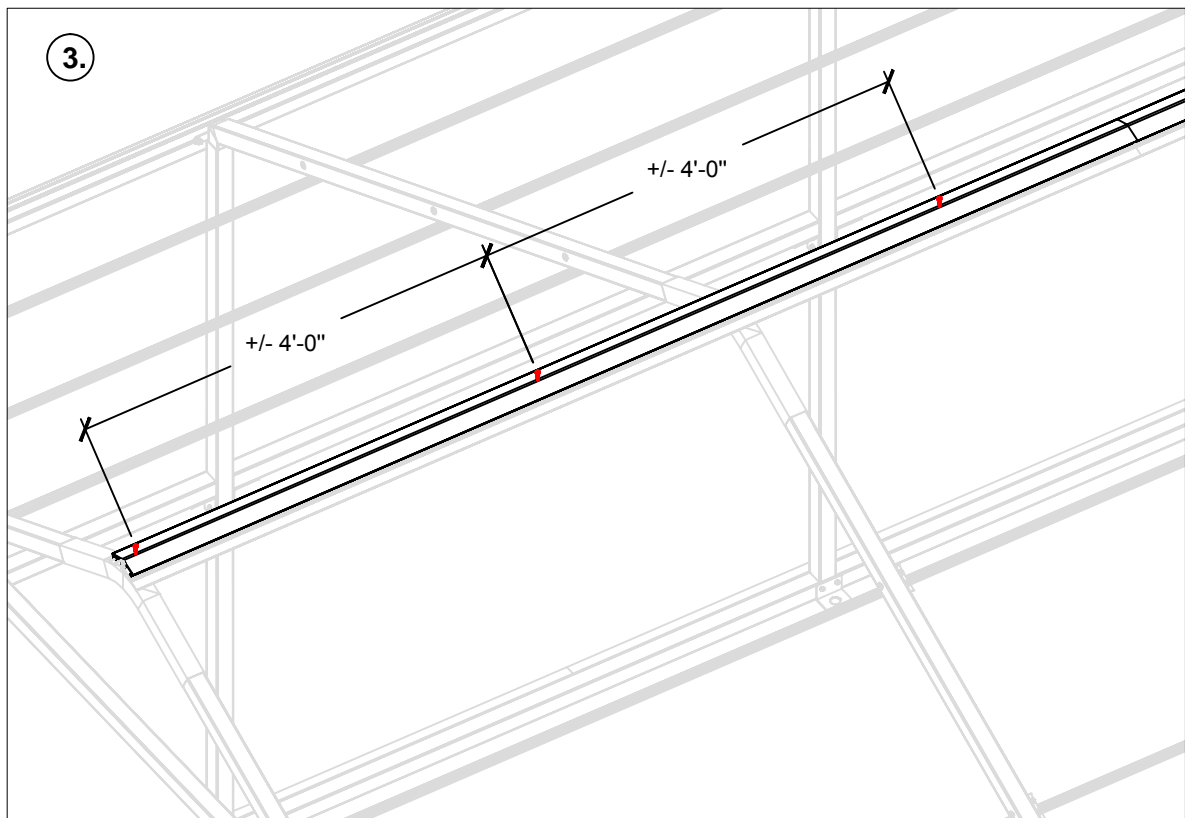
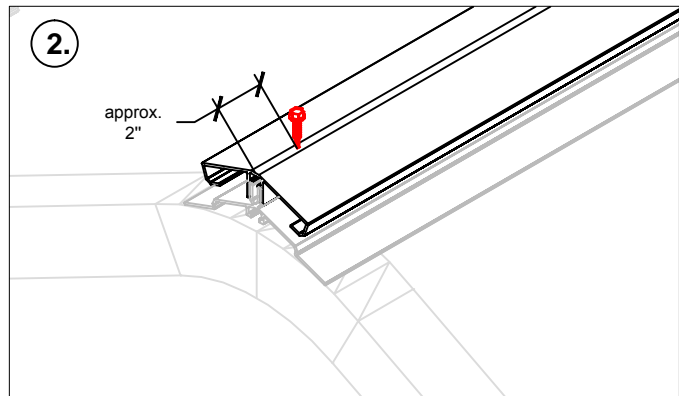
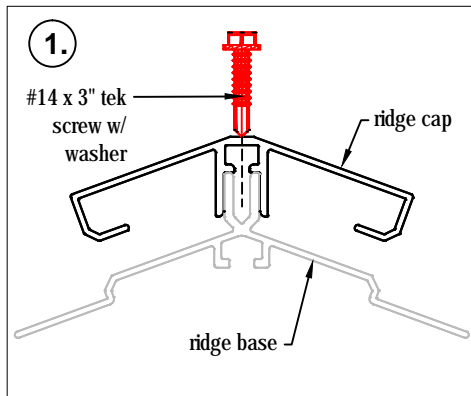

ATTACHING THE INTERMEDIATE RAFTER EXTRUSION

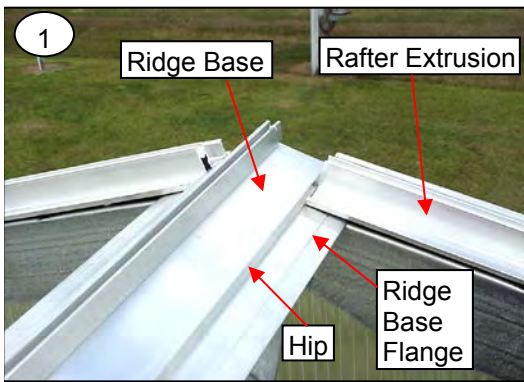

Begin by measuring from the hip of the ridge base extrusion down to the edge of the eave extrusion along the top of the rafter. Use the measurement to cut the intermediate rafter extrusion to the appropriate length. **(Ridge cap will already be attached at this point but not shown in photo #1 to help better explain how to install the intermediate rafter extrusion).**

Starting at the top, lay the Intermediate rafter extrusion over the flange of the ridge base extrusion allowing the tek-screw in the ridge base extrusion to fit inside the slot located on the underside of the intermediate rafter extrusion. **(See photo #1 & Fig. E).**

Be sure that the Intermediate rafter extrusion is pushed up against the hip of the ridge base extrusion and insert two tek-screws through the Intermediate rafter and through the flange of the ridge base extrusion. **(See photos 1 - 3 & the drawing @ the bottom of this page).**

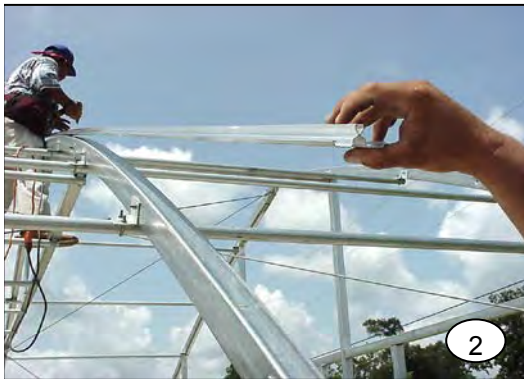

Working your way down, conform the Intermediate extrusion to the shape the rafter, while inserting two tek-screws 12 to 16 inches apart down the full length of the rafter. **(See all photos).**

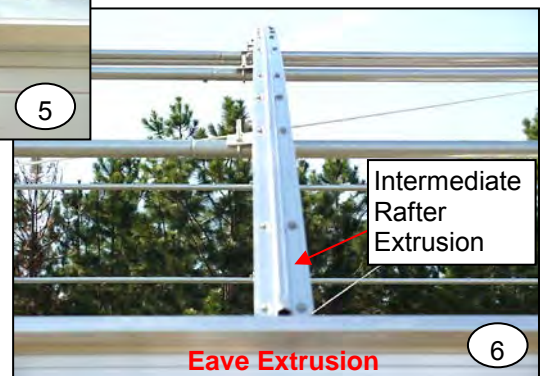
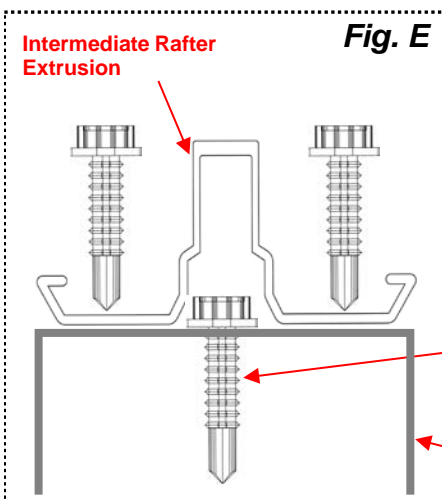
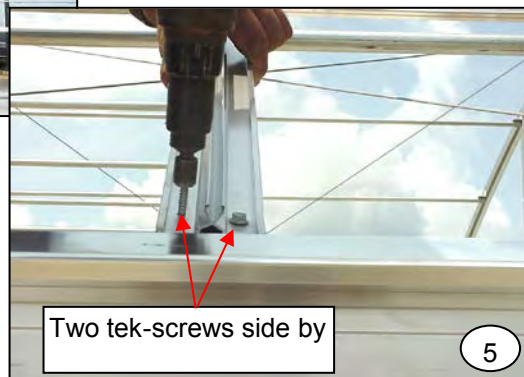

COVERING ENDS WITH P.C.S.S. USING H-SPLICE



Begin with the first sheet flush with the outside corner. Be sure the sheet is vertically level and in its proper location. Trace out any door, fan or shutter openings on the backside of the sheet and remove the excess using a skill saw. (See photos 1 & 2)

Stand the P.C.S.S. in place and attach it the end wall framing using the #12 x 1-1/2" tek-screws with the oversize washers provided. The screws will need to be spaced approximately 18" apart.

When joining two sheets together, you must attach a piece of H-splice after each sheet across the width of the house.

IMPORTANT:

Be sure to read the label on the P.C.S.S. covering to determine the side of the sheet that should face the sunlight (outside). Remove the protective film, just before attaching each sheet.

IMPORTANT:

Identify the sheets for the end walls and be sure to use them correctly. Depending on the width of your greenhouse, you should have 3 or 4 different length sheets for each end. The shorter sheets will be used at the corners and increase in length as they near the center of the house.

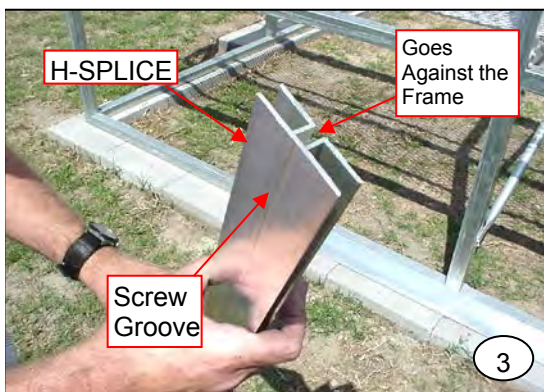

The H-splice attaches to the endwall framing using the #12 x 1-1/4" tek-screws provided. (The outside corners do not get H-splice).

Note: The small groove down the center of the H-splice, must face the outside. This is the screw groove. (See photos 3 & 4)

Allow the excess sheeting and H-splice to extend above the 2"x 3" end rafter as you complete the endwall, then remove the excess above the rafter using a sawzall or jigsaw. (See photo 5)

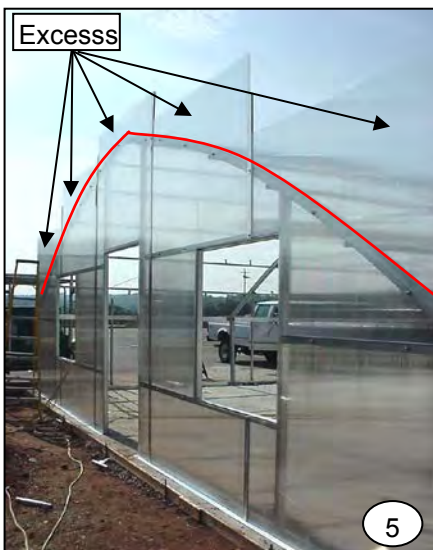
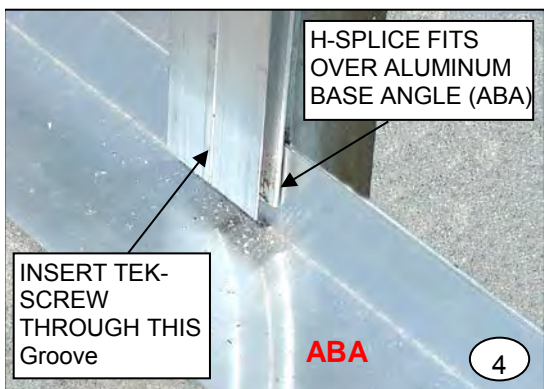

ATTACHING 1" X 1" ANGLE AROUND FAN AND SHUTTER OPENINGS

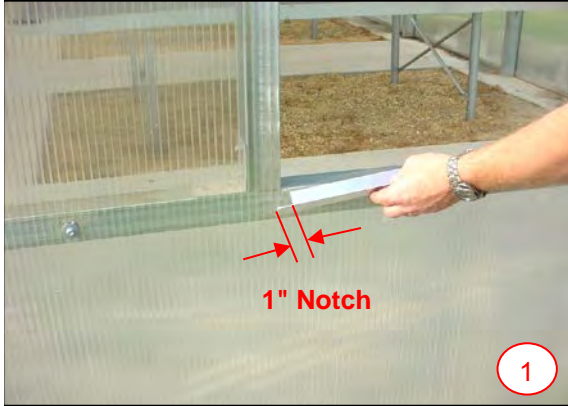

Measure the bottom of the opening and notch the 1" x 1" angle leaving 1" extending beyond the opening on both ends. (See photo 1)
 Slide the angle into the opening and attach it from the outside using the # 12 x 1" tek-screws provided as shown in photos 2 & 3.
 Repeat these steps for the top of the opening.

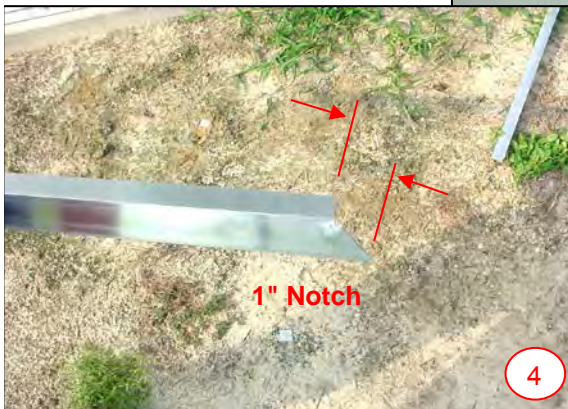

On the side of the opening measure and notch the angle on both ends as shown in photo 4.

Using this 45 degree notch will dress up the looks of the opening but is not required. If you would rather use the same notch used on the top and the bottom pieces, this is perfectly acceptable.



Slide the angle into the opening allowing it to lap over the extended portion of the top and bottom pieces and attach it from the outside using the # 12 x 1" tek-screws provided as shown in photos 5 & 6.

If the H-splice extrusion on your endwall, falls out beside the fan opening as shown in photo 7, you will not use 1" x 1" on this side.

IMPORTANT: The 1" x 1" aluminum angle is intended to be used around the fan and shutter openings only. For more Information on

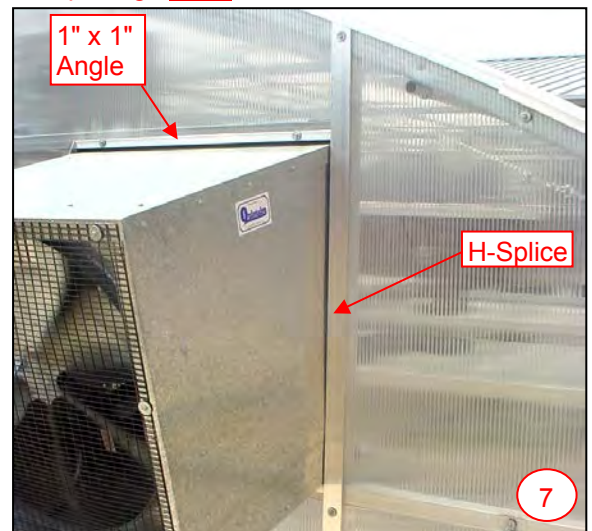

ATTACHING END RAFTER EXTRUSION



Apply foil tape to the top of the end rafter, allowing it to over-lap the top edge of the P.C.S.S. endwall covering. This prevents moisture, caused by condensation from collecting between the two layers of the P.C.S.S. covering. **(See photo #1)**

Note: Before attaching the end rafter extrusion, be sure the ends of the ridge base extrusion are covered with foil tape.

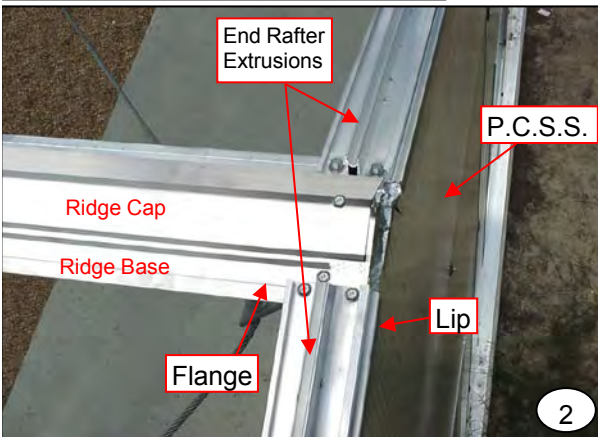

Starting at the top, lay the end rafter extrusion over the flange of the ridge base extrusion making sure that the lip is turned down lapping the P.C.S.S. endwall covering. Butt the end rafter extrusion up to ridge base extrusion and insert two screws into the end rafter extrusion, through the flange of the ridge base extrusion as shown in **photo #2. (Also see Fig. F)**

Note: The groove under the end rafter extrusion is not large enough to except the tek screw in the ridge base flange as was with the intermediate rafter extrusion.

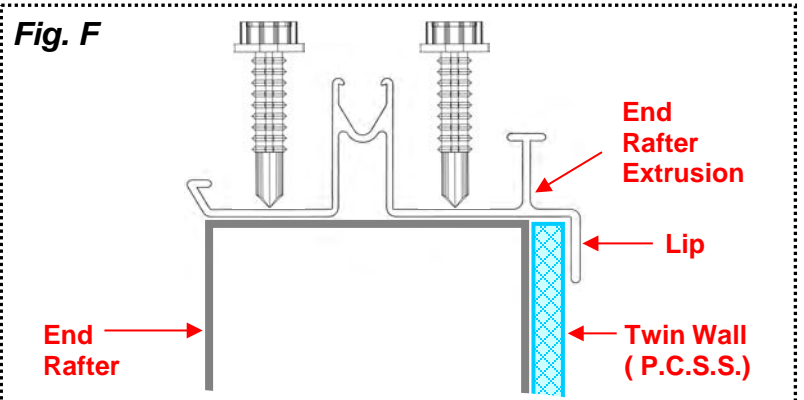

Working your way down, conform the extrusion to the shape of the rafter, while inserting two tek-screws 12 to 16 inches apart down the full length of the rafter. **(See photo #3)**

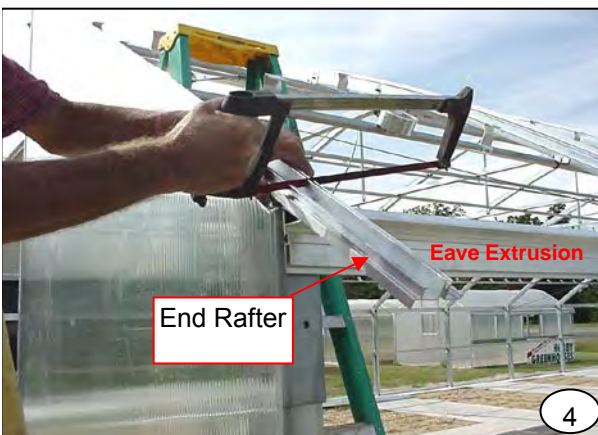

Cut off the excess, making sure that the end rafter extrusion stops flush with the edge of the eave extrusion. **(See photo #4)**

COVERING THE SIDEWALLS

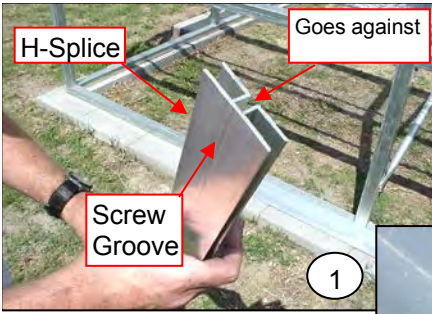

Measure and cut the H-splice to fit between the Eave Extrusion and the Aluminum Base Angle. The H-splice overlaps the top of the ABA as shown in photo #2. The H-splice attaches to columns through the screw channel using the 5/16" x 1-1/4" tek-screws approximately 15" apart. **Only attach the first H-splice. The corners Will Not get H-splice.**

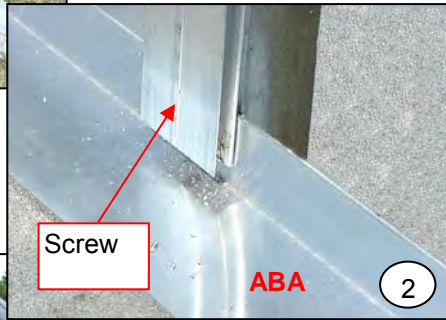

Measure from the ABA up to the top of the eave extrusion wall channel and subtract 1/4". Cut the lengths of the P.C.S.S. using a Jig-Saw or Sawzall. (Fig. G)

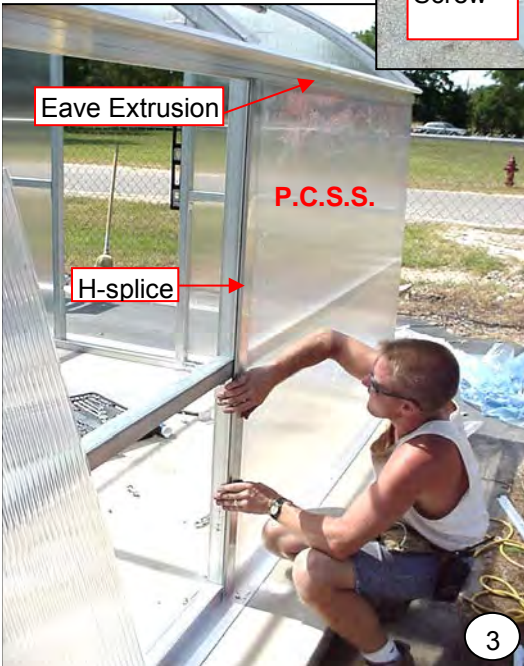
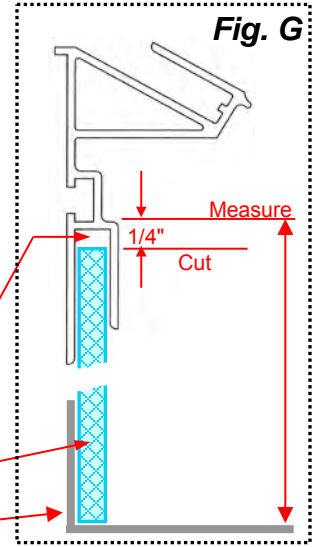

Helpful Hint:

Stack 3 to 4 sheets of P.C.S.S. on top of one another. Flush the ends of the sheets and cut all at one time to the required length. **Be careful and be sure that the measurements are correct before cutting.** **Consider wearing eye and ear protection while cutting.**

With the first piece of H-splice in place, insert the first sheet of P.C.S.S. upward into the eave extrusion channel and slide the sheet sideways until it is completely seated into the H-splice Channel. (See photo 3)

Note: The P.C.S.S. may have up to 3/16" of slack in the H-splice or the eave extrusion channel. This is O.K.

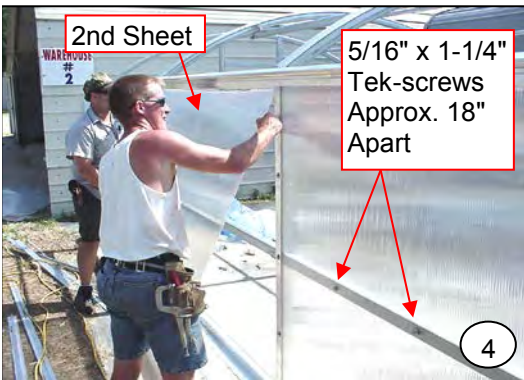

Peel off the protective film and attach the P.C.S.S. sheeting to the ABA and the sidewall horizontal purlin using the 5/16" x 1-1/4" tek-screws approximately 18" apart. Be sure that the correct side of the sheet is facing outward.

Repeat the procedure for the second sheet by inserting the sheet upward into the eave extrusion first then sliding the sheet over into the H-splice channel. Now slide the H-splice on the opposite end of the sheet and attach it to the column post using the 5/16" x 1-1/4" tek-screws. Attach the P.C.S.S. to the ABA and the sidewall horizontal purlin using the 5/16" x 1-1/4" tek-screws also. (See photos 4 & 5)

Continue this procedure until you reach the end. Repeat the procedure for the opposite side of the house.

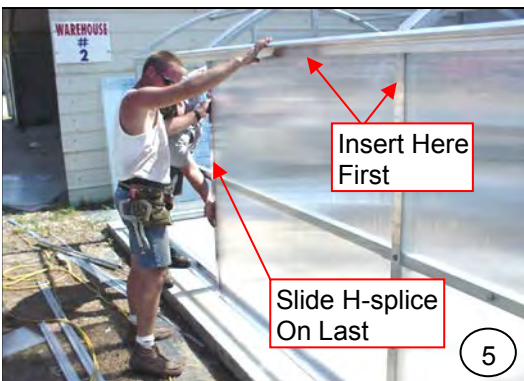

ATTACHING 1" X 1" ANGLE AROUND BASE

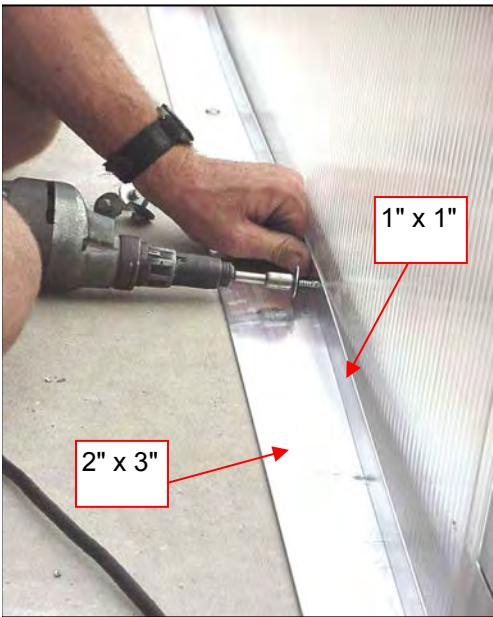

Identify and attach the 1"x 1" aluminum angle. This 1" aluminum angle lies over the 2" x 3" Aluminum Base Angle (ABA) and against the P.C.S.S. at the base of the structure.

Attach using 5/16" x 1-1/4" tek-screws approximately 24" apart.

Lap each section of 1" x 1" approximately 2" to 3" as you continue around the perimeter of the structure.

Use the same process for notching the corners as you did with the 2" x 3" ABA.

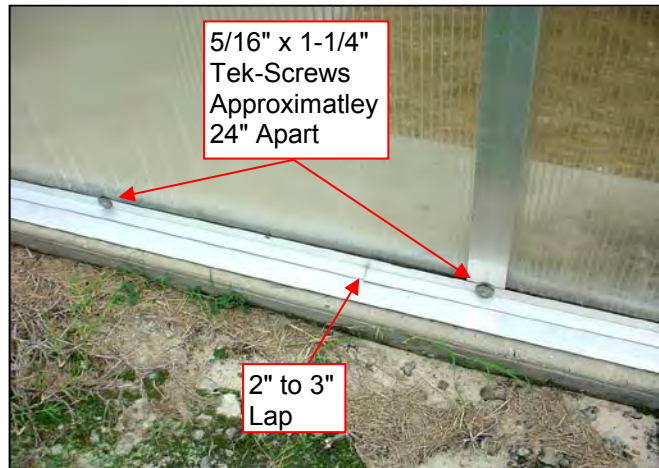

ATTACHING THE CORNER FLASHING



Applying the corner flashing

Identify the 2" x 3" aluminum flashing (the same as the base angle we used earlier)

Using tin snips or a jig saw, cut the corner flashing to length and trim the top end to fit as neat as possible.

Attach the corner trim using Tek-Screws with washers.



INSTALLING P.C.S.S. ROOF COVERING

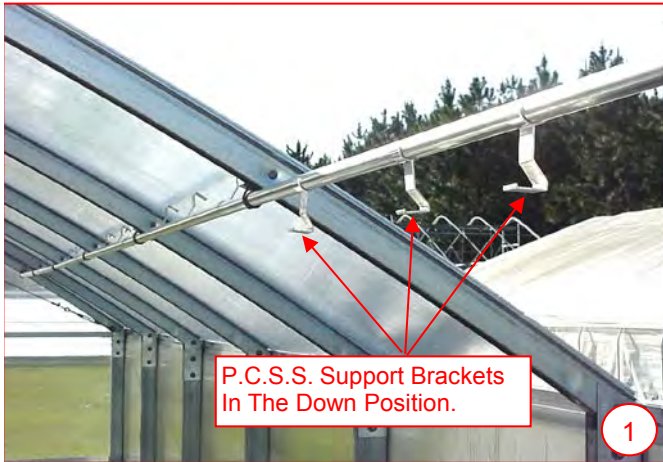

After all extrusions are in place, snap the P.C.S.S. support brackets onto the purlins. Each purlin will receive (3) support brackets between each rafter as shown in **photos 1 & 3**. Let the P.C.S.S. support brackets hang upside down and out of the way until you get the P.C.S.S. roof panels in place. (See **photo 1**)

IMPORTANT:

Remember to check the label and place the proper side of the P.C.S.S. toward the sun.

Slide the first sheet of P.C.S.S. onto the roof and between the ridge base and the ridge cap extrusions. The P.C.S.S. sheets will be a few inches too long. Be sure that the sheet is pushed all the way up before cutting. (See **Fig. H**)



While holding the P.C.S.S. in place, make a mark 1/2" up from the bottom of the eave extrusion roof channel. (See **Fig. I**) This is the only way to be sure the P.C.S.S. will be the proper length.

It is not necessary to place the sheet on a saw horse. Slide the sheet downward a few inches and cut using a skill-saw or jig-saw. Now slide the sheet back up between the ridge base and ridge cap, slightly buckle the sheet upward and allow the sheet to fall into the eave extrusion channel.

USE EXTREME CAUTION WHEN CUTTING THE P.C.S.S.

After each roof panel is in place, flip the P.C.S.S. support brackets up and insert a #12 x 1-1/2" washer tek-screw through the P.C.S.S. covering and into each of the support brackets. Be careful, over tightening the screws will damage the covering. There should be (3) support brackets between each rafter. (See **photo 3 & 4**)

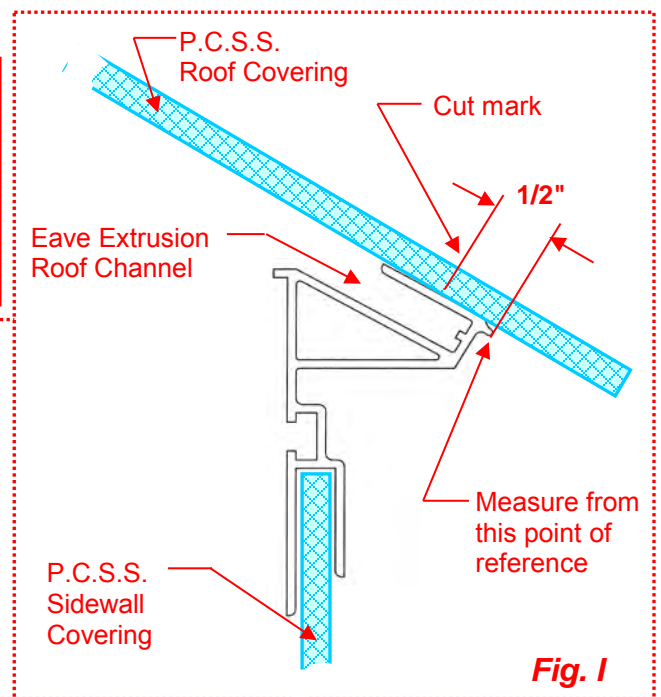
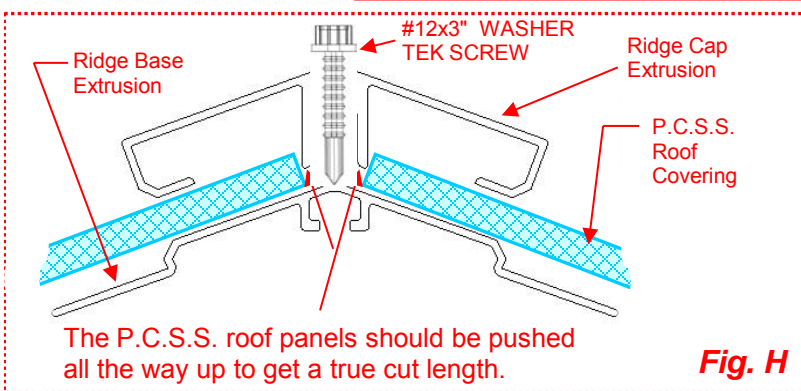
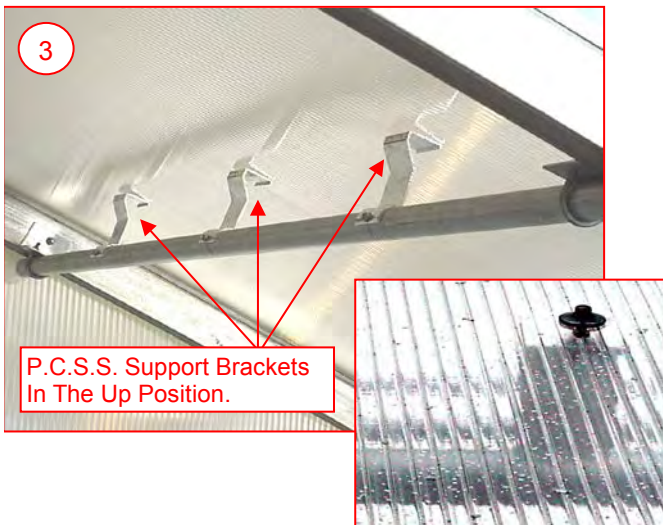

INSTALLING P.C.S.S. ROOF COVERING (CONT'D)



1

At the end rafter and on the intermediate extrusions between each roof panel, you will need to attach a piece of aluminum cap. Lay the cap in place and Screw into place using #12x2" washer teks on all end rafters and #12x1" washer teks on intermediate rafters approx. 36" apart

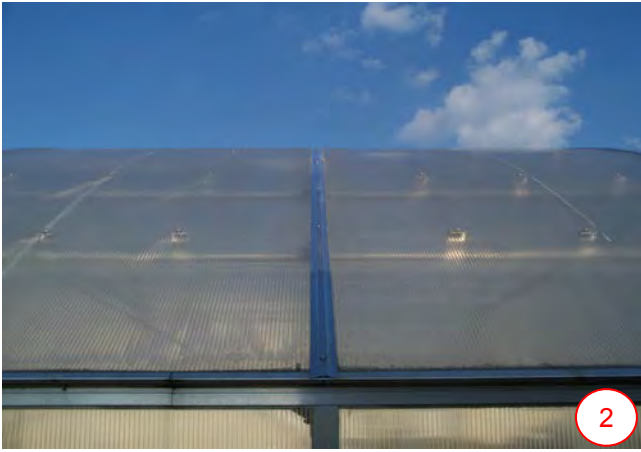

2

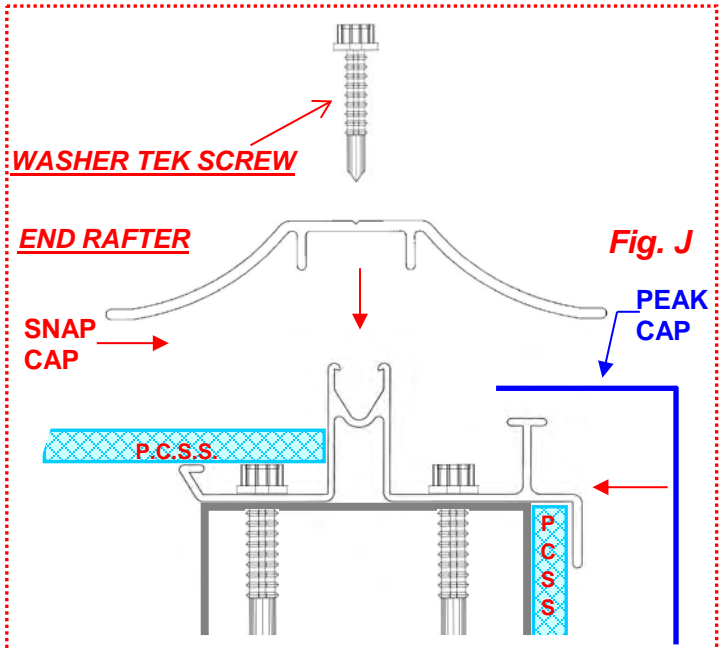

3

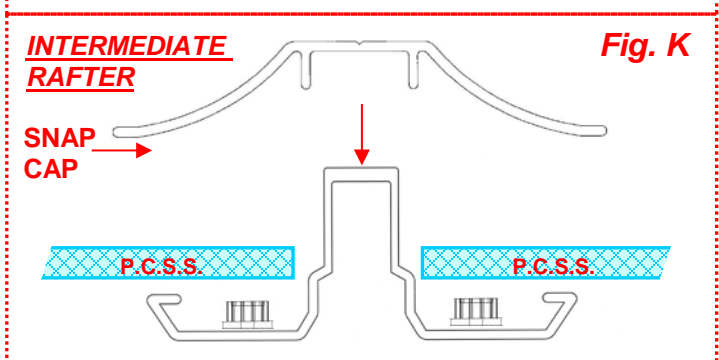

If the Aluminum cap extends beyond the edge of the house, remove the excess by cutting it flush with the outside edge of the eave extrusion using a hack-saw. (See photo 3)

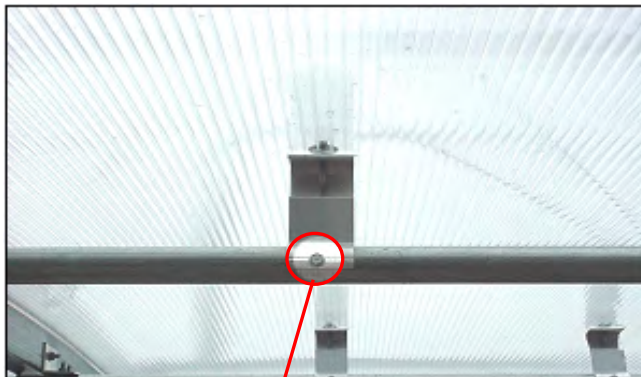

VERY IMPORTANT:
Once all the P.C.S.S. roof panels have been installed, you must insert a tek-screw through each of the P.C.S.S. support brackets into the purlins. Failure to do so, could result in structure failure in severe weather conditions.



Finish off the end walls by capping each gable end peak, using a peak cap. Allow the 1-1/2" flange of the peak cap to slide between the end rafter extrusion and the snap cap until the peak cap is lying flush against the end wall. Center the peak cap and insert two #12 x 2" washer tek-screws through the aluminum cap, the peak cap and into the end rafter extrusion. (See the above photo & Fig. J)

HAF FAN INSTALLATION



USE THE CHAINS PROVIDED TO ATTACH HAF FANS DIRECTLY TO THE BOW ASSRMBLY OR TRUSS CHORD. USING TEK SCREWS, SCREW THE CHAINS DIRECTLY TO THE SIDE OF THE BOW ASSEMBLY AS ILLUSTRATED IN PHOTOS 1 & 2.



THE HANGING BRACKETS CAN ALSO BE USED TO ATTACH THE HAF FANS TO A TRUSS CHORD WHETHER IT BE SQUARE, RECTANGLE, OR ROUND TUBING AS SHOWN IN PHOTO 3.

PREVENTATIVE MEASURES

After you have completed the greenhouse, use clear caulking to seal any places water might leak

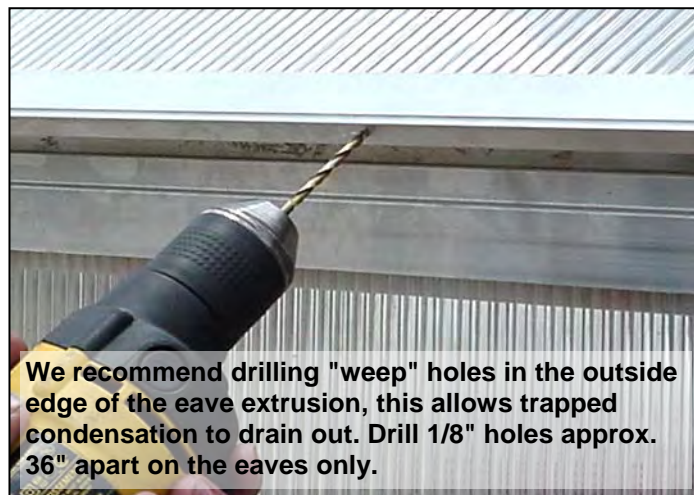
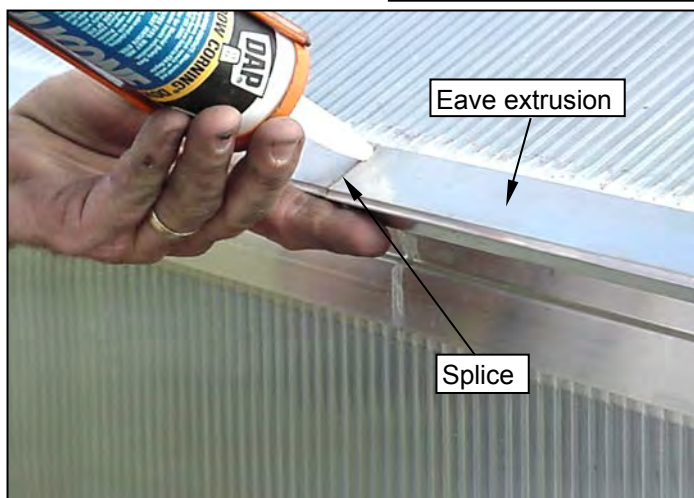

Final Note:

If the greenhouse is not put into operation immediately and you do not have the fans, shutters, and cooling system operating, we highly recommend that you prop open all shutters, doors and vents. This will help prevent the greenhouse from overheating and causing the thermostats to lose their calibration. ***(Thermostats will lose calibration if temperatures exceed 120 degrees F).***

FAILURE TO PROPERLY VENTILATE THE GREENHOUSE, WILL RESULT IN THERMOSTAT DAMAGE. THIS IS NOT COVERED BY THE MANUFACTURER'S WARRANTY!!!

12' wide Scholar

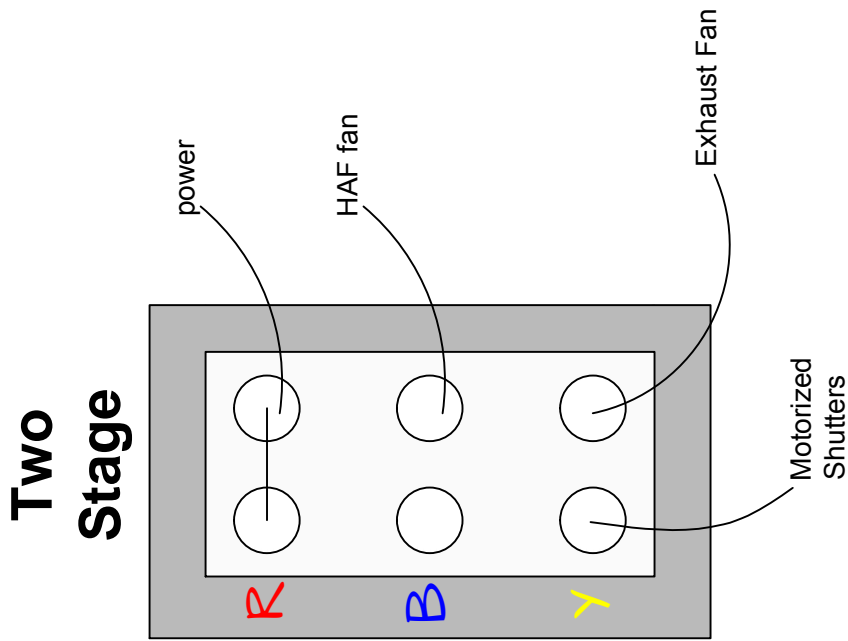

IMPORTANT: When wiring a heater the power must be run to heater first, not the thermostat